

# MODEL 50 SERIES TRACTORS



JOHN DEERE

## OPERATORS MANUAL MODEL 50 SERIES TRACTORS

OMR2033 F7 English

**OMR2033 F7**

LITHO IN THE U.S.A.  
ENGLISH

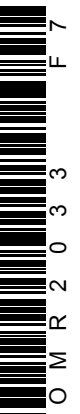

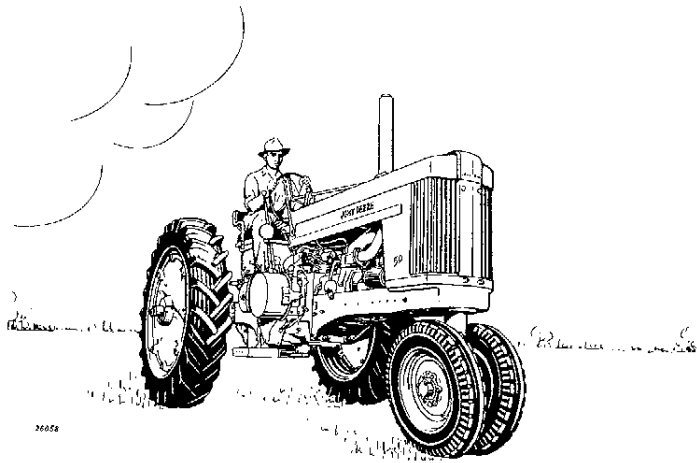

## TO THE PURCHASER

We welcome you to our ever-growing family of John Deere tractor owners. We are confident that the dependable and economical performance of the John Deere Model "50" Tractor will prove that you made a wise choice.

The purpose of this manual is to acquaint you with your new tractor. The manual explains how to operate and service your tractor, and how to maintain its high operating efficiency. Instructions are given clearly with the intention of making these operations as easy as possible.

Keep this manual in a convenient place for quick and easy reference. Use it as a guide whenever questions arise. You have purchased a dependable, sturdy tractor, but only by operating and caring for it properly can you expect to receive the service and long life for which it was designed.

If in the future you need new parts to replace those that may be worn, insist on genuine John Deere parts. They are exact duplicates of the originals, made from the same patterns and of the same high-quality materials.

When in need of parts, give your John Deere dealer the serial number of your tractor, distributor, or Powr-Trol, depending on the parts you need. The illustration below shows you where to find these serial numbers. Obtain them from your tractor—NOW—and insert them in the spaces provided in the illustrations below.

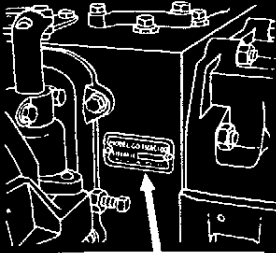
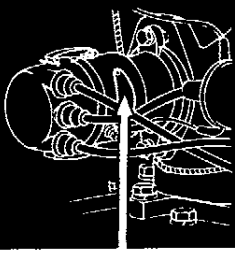
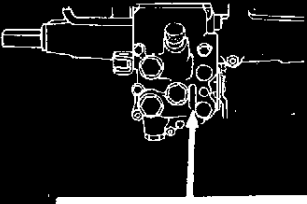
TRACTOR	DISTRIBUTOR	POWR-TROL
		
Owner <input type="text"/>		
162 Date Purchased <input type="text"/>		

**• TABLE OF CONTENTS •**

	<i>Page</i>
SPECIFICATIONS AND DATA.....	5
CONTROLS AND INSTRUMENTS.....	7
OPERATING INSTRUCTIONS.....	21
SAFETY SUGGESTIONS.....	56
LUBRICATION AND PERIODIC SERVICES.....	59
SERVICE THAT WILL KEEP YOUR TRACTOR IN TIP-TOP SHAPE.....	79
SERVICE REMINDERS.....	108
TRACTOR DIFFICULTIES.....	109
STORING THE TRACTOR.....	115
INDEX.....	116

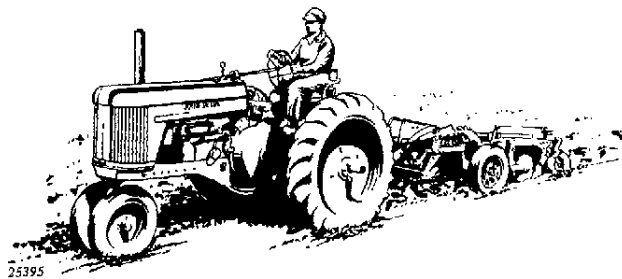

**<https://www.ebooklibonline.com>**

Hello dear friend!

Thank you very much for reading.

Enter the link into your browser.

The full manual is available for immediate download.

**<https://www.ebooklibonline.com>**

Even though your dealer has carefully inspected this tractor before delivering it to you, it is always good business to re-check the items which are encircled on the reproduction below of the envelope which contains this manual.

## TO THE NEW JOHN DEERE TRACTOR OWNER

Each John Deere Tractor is carefully designed, assembled, and given a complete test and final inspection at the factory before it is shipped. Our main ambition is to deliver tractors to new owners in the same mechanical condition as when shipped from the factory.

To enable us to fulfill this one ambition, this tractor was carefully inspected for irregularities that may have occurred in shipment. This inspection included a complete checking of the following:

- Wheel equipment. Tire pressure Wheel weights. Install calcium chloride if requested by new owner.
- Radiator. Fill with water or anti-freeze.
- Air cleaner. Oil level.
- Manifold heat control.
- Crankcase. Oil level.
- Transmission oil level.
- Steering housing oil level.
- Powr-Trol oil level.
- Power shaft clutch oil level.
- Grease tractor.
- Rear wheel brakes.
- Clutch operation.
- Spark plug gaps.
- Tighten cap screws and nuts.

- Carburetor setting (May require adjusting later according to fuel burned). (See Instructions in Manual.)
- Engine speed and oil pressure.
- Inspect rubber hose connections.
- Connect battery ground terminal. Check battery water level. Grease terminal posts.
- Check lights.
- Check starting motor for operation.
- Serial numbers entered in owner's register.

The above inspection made by *John Doe*

Date *3/2/58* Dealer *Good Business Supply Co.*

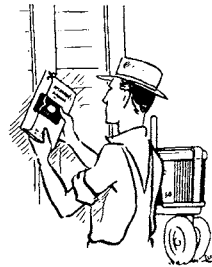

HANG THIS BOOK IN A  
HANDY PLACE

We suggest this rechecking especially during freezing weather or when a period of time has elapsed between delivery and when you are ready to operate it. For complete starting information, see page 24.

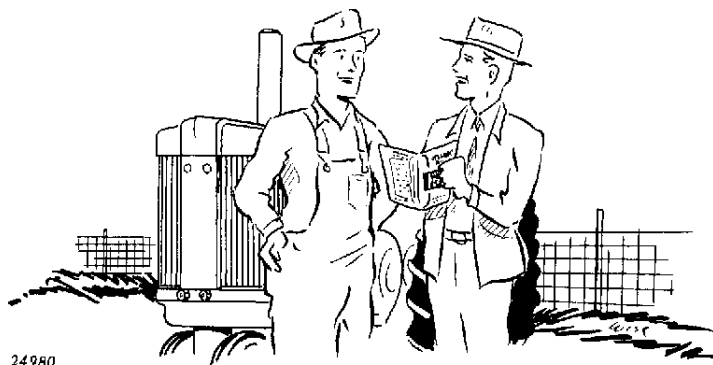

We, your John Deere dealer, are mighty proud to add your name to our list of John Deere tractor owners. Because we are interested in having you obtain from this new tractor all the comfort and long life that are built into it, we are pleased to discuss the following important maintenance operations:

- Controls.
- Manifold Heat Control.
- Breaking-in Period—Part Load, Open Throttle, Changing Oil.
- Method of Starting and Stopping Engine.
- Lubrication—Engine, Transmission, Power Shaft Clutch, Powr-Trol, Grease Fittings, Air Cleaner and Oil Gauge.
- Cooling System—Adding Water, Thermostat, Cleaning.
- Fuel System—Fuel, Fuel Control, Sediment Bowl and Trap, Carburetor Adjustment.
- Tires—Inflation, Inspection, Wheel Weights.
- Drawbar—Adjustment; pull from no other place.
- Battery Registration.
- Ignition System—Terminals Tight, Cleaning, Oiling, Adjusting Points.
- Rear Wheel Brakes—Adjustment.
- Clutch—Adjustment, Pulley Brake.
- Front Wheels—Cleaning, Adjustment and Spacing.
- Powr-Trol—Drop Control, Operation.
- Power Shaft Clutch Adjustment and Operation.
- Starter and Lights—Starting, Lights, Battery Care,
- Tightening Cap Screws and Nuts.
- Safety in Operation—Selecting Proper Speed, Power Shaft.
- Keeping the Tractor Clean.
- Have Farmer Operate the Tractor.
- Appointment for After-Sales Service—not later than two weeks after delivery.

4

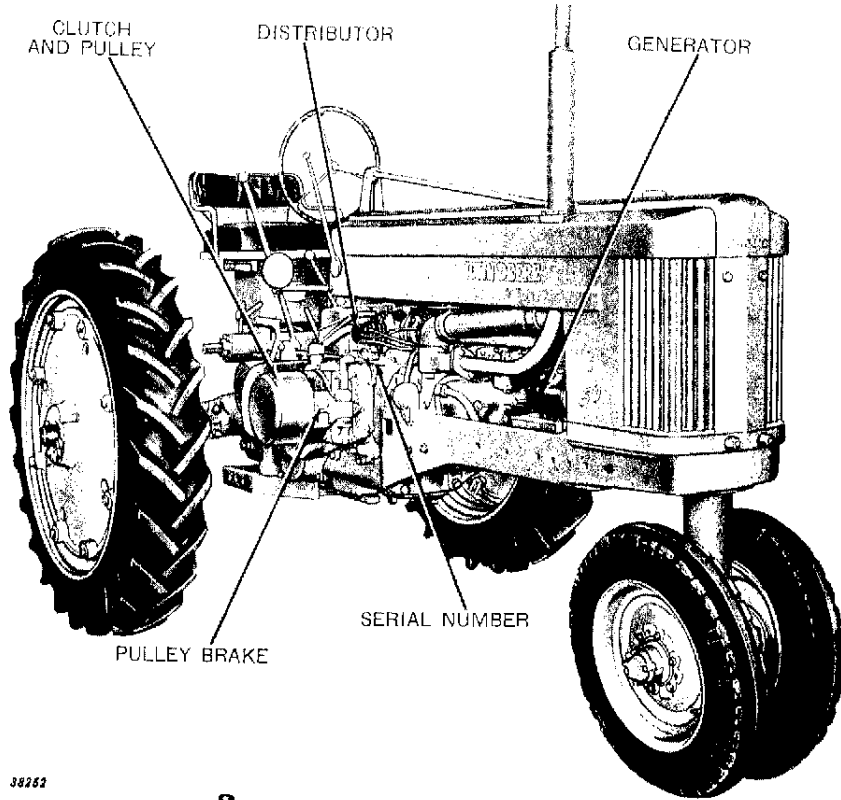

38282

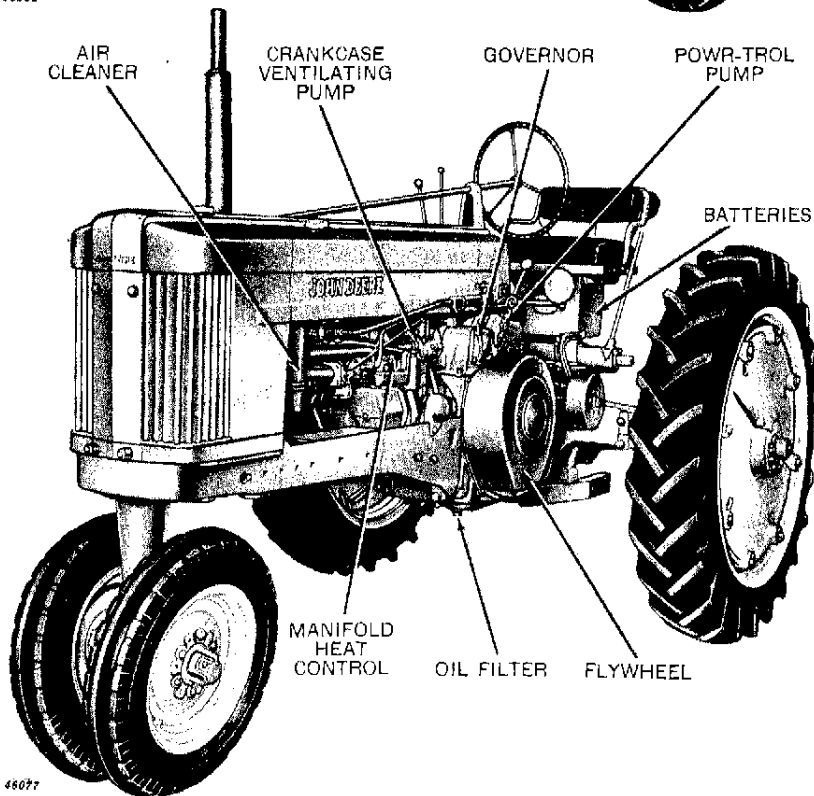

46677

# SPECIFICATIONS AND DATA . . .

## PERFORMANCE:

Two 14-inch plow bottoms under most conditions. Three 14-inch plow bottoms under many conditions is a common practice.

### Maximum Belt Horsepower:

*Gasoline.....	30.97
*All-Fuel.....	25.75

### Maximum Drawbar Horsepower:

*Gasoline.....	27.49
*All-Fuel.....	23.22

## CAPACITIES (U. S. MEASUREMENTS):

Gasoline Tank:	
Gasoline Tractor.....	15-1/2 Gals.
All-Fuel Tractor.....	2 Gals.
Fuel Tank (All-Fuel)....	15-1/2 Gals.
Crankcase.....	7 Qts.
Transmission.....	4 Gals.
Power-Trol.....	6 Qts.
Power Shaft Clutch....	2-1/4 Qts.
Remote Cylinder.....	1 Qt.
Cooling System.....	4-3/4 Gals.
First Reduction Gear Cover.....	1 Qt.

## SPEEDS:

Gear	10-38 Tires	9-42 Tires
1	1-1/2 mph	1-3/4 mph
2	2-1/2 mph	2-3/4 mph
3	3-1/2 mph	3-3/4 pmh
4	4-1/2 mph	4-3/4 mph
5	5-3/4 mph	6 mph
6	10 mph	10-3/4 mph
Reverse	2-1/2 mph	2-3/4 mph

## ENGINE:

Type.....Two-cylinder, cast-in-block, valves-in-head.

### Engine Speeds:

Load.....	1250 rpm
Idle.....	1375 rpm

Bore and Stroke... 4-11/16" x 5-1/2"

Displacement..... 190.4 cubic inches

### Compression Ratio:

Gasoline.....	6.25 to 1
All-Fuel.....	5.35 to 1

## LUBRICATION SYSTEM

Type..... Full force-feed pressure system with full flow oil filter.

## FUEL SYSTEM:

Type.....	Gravity feed.
Carburetor.....	Natural-draft duplex type.
Air Cleaner.....	Oil-wash type.

## COOLING SYSTEM:

Type.....	Pressure system—centrifugal pump with engine temperature controlled by heavy-duty automotive-type thermostat.
-----------	---

## IGNITION SYSTEM:

Type.....	Battery-Distributor
Distributor Point Gap (Delco-Remy).....	.022"
Spark Plugs:	
Size.....	18 mm.
Spark Plug Gap.....	.030"

## ELECTRICAL SYSTEM:

Battery Voltage.....	12 Volts
Generator Regulation....	Voltage Regulator.
Battery.....	Group I

## CLUTCH:

Type.....	Hand-operated, four 7-inch dry disks.
-----------	---------------------------------------

## BELT PULLEY:

Diameter.....	9-11/16"
Width.....	7-1/4"
Rpm (Load).....	1250
Belt Speed.....	3170 fpm

## TRANSMISSION:

Type.....	Six speeds forward and one in reverse.
Gears.....	Selective-type, straight spur-cut gears, forged and heat-treated.
Bearings....	Shafts operate on three roller bearings, four tapered roller bearings, and five ball bearings.

(Continued on next page)

\*Maximum h.p. corrected to 60°F. and 29.92 in. hg. (Nebraska Tests Nos. 486 and 507).

**REAR AXLES:**

Diameter..... Regular.... 2-7/8"  
 Long..... 3-1/8"  
 Bearings..... Four tapered roller  
 bearings.  
 Types Available... Regular and long

**REAR WHEELS AND TIRES:**

Regular Rear Axle.. 10-38, 4-ply tires  
 on cast disk  
 wheels (recom-  
 mended for aver-  
 age field condi-  
 tions). 11-38, 4- or  
 6-ply tires also  
 available.  
 Long Rear Axle.... 9-42, 6-ply tires  
 on cast disk  
 wheels. 11-42, 6-  
 ply, 10-38, 4-ply  
 and 11-38, 4- or 6-  
 ply tires also  
 available.

**REAR WHEEL BRAKES:**

Type..... Two automotive-type  
 internal-expanding rear  
 wheel brakes.

**FRONT WHEELS AND TIRES:**

Double and Adjustable Type:  
 Reversible for added clearance.  
 Bearings..... Four tapered roller  
 bearings.  
 Tires..... 5.50 x 16", 4-ply.  
 Single Type:  
 Bearings..... Two tapered roller  
 bearings.  
 Tires..... 6.50 x 16", 4- or 6-ply.  
 9.00 x 10", 8-ply.

	Double Front Wheel* (38" Rear Wheel)	Single Front Wheel (42" Rear Wheel)	Adjustable Tread Front Axle (42" Rear Wheel)
<b>POWER TAKE-OFF:</b>			
Shaft Diameter.....	1-3/8"	1-3/8"	1-3/8"
Shaft rpm:			
Transmission Driven.....	541	541	541
Direct Engine Driven.....	532	532	532
Splined End Ahead of Hitch.....	14"	14"	14"
Splined Shaft Above Ground:			
Transmission Driven.....	21-1/16"	22-3/4"	22-3/4"
Direct Engine Driven.....	22-5/8"	24-5/16"	24-5/16"
<b>DIMENSIONS:</b>			
Wheel-Base.....	90"	90-1/4"	96-3/8"
Over-All Height.....	82-3/16"	82-3/4"	83-3/4"
Height to Radiator Cap.....	59-7/8"	60-7/16"	61-7/16"
Width Over Axles.....	86-5/8"	95-15/16"	95-15/16"
Tread Adjustments.....	56-88" **	56-104"	56-104"
Clearance.....	24-1/4"	26"	Front 24" Rear 26"
Turning Radius.....	8' 7-1/2"	10' 5"	17' 0"
<b>SHIPPING WEIGHT</b> .....	4435 lbs.	4465 lbs.	4875 lbs.
(Weights are for Tractor dry and with wheel equipment as shown under "Front Wheels" and "Rear Wheels")			

\*Available with double front wheel, single front wheel, or adjustable tread front axle.

\*\*Available with long axles providing tread of 62-1/2" to 97-3/4" and with offset wheels a tread of 56" to 10 1/4".

(In the interest of progress, we reserve the right to change design without notice)

## CONTROLS

**T**HE quality of work and the amount of work you do with your tractor not only depend upon the use of proper equipment, but also upon the ease and convenience of tractor operation. If you are in an uncomfortable position, if you have to fight the steering wheel, or if you can't see what you are doing, you are definitely handicapped.

Your John Deere Tractor is as convenient to handle as your automobile. All controls and levers are reached easily from the operator's seat. Under your feet are the convenient brakes and a large, comfortable platform on which you can stand if you so desire.

Familiarize yourself with all the controls provided for safe and easy operation of your new tractor. Regardless of your previous tractor experience, study this section covering controls carefully before you operate your tractor.

## STARTING CONTROLS

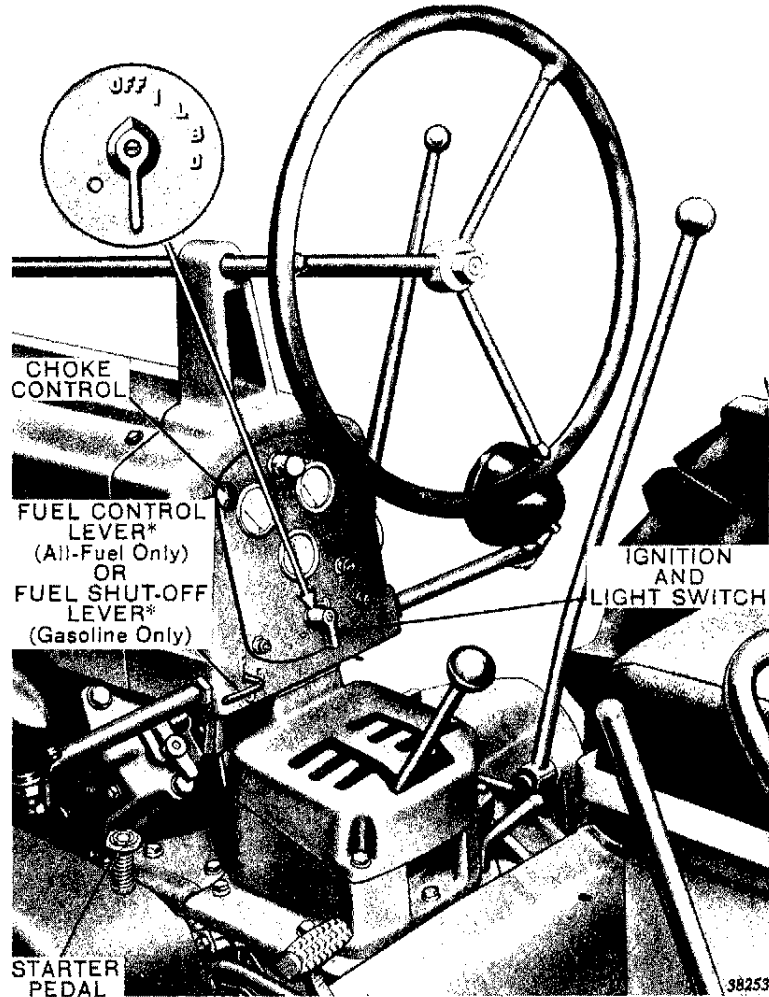

*Starting Controls*

*\*Gasoline tractors with automatic fuel shut-off do not have this lever.*

### IGNITION-LIGHT SWITCH.

The ignition on your new tractor is controlled by a combination ignition-light switch located in the center of the instrument panel. Turning the switch to any position except "OFF" turns on the ignition.

Your tractor is equipped with lights which are designed to provide maximum use and convenience both for night work in the field and night travel on the highway. The combination rear lamp has a bright white light for illuminating drawn implements and a red light for highway travel.

All lights are controlled by the combination ignition-light switch. The switch has five positions as follows:

- “OFF”—Both ignition and lights off
- “I” —Ignition only
- “L” —Bright front lights and white rear light
- “B” —Bright front lights and red rear light
- “D” —Dim front lights and red rear light

### FUEL SHUT-OFF (GASOLINE TRACTORS).

Some gasoline tractors are equipped with a hand-operated shut-off lever which enables the operator to shut off fuel at the filter bowl. To close the fuel shut-off valve, turn lever in a clockwise direction.

Other gasoline tractors are equipped with an automatic oil-pressure-operated fuel shut-off valve located on top of the fuel filter bowl. When the engine is stopped, the valve automatically shuts off flow of fuel to the filter. As soon as the engine is turned over by the starter the valve is automatically opened by engine oil pressure.

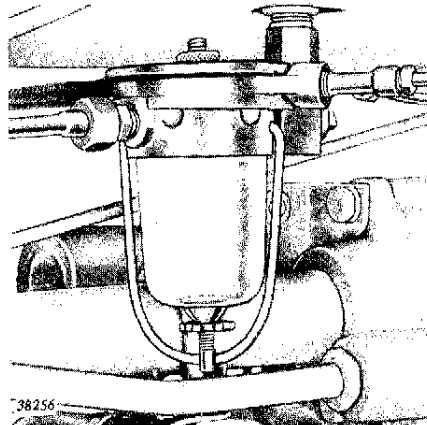

*Fuel Filter with Automatic Shut-Off Valve*

### FUEL-CONTROL LEVER (ALL-FUEL TRACTORS).

A three-way fuel control lever on All-Fuel tractors enables the operator to switch from gasoline for starting the engine to low-cost fuel for operation, or to shut off the fuel supply entirely without leaving his position at the wheel.

### STARTER PEDAL.

The engine is started by the pedal located in convenient reach of the operator's left foot. The pedal engages the starter pinion with the fly-wheel and also completes the electrical circuit to the starting motor. For starting instructions see page 27.

### CHOKE CONTROL.

Pulling the choke button provides a rich mixture for the engine when starting. When button is pushed in, the choke returns to its normal position.

**OPERATING CONTROLS**

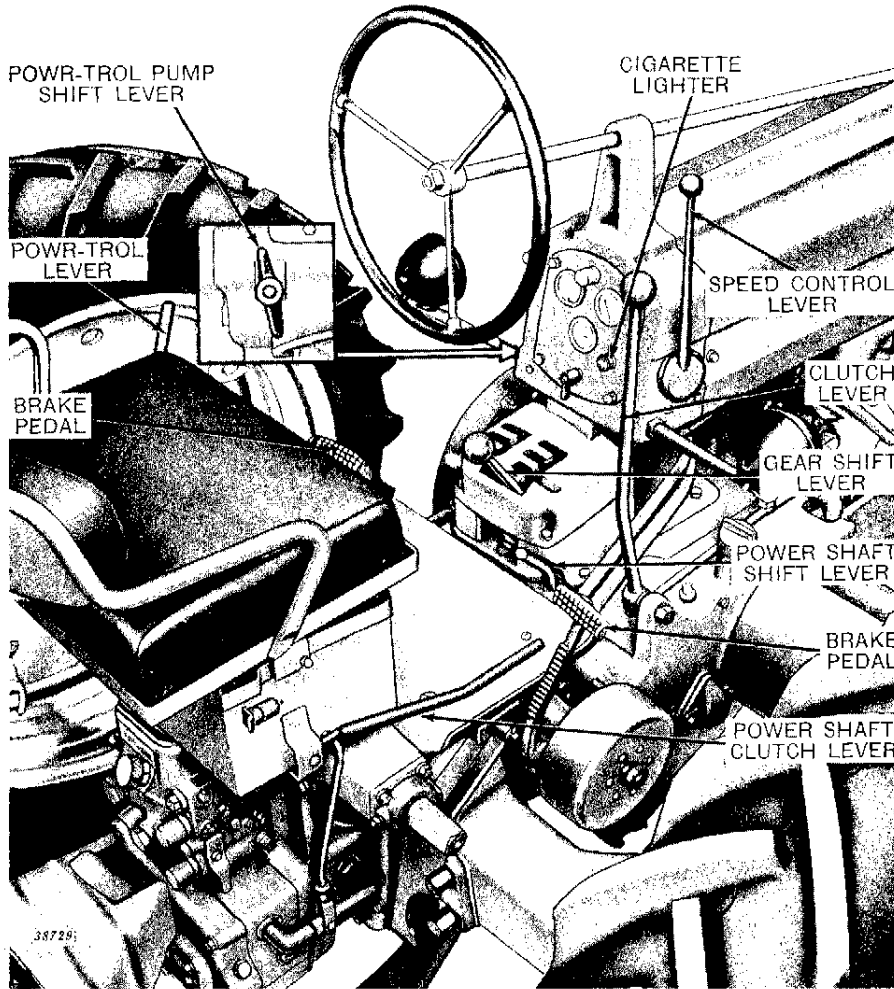

*Operating Controls*

### SPEED CONTROL LEVER.

The lever mounted on the right-hand side of the hood support regulates the speed of the tractor engine. Pushing it forward opens the throttle and pulling it back closes the throttle. *NOTE: It is good practice to operate the engine whenever possible with speed control lever in forward position.*

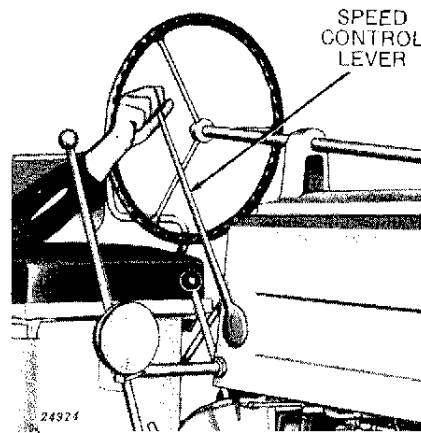

*Speed Control Lever*

### CLUTCH LEVER AND PULLEY BRAKE.

Power required to put the tractor in motion is gradually and smoothly applied to the drive system by slowly pushing the clutch lever forward. When the tractor picks up speed, a quick forward thrust on the lever snaps the clutch into engagement.

By pulling back on the clutch lever, the clutch is released and engine disconnected from the transmission.

The pulley brake, which is applied when the clutch lever is pulled back to disengage the clutch, stops the pulley from rotating, permitting easy shifting of the transmission gears. *NOTE: Do not use pulley brake to stop tractor.*

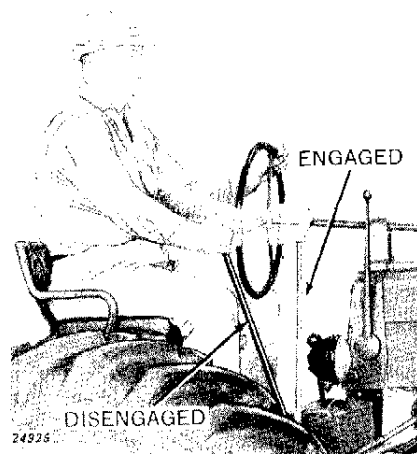

*Clutch Lever and Pulley Brake*

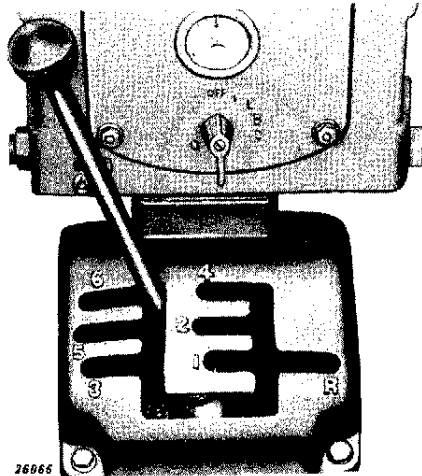

*Gear Shift Lever Positions*

#### GEAR SHIFT LEVER.

The gear shift lever is located directly in front of the operator, within easy reach. It is used to select the proper gear ratio for most economical operation depending upon the load and speed.

Familiarize yourself with the shifting before attempting to operate the tractor.

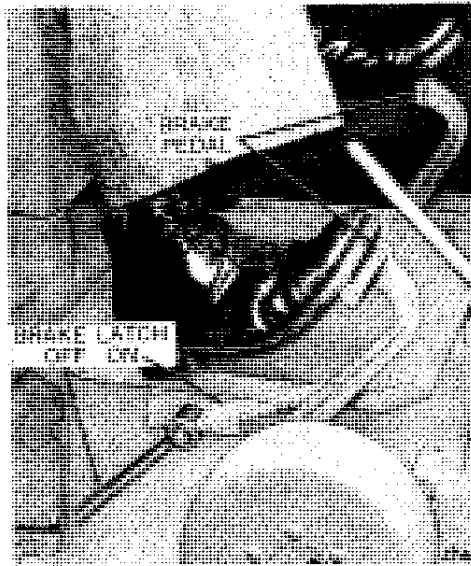

*Brake Pedals and Latches*

#### BRAKES.

Individually foot-operated brakes make possible short turns to right or left.

To assure safe stopping at high transport speeds, apply the brakes evenly to avoid drawing the tractor to one side.

A brake latch is conveniently located for locking each brake when doing belt work or when holding the tractor on a hill or incline.



**Suggest:**

**If the above button click is invalid.**

**Please download this document**

**first, and then click the above link**

**to download the complete manual.**

**Thank you so much for reading**

### SEAT AND BATTERY COMPARTMENT.

The large, roomy seat adds much to operator comfort and materially lessens fatigue.

A stop pin and adjusting lever, located on the right-hand side of the seat, make it possible to move the seat forward and backward to suit the convenience of the operator.

The back of the seat can be adjusted for height by removing the attaching screws shown in the illustration and raising or lowering the back to suit the operator.

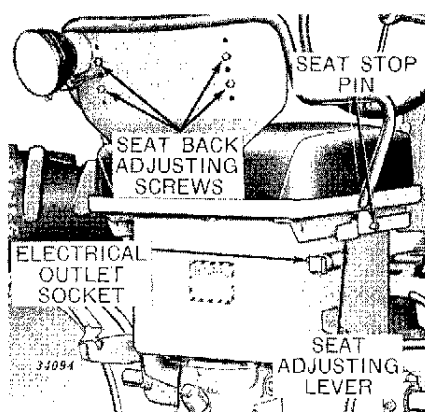

*Seat*

The batteries are located in a compartment under the seat where they are readily accessible for periodic checking and service.

An electrical outlet socket is located on the right-hand side of the battery box. This socket is provided for you to attach your battery charger, trouble light, or lights on your trailing implements.

### STEERING MECHANISM.

The seat location and streamlined hood design permit easy view of work on either side or at the rear. This design, coupled with a steering mechanism built to eliminate objectionable wandering, backlash, or whipping of the steering wheel permits you to work in freedom and comfort.

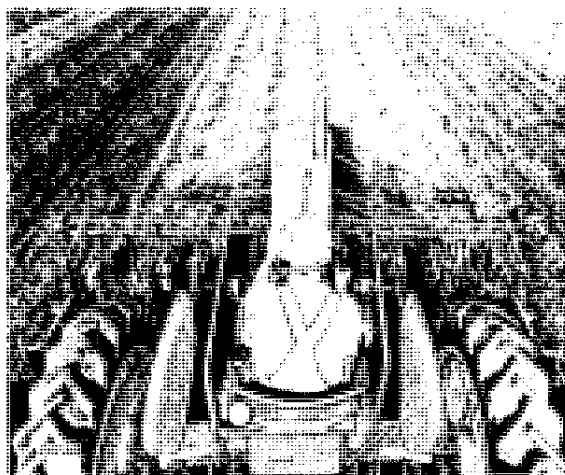

*Steering a Model "50" Tractor*

If your tractor is equipped with exclusive John Deere Power Steering you will be able to steer without effort in the roughest going. Even such adverse conditions as deep sand or heavy front-end-mounted equipment will not affect the ease with which you turn the steering wheel.

**<https://www.ebooklibonline.com>**

Hello dear friend!

Thank you very much for reading.

Enter the link into your browser.

The full manual is available for immediate download.

**<https://www.ebooklibonline.com>**