

Material Collection System (MCS) for ZTRAK Front Mowers

Serial No. (010001-)



OPERATOR'S MANUAL

**John Deere
Worldwide Commercial And
Consumer Equipment Division
OMM133287 G8**

North American Version
Litho in U.S.A.
English

TABLE OF CONTENTS

Safety Signs.....	1
Installing	4
Removing.....	9
Operating Machine	13
Replacement Parts	22
Service Machine Safely	23
Service	24
Troubleshooting	30
Storing Machine	31
Assembly	32
Specifications	58
Index.....	65
John Deere Service Literature	69

All information, illustrations and specifications in this manual are based on the latest information at the time of publication. The right is reserved to make changes at any time without notice.

COPYRIGHT© 1998
Deere & Co.
John Deere Worldwide Commercial and
Consumer Equipment Division
Horicon, WI
All rights reserved

OMM133287 G8

<https://www.ebooklibonline.com>

Hello dear friend!

Thank you very much for reading.

Enter the link into your browser.

The full manual is available for immediate download.

<https://www.ebooklibonline.com>

SAFETY SIGNS

Safety-Alert Symbol

Read and recognize safety information. Be alert to the potential for personal injury when you see this safety-alert symbol.

On your machine safety labels, the words DANGER, WARNING, and CAUTION are used with this safety-alert symbol. DANGER identifies the most serious hazards. In this manual, the word CAUTION and this symbol call attention to safety messages.

Keep safety signs in good condition. You can buy safety signs from your John Deere dealer.



Machine Safety Labels

Caution—Avoid Injury When Dumping MCS Box

To avoid injury when dumping box, shut off blower and mower. Do Not dump box without safety retention spring properly installed. Catcher assembly is subject to wear and deterioration, check frequently and replace when necessary.

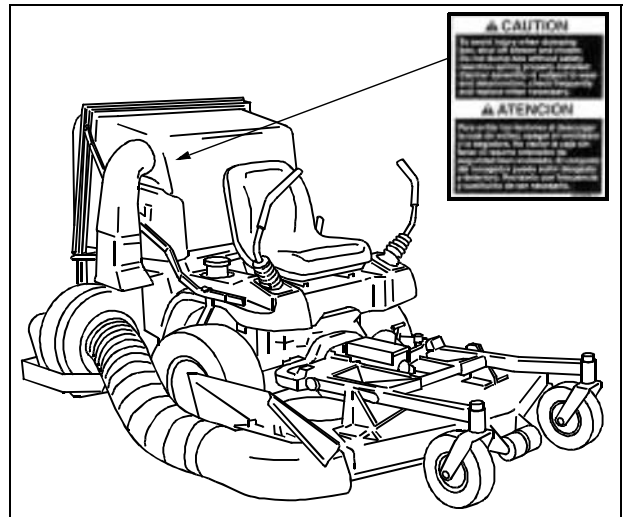

Warning—Avoid Injury From Crushing

To avoid injury from crushing, keep hands and fingers away from this area.

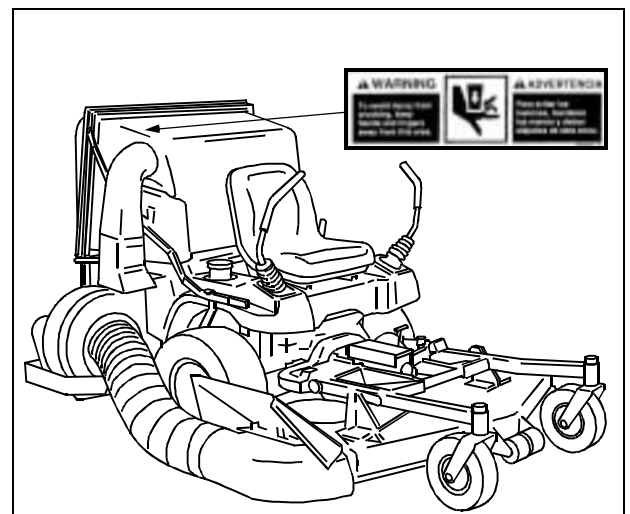

SAFETY SIGNS

Warning—Avoid Injury From Fan Blades and Thrown Objects

Avoid injury from fan blades and thrown objects. Remove material collection systems impeller housing, hose and boot when operating vehicle in side discharge mode.

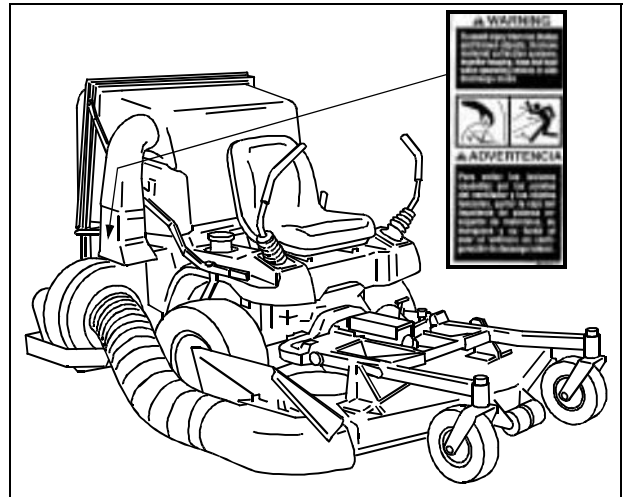

Caution—Avoid Injury From MCS Handle

To avoid injury, lock handle in position before operating blower or mower.

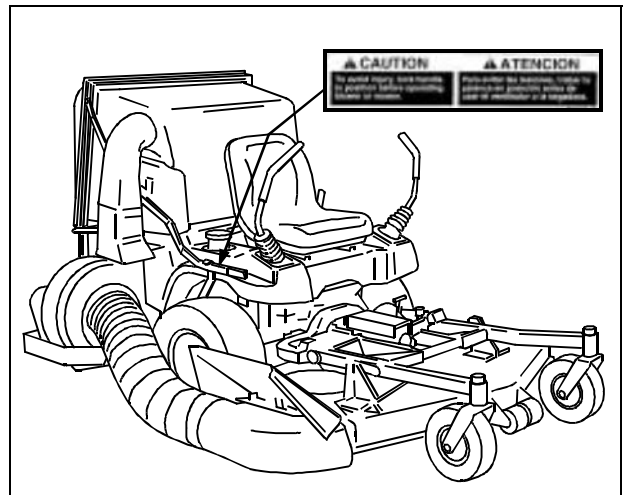

Warning—Avoid Injury From Rotating Belts

To avoid injury from rotating belts, keep all shields and guard in place.

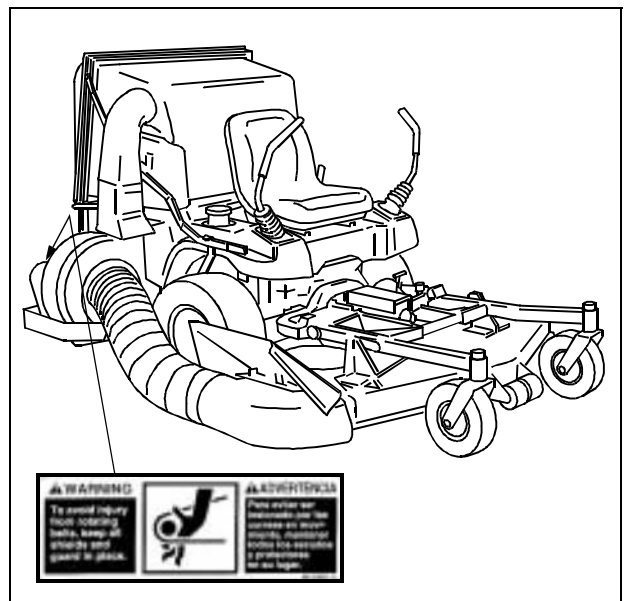

SAFETY SIGNS

Warning–Avoid Injury From Fan Blades

To avoid injury from fan blades, Do Not operate blower without chute and hose secured in place.

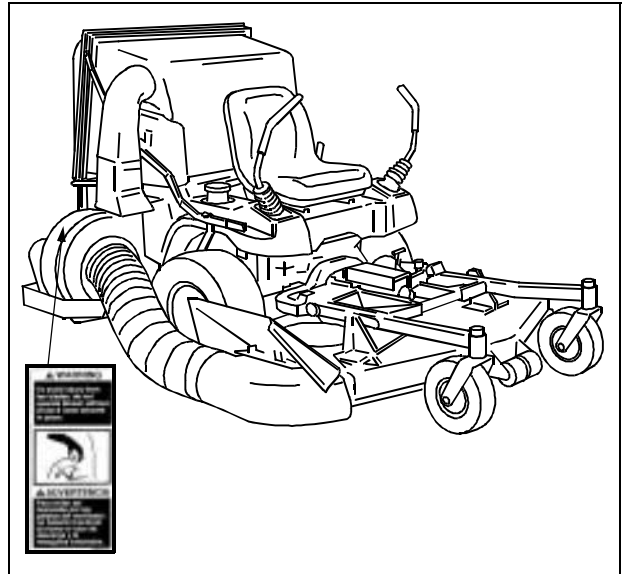

Warning–Avoid Injury From Thrown Objects

To avoid injury from thrown objects, Do Not operate without hoses securely in place.

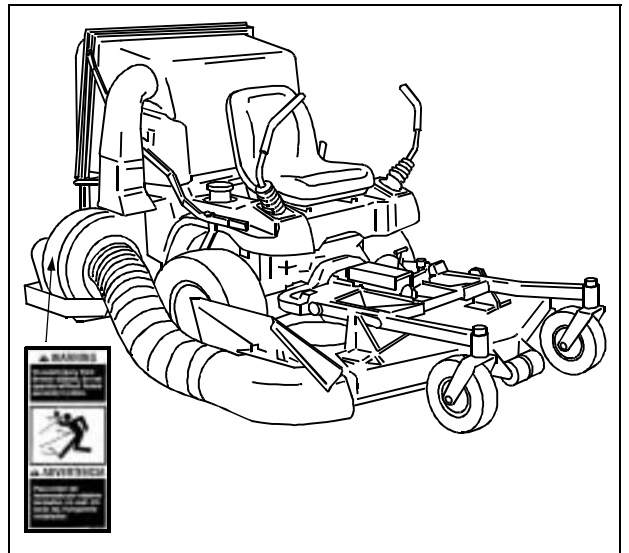

Warning–Avoid Injury From Thrown Objects

To avoid injury from thrown objects, Do Not operate mower without chutes and hoses securely in place.

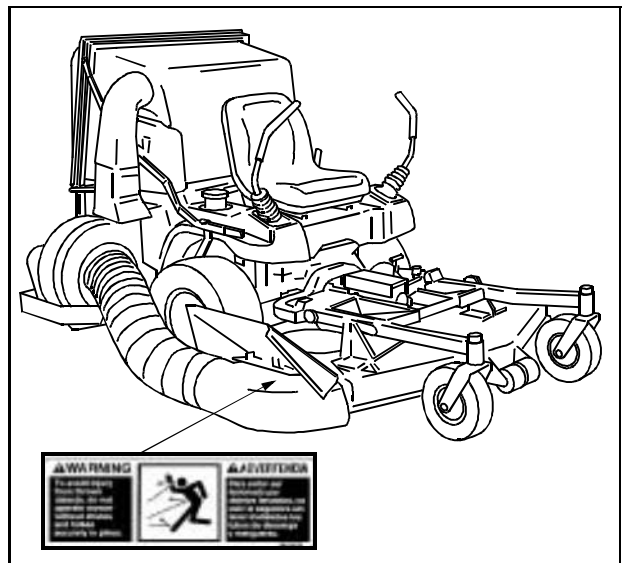

INSTALLING

Park Vehicle Safely

- Stop vehicle on a level surface, not on a slope.
- Disengage PTO.
- Engage the park brake.
- STOP the engine.
- Remove the key
- Before you leave the operator's seat, wait for engine and all moving parts to STOP.

Installing the MCS

1. Park Front Mower on a hard level surface.
2. Stop engine and engage park brake.
3. Remove clevis pins from stored position in the rear frame assembly.
4. Install collection box and frame assembly onto each protruding hex bolt shaft as shown.
 - Insert clevis pin (A) from the top on each side of the rear frame assembly.

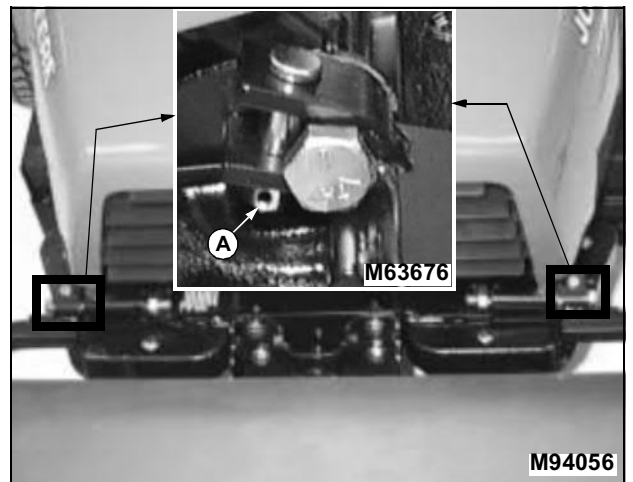

5. Raise and secure Front Mower cowling (B) in the open position. (See **Raising and Lowering Cowling** in the Front Mower operator's manual **Operating Machine** section.)



INSTALLING

6. Install lower dump linkage strap (C).

- Secure strap in position on blower mounting bracket stud (D) with washer (E) and locking ring (F).

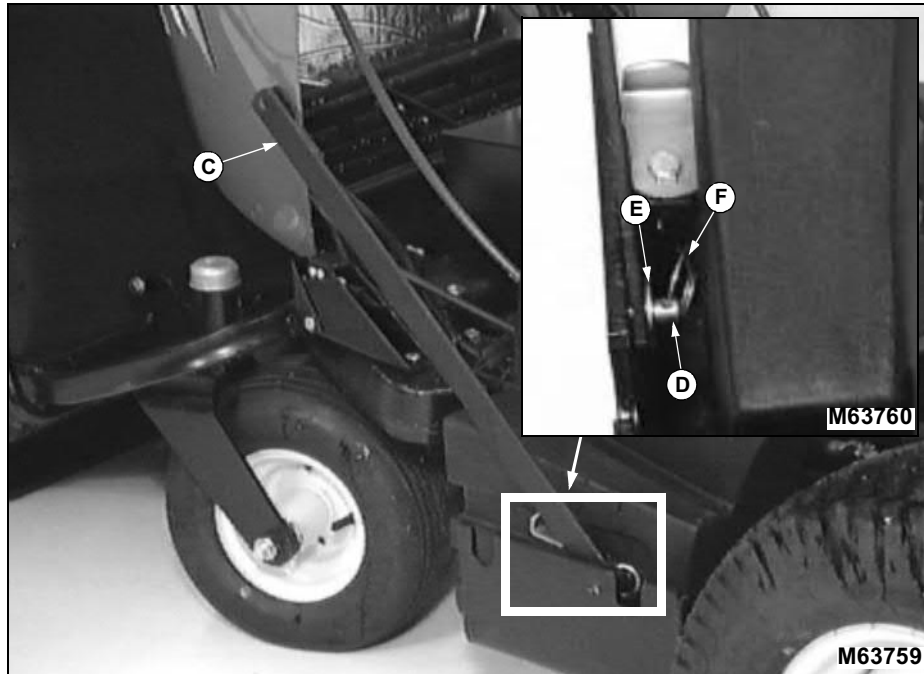

7. Install blower onto the Front Mower mounting bracket.

- Round mounting hardware (G) at the bottom of the blower assembly should be inserted into blower support bracket slots.
- Rotate locking clip (H) in position to secure blower to the blower mounting bracket.

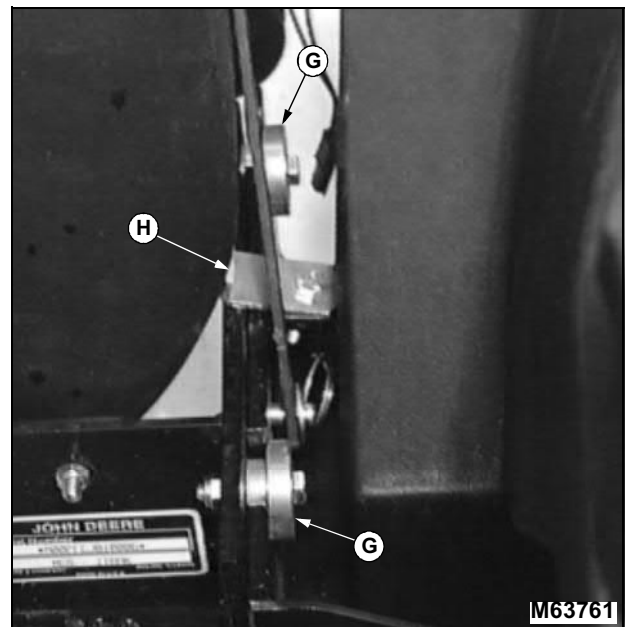

INSTALLING

⚠ CAUTION: Help prevent serious bodily injury due to entanglement in a belt or pulley. **DO NOT** start the Front Mower engine when performing this assembly procedure.

NOTE: Remove blower belt shield and hardware attached to the blower housing.

8. Install blower drive belt.

- Install drive belt onto Front Mower rear PTO drive sheave (I).
- Install drive belt (J) onto blower sheaves, idler and electric clutch pulleys.

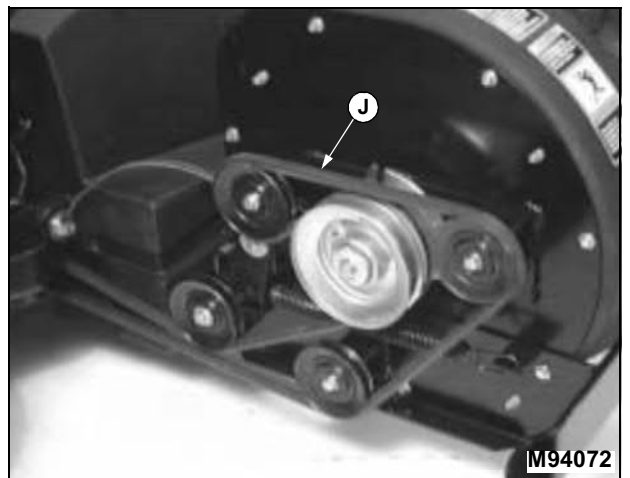
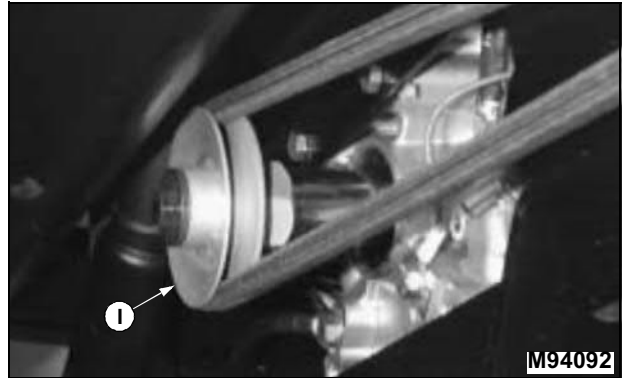

- If necessary see label inside of belt shield.

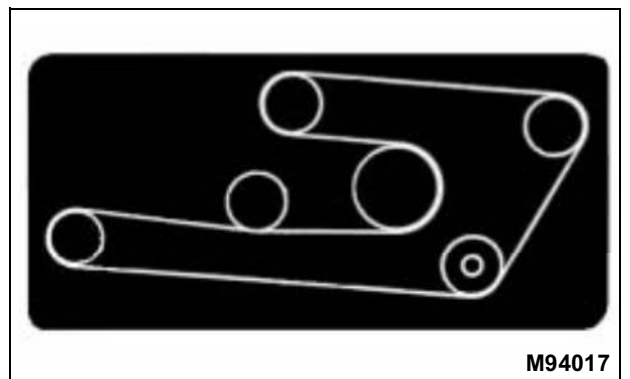

9. Plug in electrical connection (K) from blower PTO clutch assembly to corresponding plug on Front Mower wiring harness.

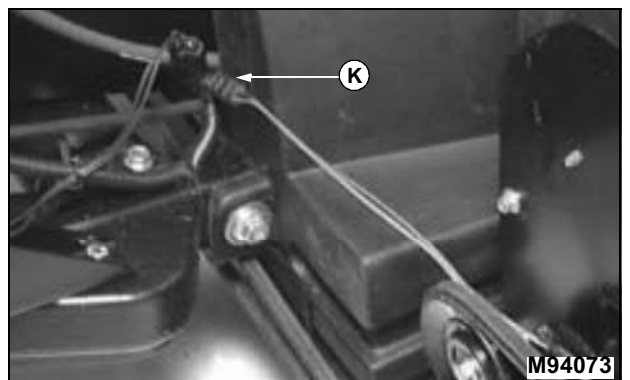

INSTALLING

⚠ CAUTION: Help prevent serious bodily injury from entanglement in a belt or pulley. NEVER operate blower without belt shield installed.

10. Install belt shield (L).

- Fasten belt shield to blower with the shield reinforcement strap (M), flat washer (N) and three locknuts (O).

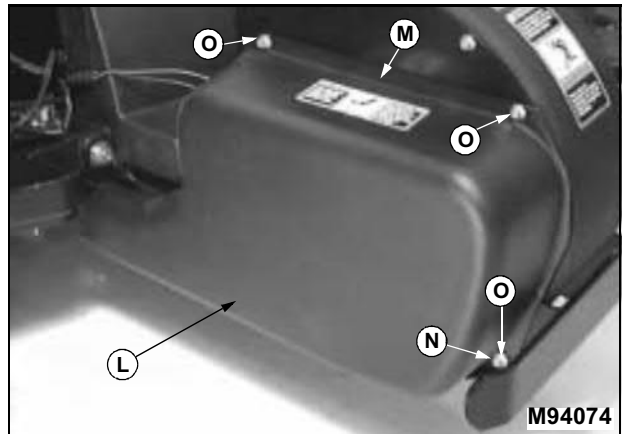

11. Lower Front Mower cowl.

12. Carefully raise collection box into position on top of cowl.

13. Connect MCS dump linkage.

- Install clevis pin (P), flat washer (Q) and locking ring (R).

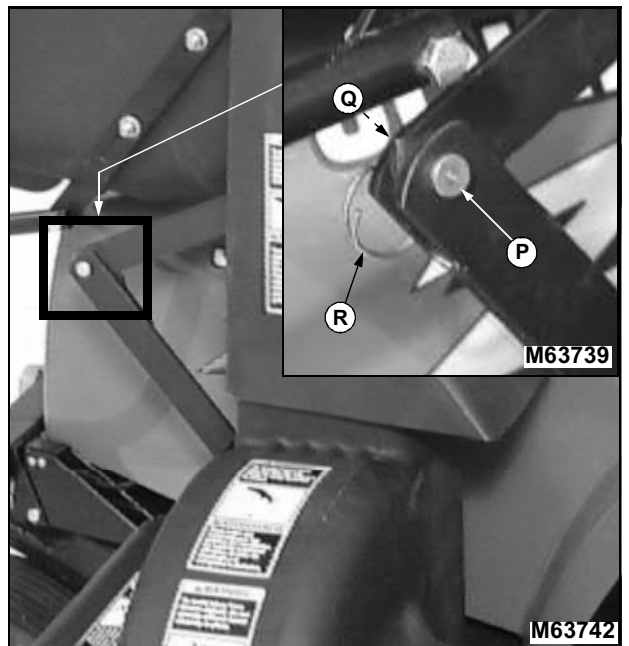

14. Move handle inside the handle locking bracket (S) and secure in position with dump handle latch (T).

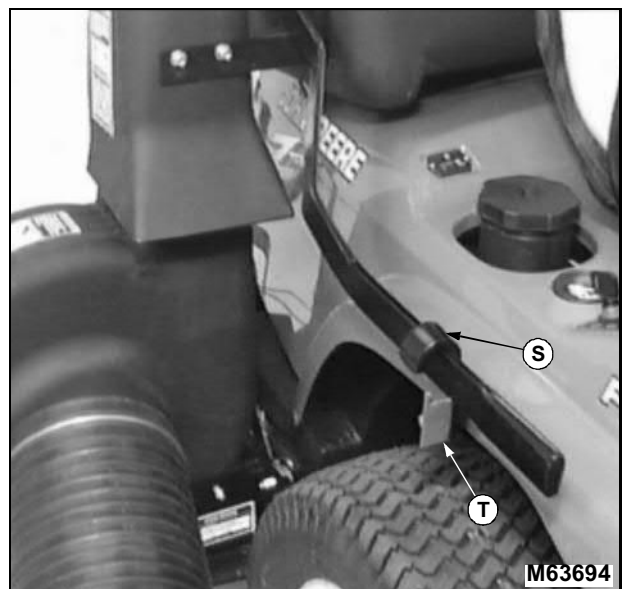

INSTALLING

15. Install clevis pin locking rings (U) to secure collection box and frame assembly to the Front Mower.



16. Install mower deck boot (V).

- Slide boot into position under bracket (W). Align boot mounting holes with bracket mounting holes.
- Turn plastic knobs (X) clockwise to secure boot in position.

Picture Note: Photo shows boot installed on the 60-Inch mower deck.

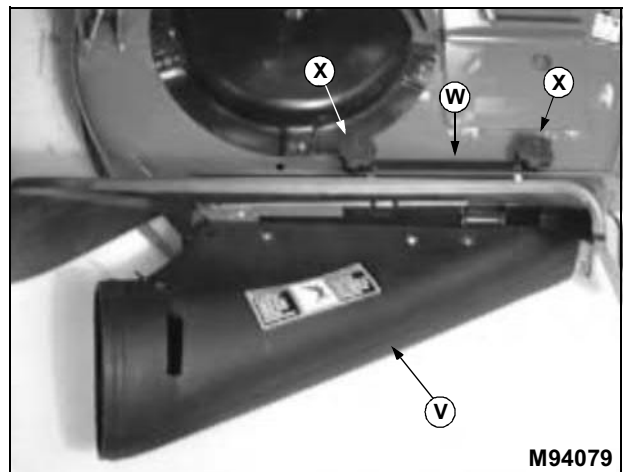

17. Install hose (Y) between blower and mower deck boot.

- Push hose onto mower deck boot.

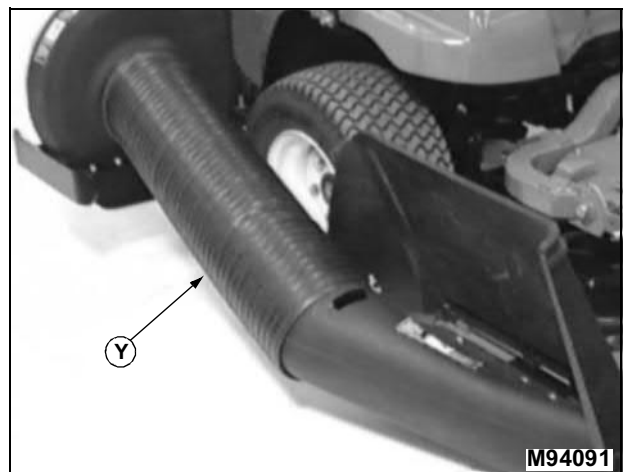



Suggest:

If the above button click is invalid.

Please download this document

first, and then click the above link

to download the complete manual.

Thank you so much for reading

REMOVING

Park Vehicle Safely

- Stop vehicle on a level surface, not on a slope.
- Disengage PTO.
- Engage park brake.
- STOP the engine.
- Remove the key.
- Before you leave the operator's seat, wait for the engine and all moving parts to STOP.

Removing the MCS

CAUTION: Help avoid serious personal injury. Stop front mower engine and wait for all moving parts to stop before removing the MCS.

1. Park Front Mower on a hard level surface.
2. Stop engine and engage park brake.
3. Remove hose (A) between blower and mower deck boot.
 - Pull hose from mower deck boot.

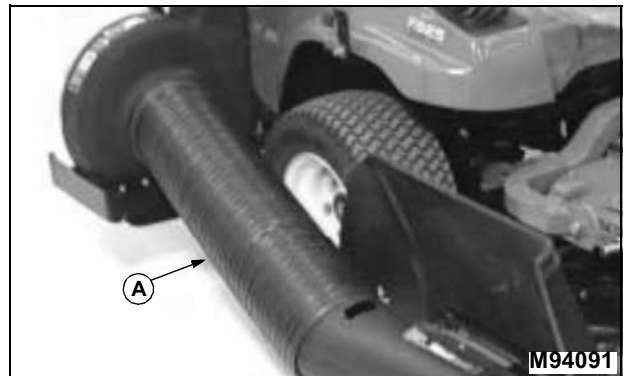

4. Remove boot (B).
 - Loosen both knobs (C) and remove boot.

Picture Note: Photo shows boot installed on the 60-inch mower deck.

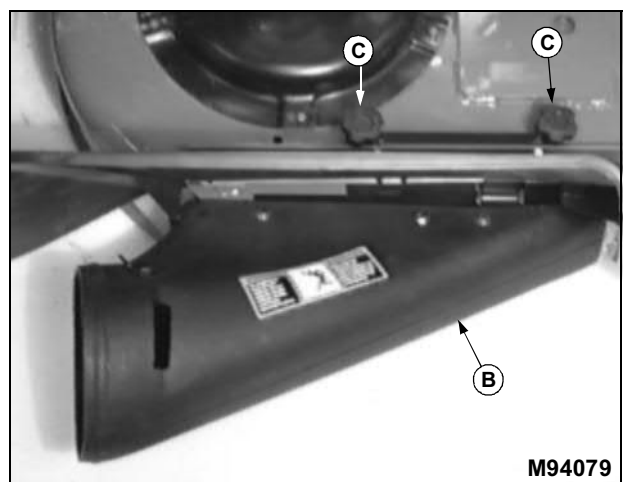

<https://www.ebooklibonline.com>

Hello dear friend!

Thank you very much for reading.

Enter the link into your browser.

The full manual is available for immediate download.

<https://www.ebooklibonline.com>