

M10, M21, and M23 Walk-Behind Mowers

Serial No. (010,001 -)



OPERATOR'S MANUAL

John Deere
Worldwide Commercial And
Consumer Products Division
OMGC00037 K7

North American Version
Litho in U.S.A.
English

ASSEMBLY

Unfold Handles

IMPORTANT: Prevent damage to mower control cables when installing handle assembly. **DO NOT** pinch or crimp the control cables. Control cables must be inside of handle and unrestricted before tightening hardware.

1. Carefully remove mower from shipping carton.
2. Loosen knob (A) approximately 25 mm (1 in.) on each side of upper handle.
3. Remove knob (B) and carriage bolt from each side.
4. Carefully pull folded handle assembly rearward.
5. Rotate slotted bracket (C) to match a desirable height setting with hole in handle.
6. Install carriage bolt (D) from the inside through hole in slotted bracket (C) and through handle on each side of handle. Use same hole on each side.
7. Install and tighten knob (B) on each bolt. Both handle knobs should be positioned on the outside of the handles.

NOTE: If handle height is not satisfactory, move handle to another hole and height position. Bolts must travel within slotted adjustment brackets and come to rest within one of the three height setting positions (E) before tightening.

8. Pivot upper portion of handle assembly to a straight and aligning position. Hold handle and tighten knob (A) on each side.

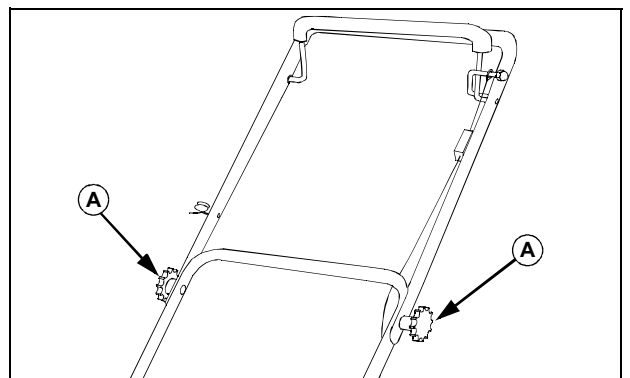
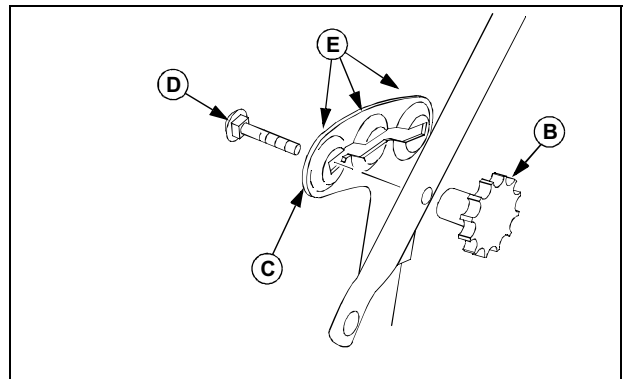
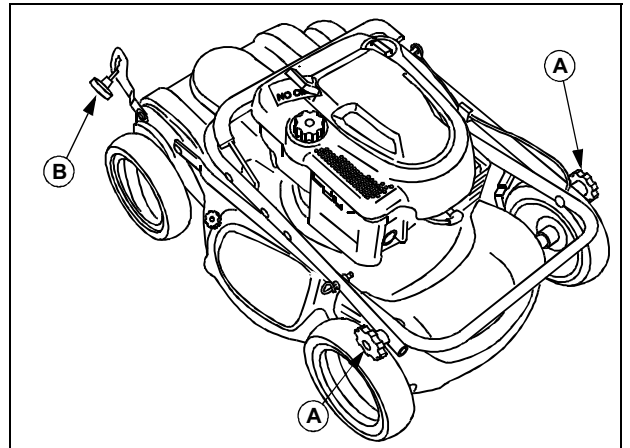

<https://www.ebooklibonline.com>

Hello dear friend!

Thank you very much for reading.

Enter the link into your browser.

The full manual is available for immediate download.

<https://www.ebooklibonline.com>

ASSEMBLY

Install Starter Rope

NOTE: To make installation of the starter rope onto the rope guide easier, hold the blade control lever against the handle while pulling the starter rope.

Pull and install starter rope (A) onto rope guide (B) mounted on the right side of the handle.

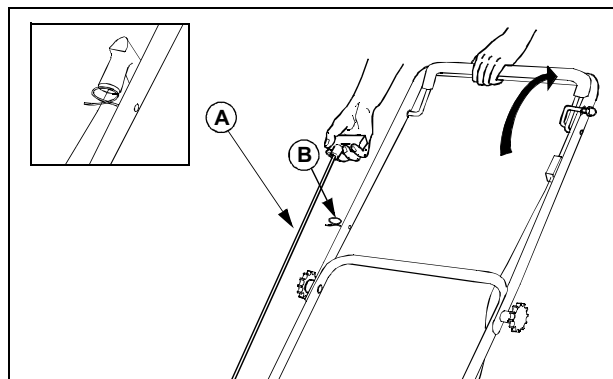

Add Engine Oil

IMPORTANT: ENGINE IS SHIPPED WITHOUT OIL.

You MUST add oil before running the engine. See Engine Operator's Manual for oil information.

1. Park mower on a level surface.
2. Turn oil dipstick (A) 1/4 turn to the left and remove it.
3. Add 0.6 L (20 oz) oil into dipstick tube.
4. Check oil level:
 - Install dipstick. Turn dipstick 1/4 turn to the right to tighten.
 - Remove dipstick.
 - Check oil level. Oil should be to the FULL mark (B). If not, add oil.
5. Install and tighten dipstick.
6. Remove "NO OIL" tag from top of engine.

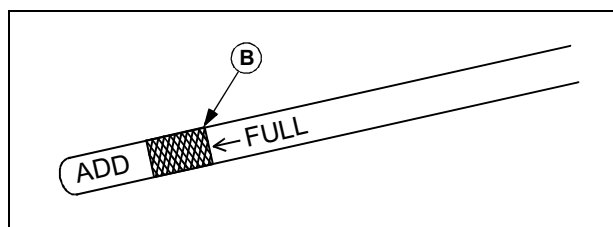
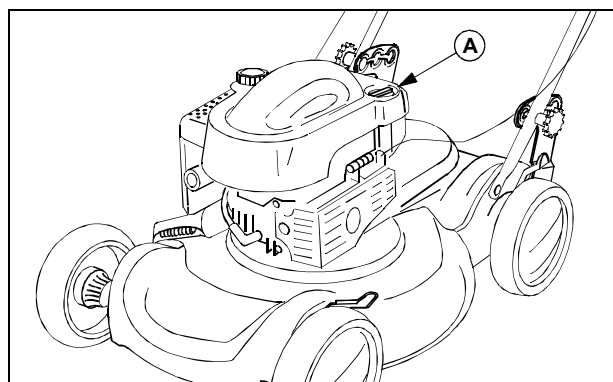

ASSEMBLY

Install Grass Bag

CAUTION: DO NOT operate mower unless mulch cover or grass bag and bagging chute are in place.
Bagging chute MUST be removed and mulch cover secured in place when grass bag is not being used.

1. Loosen mulch cover knob (A).
2. Lift and hold spring loaded mulch cover (B) up.
3. Install bagging chute:
 - Slide bagging chute (C) into position under the mulch cover mounting bracket (D).
 - Insert bagging chute tab (E) into rear mower shield slot (F).
 - Align hole in bagging chute over threaded hole in deck.
 - Install and tighten knob (G).

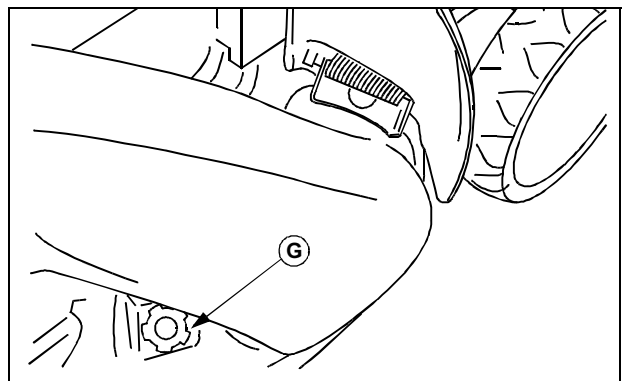
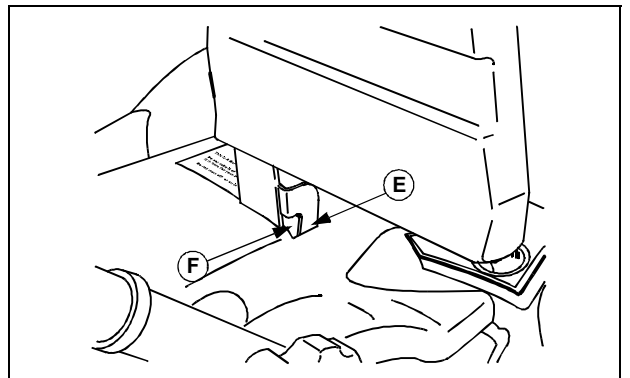
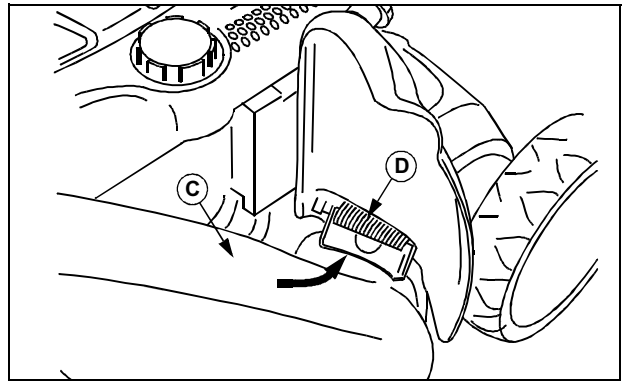
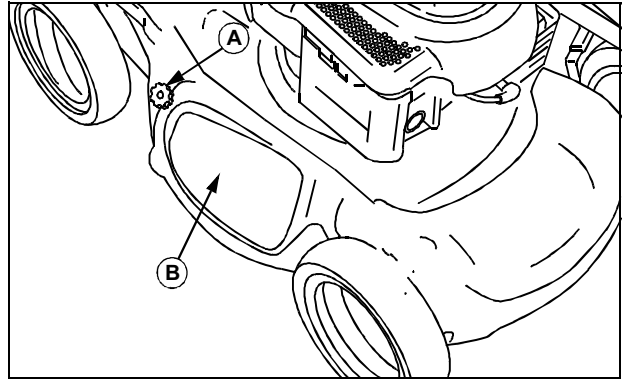

ASSEMBLY

4. Hang grass bag on lower handlebar.

NOTE: Doors (H) on grass bag must be closed prior to installation onto the bagging chute.

5. Open spring loaded bagging chute safety door (I).

6. Install grass bag onto bagging chute by inserting grass bag handle (J) into slots (K) and clasp (L) on top of bagging chute.

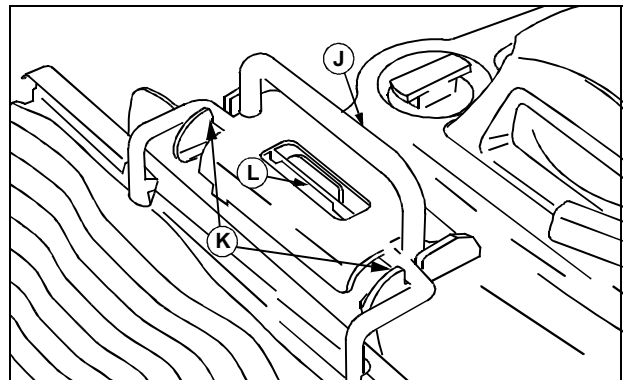
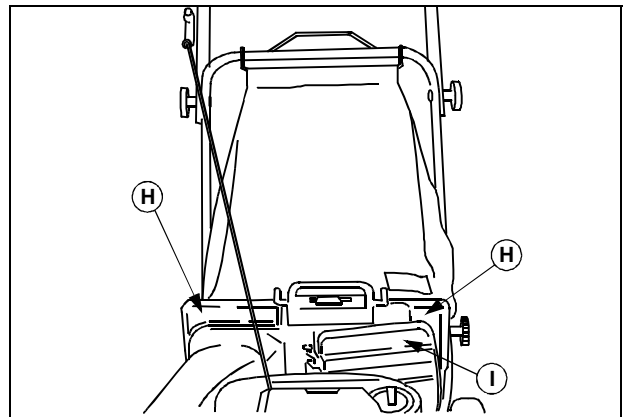

Test Mower

1. Connect spark plug wire (A) to spark plug.

IMPORTANT: See Engine Operator's Manual for fuel information.

2. Put enough fuel in fuel tank to test mower operation.

3. Start engine and check mower operation. (See Operating section).

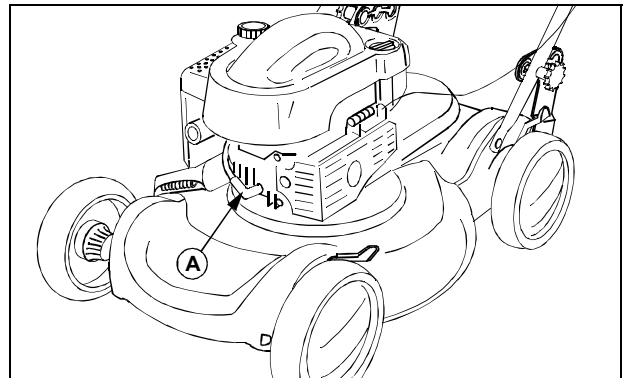

SAFETY SIGNS

Safety-Alert Symbol

Read and recognize safety information. Be alert to the potential for personal injury when you see this safety-alert symbol.

On your machine safety labels, the words DANGER, WARNING, and CAUTION are used with this safety-alert symbol. DANGER identifies the most serious hazards. In this manual, the word CAUTION and this symbol call attention to safety messages.

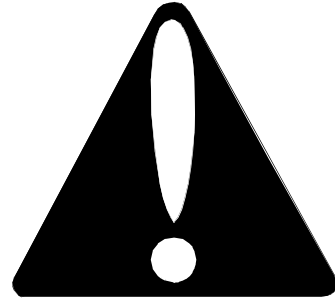

Machine Safety Labels

Avoid serious injury or death:

- Read the Owner's Manual.
- Go across slopes, not up and down.
- Do not mow when children or others are around.
- Look down and behind before and while mowing backwards.
- Remove objects that could be thrown by the blade.
- Keep safety devices in place and working

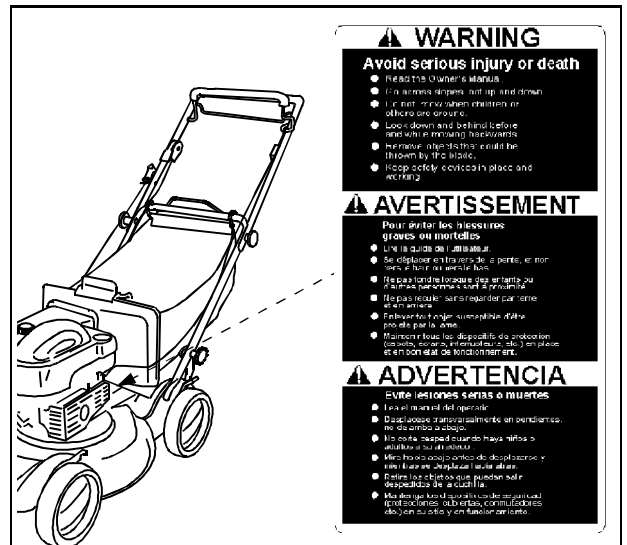

Rotating blade and thrown objects:

- Do not put hands or feet under or into mower when engine is running.
- Before mowing, clear area of objects that may be thrown by blade.

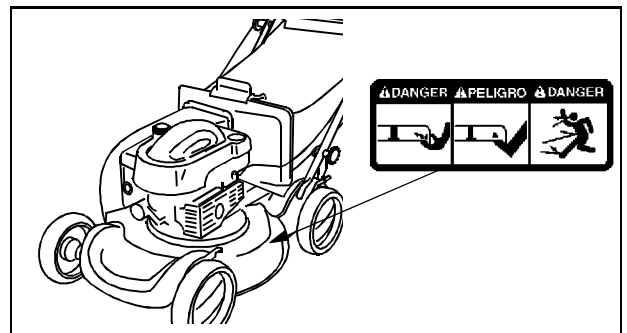

Cutting blade:

Keep hands and feet away.

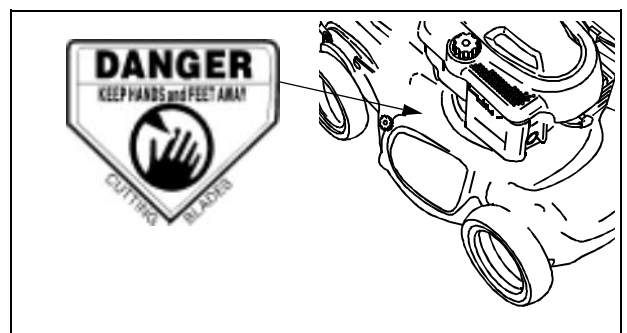

SAFETY SIGNS

Guard and grass catcher:

Operate only if this guard or entire grass catcher is in place.

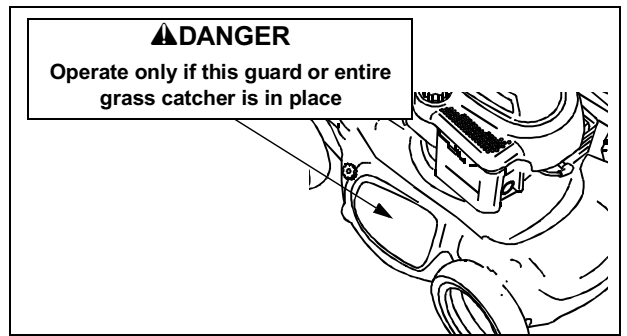

Grass bag:

- Bag is subject to wear and deterioration.
- Check bag frequently. Replace when necessary.
- Use Sabre bag or equivalent to comply with safety specifications.

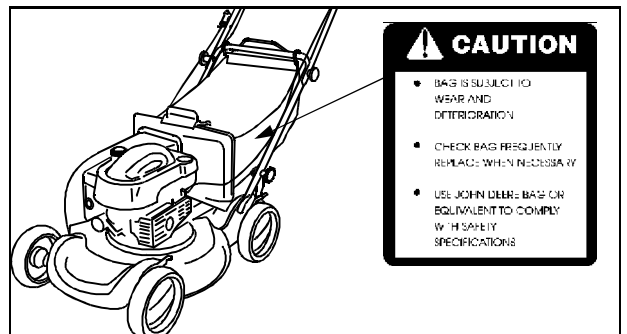

Bagging chute:

- Read Operator's Manual for proper installation and operation.
- Thrown objects, do not mow without bagging chute or guard door in place.
- Rotating blade, stop engine before lifting door and clearing bagging chute.

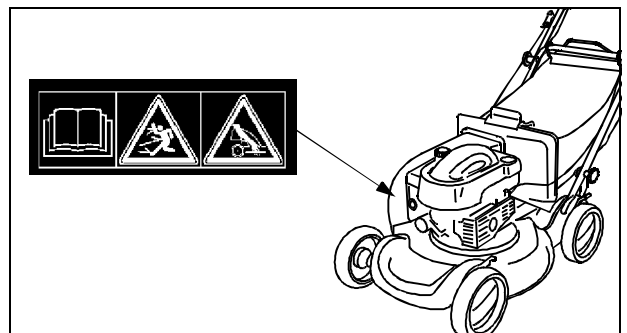

Bagging chute safety door:

- Thrown objects, do not mow without bagger or bagging chute safety door in place.
- Rotating blade, stop engine before opening safety door and clearing bagging chute.
- Do not open or remove safety shields while engine is running.

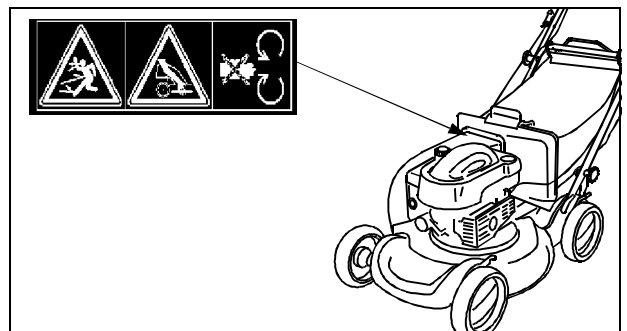



Suggest:

If the above button click is invalid.

Please download this document

first, and then click the above link

to download the complete manual.

Thank you so much for reading

SAFETY SIGNS

Certification Label

This OPEI label on your mower indicates that this model has been certified by an independent laboratory for compliance with American National Standard B-71.1-1996, "Safety Specifications" for Power Lawn Mowers, Lawn and Garden Tractors, and Lawn Tractors.

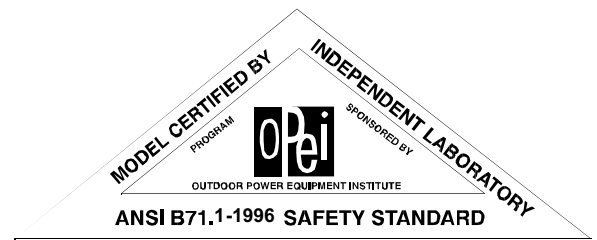

<https://www.ebooklibonline.com>

Hello dear friend!

Thank you very much for reading.

Enter the link into your browser.

The full manual is available for immediate download.

<https://www.ebooklibonline.com>