

**John Deere
JD862
Scraper**

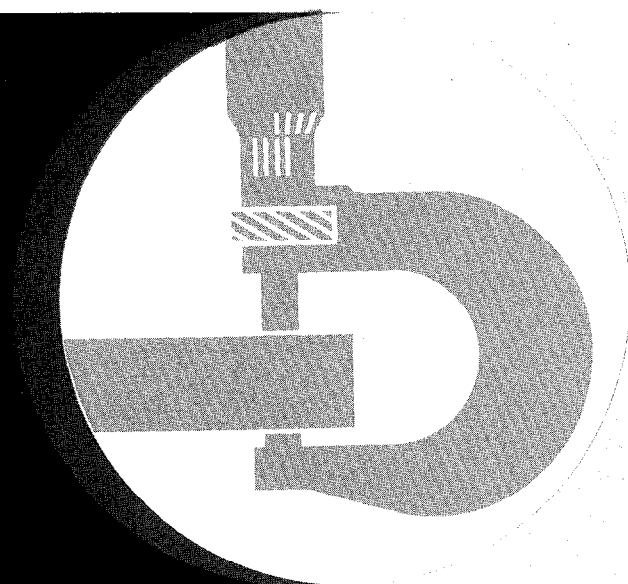

TECHNICAL MANUAL

TM-1212

LITHO IN U.S.A. (T) New

JD862 SCRAPER Technical Manual TM-1212 (Sep-84)

SECTION AND GROUP CONTENTS OF THIS MANUAL

SECTION I - GENERAL INFORMATION

- Group I - Contents, Index and Page List
- Group II - Introduction and Safety Information
- Group III - General Specifications
- Group IV - Predelivery, Delivery, and After-Sale Services
- Group V - Fuels and Lubricants

SECTION 1 - WHEELS

- Group 0110 - Powered Wheels and Fastenings
- Group 0120 - Non-Powered Wheels and Fastenings
- Group 0199 - Specifications and Special Tools

SECTION 2 - AXLES AND SUSPENSION SYSTEMS

- Group 0201 - Drive Axle Housing and Support
- Group 0210 - Differential or Bevel Drive
- Group 0225 - Input Drive Shafts and U-Joints
- Group 0230 - Non-Powered Wheel Axles
- Group 0250 - Axle Shaft, Bearings, Reduction Gears
- Group 0260 - Hydraulic System
- Group 0299 - Specifications and Special Tools

SECTION 3 - TRANSMISSION

- Group 0325 - Input Drive Shafts and U-Joints
- Group 0341 - Housings and Covers
- Group 0342 - Mounting Parts
- Group 0350 - Gears, Shafts, Bearings, and Power Shift Clutch
- Group 0360 - Hydraulic System
- Group 0399 - Specifications and Special Tools

SECTION 4 - ENGINE

- Group 0400 - Removal and Installation
- Group 0401 - Crankshaft and Main Bearings
- Group 0402 - Camshaft and Valve Actuating Means
- Group 0403 - Connecting Rods and Pistons
- Group 0404 - Cylinder Block
- Group 0407 - Oiling System
- Group 0408 - Ventilating System
- Group 0409 - Cylinder Head and Valves
- Group 0410 - Exhaust Manifold
- Group 0413 - Fuel Injection System
- Group 0414 - Intake Manifold
- Group 0416 - Turbocharger
- Group 0417 - Water Pump
- Group 0418 - Thermostats, Housings, and Water Piping
- Group 0419 - Oil Cooler
- Group 0420 - Fuel Filter
- Group 0421 - Fuel Transfer Pump
- Group 0422 - Starting Motor and Fastenings
- Group 0423 - Alternator and Generator Mounting
- Group 0429 - Fan Drive
- Group 0433 - Flywheel, Housing and Fastenings
- Group 0499 - Specifications and Special Tools

SECTION 5 - ENGINE AUXILIARY SYSTEMS

- Group 0505 - Cold Weather Starting Aids
- Group 0510 - Cooling Systems
- Group 0515 - Speed Controls
- Group 0520 - Intake System
- Group 0530 - External Exhaust System
- Group 0540 - Mounting Frame
- Group 0560 - External Fuel Supply Systems
- Group 0599 - Specifications and Special Tools

SECTION 6 - TORQUE CONVERTER

- Group 0641 - Housing and Cover
- Group 0651 - Turbine, Gears, Shaft, etc.
- Group 0660 - Hydraulic System
- Group 0699 - Specifications and Special Tools

Copyright © 1984
DEERE & COMPANY
Moline, Illinois
All Rights Reserved
Previous Edition
Copyright © 1979 DEERE & COMPANY

SECTION AND GROUP CONTENTS OF THIS MANUAL—Continued

- SECTION 9 - STEERING SYSTEM
Group 0960 - Hydraulic System
Group 0999 - Specifications and Special Tools
- SECTION 10 - SERVICE BRAKES
Group 1011 - Active Elements
Group 1015 - Controls Linkage
Group 1060 - Hydraulic System
Group 1099 - Specifications and Special Tools
- SECTION 11 - PARKING-EMERGENCY BRAKES
Group 1111 - Active Elements
Group 1115 - Controls Linkage
Group 1199 - Specifications and Special Tools
- SECTION 13 - MISCELLANEOUS VEHICLE
Group 1370 - Lubrication Systems
- SECTION 16 - ELECTRICAL SYSTEM
Group 1671 - Batteries, Support and Cables
Group 1672 - Alternator, Regulator and Charging System Wiring
Group 1673 - Lighting System
Group 1674 - Wiring Harness and Switches
Group 1675 - System Controls
Group 1676 - Instruments and Indicators
Group 1699 - Specifications and Special Tools
- SECTION 17 - FRAME, CHASSIS OR SUPPORTING STRUCTURE
Group 1740 - Frame Installation
Group 1746 - Frame Bottom Guards
Group 1799 - Specifications and Special Tools
- SECTION 18 - OPERATOR'S STATION
Group 1810 - Operator Enclosure
Group 1821 - Seat and Seat Belt
Group 1830 - Heating and Air Conditioning
Group 1899 - Specifications and Special Tools
- SECTION 19 - SHEET METAL AND STYLING
Group 1910 - Hood or Engine Enclosure
Group 1913 - Miscellaneous Shields
Group 1921 - Grille and Grille Housing
Group 1927 - Fenders
Group 1999 - Specifications and Special Tools
- SECTION 20 - SAFETY, CONVENIENCE AND MISCELLANEOUS
Group 2004 - Horn
Group 2006 - Cigar Lighter
- SECTION 21 - MAIN HYDRAULIC SYSTEM
Group 2160 - Hydraulic System
Group 2199 - Specifications and Special Tools
- SECTION 35 - SCRAPER AND HAULAGE DEVICE
Group 3501 - Blades or Cutting Edges
Group 3540 - Frames
Group 3560 - Hydraulic System
Group 3599 - Specifications and Special Tools
- SECTION 36 - CONVEYOR AND ELEVATING DEVICE
Group 3612 - Conveyor or Mast
Group 3640 - Conveyor and Elevating Device Frame
Group 3650 - Gear Box
Group 3660 - Hydraulic System
Group 3699 - Specifications and Special Tools
- SECTION 90 - SYSTEM TESTING
Group 9005 - General Information - Seven Basic Steps of Testing and Diagnosis
Group 9010 - Engine
Group 9015 - Electrical
Group 9020 - Power Train
Group 9025 - Hydraulic System (Flow Meter)
Group 9030 - Miscellaneous Components
Group 9031 - Heating and Air Conditioning
Group 9035 - Specifications and Special Tools

The specifications and design information contained in this manual were correct at the time it was printed. It is John Deere's policy to continually improve and update our machines. Therefore, the specifications and design information are subject to change without notice. Wherever applicable, specifications and design information are in accordance with SAE and ICED standards.

<https://www.ebooklibonline.com>

Hello dear friend!

Thank you very much for reading.

Enter the link into your browser.

The full manual is available for immediate download.

<https://www.ebooklibonline.com>

Drive plate	1830-6
Drop train gears, transmission	0350-50

E

Ejector gate	3540-5
Ejector gate cylinders	3560-10
Electrical system	1671-1
Electrical system testing:	
Charging circuit	9015-18
Complete electrical schematic	9015-49
Component location drawing	9015-3
Diagnosing malfunctions	9015-8
Electrical block diagram	9015-7
Electrical wiring diagram	9015-50
Elevator and bowl circuits	9015-30
Gauges and indicator circuits	9015-23
Lighting circuit	9015-21
Miscellaneous accessories	9015-28
Precautions	9015-12
Starting circuit	9015-15
Testing and adjustments	9015-14
Transmission control circuit	9015-38
Visual inspection	9015-13
Elevating device	3612-3
Elevator chain	3612-7
Elevator circuit board	1675-1
Elevator control circuit	1675-1
Elevator drive motor, hydrostatic	3660-28
Elevator drive pump, hydrostatic	3660-1
Elevator frame	3640-1
Elevator pump	3660-5
Elevator switch	1675-1
Engine	0400-5
Engine auxiliary systems	0505-3
Engine coolant heater	0505-4
Engine coolant temperature gauge	1676-6
Engine front mount isolators	0540-2
Engine oil pressure gauge	1676-6
Engine oil pump	0407-1
Engine oiling system	0407-1
Engine rear mount isolators	0540-1
Engine service door	1910-6
Engine shut-off cable	0515-3
Engine system testing:	
Component location drawing	1910-2
Diagnosing malfunctions	1910-8
General information	1910-6
Introduction	1910-1
Testing and adjustment	1910-13
Visual inspection	1910-11
Evaporator	1830-21
Exhaust manifold	0410-1
Exhaust systems, external	0530-1
Expansion valve	1830-23

External exhaust systems	0530-1
External fuel supply systems	0560-1

F

Fan	0510-4
Fan belt tightener	0429-1
Fan drive	0429-1
Fan drive support	0429-3
Fan shroud	0510-1
Feedback potentiometer	1675-2
Fenders, left front	1927-2
Fenders, right front	1927-1
Fenders, scraper	1927-3
Filter, air	0520-1
Filter, axle hydraulic oil	0260-6
Filter/conditioner, coolant	0510-4
Filter relief valve	0360-28, 2160-36
Flywheel, housing and fastenings	0433-1
Follow-up control steering cylinders	0960-17
Frame bottom guards	1746-1
Frame, draft	3540-2
Frame, elevator	3640-1
Frame, main	1740-1
Frame, mounting	0540-1
Frame, rear	3540-1
Fuel filter	0420-1
Fuel gauge	1676-7
Fuel injection nozzles	0413-7
Fuel injection pump	0413-1
Fuel injection system	0413-1
Fuel line	0560-5
Fuel supply pump	0560-3
Fuel supply systems, external	0560-1
Fuel tank	0560-1
Fuel transfer pump	0421-1
Fuses	1674-5

G

Gauge, engine coolant temperature	1676-6
Gauge, engine oil pressure	1676-6
Gauge, fuel	1676-7
Gauge, hydrostatic pressure	1676-3
Gauge, transmission lube pressure	1676-3
Gauge, transmission oil pressure	1676-2
Gauge, transmission oil temperature	1676-5
Gear selector switch	1675-4
Gearbox	3650-1
Gears, shafts, bearing and power shift clutch, transmission	0350-1
General specifications	I-III-1
Greases	I-V-2
Grille and grille housing	1921-1

H	
Heat shield	1913-2
Heater, engine coolant	0505-4
Heating system	1830-1
Heating system testing:	
Component location	9031-3
Diagnosis and testing	9031-1
System service	9031-12
High and low refrigerant pressure	
switches	1830-26
High beam indicator	1676-10
Hood	1910-3
Hood, left	1910-4
Horn	2004-3
Horn switch	2004-3
Housing and cover, torque converter	0641-3
Housing and covers, transmission	0341-1
Hydraulic filter restriction indicator	1676-10
Hydraulic fitting installation and service	
recommendations	2160-3
Hydraulic pump and stroke control valve	
(132 cm ³ 8.00 in. ³)	2160-6
Hydraulic pump, three-section	0360-18, 2160-23
Hydraulic reservoir	2160-38
Hydraulic system, axles and suspension	
systems	0260-1
Hydraulic system, conveyor and	
elevating device	3660-1
Hydraulic system (flow meter) testing:	
Component location	9025-2
Cycle times	9025-80
Diagnosing malfunctions	9025-66
General information	9025-13
Hydraulic schematic	9025-10
Special procedures	9025-76
System explanations	9025-14
Testing and adjustment	9025-82
Visual inspection	9025-65
Hydraulic system, main	2160-3
Hydraulic system, service brakes	1060-1
Hydraulic system, transmission	0360-1
Hydrostatic elevator drive motor	3660-28
Hydrostatic elevator drive pump	3660-1
Hydrostatic pressure gauge	1676-3
I	
Idler, adjusting	3612-10
Idler assembly, upper	3612-3
Idler, lower	3612-5
Input drive shaft and U-joints, transmission	0325-3
Input drive shafts and U-joints	0225-1
Input shaft assembly, transmission	0350-5
Instruments and indicators	1676-1
Intake manifold	0414-1
Intake system	0520-1
Isolators, engine front mount	0540-2
Isolators, engine rear mount	0540-1

K	
Key switch	1674-2
L	
Left front fenders	1927-2
Left hood	1910-4
Lighting system	1673-1
Line, fuel	0560-5
Linkage, speed control	0515-1
Low pressure warning switch	1060-5
Lower idler	3612-5
Lubrication	I-V-1
Lubrication relief valve	0360-15
Lubrication system, central	1370-3

M	
Magnetic pick-up	1675-4
Main frame	1740-1
Main hydraulic oil filter	2160-35
Mast	3612-3
Meter, service	1676-4
Miscellaneous components testing:	
Adjustments	9030-1
Miscellaneous shields	1913-1, 1999-1
Miscellaneous vehicle	1370-1
Motor, blower	1830-27
Mounting frame	0540-1
Mounting parts, transmission	0342-1

N	
Non-powered wheel axles	0230-1
Non-powered wheels	0120-1

O	
Oil cooler, engine	0419-1
Oil cooler, transmission	0360-30
Oil filter, main hydraulic	2160-35
Oil filter, transmission	0360-27
Oil pressure regulating housing, engine	0407-4
Oils	I-V-2
Oscillation hitch	1740-7
Oscillation hitch pins	1740-9
Output shaft, transmission	0350-46

P	
Parking brake	1111-3, 9020-11
Parking brake indicator	1676-11
Parking-emergency brakes active elements	1111-3
Parking-emergency brakes controls linkage	1115-1
Pins and tapered sleeves	1740-8
Pins, oscillation hitch	1740-9
Pins, steering link	1740-9
Planetary assembly, transmission	0350-25
Planetary pack, transmission	0350-17

Potentiometer, command	1675-1
Potentiometer, feedback	1675-2
Power train testing:	
Component location	9020-3
Diagnosing malfunctions	9020-19
Power flow	9020-11
Testing and adjustments	9020-23
Powered wheels	0110-3
Precleaner	0520-3
Predelivery service	I-IV-1
Pressure control valves	2160-32
Pressure oil circuit relief valves	0960-12
Pump, axle hydraulic	0260-4
Pump, elevator	3660-5
Pump, fuel supply	0560-3
Pump, steering metering	0960-7

R

Radiator	0510-1
Receiver-dryer	1830-20
Reduction gear shaft, transmission	0350-15
Relays	1674-4
Resistors	1674-6
Reverse warning alarm	2004-3
Rocker arm assembly	0402-2

S

Scraper and haulage device hydraulic system	3560-1
Scraper bowl	3540-1
Scraper brakes	1011-4
Scraper fenders	1927-3
Seal, compressor shaft	1830-8
Seat	1821-1, 9030-3
Seat belt	1821-1
Service brakes	9020-11
Service brakes controls linkage	1015-1
Service brakes hydraulic system	1060-1
Service meter	1676-4
Sheet metal and styling	1910-1
Shield, heat	1913-2
Shields, miscellaneous	1913-1
Side panels	1810-4
Sliding floor	3540-3
Sliding floor cylinder	3560-10
Speed control linkage	0515-1
Speed controls	0515-1
Speedometer	1676-9
Solenoid	1675-2, 1675-5, 3560-9
Solenoid, starting aid	0505-3
Solenoid switch	0422-9
Special tools:	
Air conditioning system	1899-3
Air conditioning system testing	9035-27

Special tools—Continued:

Alternator, regulator and charging system wiring	1699-7
Batteries, support and cables	1699-6
Camshaft and valve actuating means	0499-35
Connecting rods and pistons	0499-37
Crankshaft and main bearings	0499-34
Cylinder block	0499-38
Cylinder head and valves	0499-39
Electrical system testing	9035-14
Engine removal and installation	0499-31
Engine system testing	9035-3
Frames	3599-5
Fuel injection system	0499-41
Heating system	1899-3
Heating system testing	9035-27
Hydraulic system	2199-10
Hydraulic system (flow meter) testing	9035-22
Powered wheels and fastenings	0199-2
Scraper and haulage device hydraulic system	3599-5
Service brakes hydraulic system	1099-6
Starting motor and fastenings	0499-46
Steering hydraulic system	0999-5
Transmission gears, shafts, bearings and power shift clutch	0399-23
Transmission housings and covers	0399-22
Transmission hydraulic system	0399-27
Turbocharger	0499-44
Water pump	0499-45
Specifications:	
Air conditioning system	1899-1
Air conditioning system testing	9035-26
Alternator and generator mounting	0499-28
Alternator, regulator and charging system wiring	1699-2
Axles and suspension systems hydraulic system	0299-6
Batteries, supports and cables	1699-1
Blades or cutting edges	3599-1
Camshaft and valve actuating means	0499-5
Connecting rods and pistons	0499-7
Cooling systems	0599-1
Crankshaft and main bearings	0499-2
Cylinder block	0499-9
Cylinder head and valves	0499-13
Differential or bevel drive	0299-2
Drive axle housing and support	0299-1
Electrical system testing	9035-7
Engine break-in	0499-1
Engine oil cooler	0499-24
Engine oiling system	0499-11
Engine system testing	9035-1
Exhaust manifold	0499-16
Fan drive	0499-29
Flywheel housings and fastenings	0499-30

Specifications—Continued:

Frame installation	1799-1
Frames	3599-2
Fuel filter	0499-25
Fuel injection system	0499-17
Heating and air conditioning system testing	9035-26
Heating system	1899-1
Heating system testing	9035-26
Hydraulic system	2199-1
Hydraulic system (flow meter) testing	9035-16
Intake manifold	0499-18
Lighting system	1699-4
Miscellaneous components testing	9035-25
Non-powered wheels and fastenings	0199-1
Parking-emergency brakes active elements	1199-1
Power train system testing	9035-16
Powered wheels and fastenings	0199-1
Scraper and haulage device hydraulic system	3599-3
Service brakes active elements	1099-1
Service brakes hydraulic system	1099-2
Starting motor and fastenings	0499-26
Steering hydraulic system	0999-1
Thermostats, housings and water piping	0499-23
Torque converter housing and cover	0699-1
Transmission gears, shafts, bearings and power shift clutch	0399-5
Transmission housing and covers	0399-2
Transmission hydraulic system	0399-15
Transmission input drive shafts and U-joints	0399-1
Transmission mounting parts	0399-4
Turbine, gears and shaft	0699-2
Turbocharger	0499-19
Water pump	0499-22
Wiring harness and switches	1699-5
Start aid switch	1674-3
Start switch	1674-3
Starting aid adapter, line and nozzle	0505-3
Starting aid solenoid	0505-3
Starting aids, cold weather	0505-3
Starting motor and fastenings	0400-2
Steering column	0960-3
Steering cylinders	0960-21
Steering hydraulic system	0960-3
Steering link pins	1740-9
Steering links	1740-7
Steering metering pump	0960-7
Steering system	0960-3
Steering valve	0960-11
Suction screen, transmission	0360-16
Switch, horn	2004-3
Switch, key	1674-2

Switch, start	1674-3
Switch, start aid	1674-3
Switch, windshield wiper	1674-3
System testing:	
Air conditioning system	9031-5
Electrical system	9015-1
Engine system	9010-1
Heating system	9031-1
Hydraulic system	9025-1
Miscellaneous	9030-1
Power train system	9020-1

T

Tachometer	1676-8
Tank, fuel	0560-1
Temperature control switch	1830-24
Thermostats, housings and water piping	0418-1
Three-section hydraulic pump	0360-18, 2160-23
Torque converter	0641-1, 9020-6
Torque converter clutch modulating valve	0360-11
Tractor brakes	1011-3
Transmission belly pan	1913-1
Transmission brake housings	0350-18, 0350-36
Transmission clutch pack assembly	0350-31
Transmission control box	1675-3
Transmission control circuit	1675-3
Transmission control valve	0360-1
Transmission drop train gears	0350-50
Transmission gears, shafts, bearings and power shift clutch	0350-1
Transmission hold and downshift switches	1675-5
Transmission housing and covers	0341-1
Transmission hydraulic system	0360-1
Transmission input drive shaft and U-joints	0325-3
Transmission input shaft assembly	0350-5
Transmission lube pressure gauge	1676-3
Transmission mounting parts	0342-1
Transmission oil cooler	0360-30
Transmission oil filter	0360-27
Transmission oil pressure gauge	1676-2
Transmission oil temperature gauge	1676-5
Transmission output shaft	0350-46
Transmission planetary assembly	0350-25
Transmission planetary pack	0350-17
Transmission, power shift	9020-8
Transmission reduction gear shaft	0350-15
Transmission suction screen	0360-16
Turbine, gears and shaft	0651-1
Turbocharger	0416-1
Turn indicators	1676-10

U

Upper idler assembly	3612-3
----------------------	--------

V		W	
Valve, bowl control	3560-1	Warning switch, low pressure	1060-5
Valve, brake	1060-7	Water pump	0417-1
Valve, compressor relief	1830-25	Wheels, non-powered	0120-1
Valve, differential lock	0260-1	Wheels, powered	0110-3
Valve, differential lock check	0260-5	Windshield wiper	1810-3, 9030-2
Valve, expansion	1830-23	Windshield wiper switch	1674-3
Valve, filter relief	0360-28, 2160-36	Wiring harness	1674-1
Valve lift check	0402-1		
Valve, lubrication relief	0360-15		
Valve, steering	0960-11		
Valve, torque converter clutch modulating	0360-11		
Valve, transmission control	0360-1		
Valves, control circuit relief	0960-12		
Valves, pressure control	2160-32		
Valves, pressure oil circuit relief	0960-12		
Vehicle, miscellaneous	1370-1		
Ventilating system	0408-1		
Vibration damper	0401-7		
Voltmeter	1676-7		

Group II

INTRODUCTION AND SAFETY INFORMATION

INTRODUCTION

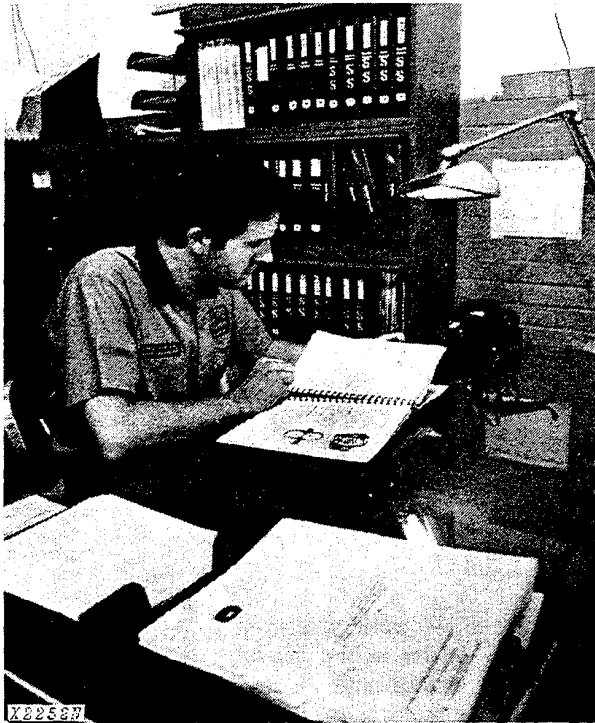

Use FOS Manuals for Reference

This technical manual is part of a twin concept of service:

The two kinds of manuals work as a team to give you both the general background and technical details of shop service.

•FOS Manuals—for reference

Fundamentals of Service (FOS) Manuals cover basic theory of operation, *fundamentals* of trouble shooting, *general* maintenance, and *basic* types of failures and their causes. FOS Manuals are for training new personnel and for reference by experienced service technicians.



When a service technician should refer to a FOS Manual for more information, a FOS symbol like the one at the left is used in the technical manual.

•Technical Manuals—for actual service

Technical Manuals are concise service guides for *specific* machines. Technical manuals are on-the-job guides containing only the vital information needed by an experienced service technician.



Use Technical Manuals for Actual Service

This technical manual was written for you—an experienced service technician. Keep it in a permanent binder in the shop where it is handy. Read it when you need to know correct service procedures or specifications.

Some features of this manual:

- Inside front cover - "Table of Contents".
- Section I - Contents, safety information, general specifications, general services and fuels and lubricants.
- Sections 1 through 42 - Removal, repair, testing (components removed), installation, and adjustment.
- Section 90 - Detailed explanation of system operation, diagnosis, visual inspection, testing, and adjustments.
- Specifications are listed and illustrated at the end of each section.

MAINTENANCE WITHOUT ACCIDENT WORK SAFELY



T27999N

 This safety symbol is used for important safety messages. When you see this symbol, follow the safety message to avoid personal injury.

EVERY EMPLOYER HAS A SAFETY PROGRAM. KNOW WHAT IT IS!

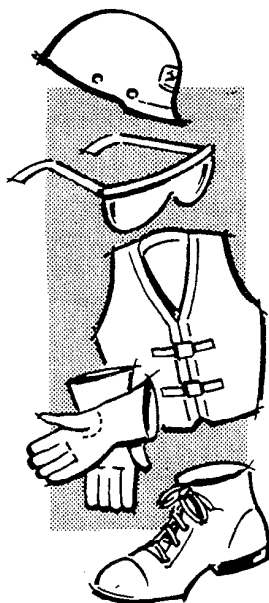

T27501N

See your shop supervisor for specific instructions on a job, and the safety equipment required.

For instance, you may need: Hard hat, safety shoes, safety goggles, heavy gloves, reflector vests, ear protectors, respirator.

RIGHT



WRONG

T27502N

BE ALERT!

Plan ahead — work safely — know how to use a first aid kit and a fire extinguisher — and where to get assistance.

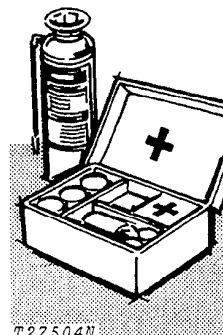

T27504N

Maintenance Area

Make sure the maintenance area has enough ventilation.

Keep the maintenance area CLEAN AND DRY. Oily and wet floors are slippery. Greasy rags are a fire hazard. Wet spots are dangerous when working with electrical equipment.

Keep starting aids in a cool, well-ventilated place, out of reach of unauthorized personnel.

MAINTENANCE WITHOUT ACCIDENT

AVOID FIRE HAZARDS

Fuel Is Dangerous!

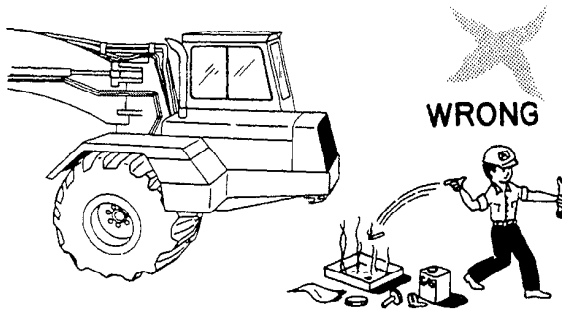

T71141

Do not smoke while putting fuel in the fuel tank.

Do not smoke while working with material that will start on fire easily.

Stop the engine before filling the fuel tank.

Do not use gasoline or diesel fuel for cleaning parts. Use solvents that will not start on fire.

Battery Gas Is Highly Flammable!

When charging batteries, be sure there is enough ventilation.

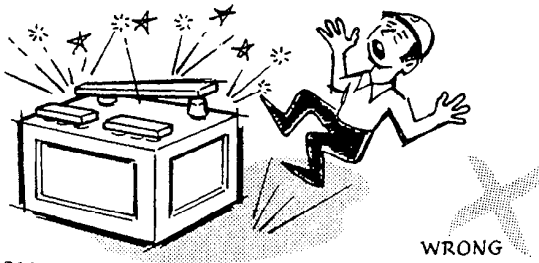

T27506N

Do not check the battery charge by putting metal objects across the terminals.

Do not let sparks or open flame near batteries.

Do not smoke near battery.

Flame Is Not a Flashlight!

NEVER USE OPEN FLAME AROUND THE MACHINE.

KNOW WHERE FIRE EXTINGUISHERS ARE KEPT!

UNDER ALL MAINTENANCE CONDITIONS

Do not work on the equipment unless you are approved to do so. Then be sure you know the safe and correct procedure.

Never work on equipment while it is being operated.



T71142

When the engine is running, avoid working on equipment.

If you must work on the machine with the engine running, ALWAYS USE TWO service technicians. One must be at the controls. The other must be within sight of the operator.

KEEP HANDS AWAY FROM MOVING PARTS

Put a support under all raised equipment.

Never work under a raised bowl.

Lower the bowl to the ground.

If the machine is on a slope, use blocks to hold it in place.

Do not lift heavy parts by yourself. Use hoisting equipment for this.

TAKE CARE! WATCH OUT FOR OTHER PEOPLE IN THE AREA

When drilling, grinding, or hammering metal, wear safety glasses.

BE CAREFUL DURING SERVICE AND REPAIR



Keep ALL equipment free of dirt and oil.

Clean oil, grease, mud, ice or snow from the operator's station, steps and hand rails.

When getting the engine ready for storage, remember that inhibitor changes easily into gas and is dangerous. After adding the inhibitor, seal and tape openings. When you are not using the inhibitor, keep the can tightly closed.

Do not remove the radiator cap unless the engine is cool. First, loosen the cap slowly to the stop. Then release all pressure in the cooling system before removing the cap.

Check the exhaust system regularly for leaks.

Release hydraulic pressure before working on the hydraulic system. Lower the bowl to the ground. Stop the engine. Move the steering wheel until the bowl does not move.

When checking hydraulic pressure, be sure to use the correct test gauge.

Before working on the fuel system, close the fuel shutoff valve.

Before working on the electrical system, or making a major overhaul, disconnect the batteries.

KNOW EQUIPMENT IS READY!

All parts should be in good condition and fastened in place.

CHECK IT OUT!

- ROLL-OVER PROTECTIVE STRUCTURE
- SEAT BELT, ETC.

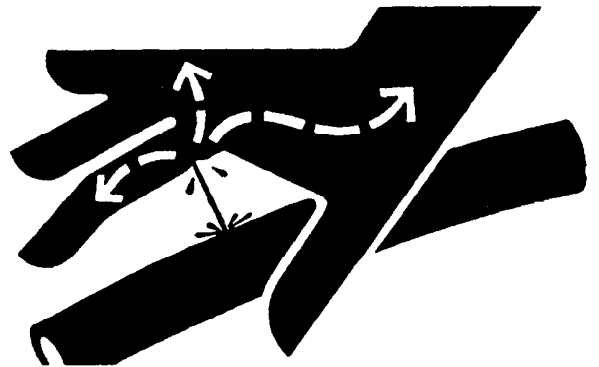
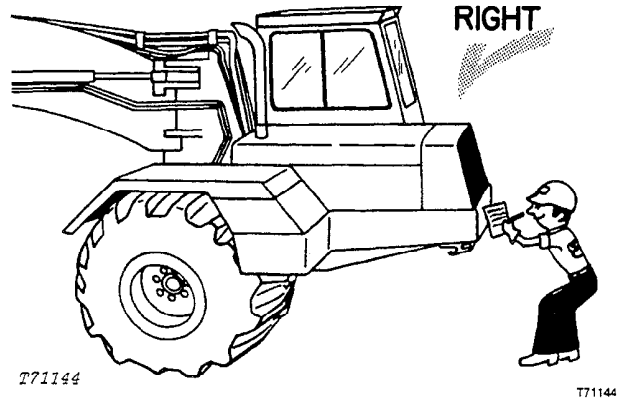

Escaping fluid under pressure can penetrate the skin causing serious injury. Relieve pressure before disconnecting hydraulic or other lines. Tighten all connections before applying pressure. Keep hands and body away from pinholes and nozzles which eject fluids under high pressure. Use a piece of cardboard or paper to search for leaks. Do not use your hand.

If ANY fluid is injected into the skin, it must be surgically removed within a few hours by a doctor familiar with this type injury or gangrene may result.

Avoid possible injury or death from machinery runaway.

Do not start engine by shorting across starter terminals. Machine will start in gear and will move if normal circuitry is bypassed

NEVER start engine while standing on ground. Start engine only from operator's seat, with transmission in neutral, direction selector lever in neutral, and park brake applied.

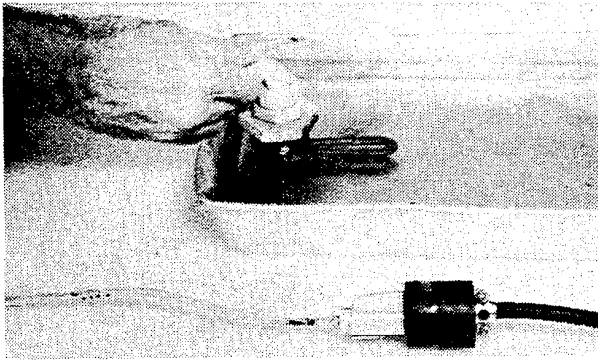

T87098

Test coolant heater in liquid only.

Use a heavy-duty grounded cord to connect coolant heater to electrical power.

Do not plug into electrical power unless heating element is immersed in coolant. Sheath could burst and result in personal injury.

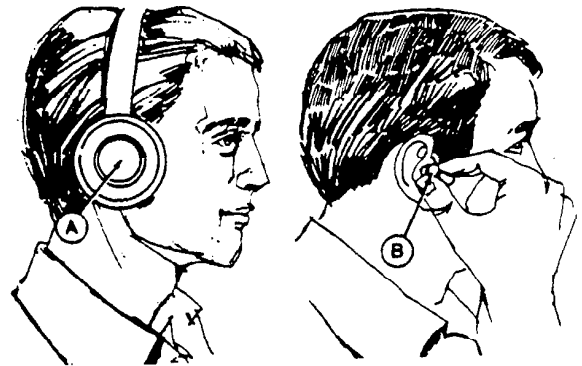

X7662

Prolonged exposure to loud noise can cause impairment or loss of hearing. Wear a suitable hearing protective device such as earmuffs (A) or earplugs (B) to protect against objectionable or uncomfortable loud noise.

If your machine is equipped with a starting fluid starting aid, remember starting fluid is highly flammable. **DO NOT** incinerate or puncture a starting fluid container. **DO NOT** store a starting fluid container in a high-temperature area.



T84926

If your machine has a roll-over protective structure, **USE A SEAT BELT.**

If your machine does not have a roll-over protective structure, **DO NOT USE A SEAT BELT.**

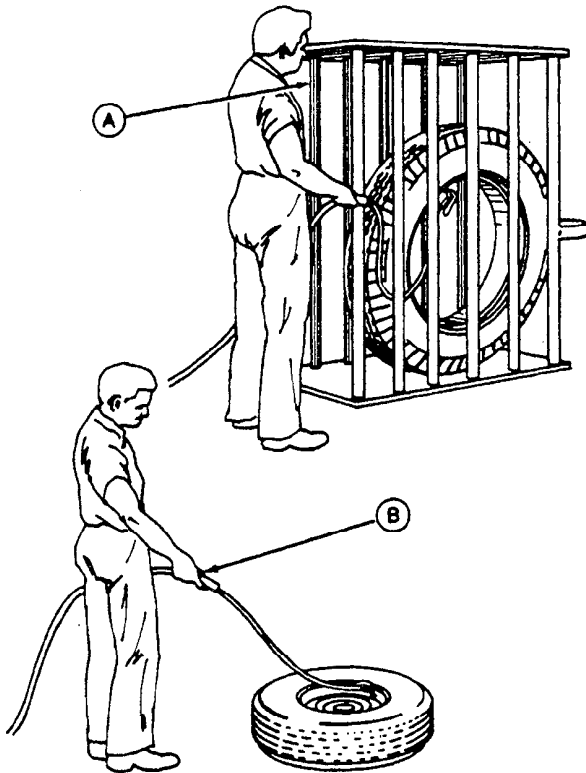

Failure to follow proper procedures when mounting a tire on a wheel or rim can produce an explosion which may result in serious injury or death. Do not attempt to mount a tire unless you have the proper equipment and experience to perform the job. Have it done by your John Deere dealer or a qualified tire repair service.

Detailed tire mounting instructions, including necessary safety precautions, are contained in John Deere Fundamentals of Service (FOS) Manual 55, Tires and Tracks, available through your John Deere dealer. Such information also available from the Rubber Manufacturers Association and from tire manufacturers.

A—Use a Safety Cage if Available
B—DO NOT Stand Over Tire. Use a Clip-On Chuck and Extension Hose.

TS0123

Group III GENERAL SPECIFICATIONS

(Specifications and design subject to change without notice. Wherever applicable, specifications are in accordance with ICED and SAE Standards. Except where otherwise noted, these specifications are based on a unit equipped with 26.5-25, 24 ply rating tires, ROPS canopy, full fuel tank, 175 lb. (80 kg) operator, and all standard equipment.)

Capacity (SAE heaped):

Volume 16 cu. yd. (12.23 m³)
Total weight of payload @ 2500 lb./yd.³
(1483 kg/m³) 40,000 lb. (18 144 kg)

Power (@ 2100 engine rpm):

	SAE	DIN
Gross	270 hp (201 kW*)	
Net	250 hp (186 kW)	253.5 PS

Net engine flywheel power is for an engine equipped with fan, air cleaner, water pump, lubricating oil pump, fuel pump, alternator, and muffler. Gross engine power is without fan. Flywheel power ratings are under SAE standard conditions of 500 ft. altitude and 85°F temperature and DIN 70 020 standard conditions of 760 mm Hg barometer (sea level) and 20°C temperature. Engine maintains rated horsepower up to 7500 feet (2 290 m) altitude.

**In the International System of Units (SI), power is expressed in kilowatts (kW).*

Engine: John Deere turbocharged and intercooled diesel, 6-cylinder, 4-stroke cycle

Bore and stroke 5.12x5 in. (130x127 mm)
Piston displacement 619 cu. in. (10 144 cm³)
Compression ratio 15.2 to 1
Maximum torque @
1400 rpm 813 lb-ft (1102 N·m) (112.4 kg-m)
NACC or AMA (U.S. Tax) horsepower 62.9
Main bearings 7
Lubrication Pressure system w/full-flow filter
Cooling Pressurized w/thermostat and fixed bypass
Fan Suction
Air cleaner w/restriction indicator Dry
Electrical system 24 volt w/alternator
Batteries (two 12 volt) Reserve capacity:
310 minutes

Transmission: Planetary Power-Shift, 6 speeds forward, 1 reverse. Micro-processor controlled, fully automatic shift with complete modulation

Torque Converter: Two phase, single stage with a 2.84 to 1 multiplication ratio, free-wheeling stator lock-up clutch and automatic control

Differential Lock Foot-operated, hydraulically actuated

Drive Axle . . Differential drive; over-all ratio 22.22 to 1; planetary final drives with 4.4 gpm (0.28 L/s) for lubrication and differential lock actuation

Brakes: Hydraulic, power actuated. An accumulator provides several brake applications after engine is stopped.

Tractor Wet-disk between differential and planetaries. No adjustment needed.

Scraper . . Expanding shoe, self-adjusting in wheels.

Parking Manually controlled, mechanical, on axle input shaft.

Power Steering: Position-responsive
Articulated frame hydraulically actuated by dual cylinders.

Turning circle
(180 deg. turn) 32 ft. 9.9 in. (10.0 m)

Articulation 180 deg.

Tractor Oscillation (total) 40 deg.

Hydraulic System:

Main tractor system: Closed-center
System pressure 2350 psi (16 203 kPa)
(165.2 kg/cm²)

Operates steering, brakes, and all scraper functions except elevator drive.

Main pump . . . Variable displacement, constant pressure; delivers 63 gpm (3.97 L/s) @ 2100 engine rpm.

Main charge pump delivers 20.3 gpm (1.28 L/s) @ 2100 engine rpm.

Elevator system . . . Engine-driven, 5.43 cu. in. (89 cm³) variable displacement, reversible hydrostatic pump delivers 53.5 gpm (3.38 L/s) @ 2100 engine rpm.

System pressure 5000 psi (34 475 kPa)
(351 kg/cm²)

Filtration . . . All systems are protected by replaceable filters.

Main hydraulic system 10-micron filters

Elevator system 10-micron filters

Transmission 10-micron filters

Hydraulic Cylinders:	Bore	Stroke
Lift (2)	5 in. (127 mm)	20 in. (508 mm)
Sliding floor (1)	5.25 in. (133 mm)	38.8 in. (986 mm)
Ejector gate (2)	3 in. (76 mm)	49.0 in. (1.24 m)
Steering (2)	4 in. (102 mm)	25.9 in. (658 mm)
Piston rods	Ground, heat-treated, chrome-plated, polished	
Lift and steering cylinders	2 in. (51 mm) dia.	
Sliding floor cylinder	2.5 in. (64 mm) dia.	
Ejector gate cylinders	1.75 in. (44 mm) dia.	

Elevator: Reversible, hydrostatic drive with heavy-duty planetary reduction
 Number of flights 23
 Spacing of flights 12.52 in. (318 mm)
 Width of flights 6 ft. 6 in. (1.98 m)
 Speed (@ 2100 engine rpm) . . 0-240 fpm (73 m/min)
 Length (top to bottom) 12 ft. (3.66 m)

Bowl: . . . Heavy-gauge steel with reinforcing and box construction. Sliding floor rides on heat-treated rails. Cutting edge retracts. Independent axles are vertically adjustable.

Cutting Edge: . . . 8 ft. 9.9 in. (2.69 m) wide; 3 sections, reversible and replaceable, high-carbon steel. Each section is adjustable vertically 2 in. (51 mm).
 Center section . . . 1x13x77.9 in. (25x330x1979 mm)
 End sections 1x13x14 in. (25x330x356 mm)

Tires:
 26.5-29, steel-cord radials
 26.5-25, 24 ply rating, E2
 26.5-29, 26 ply rating, E3
 26.5-29, steel-cord radials

Capacities:	U.S.	IMP.	Liters
Cooling system	15 gal.	12.5 gal.	56.8
Fuel tank	113 gal.	94.4 gal.	429
Engine lubrication, including filter	31 qt.	25.8 qt.	29.3
Transmission case and filter	19 gal.	15.8 gal.	71.9
Differential case	7.5 gal.	6.2 gal.	28.4
Hydraulic reservoir	24 gal.	20.0 gal.	90.8
Elevator gear case	8 qt.	6.7 qt.	7.6

Weight Distribution:	lb.	kg
Empty: Drive axle	32,050	14 538
Scraper axle	17,139	7 774
Total	49,189	22 312
Loaded: Drive axle	44,400	20 140
Scraper axle	44,789	20 316
Total	89,189	40 456

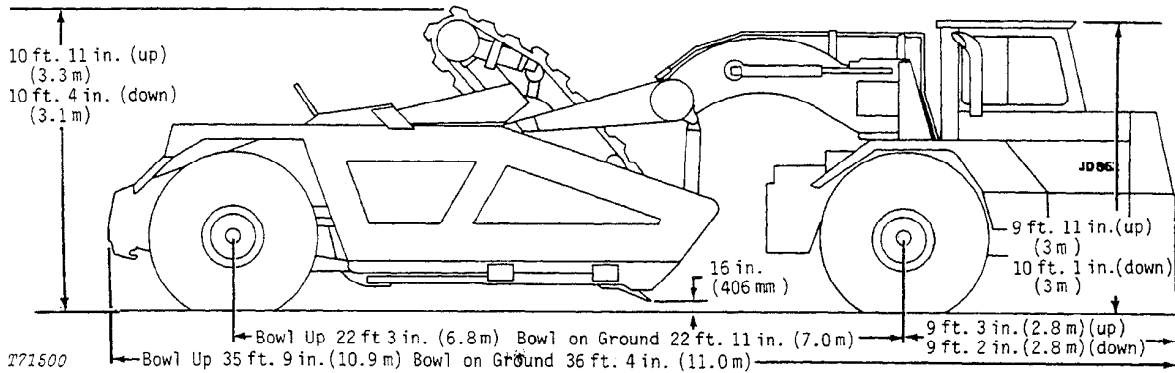
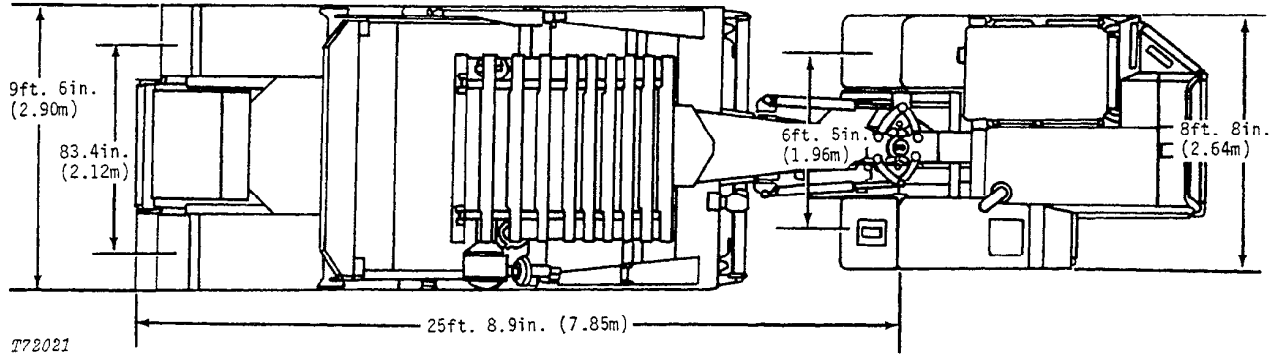

JD862 SCRAPER DIMENSIONS



CUSTOMARY HARDWARE TORQUE

NOTE: Torques shown are for dry (no lubrication on threads) hardware.

NOTE: Torque wrench tolerance is \pm 10 percent of specified torque.

Cap Screw Size-Inches	Customary Hardware					
	 Grade B		 Grade D		 Grade F	
	lb-ft.	(N-m)	lb-ft.	(N-m)	lb-ft.	(N-m)
1/4	10	(14)	14	(19)	30	(41)
5/16	20	(27)	35	(47)	50	(68)
3/8	35	(47)	55	(75)	80	(108)
7/16	55	(75)	85	(115)	120	(163)
1/2	75	(102)	130	(176)	175	(237)
9/16	105	(142)	170	(230)	240	(325)
5/8	185	(251)	300	(407)	425	(576)
3/4	160	(217)	445	(603)	685	(929)
7/8	250	(339)	670	(908)	1030	(1396)
1	330	(447)	910	(1234)	1460	(1979)
1-1/8	480	(651)	1250	(1695)	2060	(2793)

Check all cap screws and nuts, which can be easily reached, to be sure they are tight. If hardware is loose, tighten it to torque shown on chart above unless a special torque is specified.

TS859AC

METRIC HARDWARE TORQUE

NOTE: Torques shown are for hardware with SAE30W oil on threads.

NOTE: Torque wrench tolerance is ± 10 percent of specified torque.

Metric Standard Thread

Thread	8.8		10.9		12.9	
	N·m	(lb-ft)	N·m	(lb-ft)	N·m	(lb-ft)
M5	5.9	(4.4)	7.9	(5.8)	9.8	(7.2)
M6	9.8	(7.2)	13.8	(10.2)	16.7	(12.3)
M8	24.6	(18.1)	34.4	(25.4)	40.2	(29.6)
M10	48.1	(35.5)	67.8	(50.0)	81.5	(60.1)
M12	84.4	(62.2)	118.0	(87.0)	142.0	(105.0)
M14	133.0	(98.0)	187.0	(138.0)	226.0	(167.0)
M16	206.0	(152.0)	290.0	(214.0)	348.0	(257.0)
M18	285.0	(210.0)	398.0	(294.0)	476.0	(351.0)
M20	402.0	(296.0)	570.0	(420.0)	677.0	(499.0)
M22	540.0	(398.0)	765.0	(564.0)	914.0	(674.0)
M24	697.0	(514.0)	980.0	(723.0)	1180.0	(870.0)

Metric Fine Thread

Thread	8.8		10.9		12.9	
	N·m	(lb-ft)	N·m	(lb-ft)	N·m	(lb-ft)
M8 x 1	26.5	(19.5)	37.3	(27.5)	44.2	(32.6)
M10 x 1	47.1	(34.7)	68.8	(50.7)	81.5	(60.1)
M12 x 1.5	88.4	(65.2)	123.0	(91.0)	147.0	(108.0)
M14 x 1.5	147.0	(108.0)	206.0	(152.0)	246.0	(181.0)
M16 x 1.5	221.0	(163.0)	309.0	(228.0)	373.0	(275.0)
M18 x 1.5	319.0	(235.0)	451.0	(333.0)	540.0	(398.0)
M20 x 1.5	451.0	(333.0)	628.0	(463.0)	755.0	(557.0)
M22 x 1.5	559.0	(442.0)	845.0	(623.0)	1030.0	(760.0)
M24 x 2	765.0	(564.0)	1080.0	(796.0)	1275.0	(940.0)
M26 x 2	1130.0	(833.0)	1570.0	(1158.0)	1915.0	(1412.0)

NOTE: Numbers are used to mark heads of metric hardware.

8.8 Head - Tempered steel, high strength bolts and cap screws.

10.9 Head - Tempered steel, extra-high strength bolts and cap screws

12.9 Head - Tempered steel, extra-extra-high strength bolts and cap screws.

Litho in U.S.A.

TUBE AND HOSE FITTING, 37° FLARE AND 30° CONE SEAT CONNECTOR SERVICE RECOMMENDATIONS

1. Inspect the flare and the flare seat. They must be free of dirt and defects. If repeated leaks occur, inspect for defects with a magnifying glass. If burrs and raised nicks on the connector body cannot be removed with a slip stone, replace the connector.

2. Defects in the tube flare cannot be repaired. Replace the tube. Overtightening a defective flared fitting will not stop leaks.

3. As a field repair, a ductile truncated cone shaped washer can be used between the tube flare and connector body. These washers are soft enough to fill defects in the seat and flare. They will also seal the connection. Ductile washers are available from industrial supply houses.

4. Align the tube with the fitting before attempting to start the nut. Failure to do so can cause a deformed flare and subsequent leaks. Install hoses without twists. A twisted hose attempts to straighten out when pressure is applied. This exerts a torque on the connection, eventually causing failure.

5. Lubricate the connection with hydraulic fluid, petroleum jelly or soap. Tighten the swivel nut by hand until it is snug.

6. Mark a line across the nut and connector body. This line will serve as a visual indicator as to whether the nut has been tightened and by how much.

7. Using two wrenches, one on the connector body and a torque wrench on the nut, tighten the nut to the torque value as shown in the chart. In the case of a hose, it may be necessary to use three wrenches to prevent twisting.

TUBE AND HOSE FITTING, 37° FLARE AND 30° CONE SEAT CONNECTOR TORQUE

Thread Size	N·m	Torque ¹ (lb-ft)	New ² Number of Flats	Used ³ Number of Flats
3/8-24 UNF	8	(6)	2-1/2	1
7/16-20 UNF	12	(9)	2-1/2	1
1/2-20 UNF	16	(12)	2-1/2	1
9/16-18 UNF	24	(18)	2	1
3/4-16 UNF	46	(34)	2	1
7/8-14 UNF	62	(46)	1-1/2	1
1-1/16-12 UN	102	(75)	1	3/4
1-3/16-12 UN	122	(90)	1	3/4
1-5/16-12 UN	142	(105)	3/4	3/4
1-5/8-12 UN	190	(140)	3/4	3/4
1-7/8-12 UN	217	(160)	1/2	1/2

1. Tolerance of $\pm 10\%$.

2. To be used if a torque wrench cannot be used. After tightening fitting by hand, put a mark across the fittings, then tighten fitting the number of flats shown.

3. Flare connection seal by deforming or squeezing the tube between the nut and the connector. More deformation is possible with new parts than with old. Therefore, if a torque wrench is not used for re-assembly, the values in this column must be used to prevent damage.

T5859AE

O-RING BOSS FITTING SERVICE RECOMMENDATIONS

1. Inspect boss O-ring seat. It must be free of dirt and defects. If repeated leaks occur, inspect for defects with a magnifying glass. Some raised defects can be removed with a slip stone.

Occasionally a lower durometer O-ring will seal against a rough seat. If neither of these solutions work, the component must be replaced.

2. Put hydraulic oil, petroleum jelly or soap on the O-ring. Put a thimble over the threads to protect O-ring from nicks. Slide O-ring over the thimble and into the turned down section of fitting.

For angle fittings, loosen special nut and push special washer against threads so O-ring can be installed into the turned down section of fitting.

3. Turn fitting into the boss by hand until special washer or washer face (straight fitting) contacts boss face and O-ring is squeezed into its seat.

4. To position angle fittings, turn the fitting counter-clockwise a maximum of one turn.

5. Tighten straight fittings to the torque value shown in chart. For angle fittings, tighten the special nut to valve shown in the chart while holding body of fitting with a wrench.

STRAIGHT FITTING OR SPECIAL NUT TORQUE (1)

Thread Size	Torque ¹		Number Of Flats ²
	N·m	(lb-ft)	
3/8-24 UNF	8	(6)	2
7/16-20 UNF	12	(9)	2
1/2-20 UNF	16	(12)	2
9/16-18 UNF	24	(18)	2
3/4-16 UNF	46	(34)	2
7/8-14 UNF	62	(46)	1-1/2
1-1/16-12 UNF	102	(75)	1
1-3/16-12 UNF	122	(90)	1
1-5/16-12 UNF	142	(105)	3/4
1-5/8-12 UNF	190	(140)	3/4
1-7/8-12 UNF	217	(160)	1/2

1. Tolerance \pm 10%.

2. To be used if a torque wrench cannot be used. After tightening fitting by hand, put a mark on nut and boss; then tighten special nut or straight fitting the number of flats shown.

T5859AG

SAE FOUR BOLT FLANGE FITTING SERVICE RECOMMENDATIONS

1. Inspect the sealing surfaces for nicks or scratches, roughness or out-of-flat condition. Scratches cause leaks. Roughness causes seal wear. Out-of-flat causes seal extrusion. If these defects cannot be polished out, replace the component.

2. Install the correct O-ring (and backup washer if required) into the groove using petroleum jelly to hold it in place.

3. For split flange; loosely assemble split flange halves, being sure that the split is centrally located and perpendicular to the port. Hand tighten cap screws to hold parts in place. Do not pinch O-ring.

4. For single piece flange; put hydraulic line in the center of the flange and install four cap screws. With the flange centrally located on the port, hand tighten cap screws to hold it in place. Do not pinch O-ring.

5. For both single piece flange and split flange, be sure the components are properly positioned and cap screws are hand tight. Tighten one cap screw, then tighten the diagonally opposite cap screw. Tighten the two remaining cap screws. Tighten all cap screws within the specified limits shown in the chart.

DO NOT use air wrenches. DO NOT tighten one cap screw fully before tightening the others. DO NOT over-tighten.

SAE FOUR BOLT FLANGE FITTING TORQUE

Nominal Flange Size	Cap Screw Size ¹	Torque ²			
		N·m		(lb-ft)	
		Min.	Max.	Min.	Max.
1/2	5/16 - 18 UNC	20	31	(15)	(23)
3/4	3/8 - 16 UNC	28	54	(21)	(40)
1	3/8 - 16 UNC	37	54	(27)	(40)
1-1/4	7/16 - 14 UNC	47	85	(35)	(63)
1-1/2	1/2 - 13 UNC	62	131	(46)	(97)
2	1/2 - 13 UNC	73	131	(54)	(97)
2-1/2	1/2 - 13 UNC	107	131	(79)	(97)
3	5/8 - 11 UNC	158	264	(117)	(195)
3-1/2	5/8 - 11 UNC	158	264	(117)	(195)
4	5/8 - 11 UNC	158	264	(117)	(195)
5	5/8 - 11 UNC	158	264	(117)	(195)

1. SAE Grade 5 or better cap screws with plated hardware.

2. Tolerance \pm 10%. The torques given are enough for the given size connection with the recommended working pressure. Torques can be increased to the maximum shown for each cap screw size if desired. Increasing cap screw torque beyond this maximum will result in flange and cap screw bending and connection failures.

TS89AF

O-RING FACE SEAL FITTING SERVICE RECOMMENDATIONS

1. Inspect the sealing surfaces for nicks or scratches, roughness, or out-of-flat condition. Scratches cause leaks. Roughness causes seal wear. Out-of-flat causes seal extrusion. If these defects cannot be polished out, replace the component.

2. Lubricate O-ring and male threads with petroleum jelly.

For O-ring face seal fittings, push O-ring into groove.

For O-ring boss fittings, put a thimble over the threads to protect O-ring from nicks. Slide O-ring over the thimble and into the turned down section of fitting.

For angle fittings, loosen special nut and push special washer against threads so O-ring can be installed into the turned down section of fitting.

3. Install fitting and hand tighten until snug. To position angle fittings, turn fitting counterclockwise a maximum of one turn.

4. Tighten fitting for nut to the torque value shown in chart. Use one wrench to hold connector body and another wrench to tighten nut. When tightening a fitting on a hose, it may be necessary to use three wrenches to prevent twisting hose; one on the connector body, one on the nut, and one on the body of the hose fitting.

O-RING FACE SEAL FITTING TORQUE (1)

Nominal			Thread Size in.	O-Ring Face Seal End				O-Ring Boss End		
Tube mm	O.D. in.	Dash Size		Swivel Nut Torque		Bulkhead Nut Torque		Thread Size in.	Straight Fitting or Jam Nut Torque	
				N·m	lb-ft	N·m	lb-ft		N·m	lb-ft
4.76	0.188	-3	— — —	—	—	—	—	3/8-24	8	6
6.35	0.250	-4	9/16-18	16	12	5.0	3.5	7/16-20	12	9
7.94	0.312	-5	— — —	—	—	—	—	1/2-20	16	12
9.52	0.375	-6	11/16-16	24	18	9.0	6.5	9/16-18	24	18
12.70	0.500	-8	13/16-16	50	37	17.0	12.5	3/4-16	46	34
15.88	0.625	-10	1-14	69	51	17.0	12.5	7/8-14	62	46
19.05	0.750	-12	1-3/16-12	102	75	17.0	12.5	1-1/16-12	102	75
22.22	0.875	-14	1-3/16-12	102	75	17.0	12.5	1-3/16-12	122	90
25.40	1.000	-16	1-7/16-12	142	105	17.0	12.5	1-5/16-12	142	105
31.75	1.250	-20	1-11/16-12	190	140	17.0	12.5	1-5/8-12	190	140
38.10	1.500	-24	2-12	217	160	17.0	12.5	1-7/8-12	217	160

1. Tolerance: ± 15-20%.

Group IV PREDELIVERY, DELIVERY, AND AFTER-SALE SERVICES

TEMPORARY STORAGE

After receiving your scraper from the factory and before putting the machine into temporary storage, make the following checks and services:

1. Check the battery connections. Turn key switch on. Check the voltmeter. Charge the battery, if necessary.
2. Check the level of the coolant in the radiator. The coolant must be seen in the sight glass when the engine is cold.
3. Fill the fuel tank.
4. Check the crankcase oil level. Oil must be between marks on the dipstick after the engine has been stopped for 10 minutes.
5. Release hydraulic pressure by lowering the bowl, stopping the engine, and moving the steering wheel until the machine does not move.

PREDELIVERY SERVICE

The service technician must carefully check and service the machine before the dealer delivers it to the customer. When the customer receives a machine that is correctly prepared, the customer is well-satisfied. For these reasons, correct predelivery service is very important to the dealer and the customer.

Use the following list when getting a unit ready for delivery to the customer.

1. Cab Equipment

Check the operation of the following equipment: seat belt, right (R.H.) window, vandal cover and locks, door, steering wheel, dome light, auxiliary heater. Make adjustments, if necessary.

Cab equipment checked Yes No

2. Seat

Check the operation of the seat.

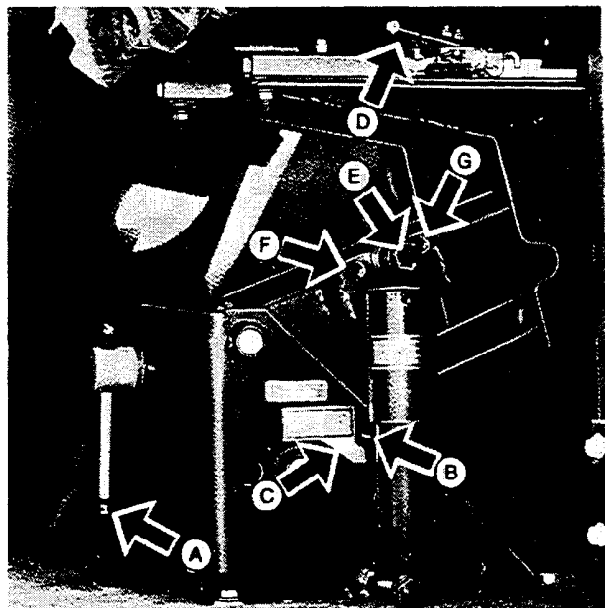

T84922

- | | |
|--|-------------|
| A—Weight Adjustment Lever | E—Cap Screw |
| B—Pointer | F—Soft Ride |
| C—Ride Zone | G—Firm Ride |
| D—Forward or Rearward Adjustment Lever | |

Fig. 1-Seat

Adjustment for Weight

While seated, turn lever A clockwise to lower the seat. Turn the lever counterclockwise to raise the seat.

Change the height so the pointer (B) is in the ride zone (C).

**Numbers in parenthesis are same as item numbers on the periodic maintenance chart on your scraper.*

Adjustment Forward or Rearward

While seated, move lever D to the left (L.H.). Slide the seat to the desired position. Release the lever.

Adjustment for Ride

Install the shock absorber cap screw (E) in the front hole (F) for a soft ride, or in the rear hole (G) for a firm ride.

Up-Latch Lever

While seated, pivot lever E rearward before standing to lock the seat in position.

The lever will automatically release when you sit.

Seat operation checked Yes No

3. Gauges, Switches, and Indicator Lights

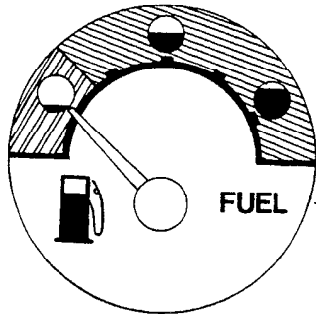

T40227N

Fig. 2-Fuel Level Gauge

Add a small amount of fuel to the fuel tank. Check the action of the fuel gauge.

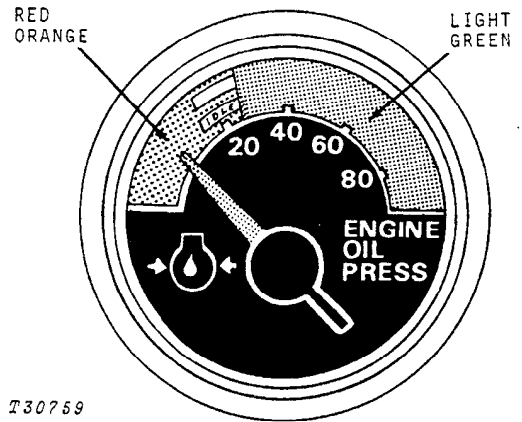

T30759

Fig. 3-Engine Oil Pressure Gauge

Normal operating range is 170-550 kPa (1.7-5.5 bar) (25-80 psi).

If the indicator hand goes into the red-orange zone, stop the scraper. Check the engine oil level. If the oil level is not low, check for restrictions in the oil lines or wrong viscosity oil.

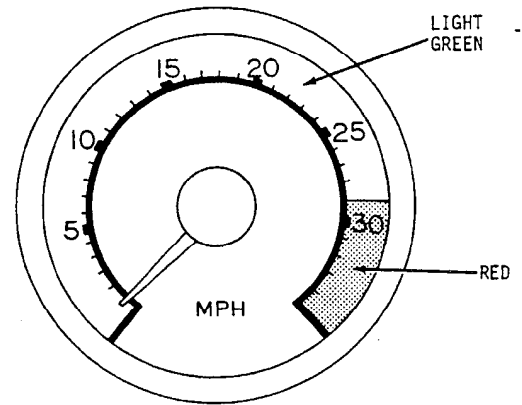

T55469N

Fig. 4-Speedometer

The speedometer shows scraper speeds from 0 to 55 km/h (0 to 34 mph). Red background at 46.7 km/h (29 mph) and over shows overspeed.

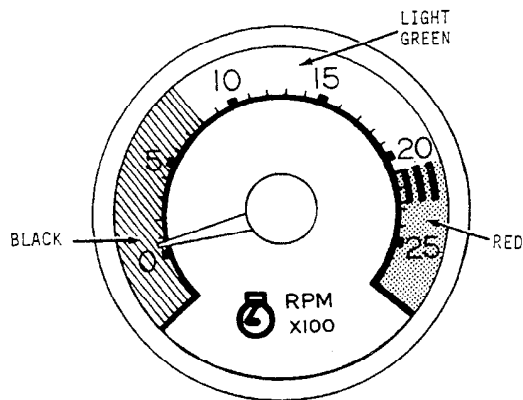

T72037

Fig. 5-Tachometer

The tachometer shows engine rpm from 0 to 2500 rpm. Normal operating range is 925 to 2300 rpm.

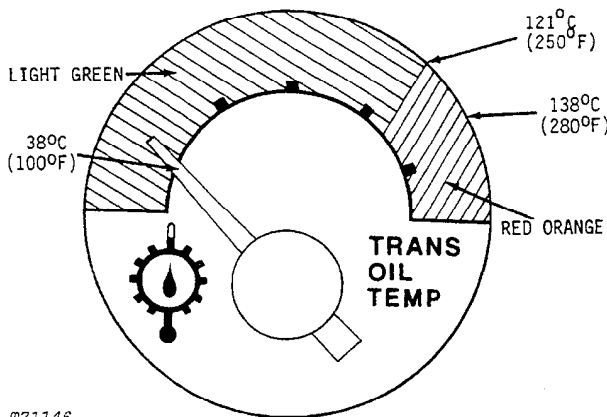

T71146

Fig. 6-Transmission Oil Temperature Gauge

The light green zone shows the normal operating range, 38-121°C (100-250°F).

If the indicator hand enters the red zone, operate in a lower gear. If the hand remains in the red zone, check the transmission oil level.

If these possible solutions do not lower the oil temperature, do not operate the scraper.

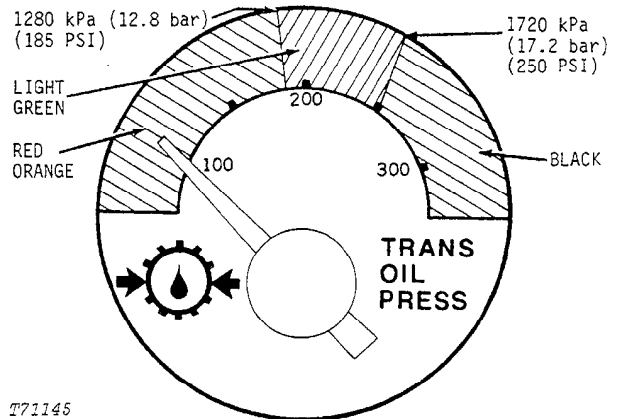

T71145

Fig. 7-Transmission Oil Pressure Gauge

The light green zone shows the normal operating range.

IMPORTANT: If the indicator hand is in either red-orange zone or black zone, stop the scraper and find the cause.

NOTE: During cold weather, the gauge will normally read high for a short time after the engine starts.

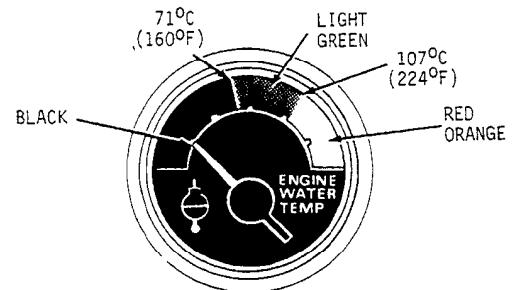

T71147

Fig. 8-Engine Coolant Temperature Gauge

The light green zone shows the normal operating temperatures, 71-107°C (160-224°F).

IMPORTANT: If the indicator hand goes into the RED-ORANGE ZONE, stop the engine and find the cause.

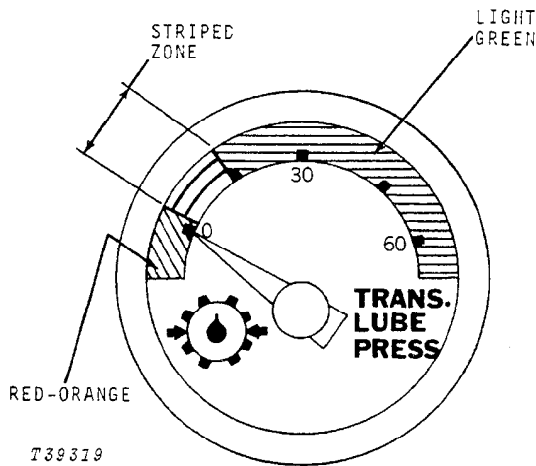

Fig. 9-Transmission Lube Pressure Gauge

When engine is running at slow idle, the gauge must show in striped zone. When operating under constant heavy loads, the gauge must show in the light green zone.

DO NOT operate the scraper when the needle is in the red-orange zone. If needle is in this zone, stop the scraper. Check transmission filter. If filter is not clogged and needle is still in red-orange zone, see your John Deere dealer.

NOTE: Transmission lube pressure will vary with engine speed and oil temperature.

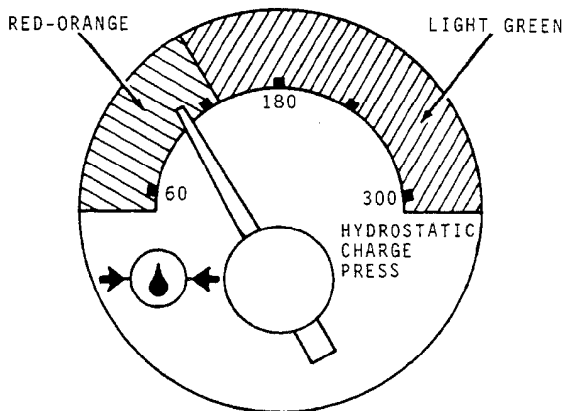

Fig. 10-Hydrostatic Charge Pressure Gauge

Normal operating range is in light green zone. If gauge registers in red-orange zone, stop the scraper. Find the cause.

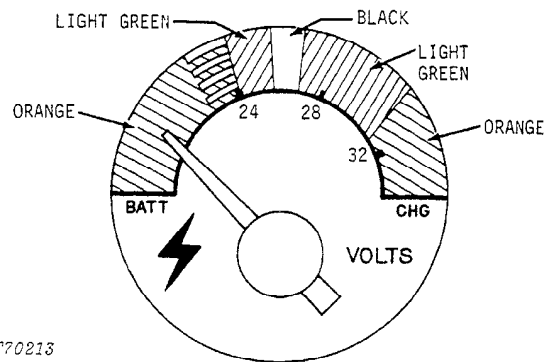

Fig. 11-Voltmeter

Normal operating range is indicated by the right (R.H.) green zone.

If the indicator hand is not in this green zone, troubleshoot the electrical system.

Check the operation of the switches.

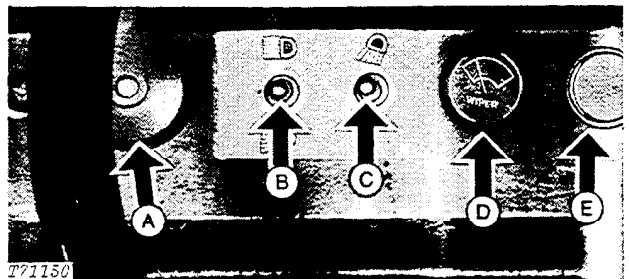

Fig. 12-Switches

A - Turn Signal Switch - Lift switch to flash right (R.H.) turn signal. Push down switch to first position to flash left (L.H.) turn signal. Push switch all the way down to flash all four turn signal lights.

B - Headlight Switch - Activate switch upward to turn on four headlights and taillights. Push switch downward to turn on two low beam headlights and tail lights.

C - Work Light Switch - Activate switch to turn on two rear work lights.

D - Wiper Switch - Turn switch clockwise for low or high speed wiper action.

E - Starting Aid Button - Remove starting fluid can from engine. Push starting aid button. Listen for solenoid click.

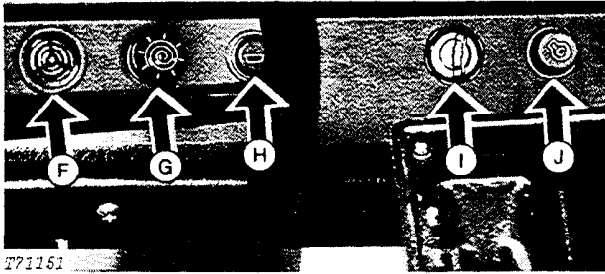

Fig. 13-Switches

- F - Buzzer - Read information on indicator lights below.
- G - Cigar Lighter - Push to activate.
- H - Horn Switch - Push the button to sound dual horns.
- I - Ignition Switch - Turn the key clockwise to turn the switch on. No other switches or gauges work unless the ignition switch is on.
- J - Starter Switch - Push the button to start the engine.

Check operation of indicator lights.

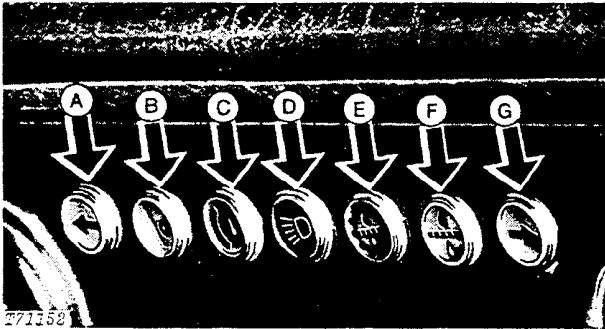

Fig. 14-Indicator Lights

- A - Left (L.H.) Turn Indicator Light - Flashes for left turn and emergency flashing.
- B - Parking Brake Indicator Light - Glows when parking brake is engaged and key switch is on. Buzzer will sound at intervals.
- C - Brake Pressure Indicator Light - Glows when pressure in system falls below 10,500 kPa (105 bar) (1525 psi). Buzzer will sound at intervals. Light may glow briefly after engine starts until pressure goes above 10,500 kPa (105 bar) (1525 psi). If this light glows when scraper is operating, stop scraper and find cause.

- D - High Beam Indicator Light - Glows blue when bright headlights are on.
- E - Transmission Filter Restriction Indicator Light - Glows when transmission filter is plugged. Also glows during warm-up when oil is cold. Buzzer will sound at intervals.
- F - Hydraulic Filter Restriction Indicator Light - Glows when hydraulic filter is plugged. Also glows during warm-up when oil is cold. Buzzer will sound at intervals.
- G - Right Turn Indicator Light - Flashes for right (R.H.) turn and emergency flashing.

Gauges, switches, and indicator
lights checked

Yes No

4. Transmission

Check the operation of the transmission.

Controls

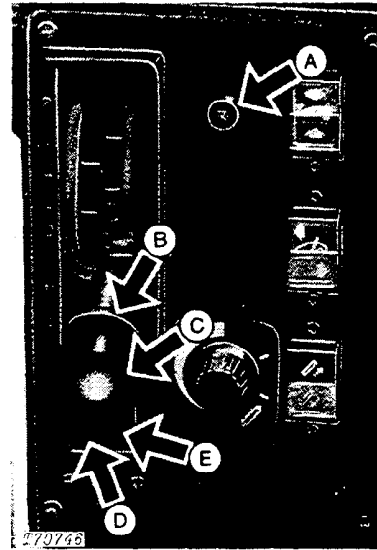

Fig. 15-Transmission Controls

- A - Transmission Indicator Light - If light glows amber, transmission is in automatic mode. If light is off, transmission is in manual mode.

- B - Neutral Lock - Lift sleeve before moving shift lever from neutral into reverse or first gear. Lift sleeve before moving lever from first gear to neutral. Move lever from reverse to neutral without lifting sleeve.
- C - Gear Shift Lever - Move lever to desired gear.
- D - Gear Indicator Light - Shows the gear the transmission is in. Also shows neutral ("0") and reverse (- [minus sign]). When shift lever is in neutral, the light flashes available gears if transmission electrical system is not working correctly.
- E - Lockup Indicator Light - Light shows "L" when the lockup clutch locks a gear in direct drive. Light also flashes if transmission lockup electrical system is not working correctly.

Check the operation of the transmission in the three shift patterns in automatic mode.

Transporting Shift Pattern

1. Move shift lever to 6th gear.

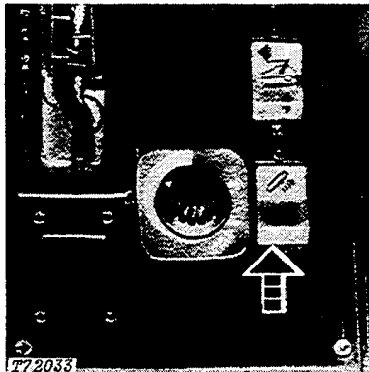

Fig. 16-Elevator Switch (Unloading)

2. Move the elevator switch to unload position (Fig. 16) or to neutral.
3. Push down accelerator.
4. Transmission should shift: 3TC*, 4TC, 4L+, 5TC, 5L, 6TC, 6L.

- * - Torque Converter Drive
- + - Lockup in Direct Drive

Loading Shift Pattern

1. Move shift lever to 6th gear.



Fig. 17-Elevator Switch (Loading)

2. Move the elevator switch to loading position.
3. Push down accelerator.
4. Transmission should shift: 1TC, 2TC, 3TC, 4TC, 5TC, 6TC.

Downshift Pattern

1. Drive the scraper in 6L gear.
2. Release the accelerator.
3. Transmission should shift: 6L, 5L, 4L, 3TC.

NOTE: To make a manual downshift, move the shift lever to the next lower gear. Do not manually downshift more than one gear lower at a time. Do not manually downshift above 1800 rpm.

Check the operation of the hold pedal.



Fig. 18-Hold Pedal

T72032

Use pedal only when transmission is in automatic mode.

Push down pedal. Transmission will operate as follows:

1. Will not shift out of gear it is in.
2. If in torque converter drive, transmission will stay in torque converter drive.
3. If in direct drive ("L" shows on lockup indicator), will stay in direct drive.

Diagnostics of Transmission Electrical System

1. If the transmission electrical system is not working correctly, the transmission will automatically shift to 4th gear. The gear indicator will flash "4". If 4th gear is not working, the transmission will shift to neutral and the indicator will flash "0".

NOTE: If lockup electrical system is not working, the lockup indicator will flash.

2. Move the shift lever to neutral.
3. The gear indicator will flash the gears that are working.
4. Switch to manual operation. Use only the working gears.

Transmission checked Yes No

5. Differential Lock Operation

Check the operation of the differential lock.

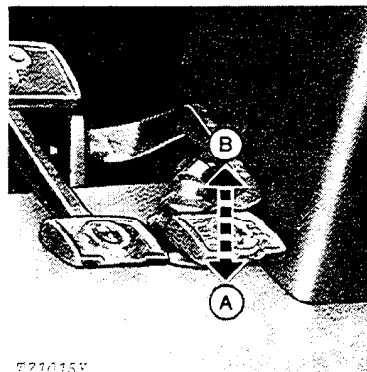

Fig. 19-Differential Lock Pedal

T71015Y

Start the engine. Engage the lock (A). Turn the steering wheel. If the lock is working correctly, steering resistance will be felt.

Differential lock checked Yes No

6. Engine Speed Linkage (30)

Check engine speeds when engine is at normal operating temperature.

IMPORTANT: Use only a calibrated tachometer to check engine speeds.

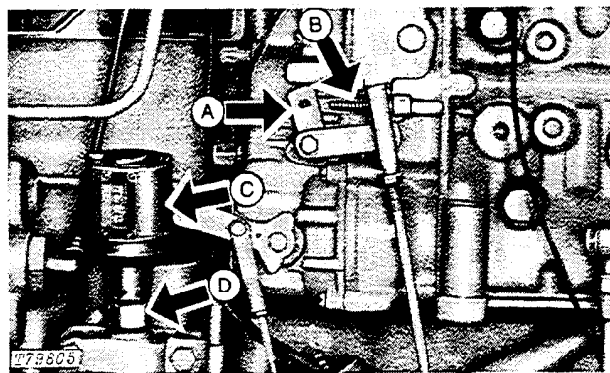

A—Control Lever
 B—High Speed Stop Screw
 C—Service Meter
 D—Tachometer Drive

Fig. 20-Checking Engine Speeds

Remove service meter (C). Connect calibrated tachometer to tachometer drive (D).

Slow idle must be 925 rpm. Fast idle must be 2325 rpm.

Check injection pump linkage for full travel. Control lever (A) must hit high speed stop screw (B).

If engine speeds need adjustment, see page I-IV-26.

Engine speeds checked Yes No

7. Accumulator Action (24)

Check brake accumulator action. Brakes should operate for several applications after engine is stopped. Brakes should be solid for a minimum of five applications.

Accumulator checked Yes No

8. Brakes

Check the operation of the hydraulic brakes.

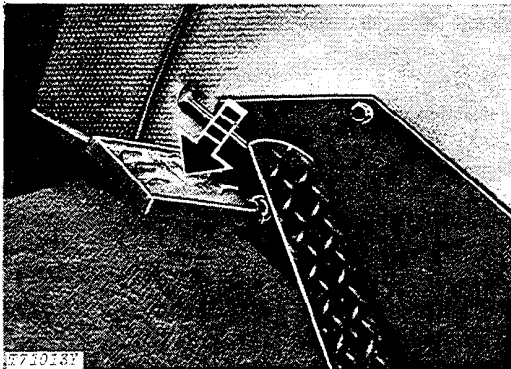

Fig. 21-Brake Pedal

Put the scraper in gear. Push down the brake pedal. Moderate pedal force must hold the machine in place.

Remove air from the brake system:

1. If moderate pedal force does not hold the machine in place.
2. If the pedal feels spongy.
3. If the pedal jumps back when it is pushed down.
4. If the pedal has too much travel.

See page I-IV-27 for the correct procedure.

Brakes checked Yes No

9. Parking Brake

Check action of parking brake.

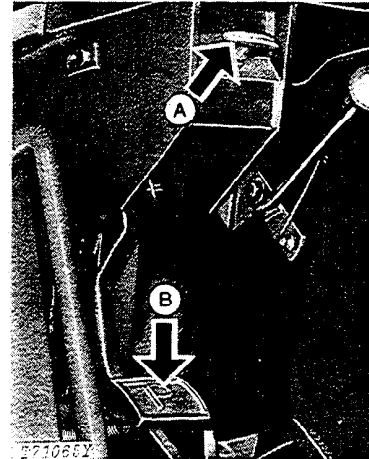

A—Release Handle

T71065Y
B—Parking Brake Pedal

Fig. 22-Parking Brake

Push down pedal (B) firmly. Pedal must not move more than four notches.

If adjustment is needed, see page I-IV-28.

Parking brake checked Yes No

10. Cycle Times

Check cycle times when the oil is warm and the engine at fast idle.

NOTE: Operate each hydraulic control until all air has been removed from the hydraulic system. Check all controls for freedom of movement and correct direction of travel before checking cycle times.

Use the following times as a guide. If cycle times are much different from those listed, trouble shoot the hydraulic system.

	Seconds
Elevator Speed (one complete revolution)	6.0 max.
Raise bowl	2.5 - 3.5
Lower bowl	3.5 - 4.0
Eject or Return Cycle	7.0 - 8.0
Steering (180° turn to right and left)	5.0 - 5.5 (Either Direction)

While checking cycle times, make a note of any equipment that is not working correctly.

When the engine is at slow idle (925 rpm), turn the steering wheel from stop to stop. Turn the steering wheel faster than normal to "force the turn". This will remove air from the steering system.

Cycle times checked	Yes	No
Malfunctions	_____	
_____	_____	

11. Air Conditioner

Check the air conditioner controls.

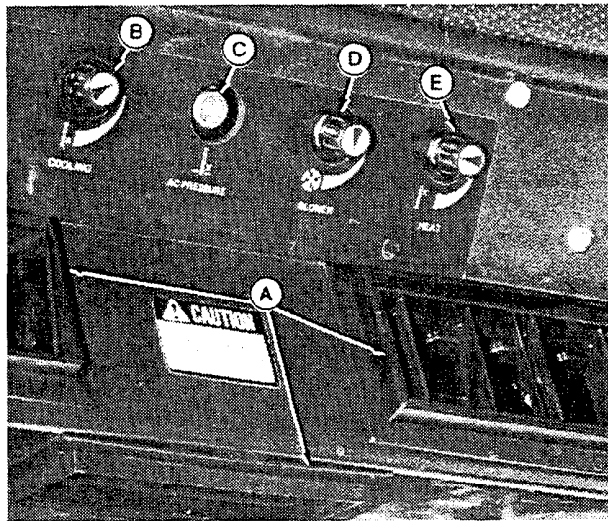

- A—Louvers
- B—Temperature Control Knob
- C—Refrigerant Pressure Indicator Light
- D—Blower Control Knob
- E—Heater Control Knob

Fig. 23-Air Conditioner Controls

NOTE: Air temperature must be 16°C (60°F) or higher.

1 - Turn the key switch ON. Operate the blower control knob (D) in all positions. Check the fan speeds and air volume from the louvers (A).

2 - Turn the key and blower switches ON. Turn the temperature control knob (B) clockwise toward maximum cooling. Listen for the click from the compressor clutch.

3 - Turn the heater valve (on the engine) clockwise to closed position.

4 - Turn the blower control knob clockwise to high speed. Turn the temperature control knob clockwise to maximum cooling. Run the engine at approximately 2000 rpm.

5 - After ten minutes check the sight glass on the receiver dryer for bubbles. The receiver dryer is behind the cab.

NOTE: Bubbles may be seen immediately after the compressor cycles ON. If bubbles are seen under any other condition, see Section 90, Group 9031.

6 - Check the temperature of air from the louvers. Hold a thermometer in the louver until you get the lowest reading.

When air temperature is above 27°C (80°F) the temperature of air from the louvers must be 14-17°C (25-30°F) lower.

When air temperature is below 27°C (80°F), the temperature of air from the louvers must be less than 10°C (50°F).

7 - If the unit does not operate correctly or if the pressure indicator light goes on, see Section 90, Group 9031.

Air conditioner checked	Yes	No
-------------------------	-----	----

12. Cab Recirculating air Filter (22)



Fig. 24-Recirculating Air Filter

Remove cover and filter.

If required, wash filter in warm, soapy water.

Rinse and dry.

13. Cab Fresh Air Filter (18)

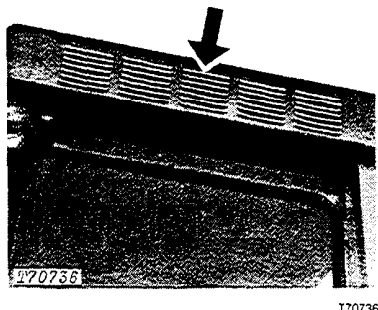

Fig. 25-Fresh Air Filter

Remove cover. Pull out filter.

To clean filter:

Tap filter on flat surface, dirty side down.

Blow low-pressure compressed air through filter opposite to normal air flow.

If required, wash filter in warm, soapy water. Rinse and dry.

14. Injection Pump Sediment Bowl and Filter (28)

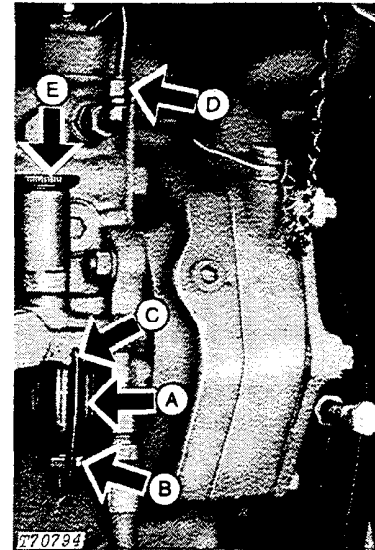

Fig. 26-Sediment Bowl and Filter

Check sediment bowl (A) for dirt and water.

If bowl needs cleaning, loosen nut (B).

Swing clip (C) away from bowl.

Remove bowl and filter.

Clean the bowl and filter.

Assemble all parts.

Be sure bowl gasket fits correctly.

Bleed the fuel system.

Bleeding the Fuel System:

Loosen fuel line (D).

Loosen the primer (E). Pump the primer until fuel free of bubbles flows from the fuel line.

Tighten the fuel line.

Push the primer down Tighten it by hand.

15. Water Separator (2)

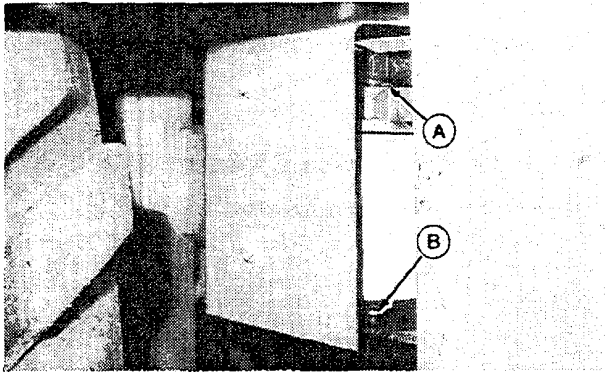

A—Vent Screw

B—Drain Petcock

Fig. 27-Water Separator

The water separator is located on bowl frame, under left rear fender.

Drain water and sediment when engine is cold.

Loosen drain petcock (B) shown.

Drain liquid until fuel flows from petcock.

Tighten drain petcock.

NOTE: If fuel does not flow, loosen vent screw (A).

16. Fuel Tank Sump (1)

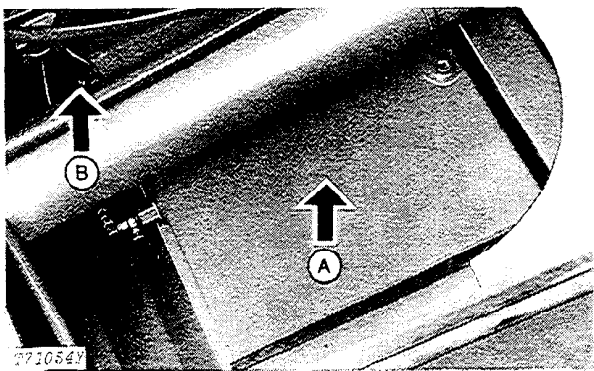

Fig. 28-Bottom of Fuel Tank

Open drain cock (B).

Drain water or sediment. Close drain cock.

NOTE: Fill fuel tank (A) after shutdown each day.

This view is of the bottom of the fuel tank.

17. Elevator Chain Sag (43)

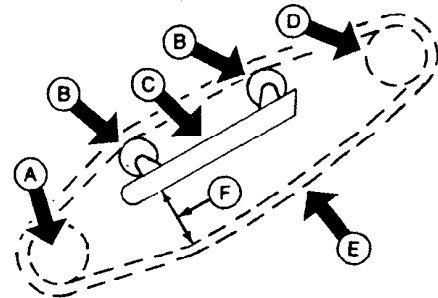

A—Lower Idler
B—Center Idler
C—Elevator Frame

D—Upper Idler
E—Chain
F—7 to 12 in. (18 to 31 cm)

Fig. 29-Elevator Chain

Measure chain sag between box section of elevator frame and top of chain sidebar at point of greatest sag.

Sag should be 7 to 12 in. (18 to 31 cm).

If sag is less than 7 in. (18 cm), chain will wear excessively.

If sag is more than 12 in. (31 cm), chain will jump sprocket teeth.

IMPORTANT: Chain sag should not vary more than 1 in. (25 mm) from side to side.

If adjustment is needed, see page I-IV-31.

18. Air Intake System (36)

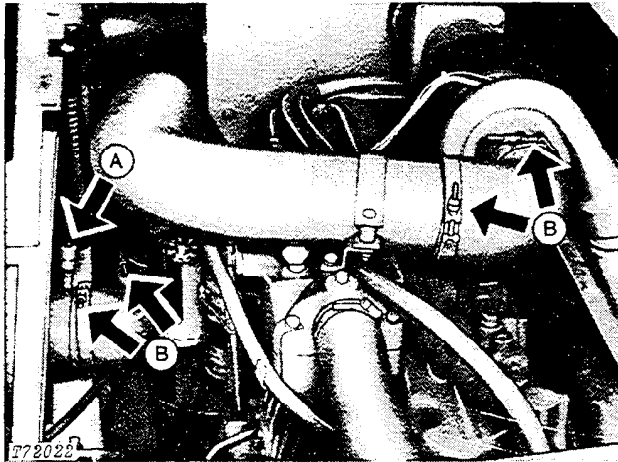

A—Restriction Indicator B—Clamps

Fig. 30—Air Intake System

Check the restriction indicator (A). If the red signal can be fully seen, check the air intake system for a restriction.

Inspect clamps (B) on hoses connecting the air cleaner and the engine. Tighten the hose clamps. Inspect the hoses for cracks.

Air intake system checked Yes No

19. Batteries

Check terminals and connections.

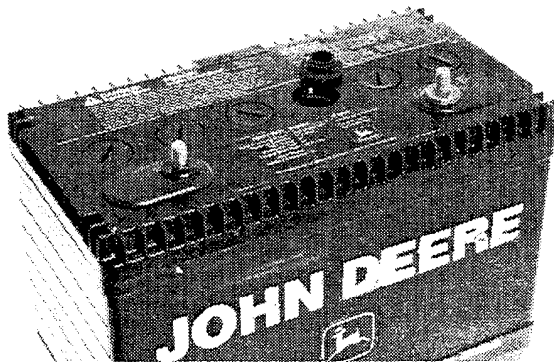

Fig. 31—Battery
(Calcium/Lead Battery Illustrated)

If terminals are corroded, clean them with a stiff brush.

Clean batteries with a damp cloth, if necessary.

Batteries checked Yes No

20. Engine Crankcase Oil Level (29)

Check the crankcase oil level.

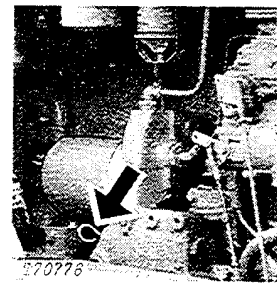

Fig. 32—Dipstick

Park scraper on level surface. Lower bowl to ground. Stop engine. Wait ten minutes for oil to drain into crankcase. Oil should be between marks on dipstick. If not, add oil specified on page I-V-4.

Crankcase oil level checked Yes No

21. Coolant Conditioner-Filter

Check coolant conditioner-filter valves.

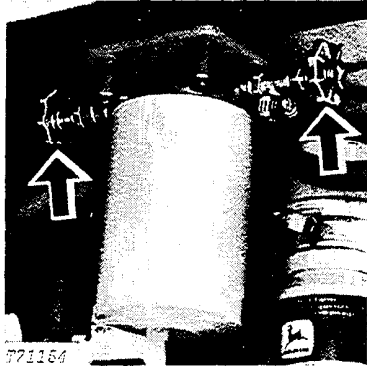

Fig. 33-Conditioner-Filter Valves

Valves must be open. Turn valves counterclockwise to open them.

Coolant conditioner-filter checked Yes No

22. Radiator Coolant Level (27)

Check coolant level.

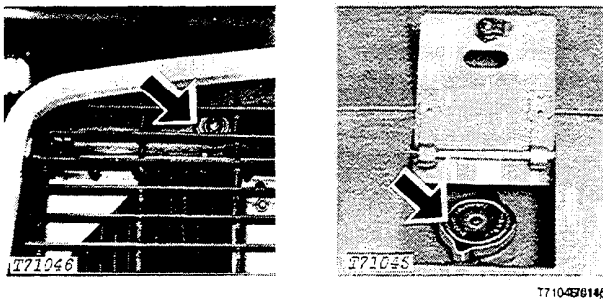

Fig. 34-Checking Coolant Level

Coolant should be seen in sight glass when engine is cold. If not, remove radiator cap.

CAUTION: Do not remove radiator cap unless the engine is cool. Then loosen the cap slowly to the stop. Release pressure before removing cap.

Add clean soft water for warm weather or a solution of 50% clean water and 50% ethylene glycol (permanent type antifreeze with approved rust inhibitor) for cold weather. Tighten the filler cap.

IMPORTANT: Do not use methoxy propanol anti-freeze (such as Dowtherm 209 antifreeze or its equivalent) in the coolant solution. It may damage the cylinder sleeves and seals. This antifreeze is also not compatible with either the Precharge or Service filters.

Check cooling system for loose connections and leaks.

Coolant level checked Yes No

23. Engine Belts (26)

Check the tension of the engine belts.

Strand Tension Gauge

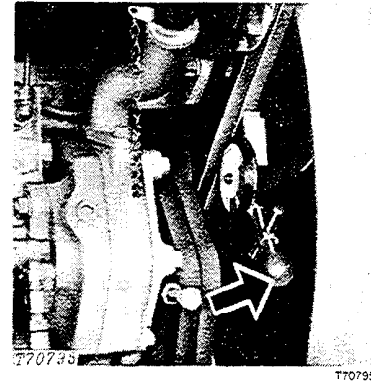

Fig. 35-Strand Tension Gauge on Front Alternator Belt

Run the engine 5 minutes. Immediately after the engine stops, check belt tension of front alternator belt and front fan belt.

If tension is less than 223 N (50 lb.), let the engine cool 10 to 15 minutes. Then make tension 400 N (90 lb.).

Tension Tester

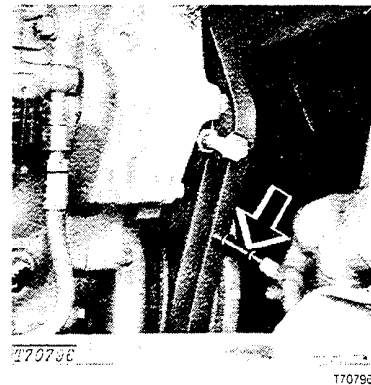
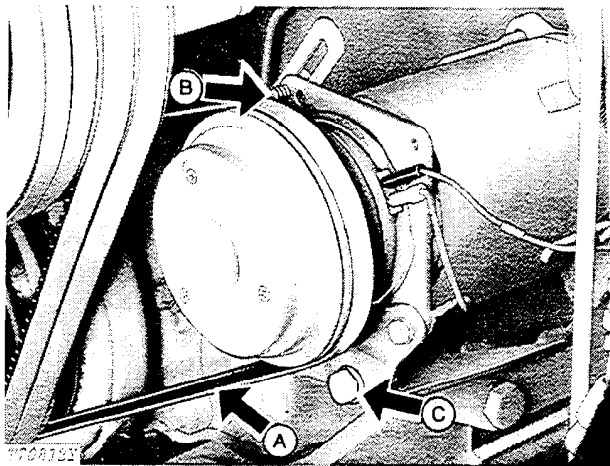

Fig. 36-Tension Tester on Front Fan Belt

Check front alternator and front fan belt. A force of 27 N (20 lb.) halfway between pulleys should move the belt 19 mm (3/4 in.).

Compressor Belt



A—Compressor Belt
B—Adjusting Strap Cap Screw
C—Mounting Cap Screw

Fig. 37-Compressor Belt Tension

Strand tension: 400 N (90 lb.) measured halfway between pulleys.

Tension tester: 67 N (15 lb.) force halfway between pulleys must move belt 8 mm (5/16 in.).

Adjustment

If any belts need adjustment, see page I-IV-36.

Belt tension checked Yes No

24. Hydraulic System Oil Level (23)

Check oil level when oil is cold. Park scraper on level surface. Lower bowl to ground. Sliding floor must be forward. Ejector gate must be to the rear.

Open the service door on front of cab.

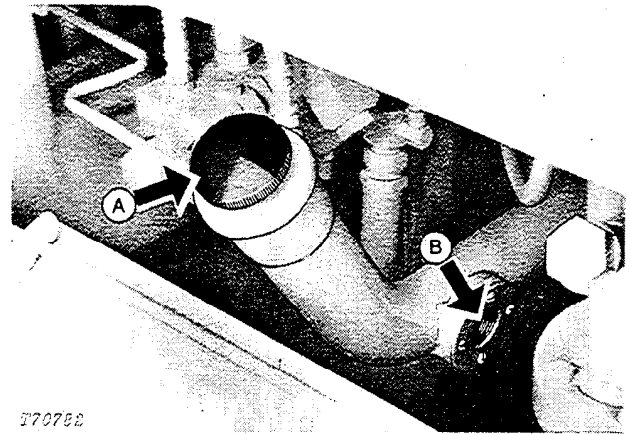

A—Filler Cap
B—Sight Glass

Fig. 38-Hydraulic Oil Level

Oil should be to middle of sight glass.

If not, add oil specified on page I-V-3.

Do not overfill.

Hydraulic oil level checked Yes No

25. Transmission Oil Level (10)

Check transmission oil level.

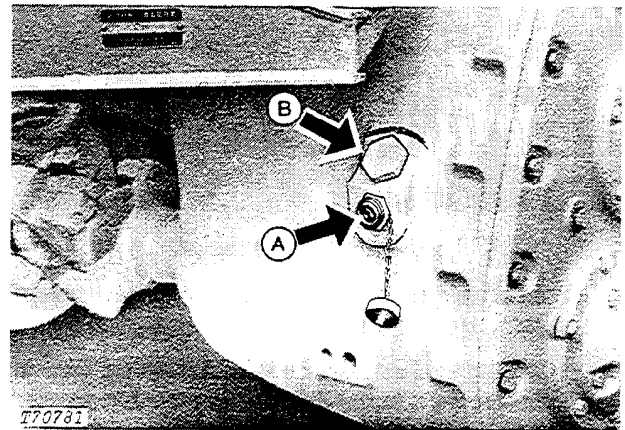

A—Sight Glass
B—Filler Plug

Fig. 39-Transmission Oil Level

Park scraper on a level surface. Lower bowl to ground. Run engine at slow idle. Sight glass must be full of oil. If not, remove filler plug. Add oil specified on page I-V-3. Install filler plug and sight glass cover.

Transmission oil level checked Yes No

26. Drive Axle Oil Level (39)

Check the drive axle oil level.

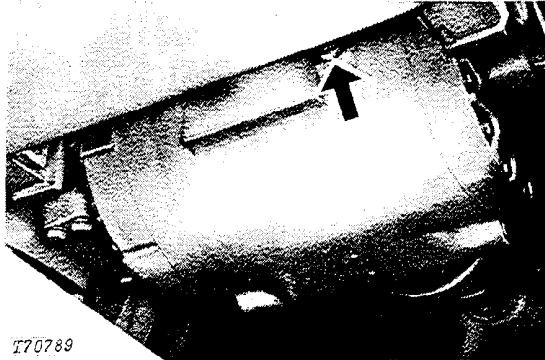

T70789

Fig. 40-Fill Plug

T70789

Remove fill plug. Oil must be to level of the fill plug. If not, add oil specified on page I-V-3. Install plug.

Drive axle oil level checked Yes No

27. Elevator Gearbox Oil Level (46)

Check the elevator gearbox oil level.

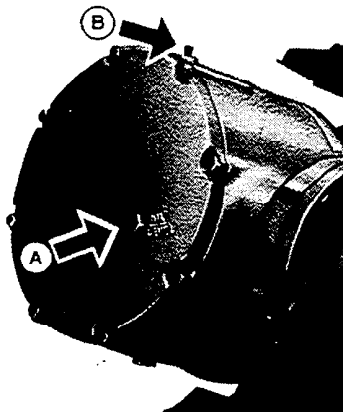

T70740

T70740

A—Check Plug

B—Fill Plug

Fig. 41-Elevator Gearbox Oil Level

1 - Remove check plug (A). Oil should be level with plug.

2 - If not, remove fill plug (B). Add oil specified on page I-V-3.

Install check plug and fill plug.

Elevator gearbox oil level checked

Yes No

28. Fuel Pump (4)

The electric fuel pump is in the left (L.H.) rear side of the scraper bowl next to the fuel tank.

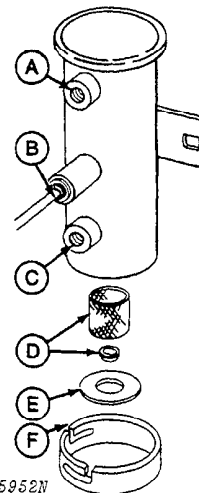

T65952N

T65952N

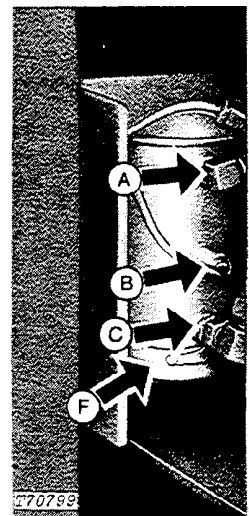

T70799

T70799

A—Fuel Outlet
 B—Wiring Lead
 C—Fuel Inlet

D—Filter and Magnet
 E—Gasket
 F—Bottom Cover

Fig. 42-Electric Fuel Pump

Close the fuel tank shut-off valve.

Remove cover (F), gasket (E), magnet and filter (D). Clean the magnet. If the filter is dirty or damaged, install a new one.

Install the magnet and filter, cover, and gasket. Open the shut-off valve.

Remove air from the fuel system.

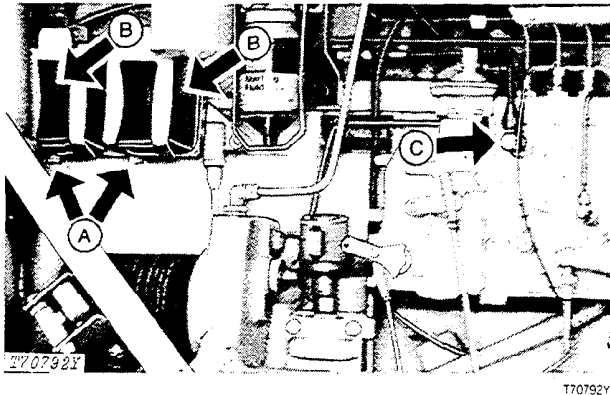

A—Drain Screws
 B—Fuel Filters
 C—Fuel Line Fitting

Fig. 43-Removing Air From Feed System

1. Be sure there is enough fuel in the fuel tank.
2. Loosen the fuel line fitting (C).
3. Turn the key switch on. The electric fuel pump will pump fuel.
4. Wait until fuel free from air bubbles flows from the fitting.
5. Tighten the fitting.
6. Turn the key switch off.

Fuel pump checked Yes No
 Air removed from fuel system Yes No

29. Tires (49)

Check air pressure in all tires with an accurate gauge having 7 kPa (1 psi) graduations.

NOTE: Do not use tire ballast.

Tire Size	Type	Ply Rating	Pressure Psi (kPa)
26.5 x 29	Steel Cord		
	Radial		50 (345)
26.5 x 25	E2	24	55 (380)
26.5 x 29	E2	26	50 (345)
26.5 x 25	Steel Cord		
	Radial		55 (380)

Tire pressures can be changed to suit working conditions, according to tire manufacturer's recommendations.

Tire pressure checked Yes No

30. Wheel Cap Screws (53)

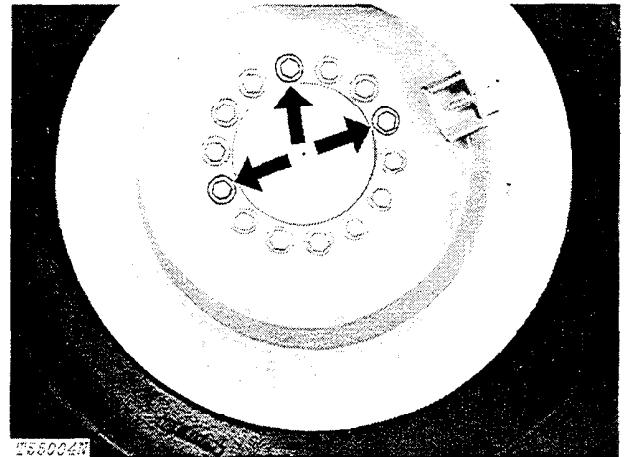

Fig. 44-Front Wheel Cap Screws

Tighten cap screws on all four wheels (56 total) to 542 N·m (400 lb-ft).

Cap screws checked Yes No

31. All Grease Fittings

All grease fittings were checked and lubricated before the scraper left the factory. However, to make sure of customer satisfaction, check each lubrication point shown on the following pages. Lubricate with several strokes of John Deere Multi-Purpose Grease or equivalent, if necessary.

CAUTION: Before lubricating always stop the engine and lower the bowl to the ground.

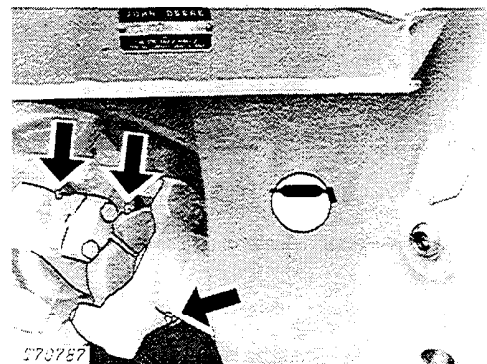

Fig. 45-Axle Drive Shaft Universal Joints (3 points)

Lubrication required Yes No

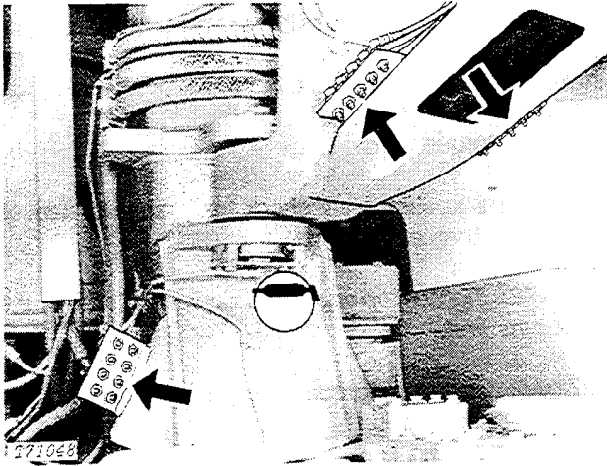

Fig. 46-Oscillation Hitch Pivots, Steering Links, and Cylinder Pivots (18 points)

Lubrication required

Yes No

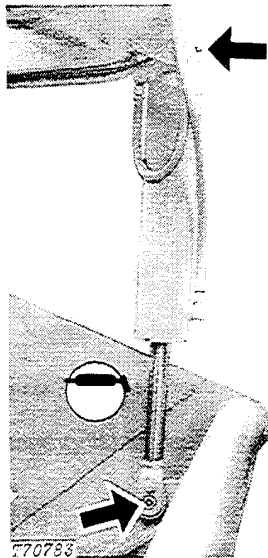

Fig. 47-Cylinder Pivots (4 points)

Lubrication required

Yes No

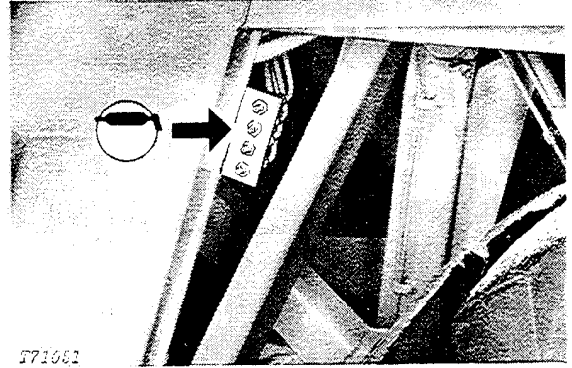

Fig. 48-Sliding Floor Lever and Cylinder Pivots (4 points)

Lubrication required

Yes No

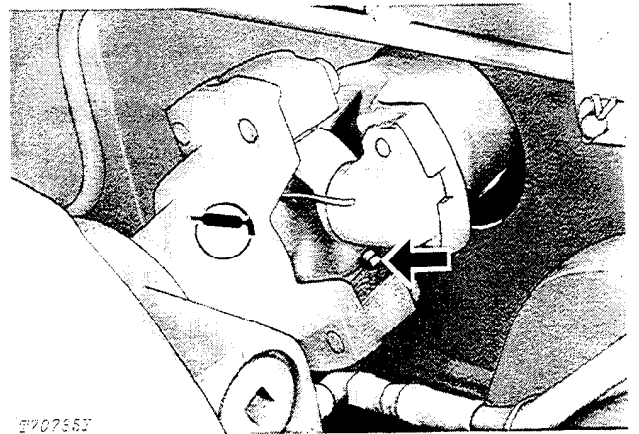

Fig. 49-Transmission Drive Shaft Universal Joints and Tube (rear joint) (1 point)

Lubrication required

Yes No

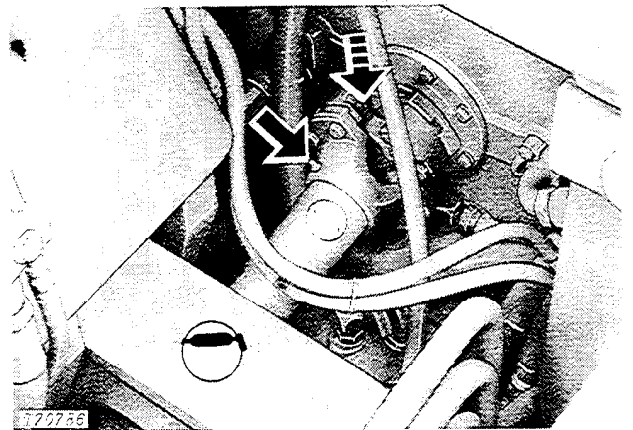

Fig. 50-Transmission Drive Shaft Universal Joints and Tube (front joint) (2 points)

Lubrication required

Yes No

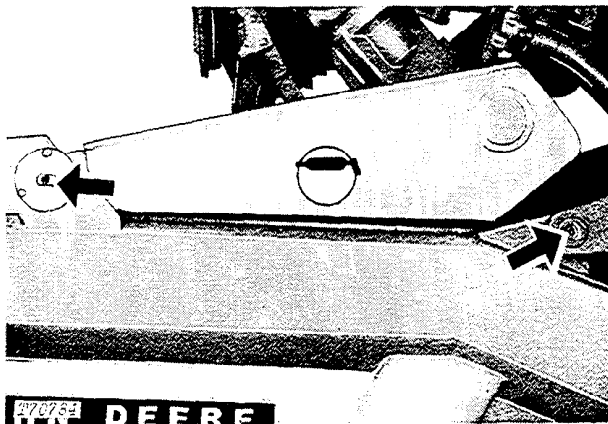

Fig. 51-Draft Frame and Elevator Pivots
 (4 points)

T70784

Lubrication required Yes No

32. Tighten Oscillation Hitch Pivots Cap Screws

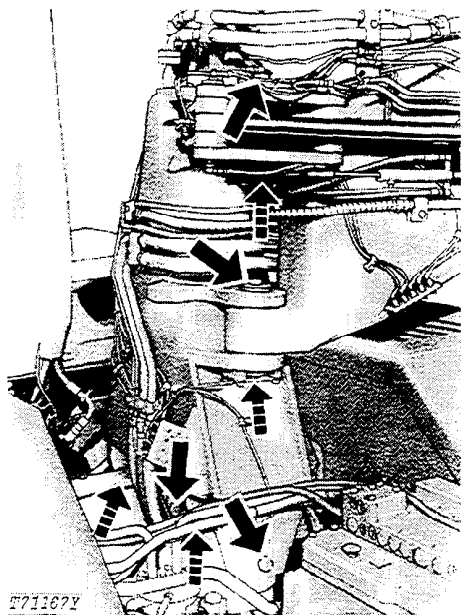

Fig. 52-Oscillation Hitch Pivot Pin Cap Screws
 (8 points)

T71167

Tighten bolts to 670 lb-ft (908 N·m).

Shock load tapered sleeves with a brass, lead or aluminum hammer.

If washers are accessible and large enough, strike both washers in three places.

If washers are not accessible or are too small to strike directly, place a spacer over bolt head or bolt nut and strike spacer three times. Do not strike bolt head or nut.

Check torque again.

Continue to alternately shock load tapered sleeves and check torque.

NOTE: Tighten top cap screws in vertical draft frame pivot pins first.

Check cap screw torque after the first 10 hours, 50 hours, and 200 hours.

NOTE: After disassembly and assembly of pivots, cap screw torque should be checked daily on three consecutive days.

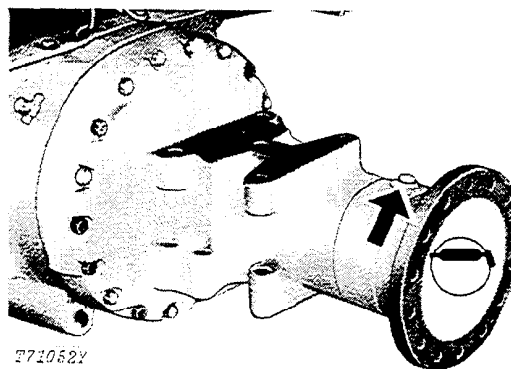

Fig. 53-Drive Axle Outer Bearings (2 points)

T71052Y

T71052Y

NOTE: Remove pipe plug. Install grease fitting.

Lubrication required Yes No

33. Accessible Hardware Torque Values

Check all accessible hardware. If hardware is loose, tighten it to the correct torque. See the torque charts in Group III.

All accessible hardware checked Yes No

34. Fluid Leakage

Check the following systems for leakage. Check for broken hoses, broken lines, and loose or worn connections:

A. Cooling system checked	Yes	No
B. Hydraulic system checked	Yes	No
C. Fuel system checked	Yes	No
D. Lubrication system checked	Yes	No
E. Air intake system checked	Yes	No

35. Radiator Air Flow Pre-Test Inspection

CAUTION: DO NOT remove radiator cap until radiator top tank feels cool.

1. Check coolant level.
2. Check belt strand tension. Adjust belt if necessary. See page IV-11.
3. Check radiator fin condition. Make sure fins are not bent or damaged.
4. Check fan blade tips (A), shroud (B), and baffle (C), for damage. Fan blade tip to shroud distance must be equal at top and bottom.
5. Check for sucker fan installation.

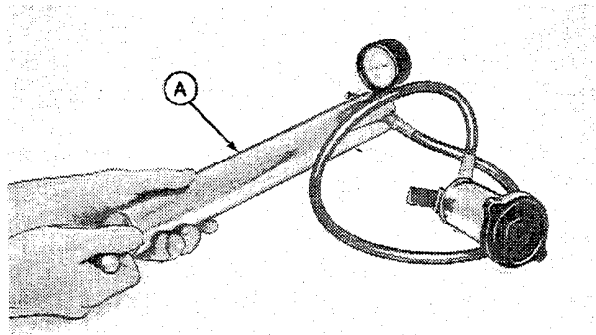

Fig. 53A-Testing Radiator Cap

T824B3

6. Connect radiator cap to a D-05104ST Pressure Pump (A). Raise pressure until cap valve opens. Valve must hold pressure at 43 to 50 kPa (0.43 to 0.51 bar) (6.25 to 7.50 psi) for one minute. If pressure decreases, install a new cap.

36. Radiator/Oil Cooler Air Flow Test

1. Apply parking brake, put transmission in neutral, lock reverser lever in neutral, and start engine.
2. Remove side shields and grill screen.
3. Divide the surface of radiator into 16 equal squares with white chalk lines on the front of the radiator.
4. Install a D-01084AA Tachometer/Temperature Reader on the machine. Start engine and check low idle. Low idle must be 925 rpm.
5. Run engine at 1025 rpm.

6. Connect JTO5529 Air Flow Meter to D-27501BM Digital-Multimeter or JT27504 Heavy Duty Digital Multimeter. Turn switch on multimeter to 20 volts AC.

IMPORTANT: Unit is equipped with a sucker fan.

Direction arrow on Air Flow meter must be toward radiator.

7. Hold Air Flow Meter in direct contact with radiator with direction arrow toward radiator. Hold multimeter with other hand and stand to side of unit to prevent interference with air flow. Make a record of the multimeter reading for each square.

8. Compare readings to Pre-Delivery Inspection records or repeat entire procedure on a new unit, with the same equipment for comparison. If readings are reduced by 20% or more, remove oil cooler. Clean external surfaces of both oil cooler and radiator. Install oil cooler.

Air Flow Test Readings

Record sum of individual values for future reference:

T94610

37. Final Check

Clean the whole unit. Make the unit LOOK like a new machine. Touch up any chipped paint. Wash the machine thoroughly. Deliver to the customer a machine anyone would be proud to own.

DELIVERY SERVICE

A thorough discussion of the operation and service of a new machine at the time of delivery helps to assure complete customer satisfaction. Proper delivery should be an important phase of a dealer's program. A portion of the John Deere Delivery Receipt emphasizes the importance of proper delivery service.

Many complaints arise simply because the owner was not shown how to operate and service a new machine properly. Devote enough time, at the customer's convenience, to introduce the owner to the new scraper and explain how to operate and service it.

The following procedure is recommended before the service technician and owner complete the delivery acknowledgments portion of the Delivery Receipt.

Using the operator's manual as a guide, be sure that the owner understands these points thoroughly:

1. The importance of safety.
2. The importance of lubrication and periodic services.
3. The importance of the break-in period.
4. Controls and instruments.
5. How to start and stop the engine.
6. All functions of the hydraulic system.

After explaining and demonstrating the above features, have the owner sign the Delivery Receipt and give the owner the operator's manual.

AFTER-SALE INSPECTION

The purchaser of a new John Deere machine is entitled to a free inspection at some mutually agreeable time within the warranty period after the equipment has been "run-in," usually after 50 to 100 hours of machine operation. The terms of this after-sale inspection are outlined on the customer's John Deere Delivery Receipt.

The purpose of this inspection is to make sure that the customer is receiving satisfactory performance from the scraper. At the same time, the inspection should reveal whether or not the machine is being operated, lubricated, and serviced properly.

If the recommended after-sale service inspection is followed, the dealer can eliminate a needless volume of service work by preventing minor irregularities from developing into serious problems later on. This will promote strong dealer-customer relations and present the dealer an opportunity to answer questions that may have arisen during the first few days of operation.

During the inspection service, the dealer has the further opportunity of promoting the possible sale of other new equipment.

Check operation of all controls and instruments for freedom of movement and correct operation.

**Numbers in parenthesis are same as item numbers on the periodic maintenance chart on your scraper.*

1. Cab Equipment

Check the operation of the following equipment: seat belt, right (R.H.) window, vandal cover and locks, door, steering wheel, dome light, auxiliary heater. Make adjustments, if necessary.

Cab equipment checked Yes No

2. Seat

Check the operation of the seat.

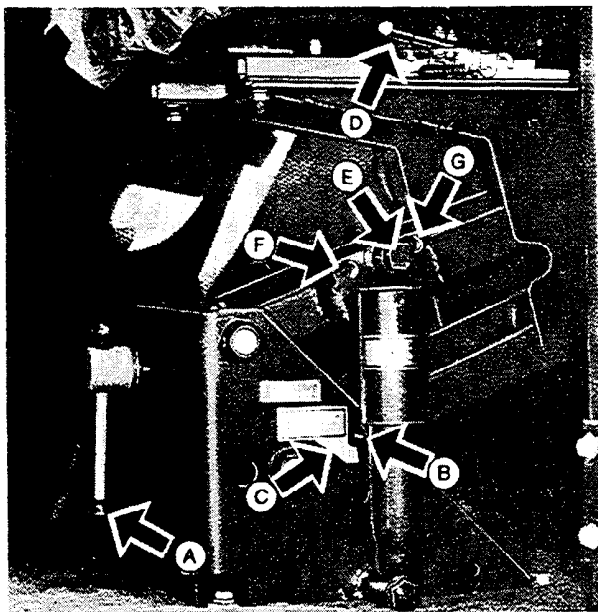

T84922

- A—Weight Adjustment Lever
- B—Pointer
- C—Ride Zone
- D—Forward or Rearward Adjustment Lever
- E—Cap Screw
- F—Soft Ride
- G—Firm Ride

Fig. 54-Seat

Adjustment for Weight

While seated, turn lever A clockwise to lower the seat. Turn the lever counterclockwise to raise the seat.

Change the height so the pointer (B) is in the ride zone (C).

Adjustment Forward or Rearward

While seated, move lever (D) to the left (L.H.). Slide the seat to the desired position. Release the lever.

Adjustment for Ride

Install the shock absorber cap screw (E) in the front hole (F) for a soft ride, or in the rear hole (G) for a firm ride.

Up-Latch Lever

While seated, pivot lever E rearward before standing to lock the seat in position.

The lever will automatically release when you sit.

Seat operation checked Yes No

3. Gauges, Switches, and Indicator Lights

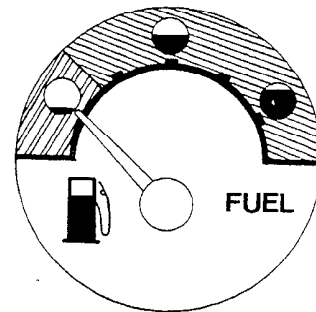

T40227N

T40227N

Fig. 55-Fuel Level Gauge

Add a small amount of fuel to the fuel tank. Check the action of the fuel gauge.

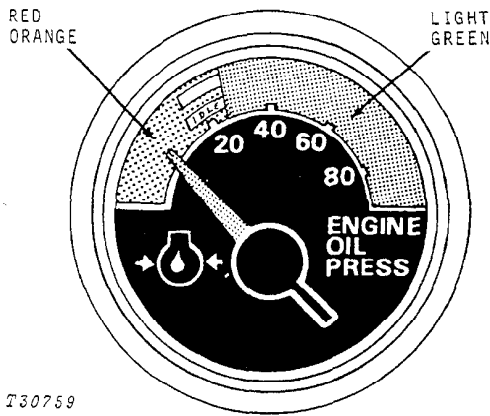

T30759

Fig. 56-Engine Oil Pressure Gauge

Normal operating range is 170-550 kPa (1.7-5.5 bar) (25-80 psi).

If the indicator hand goes into the red-orange zone, stop the scraper. Check the engine oil level. If the oil level is not low, check for restrictions in the oil lines or wrong viscosity oil.

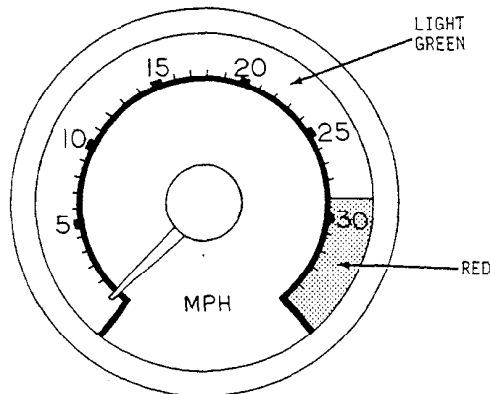

T55469N

Fig. 57-Speedometer

The speedometer shows scraper speeds from 0 to 55 km/h (0 to 34 mph). Red background at 47 km/h (29 mph) and above shows overspeed.

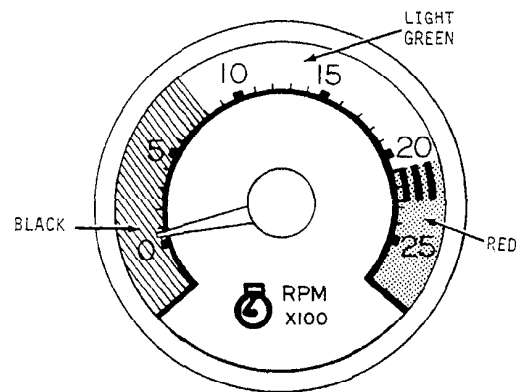

T72037

Fig. 58-Tachometer

The tachometer shows engine rpm from 0 to 2500 rpm. Normal operating range is 925 to 2300 rpm.

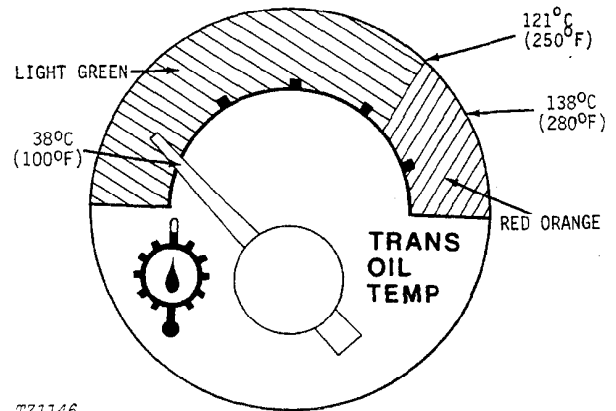

T71146

Fig. 59-Transmission Oil Temperature Gauge

The light green zone shows the normal operating range, 38-121°C (100-250°F).

If the indicator hand enters the red zone, operate in a lower gear. If the hand remains in the red zone, check the transmission oil level.

If these possible solutions do not lower the oil temperature, do not operate the scraper.

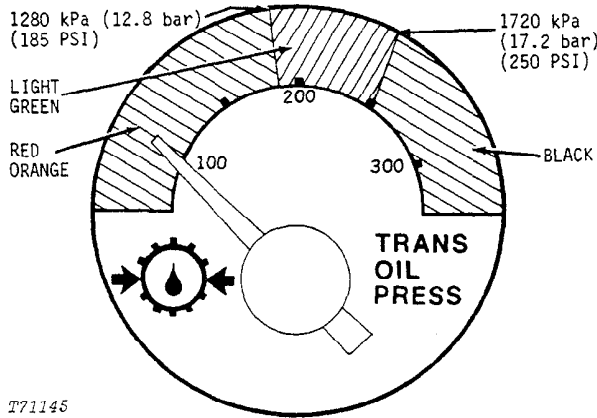

T71145

Fig. 60-Transmission Oil Pressure Gauge

The light green zone shows the normal operating range.

IMPORTANT: If the indicator hand is in either red-orange zone or black zone, stop the scraper and find the cause.

NOTE: During cold weather, the gauge will normally read high for a short time after the engine starts.

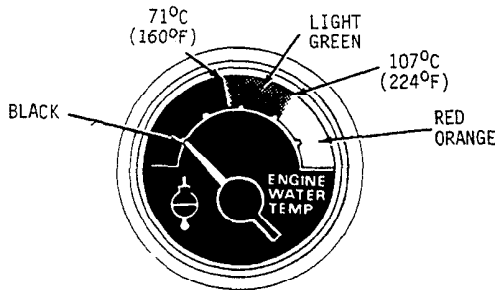

T71147

Fig. 61-Engine Coolant Temperature Gauge

The light green zone shows the normal operating temperatures, 71-107°C (160-224°F).

IMPORTANT: If the indicator hand goes into the RED-ORANGE ZONE, stop the engine and find the cause.

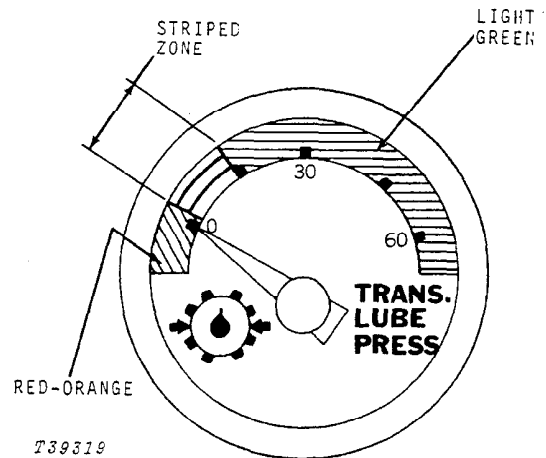

T39319

Fig. 62-Transmission Lube Pressure Gauge

When engine is running at slow idle, the gauge must show in striped zone. When operating under constant heavy loads, the gauge must show in the light green zone.

DO NOT operate the scraper when the needle is in the red-orange zone. If needle is in this zone, stop the scraper. Check transmission filter. If filter is not clogged and needle is still in red-orange zone, see your John Deere dealer.

NOTE: Transmission lube pressure will vary with engine speed and oil temperature.

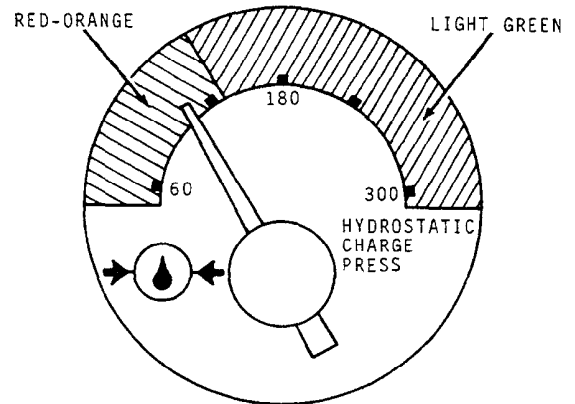

T61271N

Fig. 63-Hydrostatic Charge Pressure Gauge

Normal operating range is in light green zone. If gauge registers in red-orange zone, stop the scraper. Find the cause.

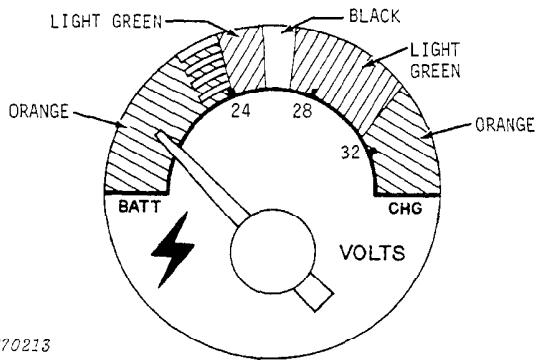

T70213

Fig. 64-Voltmeter

T70213

Normal operating range is indicated by the right (R.H.) green zone.

If the indicator hand is not in this green zone, troubleshoot the electrical system.

Check the operation of the switches.

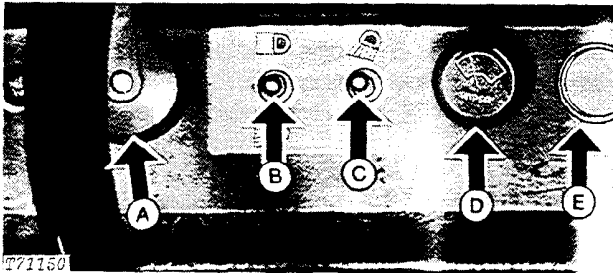

T71150

Fig. 65-Switches

T71150

- A - Turn Signal Switch - Lift switch to flash right (R.H.) turn signal. Push down switch to the first position to flash left (L.H.) turn signal. Push switch all the way down to flash all four turn signal lights.
- B - Head Light Switch - Activate switch to turn on headlights and taillights. Push switch up for bright lights. Push down to dim lights.
- C - Work Light Switch - Activate switch to turn on two rear work lights.
- D - Wiper Switch - Turn switch clockwise for low or high speed wiper action.
- E - Starting Aid Button - Remove starting fluid can from engine. Push starting aid button. Listen for solenoid click.

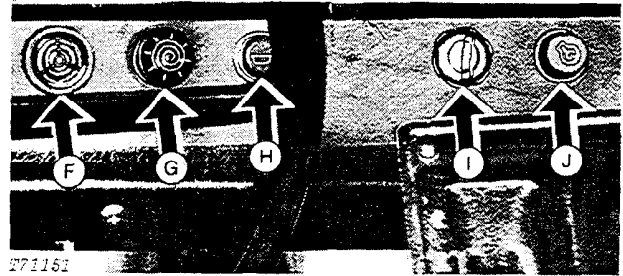

T71151

Fig. 66-Switches

T71151

- F - Buzzer - Read information on indicator lights below.
- G - Cigar Lighter - Push to activate.
- H - Horn Switch - Push the button to sound dual horns.
- I - Ignition Switch - Turn the key clockwise to turn the switch on. No other switches or gauges work unless the ignition switch is on.
- J - Starter Switch - Push the button to start the engine.

Check operation of indicator lights.

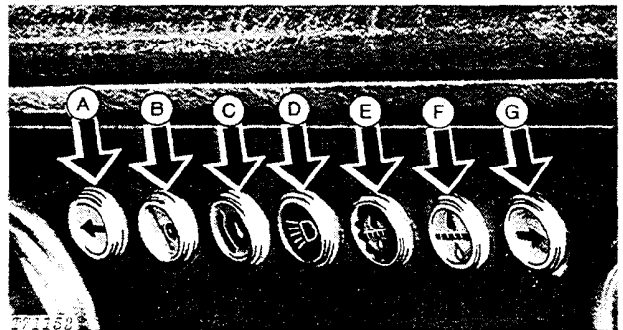

T71152

Fig. 67-Indicator Lights

T71152

- A - Left (L.H.) Turn Indicator Light - Flashes for left turn and emergency flashing.
- B - Parking Brake Indicator Light - Glows when parking brake is engaged and key switch is on. Buzzer will sound at intervals.
- C - Brake Pressure Indicator Light - Glows when pressure in system falls below 10,500 kPa (105 bar) (1525 psi). Buzzer will sound at intervals. Light may glow briefly after engine starts until pressure goes above 10,500 kPa (105 bar) (1525 psi). If this light glows when scraper is operating, stop scraper and find cause.

- D - High Beam Indicator Light - Glows blue when headlights are on.
- E - Transmission Filter Restriction Indicator Light - Glows when transmission filter is plugged. Also glows during warm-up when oil is cold. Buzzer will sound at intervals.
- F - Hydraulic Filter Restriction Indicator Light - Glows when hydraulic filter is plugged. Also glows during warm-up when oil is cold. Buzzer will sound at intervals.
- G - Right Turn Indicator Light - Flashes for right (R.H.) turn and emergency flashing.

Gauges, switches, and indicator lights checked

Yes No

4. Transmission Operation

Check the operation of the transmission.

Controls

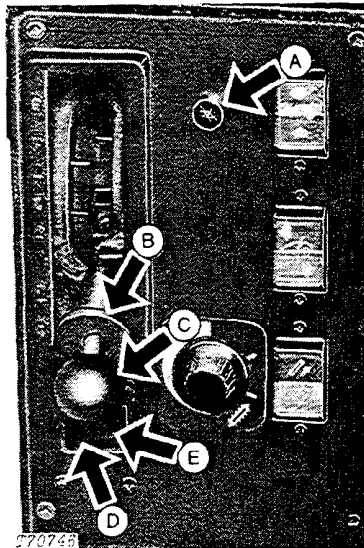

Fig. 68-Transmission Controls

- A - Transmission Indicator Light - If light glows amber, transmission is in automatic mode. If light is off, transmission is in manual mode.

- B - Neutral Lock - Lift sleeve before moving shift lever from neutral into reverse or first gear. Lift sleeve before moving lever from first gear to neutral. Move lever from reverse to neutral without lifting sleeve.
- C - Gear Shift Lever - Move lever to desired gear.
- D - Gear Indicator Light - Shows the gear the transmission is in. Also shows neutral ("0") and reverse (-[minus sign]). When shift lever is in neutral, the light flashes available gears if transmission electrical system is not working correctly.
- E - Lockup Indicator Light - Light shows "L" when the lockup clutch locks a gear in direct drive. Light also flashes if transmission lockup electrical system is not working correctly.

Check the operation of the transmission in the three shift patterns in automatic mode.

Transporting Shift Pattern

1. Move shift lever to 6th gear.

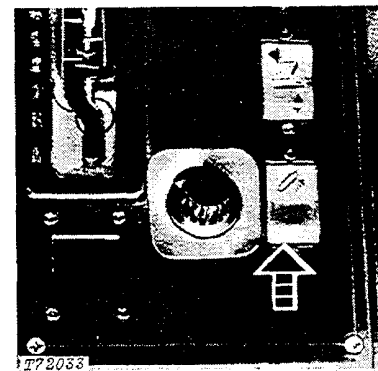

Fig. 69-Elevator Switch (unloading)

2. Move the elevator switch to unload position (Fig. 69) or to neutral.
3. Push down accelerator.
4. Transmission should shift: 3TC*, 4TC, 4L+, 5TC, 5L, 6TC, 6L.

- * - Torque Converter Drive
- + - Lockup in Direct Drive

Loading Shift Pattern

1. Move shift lever to 6th gear.

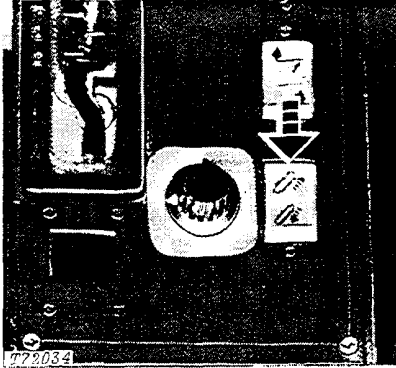

Fig. 70-Elevator Switch (loading)

T72034

2. Move the elevator switch to loading position.
3. Push down accelerator.
4. Transmission should shift: 1TC, 2TC, 3TC, 4TC, 5TC, 6TC.

Downshift Pattern

1. Drive the scraper in 6L gear.
2. Release the accelerator.
3. Transmission should shift: 6L, 5L, 4L, 3TC.

NOTE: To make a manual downshift, move the shift lever to the next lower gear. Do not manually downshift more than one gear lower at a time. Do not manually downshift above 1800 rpm.

Check the operation of the hold pedal.

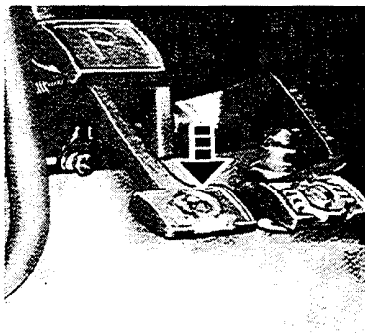

Fig. 71-Hold Pedal

T72032

Use pedal only when transmission is in automatic mode.

Push down pedal. Transmission will operate as follows:

1. Will not shift out of gear it is in.
2. If in torque converter drive, transmission will stay in torque converter drive.
3. If in direct drive ("L" shows on lockup indicator), will stay in direct drive.

Diagnostics of Transmission Electrical System

1. If the transmission electrical system is not working correctly, the transmission will automatically shift to 4th gear. The gear indicator will flash "4". If 4th gear is not working, the transmission will shift to neutral and the indicator will flash "0".

NOTE: If lockup electrical system is not working, the lockup indicator will flash.

2. Move the shift lever to neutral.
3. The gear indicator will flash the gears that are working.
4. Switch to manual operation. Use only the working gears.

Transmission checked

Yes No

5. Differential Lock Operation

Check the operation of the differential lock.

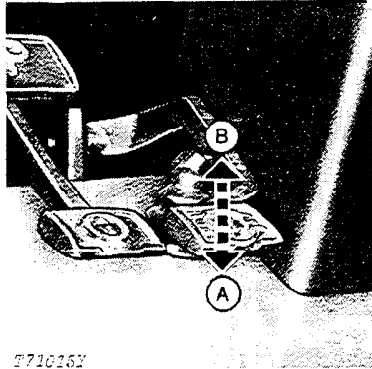

Fig. 72-Differential Lock Pedal

Start the engine. Engage the lock (A). Turn the steering wheel. If the lock is working correctly, steering resistance will be felt.

Differential lock checked Yes No

6. Engine Speed Linkage (30)*

Check engine speeds when engine is at normal operating temperature.

IMPORTANT: Use only a calibrated tachometer to check engine speeds.

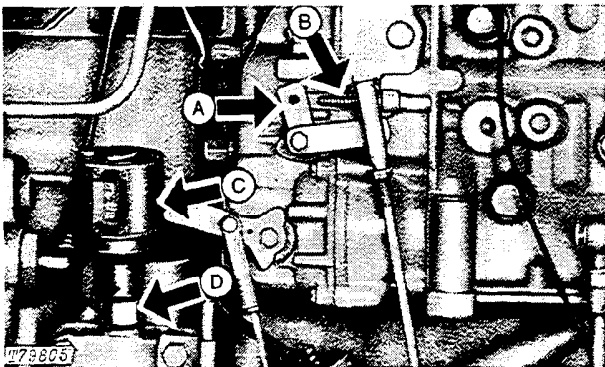

A—Control Lever C—Service Meter
 B—High Speed Stop Screw D—Tachometer Drive

Fig. 73-Checking Engine Speeds

Remove service meter (C). Connect calibrated tachometer to tachometer drive (D).

Slow idle must be 925 rpm. Fast idle must be 2325 rpm.

*Numbers in parenthesis are same as item numbers on the periodic maintenance chart on your scraper.

If adjustment is needed, follow the procedure below.

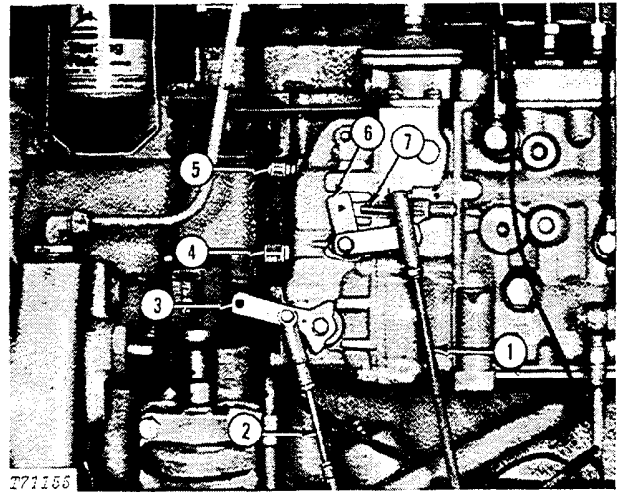

Fig. 74-Adjusting Engine Speeds

Disconnect speed control cable (1, Fig. 74) and engine stop cable (2) from injection pump. Fuel shut-off lever (3) must be all the way down.

Remove supplementary idling spring cover (4). Back out the adjusting screw until engine speed begins to change. Back out the screw a little more.

Remove cover from slow idle adjustment screw (5). Turn the screw until slow idle is 905 rpm. Tighten the lock nut.

Turn in idling spring adjustment until engine runs at 925 rpm. Tighten the lock nut.

Hold speed control lever (6) against fast idle stop screw (7). Turn the stop screw until the engine runs at 2325 rpm.

Install covers (4 and 5). Install lead seal on fast idle adjusting screw.

Connect two cables (1 and 2). Adjust as necessary for full travel.

Engine speeds checked Yes No

7. Accumulator Action (24)

Check brake accumulator action. Brakes should operate for several applications after engine is stopped. Brakes should be solid for a minimum of five applications.

Accumulator checked Yes No

8. Brakes

Check the operation of the hydraulic brakes.

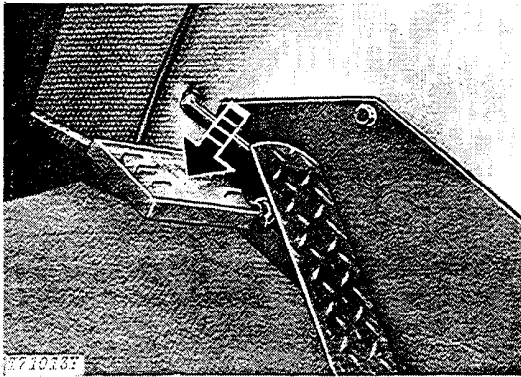

Fig. 75-Brake Pedal

T71013Y

Put the scraper in gear. Push down the brake pedal. Moderate pedal force must hold the machine in place.

Remove air from the brake system:

1. If moderate pedal force does not hold the machine in place.
2. If the pedal feels spongy.
3. If the pedal jumps back when it is pushed down.
4. If the pedal has too much travel.

CAUTION: Before removing air from the brake system, lower the bowl, stop the engine, engage the parking brake, put the transmission in neutral.

CAUTION: Removing air from the brake system is a two-person job: one person must be in the operator's station at all times during this procedure.

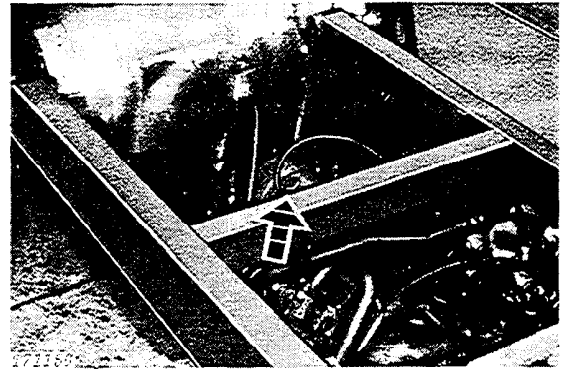

Fig. 76-Pump Shut-Off Screw

T71156

Before removing air from the brakes, follow this procedure to release excessive pressure at the bleed screws:

1. Close the shut-off screw (turn clockwise) on the main hydraulic pump to destroke the pump. Pump is on torque converter at the rear of drive axle.
- 2 - Turn the steering wheel back and forth until no response is felt.
- 3 - Pump the brakes until no response is felt.

Removing Air From The Tractor Brakes

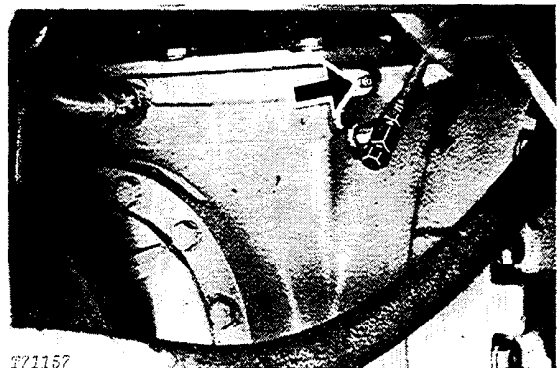

Fig. 77-Tractor Bleed Screw

T71157

Tractor brakes: Put the end of the tube in a container of oil specified for drive axles on page I-V-3. Fasten the other end to the bleed screw. When the engine is running at slow idle, push down brake pedal. Loosen the bleed screw about 3/4 turn. Let air and oil flow into the container until no more bubbles are seen.

After removing air, tighten the bleed screw when the pedal is pushed down. Remove the hose. Remove air from both brakes in the same manner.

Removing Air From The Scraper Brakes

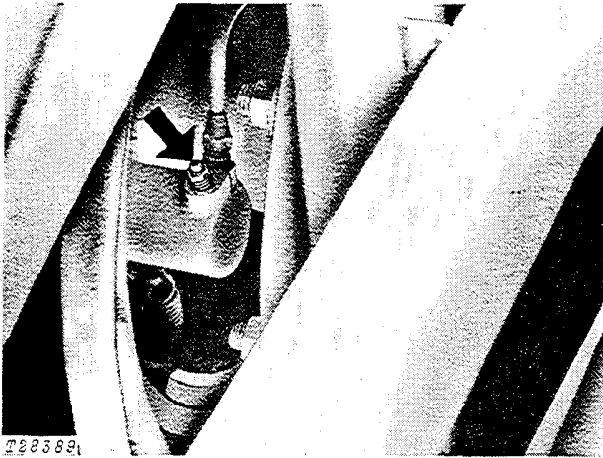

Fig. 78-Scraper Bleed Screw

Scraper brakes: Fasten a tube to the bleed screw on the rear wheel cylinder. Put the end of the hose in a container of oil specified for drive axles on page I-V-3. Start the engine. Push down the brake pedal. Loosen the bleed screw about 3/4 turn. Let air and oil flow into the container until no more bubbles are seen.

After removing air, tighten the bleed screw when the pedal is pushed down. Remove the hose. Remove air from both brakes in the same manner.

Check the hydraulic reservoir oil level. (See page I-IV-14).

IMPORTANT: When removing air from the scraper brakes, be careful not to get oil on the brake shoes.

Brake action checked	Yes	No
Air removed from brakes	Yes	No

9. Parking Brake

Check action of parking brake.

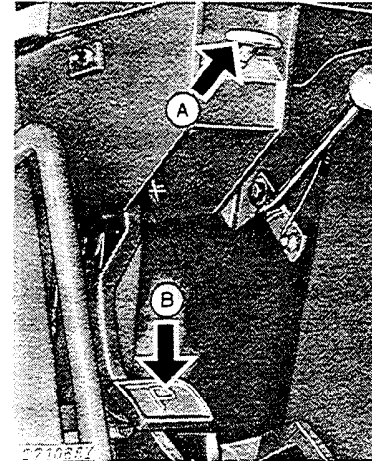

A—Release Handle B—Parking Brake Pedal

Fig. 79-Parking Brake

Push down pedal (B) firmly. Pedal must not move more than four notches.

If adjustment is needed, follow the steps below.

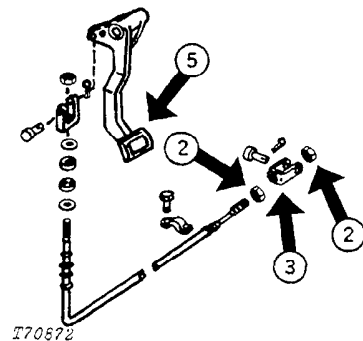

Fig. 80-Parking Brake Adjustment

1. Release the parking brake. Push pedal down slightly. Pull release handle (A, Fig. 79).
2. Loosen two lock nuts.
3. Move cable end to desired position.
4. Tighten lock nuts.
5. Engage parking brake. If pedal moves more than four notches, repeat steps 1-4.

Parking brake checked	Yes	No
-----------------------	-----	----

10. Cycle Times

Check cycle times when the oil is warm and the engine at fast idle.

NOTE: Operate each hydraulic control until all air has been removed from the hydraulic system. Check all controls for freedom of movement and proper direction of travel before checking cycle times.

Use the following times as a guide. If cycle times are much different from those listed, trouble shoot the hydraulic system.

	Seconds
Elevator Speed (one complete revolution)	6.0 max.
Raise Bowl	2.5 - 3.5
Lower Bowl	3.5 - 4.0
Eject or Return Cycle	7.0 - 8.0
Steering (180° turn to right and left)	5.0 - 5.5 (Either Direction)

While checking cycle times, make a note of any equipment that is not working correctly.

When the engine is at slow idle (925 rpm), turn the steering wheel from stop to stop. Turn the steering wheel faster than normal to "force the turn". This will remove air from the steering system.

Cycle times checked Yes No

Malfunctions _____

11. Air Conditioner

Check the air conditioner controls.

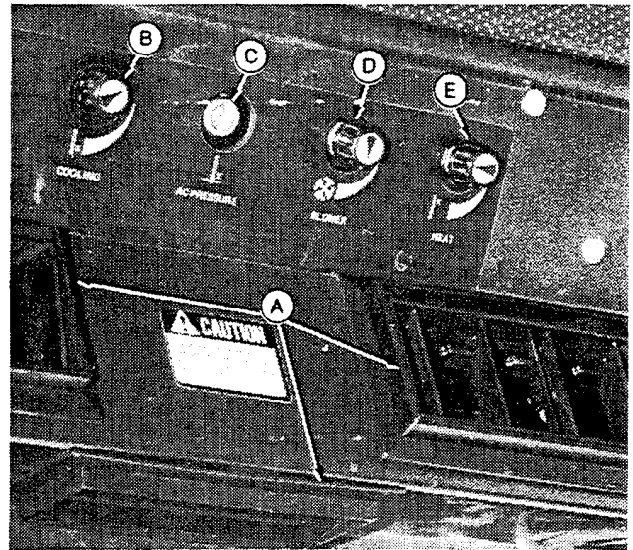

A—Louvers
 B—Temperature Control Knob
 C—Refrigerant Pressure Indicator Light
 D—Blower Control Knob
 E—Heater Control Knob
 F—Louvers

Fig. 81-Air Conditioner Controls

- A - Turn knob to recirculate air or to bring in outside air.
- B - Turn knob clockwise for cooling.
- C - If indicator light goes on, see Section 90, Group 9031.
- D - Turn knob clockwise to increase blower speed.
- E - Turn knob clockwise for heat.
- F - Move tab on louver to control direction of air.

12. Cab Recirculating Air Filter (22)

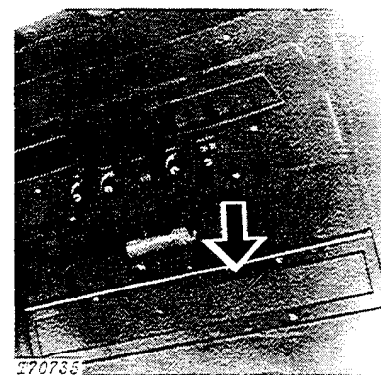

Fig. 82-Recirculating Air Filter

Recirculating filter: Remove cover and filter. Wash filter in warm, soapy water. Rinse and dry.

Controls checked Yes No
 Filters checked Yes No

13. Fresh Air Filter (18)

Check the air filters. Clean elements as necessary.

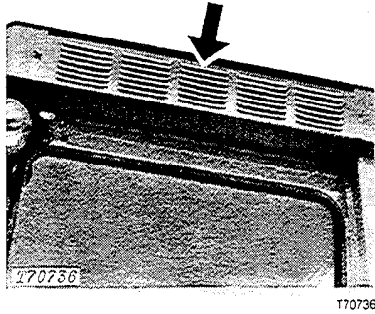

Fig. 83-Outside Air Filter

Outside air filter: Remove cover. Pull out filter.

Clean filter by:

- Tapping filter on flat surface, dirty side down.
- Blowing low pressure compressed air through filter opposite to normal air flow.
- Washing filter in warm soapy water. Rinse and dry.

14. Injection Pump Sediment Bowl and Filter (28)

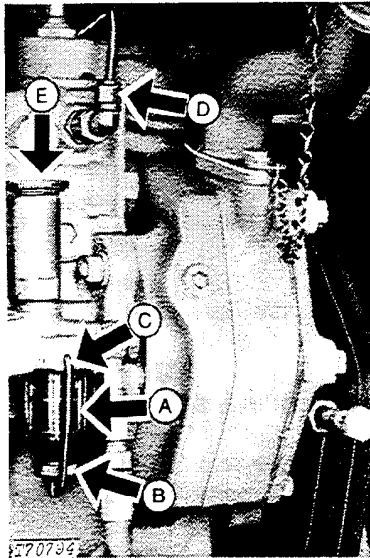

Fig. 84-Sediment Bowl and Filter

Check sediment bowl (A) for dirt and water.

If bowl needs cleaning, loosen nut (B).

Swing clip (C) away from bowl.

Remove bowl and filter

Clean the bowl and filter.

Assemble all parts.

Be sure bowl gasket fits correctly.

Bleed the fuel system.

Bleeding the Fuel System

Loosen fuel line (D).

Loosen the primer (E). Pump the primer until fuel free of bubbles flows from the fuel line.

Tighten the fuel line.

Push the primer down. Tighten it by hand.

15. Water Separator (2)

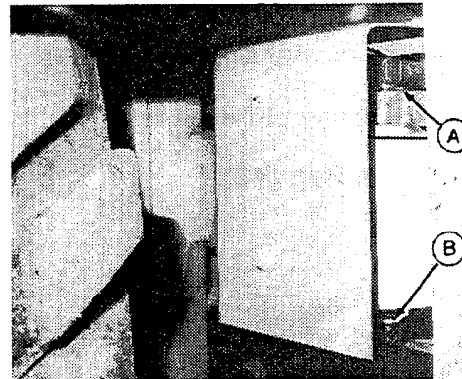

A—Vent Screw

B—Drain Petcock

Fig. 85-Water Separator

The water separator is located on bowl frame, under left rear fender.

Drain water and sediment when engine is cold.

Loosen drain petcock (B) shown.

Drain liquid until fuel flows from petcock.

Tighten drain petcock.

NOTE: If fuel does not flow, loosen vent screw (A).

16. Fuel Tank Sump (1)

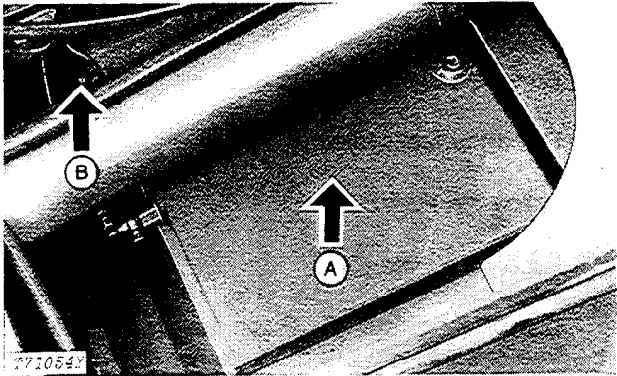

A—Fuel Tank

B—Drain Cock

Fig. 86-Bottom of Fuel Tank

Open drain cock (B).

Drain water or sediment. Close drain cock.

NOTE: Fill fuel tank (A) after shutdown each day.

This view is of the bottom of the fuel tank.

17. Elevator Chain Sag (43)

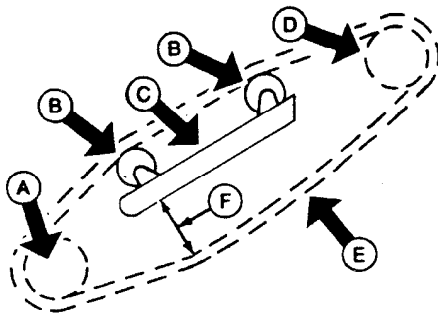

A—Lower Idler
 B—Center Idler
 C—Elevator Frame

D—Upper Idler
 E—Chain
 F—7 to 12 in. (18 to 31 cm)

Fig. 87-Elevator Chain

Measure chain sag between box section of elevator frame and top of chain sidebar at point of greatest sag.

Sag should be 7 to 12 in. (18 to 31 cm).

If sag is less than 7 in. (18 cm), chain will wear excessively.

If sag is more than 12 in. (31 cm), chain will jump sprocket teeth.

IMPORTANT: Chain sag should not vary more than 1 in. (25 mm) from side to side.

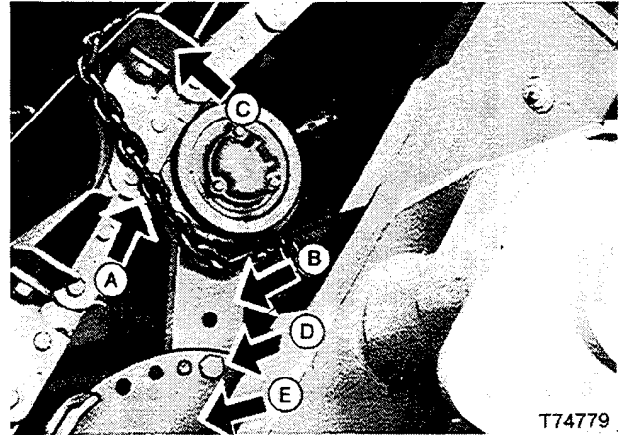

Fig. 87A-Elevator Chain

To adjust sag:

Install a chain (A) around upper adjusting idler arm (B) and flight (C).

Remove cap screw (D). If necessary, move elevator slightly to take pressure off cap screw.

Run elevator forward **VERY SLOWLY** to tighten chain part of the way.

Install cap screw.

Remove chain. Install chain around lower adjusting idler arm and flight.

Remove cap screw from lower idler arm.

Run elevator **VERY SLOWLY** in reverse to remove the rest of the sag desired.

NOTE: Upper idler plate (E) should be in the same position or one adjustment higher than lower idler plate.

Install cap screw. Remove chain.

Measure sag again. Make adjustment if necessary.

Adjust opposite side so sag varies less than 1 in. (25 mm).

18. Air Intake System (36)

Check the restriction indicator (A, Fig. 88). If the red signal can be fully seen, check the air intake system for a restriction.

Inspect clamps (B) on hoses connecting the air cleaner and the engine. Tighten the hose clamps. Inspect the hoses for cracks.

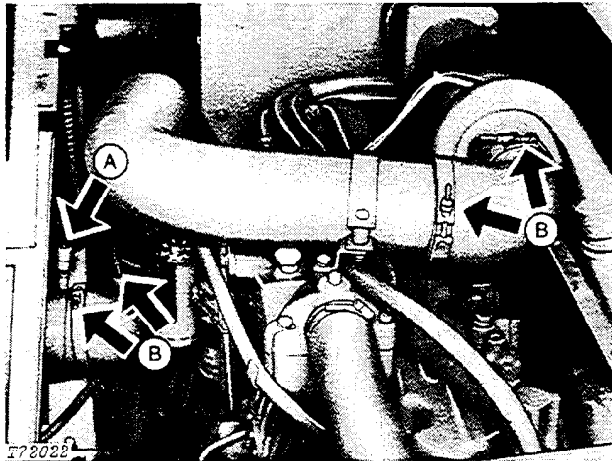

A—Restriction Indicator

B—Clamps

Fig. 88-Air Intake System

Air intake system checked

Yes No

19. Batteries

Check terminals and connections.

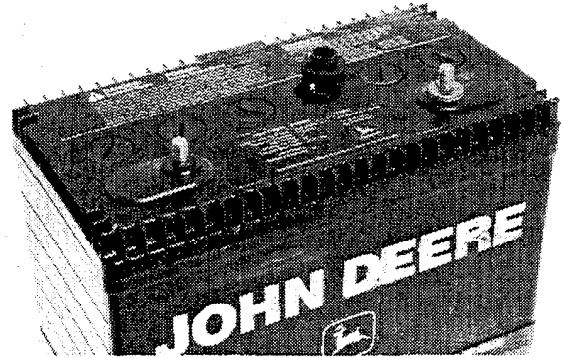

Fig. 89-Battery

If terminals are corroded, clean them with a stiff brush.

Clean batteries with a damp cloth, if necessary.

Batteries checked

Yes No



Suggest:

If the above button click is invalid.

Please download this document

first, and then click the above link

to download the complete manual.

Thank you so much for reading

20. Engine Crankcase Oil Level and Filter (29)

Check the crankcase oil level. Change the filter.

NOTE: Check with the customer if oil and filter have been changed (first 100 hours service) before doing this service.

If the oil and filter have been changed, write the information below.

Approximate hours at change:

Crankcase oil _____

Crankcase oil filter _____

If the oil and filter have not been changed, follow the procedure below:

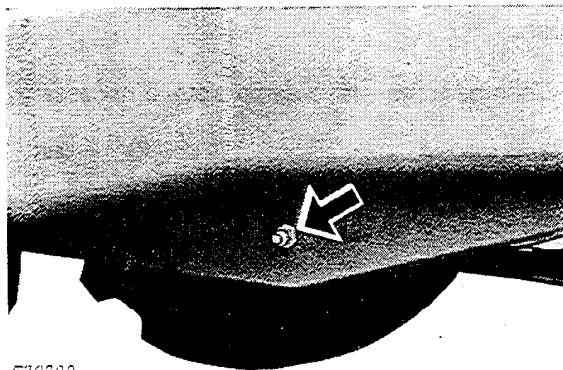

Fig. 90-Crankcase Drain Plug
 (in right side frame)

Run the engine to heat the oil. Stop the engine. Drain the oil from the crankcase. While oil is draining, change the engine oil filter.

1. Remove the pipe plug. Drain the filter. Install the plug.
2. Remove the filter. Turn it counterclockwise.

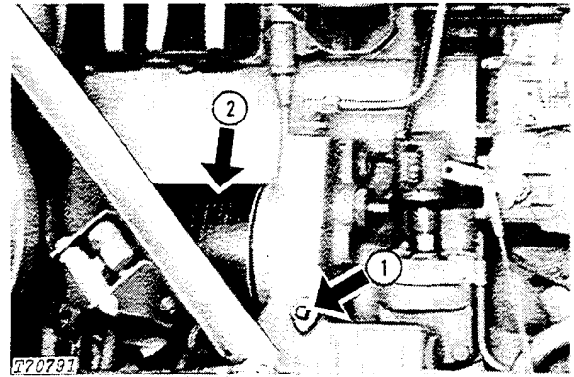

Fig. 91-Crankcase Oil Filter

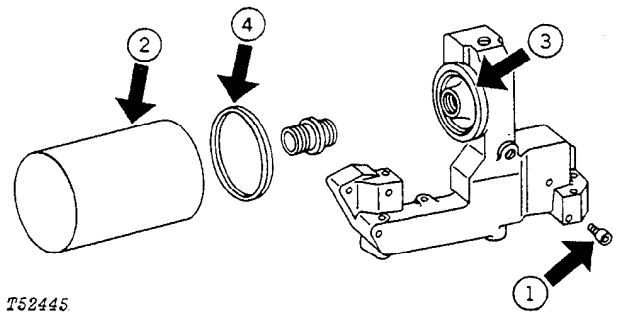

Fig. 92-Crankcase Oil Filter

3. Clean the mounting surface.
4. Apply a film of oil to the packing.
5. Tighten the new filter until it touches mounting surface.
6. Tighten 1/2 to 3/4 turn more.
7. Install the crankcase drain plug.
8. Fill the crankcase with oil specified on page I-V-4. Capacity is 29 L (31 quarts) with a filter change.

IMPORTANT: Before starting the scraper after a filter change, crank the engine for 20 seconds with the fuel shut-off handle pulled out.

9. Start the engine. Check for leaks around the filter and drain plug. Tighten only enough to stop leaks.
10. Check the oil level of the crankcase.

Oil changed	Yes	No
Filter changed	Yes	No

<https://www.ebooklibonline.com>

Hello dear friend!

Thank you very much for reading.

Enter the link into your browser.

The full manual is available for immediate download.

<https://www.ebooklibonline.com>