

John Deere JD760 Series-A Scraper

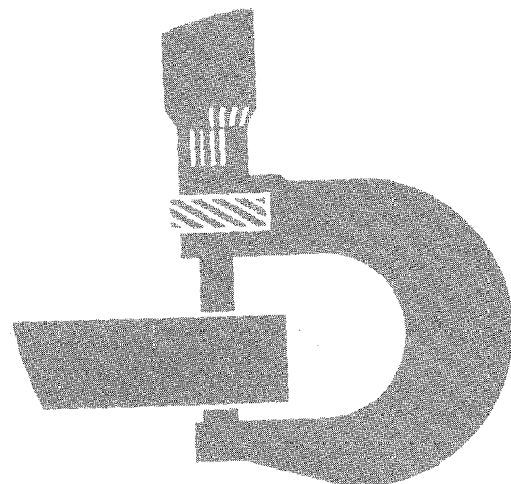

TECHNICAL MANUAL

TM-1018
Litho in U.S.A. (T) Revised

JD760 SERIES-A SCRAPER

Technical Manual TM-1018 (Jan-74)

CONTENTS

- SECTION 10 - GENERAL
- Group 5 - Specifications
 - Group 10 - Predelivery, Delivery and After-Sales Services
 - Group 15 - Tune-up and Adjustment
 - Group 20 - Lubrication
 - Group 25 - Separation
- SECTION 20 - ENGINE
- Group 5 - Basic Engine
 - Group 10 - Lubrication System
 - Group 15 - Cooling System
 - Group 20 - Speed Control Linkage
- SECTION 30 - FUEL SYSTEM
- Group 5 - Diagnosing Malfunctions
 - Group 10 - Fuel Tank, Transfer Pump, and Filters
 - Group 15 - Air Intake System
 - Group 20 - Fuel Injection Pump
- SECTION 40 - ELECTRICAL SYSTEM
- Group 5 - Information and Diagrams
 - Group 10 - Charging Circuit
 - Group 15 - Starting Circuit
 - Group 20 - Lighting and Accessory Circuits
- SECTION 50 - POWER TRAIN
- Group 5 - Transmission Disconnect Clutch
 - Group 10 - Power Shift Transmission
 - Group 15 - Differential
 - Group 20 - Final Drives
 - Group 25 - Reversible Power Take-Off
- SECTION 60 - STEERING AND BRAKES
(SEE SECTION 70)
- SECTION 70 - HYDRAULIC SYSTEM
- Group 5 - General Information, Diagnosis and Testing
 - Group 10 - Filters, Valves, Oil Cooler, and Accumulators
 - Group 15 - Hydraulic Pump
 - Group 20 - Power Steering
 - Group 25 - Power Brakes
 - Group 30 - Control Valve (Functions)
 - Group 35 - Cylinders
- SECTION 80 - MISCELLANEOUS
- Group 5 - Elevator
 - Group 10 - Drive Shafts
 - Group 15 - Draft Frame Gearbox
 - Group 20 - Elevator Gearbox
 - Group 25 - Wheels and Axle Assemblies
 - Group 30 - Bowl Components
 - Group 35 - Seat Assembly
 - Group 40 - Cab Pressurizer
- INDEX

The specifications and design information contained in this manual were correct at the time it was printed. It is John Deere's policy to continually improve and update our machines. Therefore, the specifications and design information are subject to change without notice. Wherever applicable, specifications and design information are in accordance with SAE and IEMC standards.

Copyright 1969
DEERE & COMPANY
Moline, Illinois
All rights reserved

INTRODUCTION

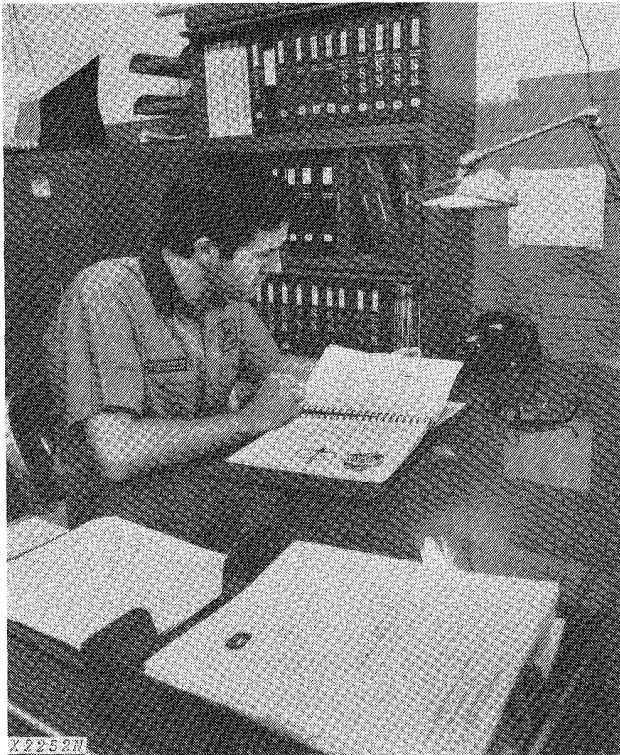

Use FOS Manuals for Reference

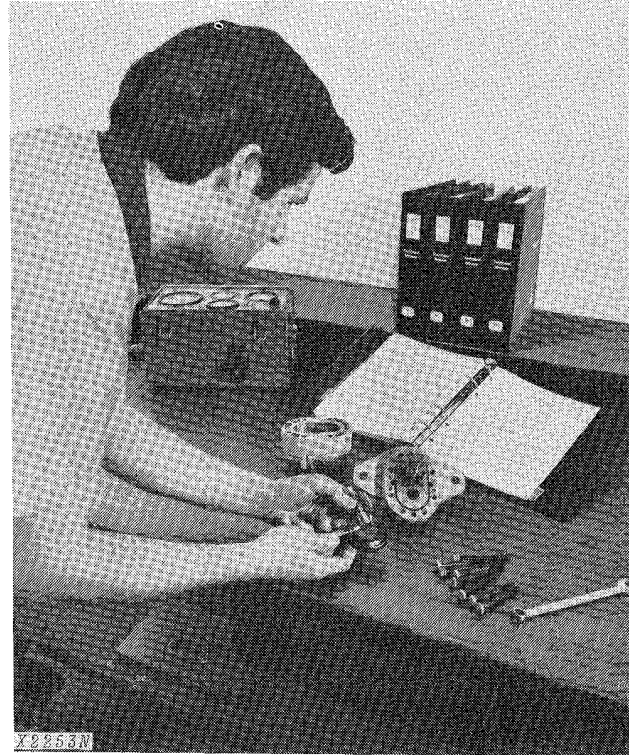

Use Technical Manuals for Actual Service

This technical manual is part of a twin concept of service:

- **FOS Manuals—**for reference
- **Technical Manuals—**for actual service

The two kinds of manuals work as a team to give you both the general background and technical details of shop service.

Fundamentals of Service (FOS) Manuals cover basic theory of operation, *fundamentals* of trouble shooting, *general* maintenance, and *basic* types of failures and their causes. FOS Manuals are for training new men and for reference by experienced men.

Technical Manuals are concise service guides for a *specific* machine. Technical Manuals are on-the-job guides containing only the vital information needed by a journeyman mechanic.



When a serviceman should refer to a FOS Manual for more information, a FOS symbol like the one at the left is used in the TM to identify the reference.

Some features of this technical manual:

- *Table of contents at front of manual*
- *Exploded views showing parts relationship*
- *Photos showing service techniques*
- *Specifications grouped for easy reference*

This technical manual was planned and written for you—a journeyman mechanic. Keep it in a permanent binder in the shop where it is handy. Refer to it whenever in doubt about correct service procedures or specifications.

Using the technical manual as a guide will reduce error and costly delay. It will also assure you the best in finished service work.



This safety alert symbol identifies important safety messages in this manual. When you see this symbol, be alert to the possibility of personal injury and carefully read the message that follows.

<https://www.ebooklibonline.com>

Hello dear friend!

Thank you very much for reading.

Enter the link into your browser.

The full manual is available for immediate download.

<https://www.ebooklibonline.com>

**COMPLETE PAGE LISTING
 WITH LATEST DATE LINES**

1, 2	(Jan-74)	40-5-21, 22	(Feb-75)
3, 4	(Oct-80)	40-10-1, 2	(May-70)
		40-10-3, 4	(Apr-74)
10-5-1, 2	(Feb-75)	40-10-5, 6	(May-70)
10-5-3, 4	(May-73)	40-10-7, 8	(Feb-75)
10-10-1, 2	(Apr-71)	40-10-9, 10	(Feb-73)
10-10-3, 4	(Apr-74)	40-15-1, 2	(Feb-73)
10-10-5, 6	(May-70)	40-15-3, 4	(Oct-80)
10-15-1, 2	(May-73)	40-15-5, 6	(Oct-80)
10-20-1, 2	(Feb-73)	40-15-7, 8	(Feb-73)
10-25-1, 2	(Feb-75)	40-15-9, 10	(Feb-73)
10-25-3, 4	(Feb-75)	40-15-11, 12	(Oct-80)
10-25-5, 6	(Feb-73)	40-15-13, 14	(Apr-74)
10-25-7, 8	(Feb-73)	40-15-15, 16	(May-73)
10-25-9, 10	(Feb-73)	40-15-17, 18	(Feb-73)
10-25-11, 12	(Feb-73)	40-20-1, 2	(May-70)
		40-20-3, 4	(Feb-75)
20-5-1, 2	(Nov-72)		
20-5-3, 4	(Nov-73)	50-5-1, 2	(Oct-80)
20-5-5, 6	(Nov-73)	50-5-3, 4	(Oct-80)
20-5-7, 8	(Oct-80)	50-5-5, 6	(Oct-80)
20-5-9, 10	(Feb-75)	50-10-1, 2	(May-70)
20-5-11, 12	(Feb-75)	50-10-3, 4	(May-70)
20-5-13, 14	(Jan-74)	50-10-5, 6	(Feb-73)
20-5-15, 16	(Nov-73)	50-10-7, 8	(Feb-73)
20-5-17, 18	(Feb-75)	50-10-9, 10	(Feb-75)
20-10-1, 2	(Apr-71)	50-10-11, 12	(Feb-73)
20-10-3, 4	(Apr-71)	50-10-13, 14	(Feb-73)
20-10-5, 6	(May-70)	50-10-15, 16	(Feb-73)
20-15-1, 2	(May-70)	50-10-17, 18	(Oct-80)
20-15-3, 4	(May-70)	50-10-19, 20	(Oct-80)
20-20-1, 2	(May-70)	50-10-21, 22	(Oct-80)
		50-10-23, 24	(Oct-80)
30-5-1, 2	(Apr-71)	50-10-25, 26	(Oct-80)
30-10-1, 2	(May-73)	50-10-27, 28	(Feb-75)
30-10-3, 4	(Apr-71)	50-10-29, 30	(Oct-80)
30-15-1, 2	(Apr-71)	50-10-31, 32	(Oct-80)
30-20-1, 2	(Oct-80)	50-10-33, 34	(Feb-75)
30-20-3, 4	(Nov-72)	50-10-35, 36	(Nov-73)
		50-10-37, 38	(Nov-73)
40-5-1, 2	(Feb-75)	50-15-1, 2	(Oct-80)
40-5-3, 4	(Nov-72)	50-15-3, 4	(Oct-80)
40-5-5, 6	(Feb-75)	50-15-5, 6	(Nov-73)
40-5-7, 8	(Nov-72)	50-20-1, 2	(Oct-80)
40-5-9, 10	(Feb-75)	50-25-1, 2	(Apr-71)
40-5-11, 12	(Feb-75)	50-25-3, 4	(Oct-80)
40-5-13, 14	(Jan-74)		
40-5-15, 16	(Feb-75)	60-5-1, 2	(May-70)
40-5-17, 18	(Feb-75)		
40-5-19, 20	(Feb-75)		

| Vertical lines indicate pages included in this revision.

70-5-1, 2	(Jul-74)	Index 1, 2	(May-73)
70-5-3, 4	(Jul-74)	Index 3, 4	(May-73)
70-5-5, 6	(Jul-74)	Index 5, 6	(May-73)
70-5-7, 8	(Jul-74)		
70-10-1, 2	(May-70)		
70-10-3, 4	(Apr-74)		
70-10-5, 6	(Oct-80)		
70-10-7, 8	(Apr-74)		
70-15-1, 2	(Nov-72)		
70-15-3, 4	(Oct-80)		
70-15-5, 6	(Oct-80)		
70-15-7, 8	(Jul-74)		
70-20-1, 2	(Nov-73)		
70-20-3, 4	(Nov-73)		
70-20-5, 6	(May-70)		
70-20-7, 8	(May-73)		
70-20-9,10	(Nov-73)		
70-20-11, 12	(Nov-73)		
70-20-13, 14	(Nov-73)		
70-20-15, 16	(Nov-73)		
70-20-17, 18	(Nov-73)		
70-25-1, 2	(May-70)		
70-25-3, 4	(May-70)		
70-25-5, 6	(May-70)		
70-25-7, 8	(Feb-75)		
70-25-9, 10	(Jul-74)		
70-25-11, 12	(Jul-74)		
70-25-13, 14	(Jul-74)		
70-25-15, 16	(Jul-74)		
70-30-1, 2	(Oct-80)		
70-30-3, 4	(Feb-75)		
70-30-5, 6	(Feb-75)		
70-35-1, 2	(May-70)		
70-35-3, 4	(Aug-73)		
80-5-1, 2	(Feb-75)		
80-5-3, 4	(Nov-72)		
80-5-5, 6	(Jan-74)		
80-5-7, 8	(Feb-75)		
80-10-1, 2	(Apr-71)		
80-15-1, 2	(May-70)		
80-20-1, 2	(May-70)		
80-25-1, 2	(May-70)		
80-25-3, 4	(May-70)		
80-25-5, 6	(Apr-71)		
80-30-1, 2	(May-73)		
80-30-3, 4	(May-73)		
80-35-1, 2	(Apr-71)		
80-35-3, 4	(Nov-72)		
80-35-5, 6	(Nov-72)		
80-40-1, 2	(Apr-71)		

| Vertical lines indicate pages included in this revision.

Section 10 GENERAL

CONTENTS OF THIS SECTION

	Page		Page
GROUP 5 - SPECIFICATIONS		GROUP 20 - LUBRICATION	
Machine Specifications	5-1	General Information	20-1
Dimensions	5-3	Lubrication Chart	20-1
Serial Numbers	5-4	Lubricants	20-2
GROUP 10 - PREDELIVERY, DELIVERY, AND AFTER-SALE SERVICES		GROUP 25 - SEPARATION	
Predelivery Service	10-1	Removing and Installing	
Delivery Services	10-3	Operator's Station	25-1
After-Sale Services	10-4	Engine	25-4
 		Clutch Housing	25-6
GROUP 15 - TUNE-UP AND ADJUSTMENT		Transmission	25-9
Preliminary Engine Testing	15-1	Scraper	25-10
Engine Tune-Up	15-1	Rear Axle Housing Assembly	25-11
Tractor Tune-Up	15-2	Specifications	25-12

Group 5 SPECIFICATIONS

Horsepower (at 2200 rpm)
 Net engine flywheel (at 500 ft. altitude
 and 85°F. temperature) 152

Engine
 Type Diesel, 6-cylinder, in-line,
 valve-in-head 4 stroke-cycle
 Bore and stroke 4-3/4 in. x 5 in.
 Displacement 531 cu. in.
 Compression ratio 16.5 to 1
 Firing order 1-5-3-6-2-4

Fuel System
 Type Direct injection
 Injection pump Inlet metering
 distributor-type

Cooling System
 Type Pressurized with centrifugal pump
 Engine temperature control 2 thermostats

Engine Lubricating System Force feed,
 pressurized, with full flow oil filter

Electrical System
 Type 12-volt with 55 amp. alternator and
 transistorized regulator
 Batteries two 6-volt, group 7D, tractor type,
 connected in series

Hydraulic System
 Type Closed-center, constant pressure,
 includes power steering, power
 brakes, scarifier and scraper functions

Steering
 Type Full power, hydrostatic type,
 provision for manual operation

Service Brakes
 Tractor Foot operated, wet-disk type,
 hydraulically actuated
 Tractor Hand emergency, hydraulically
 actuated shoe type
 Scraper Hand-lever or foot-operated,
 hydraulically actuated shoe type

DIMENSIONS

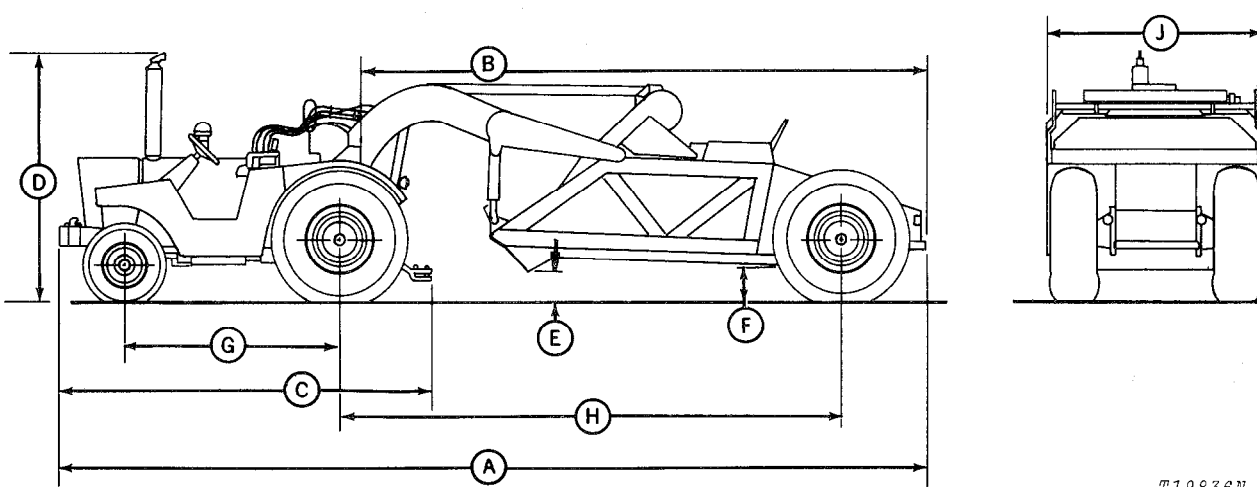

T19836N

Fig. 1-JD760 Series-A Scraper Dimensions

	<u>Bowl Up</u>	<u>Bowl Down</u>
A. Overall Length	32 ft. 10-1/2 in.	33 ft. 7-1/2 in.
B. Scraper Length (to Swivel)	21 ft. 8-1/4 in.	22 ft. 3-1/4 in.
C. Overall Tractor Length	13 ft. 1-1/2 in.	13 ft. 1-1/2 in.
D. Overall Height	9 ft. 1-1/4 in.	9 ft. 1-1/4 in.
E. Blade Above Ground (Center Blade, Extended)	17-3/4 in.
F. Clearance, Rear Frame - Minimum	16-1/4 in.	13-1/2 in.
G. Tractor Wheel Base	7 ft. 11-1/2 in.	7 ft. 11-1/2 in.
H. Scraper Wheel Base	18 ft. 7-1/8 in.	19 ft. 4-3/4 in.
J. Maximum Width	8 ft.	8 ft.

The specifications and design information contained in this manual were correct at the time this machine was manufactured. It is John Deere's policy to continually improve and update our machines. Therefore the specifications and design information are subject to change without notice. Wherever applicable, specifications and design information are in accordance with SAE and IEMC standards.

SERIAL NUMBERS

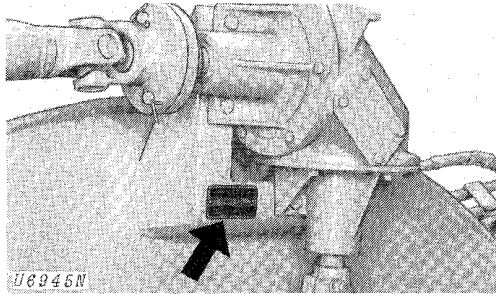

Fig. 2-Scraper Serial Number

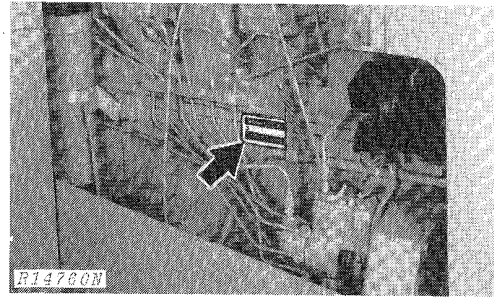

Fig. 4-Engine Serial Number (Early Units)

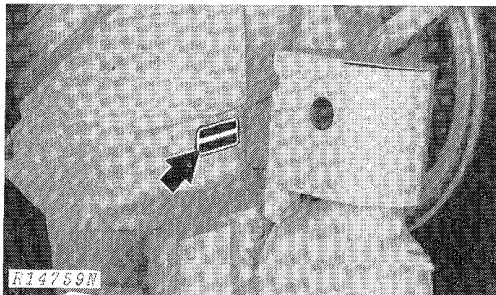

Fig. 3-Tractor Serial Number

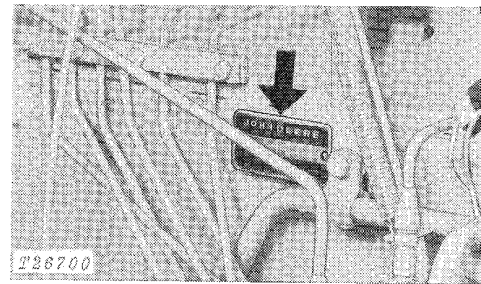

Fig. 5-Engine Serial Number (Later Units)

Group 10

PREDELIVERY, DELIVERY, AND AFTER-SALES SERVICES

PREDELIVERY SERVICE

Every new John Deere scraper leaves the factory so it can be delivered to the customer after a minimum of servicing.

Shipping factors, in addition to extra finishing touches needed for customer satisfaction, necessitate proper predelivery service on the part of the dealer.

A tag pointing out the factory-recommended procedure for predelivery service is attached to every new scraper before it leaves the factory.

After completing the factory-recommended checks and services listed on the predelivery tag, remove and file the tag with the job shop order. The tag and the customer's John Deere Delivery Receipt certify proper predelivery service when that section of his receipt is completed.

TEMPORARY MACHINE STORAGE

Service	Specifications	Reference
Check radiator for coolant loss and antifreeze protection.	Level with baffle in top of radiator.
Relieve hydraulic pressure.	Stop engine, lower scraper bowl and scarifier and operate cylinders to relieve pressure.
Reduce shipping pressure of tires.	Operator's Manual

BEFORE DELIVERING MACHINE

<p>ELECTRICAL SYSTEM</p> <p>Check battery terminals to be sure they are tight.</p>	<p>.....</p>	<p>Operator's Manual</p>
<p>COOLING SYSTEM</p> <p>Inspect radiator for coolant loss.</p> <p>Check antifreeze protection.</p>	<p>Level with baffle in top of radiator.</p> <p>.....</p>	<p>.....</p>
<p>TIRES AND WHEELS</p> <p>Adjust pressure of tires.</p> <p>Check tractor front wheel hub bolts, rear tractor wheel rim nuts, rear tractor wheel retainer cap screws, and scraper rim nuts for tightness.</p>	<p>.....</p> <p>Tractor front hub bolts - 275 ft-lbs Rear tractor rim nuts - 400 ft-lbs Tractor wheel retainer cap screws - 300 ft-lbs Scraper rim nuts - 400 ft-lbs</p>	<p>Operator's Manual</p> <p>.....</p>

BEFORE DELIVERING MACHINE—Continued

Service	Specifications	Reference
LUBRICATION		
Check crankcase oil level.	To upper marks on dipstick.	Operator's Manual.
Check transmission-hydraulic system oil level.	To top of "SAFE" range on dipstick. Type 303 Special-Purpose Oil.	Operator's Manual
Check draft frame gearbox and elevator gearbox oil levels.	Operator's Manual
Check hydraulic cylinder operations.	Operator's Manual
Lubricate grease fittings.	John Deere Multi-Purpose lubricant or an equivalent.	Operator's Manual
ENGINE		
Check air cleaner.	Operator's Manual
Fill fuel tank and start engine.	Operator's Manual
Check operation of lights, gauges, and indicator lamps.	Operator's Manual
Check engine idle speeds.	2400 rpm fast idle speed, 2200 load speed, 800 rpm slow idle speed.
OPERATION		
Check engine disconnect clutch.	No tendency for tractor to creep when clutch is disengaged.	Operator's Manual
Shift transmission through all speeds.	Operator's Manual
Check transmission disconnect clutch operation.	Clutch pedal free travel should be 2-1/4 inch average.	Operator's Manual
Check power-takeoff operation.	Operator's Manual
Check differential lock operation.	Operator's Manual

BEFORE DELIVERING MACHINE—Continued

Service	Specifications	Reference
Check steering, brakes, and hydraulic operations.	Operator's Manual
Check seat operation.	Operator's Manual
GENERAL		
Tighten accessible nuts and cap screws.	Operator's Manual
Clean scraper and touch up paint.
Install seat belts, if necessary.	Instructions with seat belts.

DELIVERY SERVICE

A thorough discussion of the operation and service of a new machine at the time of delivery helps to assure complete customer satisfaction. Proper delivery should be an important phase of a dealer's program. One section of the John Deere Delivery Receipt emphasizes the importance of proper delivery service.

Complaints may arise if the owner is not shown how to operate and service his new machine correctly. Devote enough time, at your customer's convenience, to introduce him to his new machine. Explain fully how to operate and service it.

The following procedure is recommended before the serviceman and owner complete the delivery acknowledgments section of the Delivery Receipt.

Using the operator's manual as a guide, make sure the owner thoroughly understands the following points:

1. Operation and use of controls and instruments.
2. Operation of the engine.
3. Importance of the break-in period.
4. Use of liquid or cast-iron ballast.
5. Operation and functions of the hydraulic system.
6. Operation and use of the PTO and drive.
7. Importance of safety.
8. Importance of lubrication and periodic services.

After explaining and demonstrating the above points, have the owner sign the Delivery Receipt and give him his operator's manual.

AFTER-SALES INSPECTION

The purchaser of a new John Deere machine is entitled to a free inspection at some mutually agreeable time within the warranty period after the equipment has been "run in." The terms of this after-sales inspection are outlined on the back of the customer's John Deere Delivery Receipt.

The purpose of this inspection is to ensure that the customer is receiving satisfactory performance from his machine. At the same time, the inspection should reveal whether or not the machine is being operated, lubricated, and serviced properly.

If the recommended after-sales service inspection is followed, the dealer can eliminate minor irregularities which can develop into major service problems at a later date. This will promote strong dealer-customer relations and give the dealer an opportunity to answer questions that may have arisen during the initial operation.

During the inspection service, the dealer has the opportunity to promote the sale of additional new equipment and accessories.

INSPECTION PROCEDURES

Service	Specifications	Reference
Check radiator coolant level.	Level with baffle in top of radiator.
Clean external surface of radiator core.
Check hoses and connections for leaks.

FUEL SYSTEM

Remove water and foreign matter from fuel pump and filter sediment bowls.	Operator's Manual
Bleed fuel system.	Operator's Manual
Tighten loose connections and check entire system for leaks. Correct if necessary.
Check air cleaner element and clean, if necessary.	Operator's Manual

ELECTRICAL SYSTEM

Check specific gravity and electrolyte level of batteries.	Full charge - 1.260 at 80°F.
Check belt tension.	Operator's Manual
Start engine and check action of starter, lights, and indicator lamps.	Operator's Manual

LUBRICATION

Check engine crankcase oil level.	To upper marks on dipstick.	Operator's Manual
Check transmission-hydraulic system oil level.	In "SAFE" range on dipstick. Use John Deere Type 303 Special-Purpose Oil.	Operator's Manual
Check draft frame gearbox and elevator gearbox oil levels.	Operator's Manual

ENGINE

Check valve clearance.	Section 20, Group 5
Check engine speed under load, fuel consumption, and horsepower.

AFTER-SALES INSPECTION—Continued

Service	Specifications	Reference
CLUTCHES AND DIFFERENTIAL LOCK		
Check transmission disconnect clutch operation.	Clutch pedal free travel should be 2-1/4 inch average.	Operator's Manual
Check transmission inching pedal for smooth operation.	Operator's Manual
Shift transmission through all speeds.
Check engine disconnect clutch.	No tendency for tractor to creep when clutch is disengaged.	Operator's Manual
Check PTO clutch, brake, and reversing operations.	Operator's Manual
Check differential lock operation.	Operator's Manual
HYDRAULIC SYSTEM		
Check hydraulic cylinder operations, fittings, and hose positions.	Operator's Manual
Check power steering.	Smooth, easy operation.
Check power brakes and accumulator.	With engine stopped, brakes must be solid and pedal travel should not exceed 3 inches for 20 applications.	Operator's Manual
SCRAPER		
Check scraper chain adjustment.	Operator's Manual
Check scraper operations.	Operator's Manual
Check for uneven bowl filling.	Operator's Manual
Check for cutting edge wear.	Operator's Manual
NUTS AND CAP SCREWS		
Tighten accessible nuts and cap screws	Group 25

Group 15

TUNE-UP AND ADJUSTMENT

GENERAL INFORMATION

Before tuning up a scraper, determine whether a tune-up will restore operating efficiency. When there is doubt, the following preliminary tests will help to determine if the engine can be tuned up. If the condition is satisfactory, proceed with the tune-up. Choose from the following procedures only those necessary to restore the unit.

PRELIMINARY ENGINE TESTING

Operation	Specification	Reference
Cylinder compression	425 psi minimum, 50 psi maximum variation between cylinders	Section 20, Group 5
Check radiator for air bubbles and presence of oil

ENGINE TUNE-UP

AIR INTAKE SYSTEM

Service air cleaner and check system for leaks	Section 30, Group 15
Check system for restrictions using water manometer (inches of water)	9-10 in. water and clean element; 25 in. max. permitted reading (full load - 2200 rpm)	Section 30, Group 15
Restriction indicator	24-26 in. water	Section 30, Group 15
Check crankcase breather for restrictions
Check exhaust system for restriction
Retighten cylinder head cap screws	180 ft-lbs in sequence	Section 20, Group 5
Check valve clearance	Intake 0.018 in. Exhaust 0.028 in.	Section 20, Group 5

ENGINE LUBRICATION SYSTEM

Check engine oil pressure	25-35 psi (1900 rpm)	Section 20, Group 10
---------------------------	----------------------	----------------------

FUEL SYSTEM

Check fuel tank and lines for leaks and restrictions
Clean sediment bowls and change filter	Section 30, Group 10
Service injection nozzles	SM-2045
Service injection pump and check timing	2° advance at 1300 rpm (no load); 5° advance by 2500 rpm (no load); 4° advance at 1900 rpm (full load)	Section 30, Group 20
Adjust speed control linkage and check engine speeds

ENGINE TUNE-UP - Continued

Operation	Specification	Reference
ELECTRICAL SYSTEM		
Batteries		
Check electrolyte level	Fill to bottom ring of each cell
Check battery specific gravity	1.240-1.260 at 80° F
Clean battery cables and box
Check alternator belts tension	1-inch belt deflection with 20 in-lb force
Check operation of alternator, air cleaner, oil pressure, and transmission filter restriction
indicator lights	Section 40, Group 20
Check alternator output	With Regulator (80° F) Minimum at 1660 rpm (800 engine rpm) 28 amps at 13.0 volts Minimum at 3000 alternator rpm (1443 engine rpm) 40-45 amps at 13.5 volts	Section 40, Group 10
Check alternator regulated voltage	14.2-14.6 volts at 80° F (operating)	Section 40, Group 10
Check starter safety switch operation	Voltage drop 0.1 volt maximum	Section 40, Group 15
SPEED CONTROL LINKAGE		
Adjust linkage	Foot-2400 rpm fast idle speed, 2200 rpm load speed Hand-2400 rpm fast idle speed, 2200 rpm load speed, 800 rpm slow idle speed	Section 20, Group 20

TRACTOR TUNE-UP

Check transmission disconnect pedal operation	Tractor should not creep when clutch is disengaged (2-1/4-inch average free travel)	
Transmission:		
Pump pressure	165 - 185 psi at 1900 rpm and 100° F.	Section 50, Group 10
Engaged element pressure	Max. of 15 psi less than pump	Section 50, Group 10
Check differential lock operation (engaged)	420 - 480 psi	Section 50, Group 15
Check brake pedal travel and even position of pedals against treadle	3 inches maximum pedal travel for 20 applications (each brake pedal) at 5 second intervals	Section 70, Group 25
Check front wheel bearing adjustment and lubrication	35 ft-lbs, loosen to hole	Section 80, Group 25
Check front wheel toe-in	1/8 - 3/8 in. less than rear	Section 80, Group 25
Transmission pump	12.5 gpm minimum at 1900 rpm at 165-185 psi	Section 70, Group 5
	2300 - 2400 psi (standby)	Section 70, Group 5
Main hydraulic pump	22 gpm at 2000 psi and 1900 rpm	Section 70, Group 5
Pressure control valve	1800-1850 psi at 800 rpm	

Group 20 LUBRICATION

GENERAL INFORMATION

Carefully written and illustrated lubrication instructions are given in the operator's manual furnished with your customer's machine. Remind him to follow these instructions carefully.

For your convenience when servicing the scraper the following chart shows service intervals, capacities and types of lubricant for each of the components and systems. A definition of lubricants follows the chart.

LUBRICATION CHART

Component	Capacity	Type of Lubricant	Interval of Service
Engine crankcase	20 U.S. quarts (includes filter)	See "Engine Lubricating Oil" on page 20-2	10 Hours - Check level 100 Hours - Change oil 200 Hours - Replace filter
Transmission and hydraulic system	24 U.S. gallons	John Deere Type 303 Special-Purpose Oil	10-Hours - Check level 500 Hours - Replace filters 1000 Hours - Change oil
Grease fittings	As required	John Deere Multi-Purpose Lubricant or an equivalent	See operator's manual
Chain	As required	Same as engine oil	10 Hours - Lubricate links
Draft frame and elevator gear box	To level of filler plug	SAE 140 EP Oil	As required - Check oil level 1000 Hours - Drain and refill
Tractor front and rear wheel bearings	As required	Wheel bearing grease	1000 Hours - Clean, repack and adjust
Scraper wheel bearings	As required	Wheel bearing grease	1000 Hours - Clean, repack and adjust
Side rails	As required	Waste oil	As required
Front wheel bearings	As required	John Deere Multi-Purpose Lubricant or an equivalent	10-Hours-only when operating in extremely wet and muddy conditions

Effective use of lubricating oils and greases is perhaps the most important step towards low upkeep cost, long machine life, and satisfactory service. Use only lubricants specified in this section; apply them at the intervals and according to instructions in the lubrication section.

ENGINE LUBRICATING OILS



We recommend John Deere Torq-Gard or Torq-Gard Supreme engine oil for use in the engine crankcase. This oil was compounded specifically for use in John Deere engines, and provides superior lubrication under all conditions. NEVER PUT ADDITIVES IN THE CRANKCASE. Torq-Gard oil was formulated to provide all the protection your engine needs. Additives could reduce this protection rather than help it.

If oil other than Torq-Gard or Torq-Gard Supreme is used, it must conform to one of the following specifications for all John Deere engines:

SINGLE VISCOSITY OILS

API Service CD/SD
MIL-L-2104C
Series 3

MULTI-VISCOSITY OILS

API Service CC/SD
MIL-L-46152

Depending on the expected prevailing temperature for the fill period, use oil of viscosity as shown in the following chart.

Air Temperature	John Deere Torq-Gard Oil	Other Oils	
		Single-Viscosity Oil	Multi-Viscosity Oil
Above 32°F.	SAE 30	SAE 30	Not recommended.
-10°F. to 32°F.*	SAE 10W-20	SAE 10W	SAE 10W-30
Below -10°F.	SAE 5W-20	SAE 5W	SAE 5W-20

* SAE 5W-20 oil may also be used to insure optimum lubrication at starting, particularly when engine is subjected to $-10^{\circ}F.$ or lower temperatures for several hours.

Some increase in oil consumption may be expected when SAE 5W-20 or SAE 5W oils are used. Check oil level more frequently.

TRANSMISSION HYDRAULIC OILS

Use only John Deere Type 303 Special-Purpose Oil or its equivalent in the transmission-hydraulic system. Other types of oil will not give satisfactory service, and may result in eventual damage. This special oil, available from your John Deere dealer, may be used in all weather conditions.

GREASES

Use John Deere Multi-Purpose Lubricant or an equivalent SAE multipurpose-type grease for all grease fittings. Wheel bearing grease is recommended for rear axle bearings and for front wheel bearings. Application of grease as instructed in the lubrication section will provide proper lubrication and will keep contamination out of bearings.

STORING LUBRICANTS

Your scraper can operate at top efficiency only if clean lubricants are used. Use clean containers to handle all lubricants. Store them in an area protected from dust, moisture, and other contamination.

Group 25 SEPARATION

REMOVING AND INSTALLING OPERATOR'S STATION

Remove left rear fender.

Disconnect line from emergency brake cylinder and from tee on panel in front of left rear fender. Remove line.

Loosen left-hand service brake bleed screw and depress brake pedal to discharge accumulator.

Remove muffler and hood.

Drain the engine cooling system.

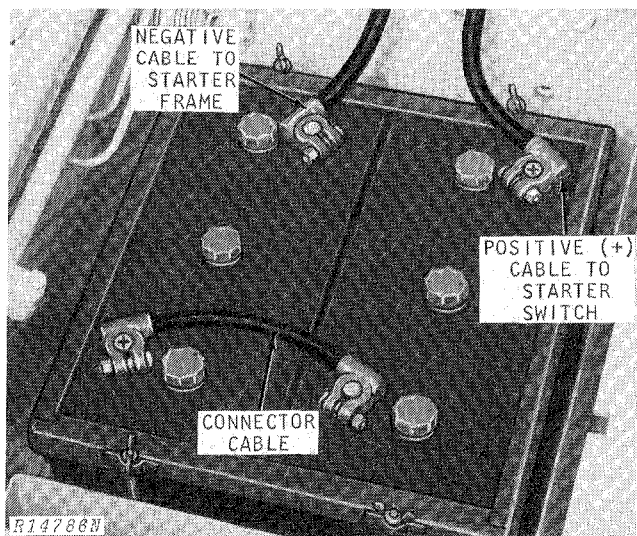

Fig. 1-Battery Connections

Remove seat.

Remove battery door.

Disconnect cables and remove batteries (Fig. 1). Remove battery cables from operator's station.

Disconnect tachometer cable, heat indicator tube, and steering lines (Fig. 2).

Remove disconnect clutch pedal and left-hand engine cover.

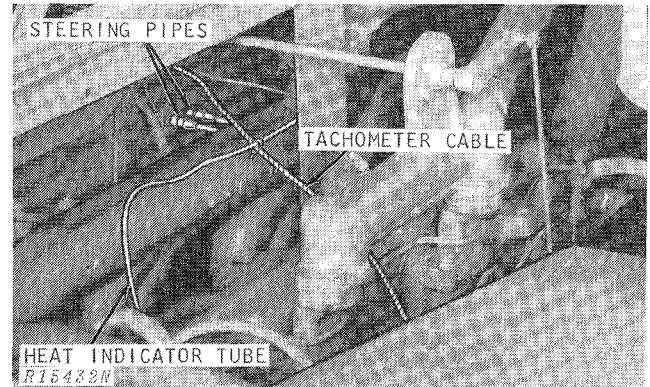

Fig. 2-Steering Lines, Tachometer Cable, and Heat Indicator Tube

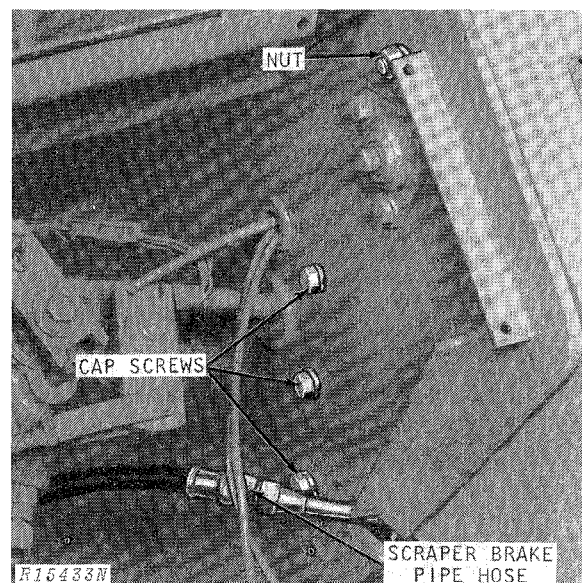

Fig. 3-Scraper Brake Hose, Cap Screws, and Nut
(Instrument Panel Removed for Illustration Purposes)

Remove lower instrument panel cover. Disconnect hose from scraper brake line and remove cap screws and nut securing upper station to control support (Fig. 3).

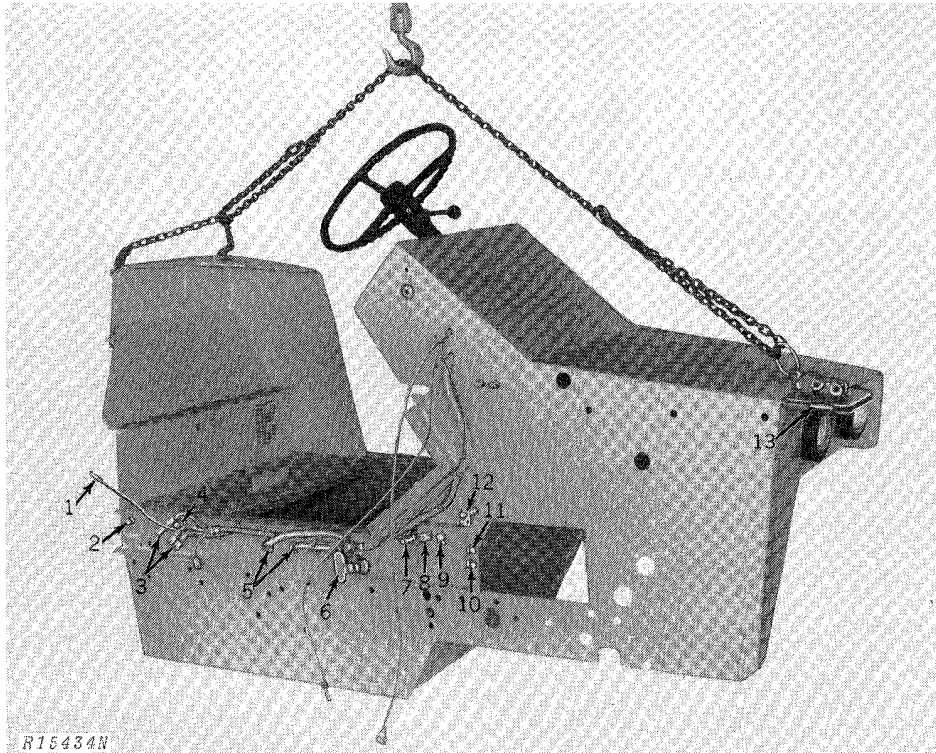
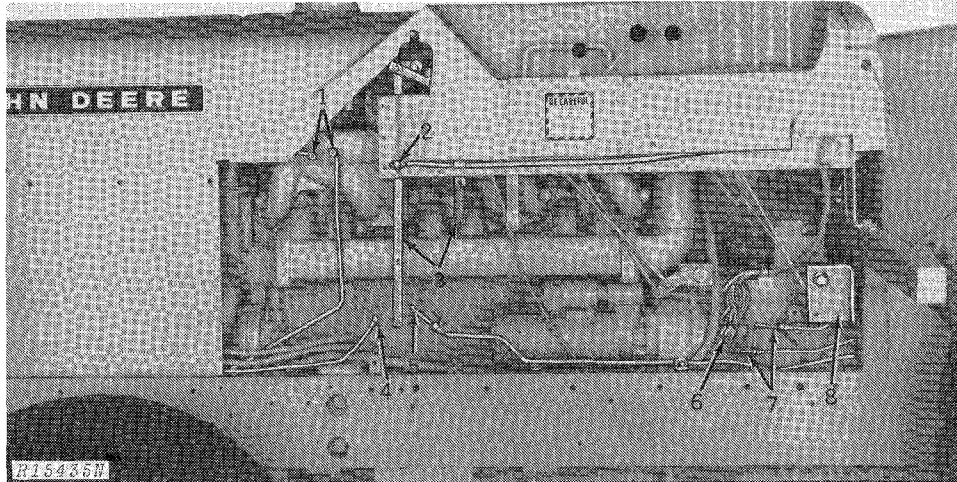

Fig. 4-Operator's Station Connections

NOTE: Keys 1-12 shown in Fig. 4 correspond to Steps 1-12 below.

1. Disconnect transmission heat indicator bulb from transmission pressure regulating housing (Fig. 4).
2. Disconnect differential lock pressure line from operator's station.
3. Disconnect wiring harness. (It may be necessary to disconnect inching pedal operating rod, step 6, before wiring harness.)
4. Disconnect right- and left-hand brake lines.
5. Disconnect battery cables from starter.
6. Disconnect inching pedal operating rod.

7. Remove retaining ring from foot throttle. Disconnect foot throttle link and return spring (3, Fig. 5).
8. Disconnect hydraulic oil return hose from junction block.
9. Remove junction block panel and disconnect priority valve bleed line.
10. Disconnect priority valve pressure line from junction block.
11. Disconnect brake accumulator pressure line from junction block.
12. Disconnect clamp securing left-hand steering line to station.



- 1-Steering Lines
- 2-Scraper Brake Line
- 3-Foot Throttle Link and Spring
- 4-Priority Valve Bleed Line

- 5-Junction Block Hydraulic Oil Return Line
- 6-Wiring Harness
- 7-Brake Lines
- 8-Disconnect Pedal Support Bracket

Fig. 5-Tractor with Station Removed

Install lift bracket (13, Fig. 4 and Fig. 18), chains, and hoist.

Remove cap screws securing disconnect pedal support bracket to station.

Remove brace rod between operator's station and upper hood and dash support.

Disconnect wire from transmission oil light at connection near brace rod.

Remove clamps securing hydraulic return oil line to frame. Raise line over inching pedal lever.

Remove cap screws securing operator's station to side frame and main support and remove station.

Assembly

Attach operator's station to side frame and main support.

Connect brace rod between station and upper hood and dash support.

Install hydraulic return oil line.

Install disconnect pedal support bracket.

Remove hoist, chains, and lift bracket.

Reverse removal procedures 1 through 12 (page 25-2).

Secure upper station to control support with cap screws and nut.

Connect scraper brake line hose and install lower instrument panel cover.

Install left-hand engine cover and disconnect clutch pedal.

Install battery door.

Install seat.

Install tachometer cable, heat indicator tube, and steering lines.

Fill the engine cooling system and install hood and muffler.

Install left rear fender.

Start the engine, check for leaks and bleed the service brakes and emergency brakes.

REMOVING AND INSTALLING ENGINE

Remove scraper as described on page 10-25-10.

Remove muffler, hood, right-hand engine shield, front bumper cover, and front grille.

Disconnect batteries (Fig. 1). Discharge brake accumulator.

Remove hose clamps and disconnect hoses from brake accumulator. Remove molded hose from top of main pump to bottom tank of oil cooler and line from top tank of oil cooler to fitting of main pump.

Disconnect horn wires and right-hand steering line from fitting on grille housing. Remove steering line clamps.

Remove lower dust cover and front bumper.

Disconnect upper hood and dash support and radiator tie rods from grille housing. Remove cap screws securing grille housing to frames, slide housing forward, attach chain and lift housing from tractor (oil cooler and accumulator go with grille housing).

IMPORTANT: Set grille housing on wood blocks to prevent damage to lower tank of oil cooler.

Remove disconnect clutch pedal and left-hand engine cover.

Drain the cooling system.

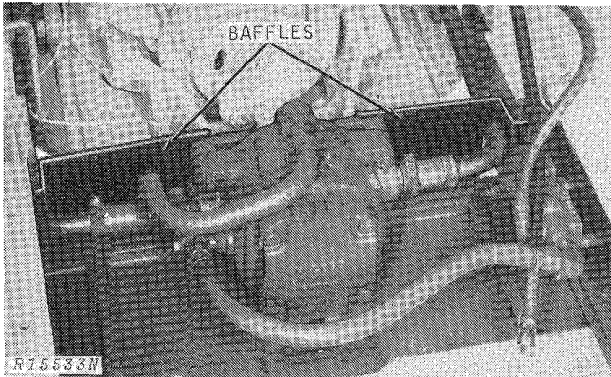

Fig. 6-Radiator Baffles

1. Remove upper and lower radiator hoses. Loosen radiator, tilt forward, and remove engine fan, then radiator. Remove baffles (Fig. 6).

2. Disconnect hydraulic pump hoses. Remove hydraulic pump drive coupler, hydraulic pump, and pump support. Disconnect oil seal bleed tube after sliding pump forward.

3. Disconnect hydraulic line at main pump and connection near starter. Remove line. (Line runs along left side of engine over engine mounting points.)

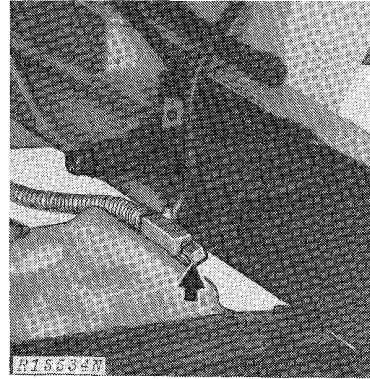

Fig. 7-Steering Line Junction Block Fitting

4. Remove right- and left-hand steering lines. (Turn front fitting to the left-hand steering line junction block down 90° to prevent interference with pressure control valve fitting) (Fig. 7).

5. Remove exhaust manifold extension.

6. Disconnect speed control rod from injection pump. Move speed control shaft outward, and disconnect hand throttle link and foot throttle link.

7. Remove water bypass line, water manifold, and thermostats.

8. Remove crankcase breather pipe.

9. Disconnect tachometer drive cable, heat indicator tube, ether starting aid line, and fuel leakoff hose from engine.

10. Remove engine air intake pipe.

11. Disconnect oil pressure sender. Close fuel shut-off valve and remove fuel line to fuel pump.

12. Disconnect wiring harness from alternator, injection pump, and oil pressure indicator lamp switch.

13. Disconnect wiring harness and battery cables from starter.

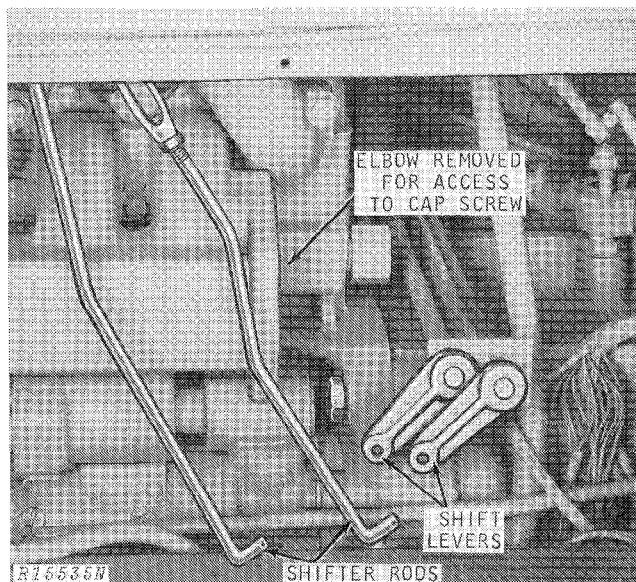

Fig. 8-Shifter Rods and Shifter Levers

Disconnect elbow from air intake manifold and shifter rods from shifter levers (Fig. 8).

Remove selective control valve pressure hose clamp from left-hand front engine support.

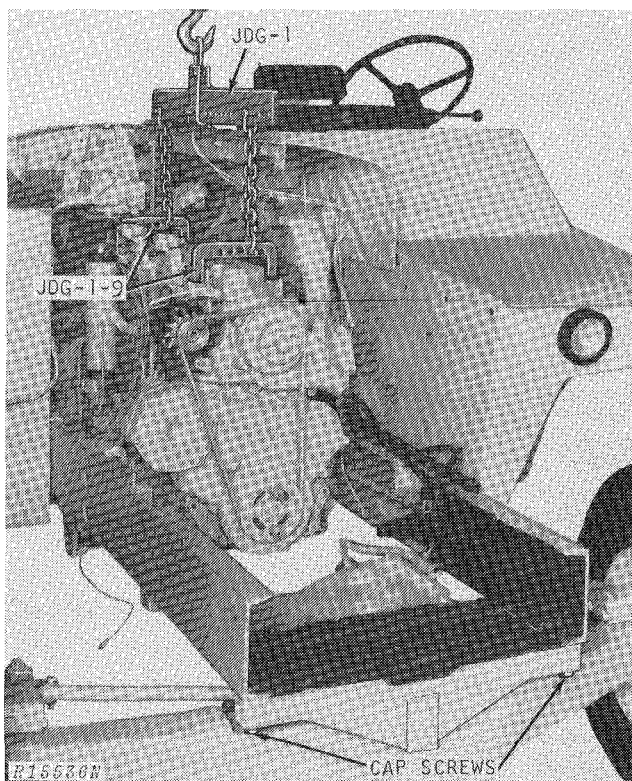

Fig. 9-Engine Lift Brackets and Sling

Disconnect steering cylinders from brackets. Retract left-hand steering cylinder and allow oil pan rock guard to be removed.

Remove engine oil cooler.

Remove bracket between engine and upper hood and dash support.

Install engine lift brackets and sling (Fig. 9). Raise tractor. Move front axle pivot bracket forward to reinstall front pivot bracket to side frame cap screws in front holes of side frame.

Remove cap screws securing engine-to-clutch housing and side frames and remove engine.

Assembly

Install engine to clutch housing and side frames. Tighten cap screws to specified torque.

Raise tractor. Return front axle pivot bracket into position and tighten cap screws to 300 ft-lbs torque.

Remove engine lift brackets and sling.

Install engine oil cooler, oil pan rock guard, and steering cylinders.

Reverse removal procedures 1 through 13 (page 25-4).

Fill the cooling system. Install left-hand engine cover and disconnect clutch pedal.

Install grille housing, lower dust cover, and front bumper.

Connect horn wires, accumulator hoses, and oil cooler hoses.

Connect batteries. Install sheet metal and muffler.

Bleed the fuel system, start the engine and check for leaks.

Install scraper as described on page 10-25-10.

REMOVING AND INSTALLING CLUTCH HOUSING

Remove scraper as shown on page 10-25-10.

Disconnect batteries, discharge brake accumulator, and drain the transmission case.

When using a floor jack to separate the unit between the clutch housing and cylinder block, it will be necessary to completely remove the front drawbar support.

When using an overhead hoist to separate the unit between the clutch housing and cylinder block, leave one cap screw in each side of the front drawbar support and allow support to swing downward.

Remove both rear fenders.

Remove muffler, hood, engine disconnect pedal, and left-hand engine cover.

Remove right-hand engine shield from side frame.

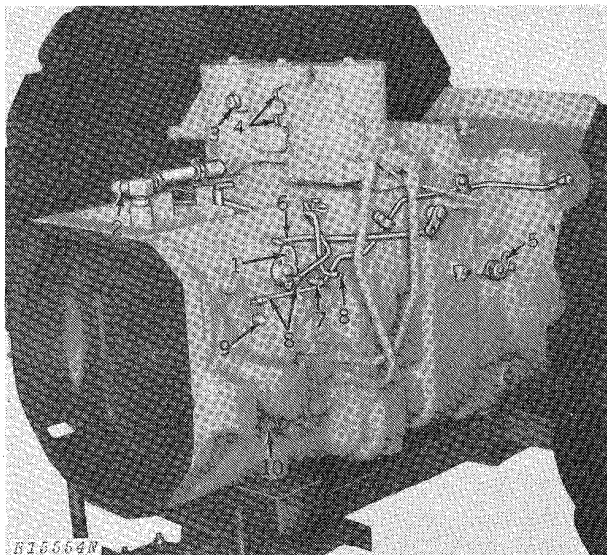

- 1-Clutch Valve
- 2-Hydraulic Return Oil Line
- 3-Selective Control Valve Return Oil Line
- 4-Oil Line Connections
- 5-Park Lock
- 6-PTO Reversing Valve Shifter Rod
- 7-PTO Clutch Arm Connection
- 8-Brake and Differential Lock Lines
- 9-Steering and Brake Return Oil Line
- 10-Inlet Line to Main Pump

Fig. 10-Left Hand Side of Clutch Housing and
Transmission Case
(Early Units Shown)

Disconnect inching pedal rod from clutch valve (1, Fig. 10).

Disconnect shifter rods.

Disconnect ether aid line and remove air intake pipe. Remove air intake elbow from manifold.

Disconnect transmission temperature gauge bulb.

Remove shifter cross shaft assembly.

Disconnect wiring from start-safety switch and oil pressure sender.

Remove selective control valve return oil line (3, Fig. 10).

Disconnect oil lines (4, Fig. 10) between transmission filter and transmission control valve and remove valve.

IMPORTANT: The machined surface on the transmission case where the control valve connects can be easily damaged allowing possible leakage. Protect the surface when removing and installing transmission and clutch housing to engine.

Disconnect park lock cable from park lock (5, Fig. 10). (Make sure park cable is in full reverse.)

Remove PTO clutch return spring.

Disconnect shifter rod (6, Fig. 10) from PTO reversing valve bell crank on disconnect clutch cross shaft assembly. Disconnect engine disconnect clutch shift rod and release button rod. Remove disconnect clutch cross shaft assembly.

Disconnect PTO clutch arm from valve (7, Fig. 10).

Disconnect brake lines and differential lock line from operator's station (8, Fig. 10). Lines may stay attached to rear half of unit but remove lines from clamps.

Remove steering and brake return oil line from clutch housing (9, Fig. 10).

Disconnect pump inlet line between transmission pressure control valve and hydraulic pump (10, Fig. 10). Loosen clamps and pivot line away from clutch housing flange.

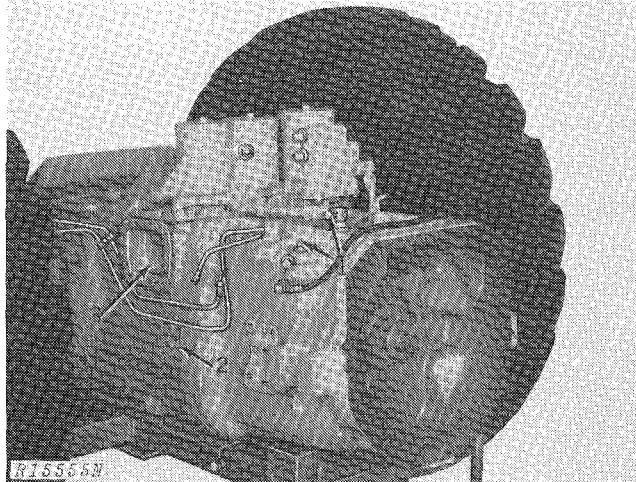

- 1-Pressure Switch and Return Oil Line
- 2-Main Pump Oil Seal Bleed Tube
- 3-Transmission Control Valve Removed

Fig. 11-Right Hand Side of Clutch Housing and Transmission Case (Early Units Shown)

Disconnect wire from transmission lube oil pressure switch and hydraulic return oil line from clutch housing (1, Fig. 11).

Disconnect hydraulic pump oil seal bleed tube (2, Fig. 11) from transmission case.

Remove front drawbar support and rear frame stabilizer.

Use portable hoist to support transmission case. Place suitable blocking (stands) under operator's station, fuel tank, and engine.

Place tow disconnect lever in disengaged position (move lever to rear).

Scribe position of roll pin in tow disconnect lever to transmission case cover. Unhook spring, remove roll pin and lift tow disconnect lever from shaft.

Remove cap screws securing engine to clutch housing and side frames to rear axle housings. Roll rear half of tractor away.

Place blocking at front of transmission case.

Remove transmission top cover.

Remove transmission case-to-planetary lines.

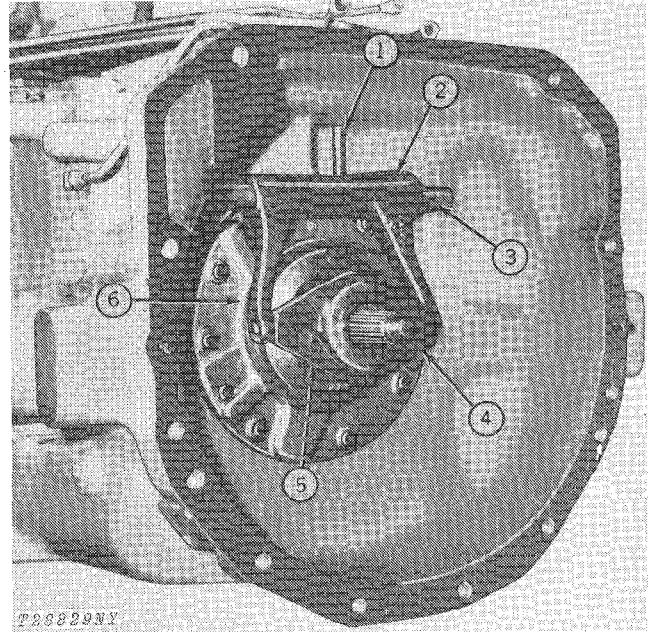

- 1-Clutch Control Rod
- 2-Clutch Fork
- 3-Clutch Fork Shaft
- 4-Clutch Release Bearing Carrier
- 5-Spacer (-30891)
- 6-Transmission Pump and Clutch Pack Assembly

Fig. 12-Engine Clutch Housing Removed

Space blocking under clutch housing so cap screws may be removed from transmission case-to-clutch housing. Remove PTO reverser rod. Remove cap screws and split housing.

During removal of clutch housing from transmission case, make certain that the power shaft idler gear shaft does not slide out of position in housing. Using a light, look between splitting area on left side and check shaft. If shaft is moving out, use a long screw driver to push shaft back into position.

Assembly

Move clutch housing and transmission case back together. As clutch housing to transmission case cap screws are started reach in front side of clutch housing and turn shafts to check for proper mesh with planetary pack. Also check PTO shaft for engagement.



Suggest:

If the above button click is invalid.

Please download this document

first, and then click the above link

to download the complete manual.

Thank you so much for reading

Reverse procedure used for splitting clutch housing from transmission case.

Align scribe mark on tow disconnect lever with scribe mark on transmission case cover. Install roll pin. Check operation of tow disconnect.

Move tractor halves together. Do not use excessive force. Be sure to align splines of transmission drive shaft.

Tighten clutch housing-to-engine cap screws and side frames-to-rear axle housing cap screws to 300 ft-lbs torque.

Remove hoist and blocking.

Reverse separation procedures.

Fill the transmission case and connect batteries.

Start the engine, check for leaks, bleed the brakes, and check transmission shifting.

Install scraper as described on page 10-25-10.

<https://www.ebooklibonline.com>

Hello dear friend!

Thank you very much for reading.

Enter the link into your browser.

The full manual is available for immediate download.

<https://www.ebooklibonline.com>