

**John Deere
JD740
Grapple Skidder**

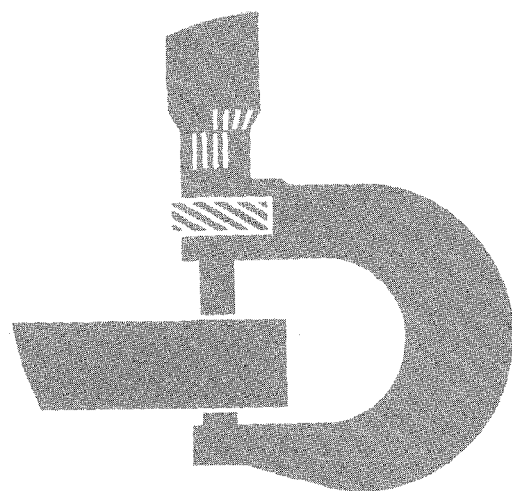

TECHNICAL MANUAL

TM-1101

Litho in U.S.A. (T) New

JD740 GRAPPLE SKIDDER

Technical Manual
TM-1101 (Jan-80)

SECTION AND GROUP CONTENTS OF THIS MANUAL

- Section I - General Information
 - Group I - Contents and Index
 - Group II - Introduction and Safety Information
- Section 10 - GENERAL
 - Group 5 Specifications
 - Group 10 Predelivery, Delivery, and After-Sale Services
 - Group 15 Lubrication
- SECTION 20 - ENGINE
 - Group 5 Engine Removal and Installation
 - Group 10 Basic Engine
 - Group 15 Engine Lubrication System
 - Group 20 Engine Cooling System
 - Group 25 Fuel System
 - Group 30 Speed Control Linkage
 - Group 35 Air Intake System
 - Group 40 Specifications and Special Tools
- Section 30 - ELECTRICAL SYSTEM
 - Group 5 Batteries
 - Group 10 Charging System
 - Group 15 Starting System
 - Group 20 Lighting and Accessory Components
 - Group 25 Specifications and Special Tools
- Section 40 - POWER TRAIN
 - Group 5 Engine Disconnect Clutch
 - Group 10 Drive Shafts
 - Group 15 Power Shift Transmission
 - Group 20 Axle Assemblies
 - Group 25 Differential
 - Group 30 Specifications and Special Tools
- Section 50 - HYDRAULIC SYSTEM
 - Group 5 Hydraulic Pumps
 - Group 10 Rotate Motor
 - Group 15 Steering Valve
 - Group 20 Brake Valve
 - Group 25 Hydraulic Rotary Joint
 - Group 30 Miscellaneous Control Valves
 - Group 35 Filters, Oil Cooler, Accumulators, and Sump
 - Group 40 Cylinders, Lines, and Fittings
 - Group 45 Specifications and Special Tools
- Section 60 - MISCELLANEOUS COMPONENTS
 - Group 4 Separation
 - Group 5 Winch (-218191)
 - Group 6 Main Winch (218192-)
 - Group 10 Boom and Grapple
 - Group 15 Frames
 - Group 16 Fire Suppression System
 - Group 17 Fire Extinguisher
 - Group 20 Blades
 - Group 25 Log Arch
 - Group 30 Specifications and Special Tools
- Section 70 - SYSTEM TESTING
 - Group 5 General Information
 - Group 10 Engine
 - Group 15 Electrical System
 - Group 20 Power Train
 - Group 25 Hydraulic System
 - Group 26 Hydraulic System (Analyzer)
 - Group 30 Miscellaneous Components
 - Group 35 Specifications and Special Tools

The specifications and design information contained in this manual were correct at the time this machine was manufactured. It is John Deere's policy to continually improve and update our machines. Therefore, the specifications and design information are subject to change without notice. Wherever applicable, specifications and design information are in accordance with SAE and ICED standards.

Copyright © 1974
DEERE & COMPANY
Moline, Illinois
All rights reserved

A-00

Group II INTRODUCTION AND SAFETY INFORMATION

INTRODUCTION

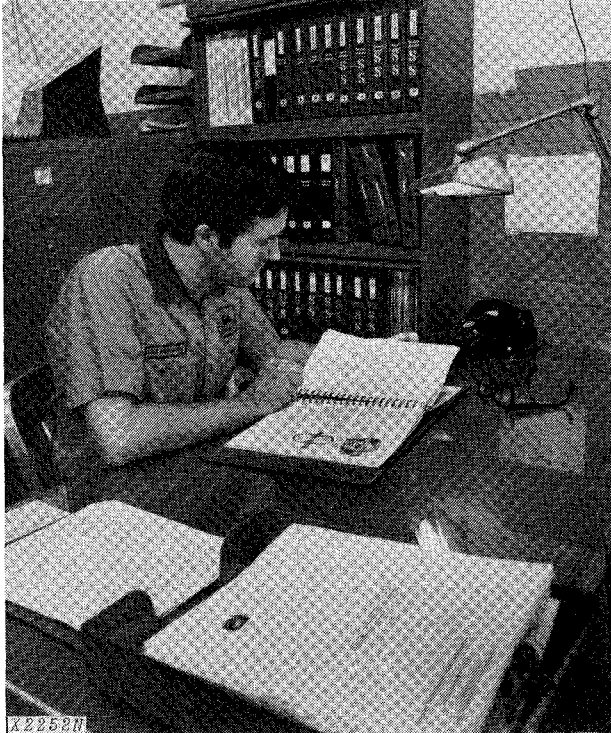

Use FOS Manuals for Reference

This technical manual is part of a twin concept of service:

The two kinds of manuals work as a team to give you both the general background and technical details of shop service.

•FOS Manuals—for reference

Fundamentals of Service (FOS) Manuals cover basic theory of operation, *fundamentals* of trouble shooting, *general* maintenance, and *basic* types of failure and their causes. FOS Manuals are for training new personnel and for reference by experienced service technicians.



When a service technician should refer to a FOS Manual for more information, a FOS symbol like the one at the left is used in the TM to identify the reference.

•Technical Manuals—for actual service

Technical Manuals are concise service guides for a specific machine. Technical manuals are on-the-job guides containing only the vital information needed by an experienced mechanic.

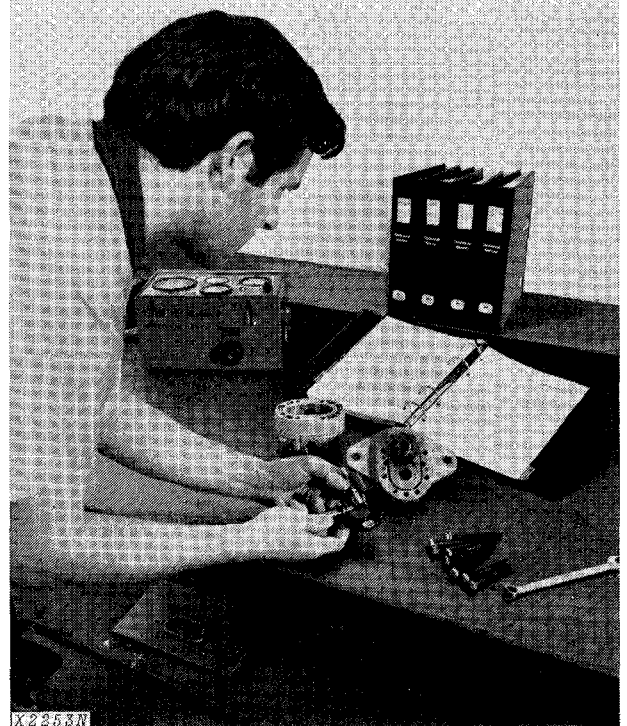

Use Technical Manuals for Actual Service

This technical manual was planned and written for you—an experienced service technician. Keep it in a permanent binder in the shop where it is handy. Refer to it whenever in doubt about correct service procedures or specifications.

Some features of this manual:

- Inside front cover - "Table of Contents" and "Maintenance Without Accident".
- Section 10 - General specifications and services.
- Sections 20 through 60 - Removal, repair, testing (components removed), installation, and adjustment.
- Section 70 - Detailed explanation of system operation, diagnosis, visual inspection, testing, and adjustments.
- Specifications grouped and illustrated at the end of each section.

<https://www.ebooklibonline.com>

Hello dear friend!

Thank you very much for reading.

Enter the link into your browser.

The full manual is available for immediate download.

<https://www.ebooklibonline.com>

MAINTENANCE WITHOUT ACCIDENT WORK SAFELY



T27999

 This safety alert symbol identifies important safety messages in this manual and on the grapple skidder. When you see this symbol, be alert to the possibility of personal injury and carefully read the message that follows.

EVERY EMPLOYER HAS A SAFETY PROGRAM. KNOW WHAT IT IS!

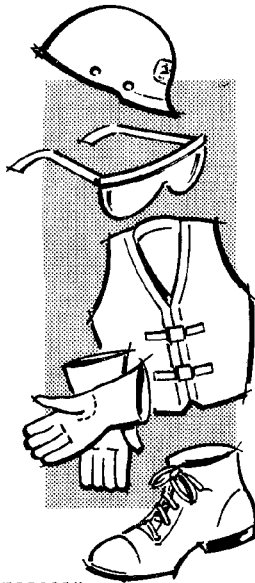

T27501N

Consult your shop supervisor for specific instructions on a job, and the safety equipment required.

For instance, you may need: Hard hat, safety shoes, safety goggles, heavy gloves, reflector vests, ear protectors, respirators.



T27502N

ALWAYS AVOID loose clothing or any accessory—flopping cuffs, dangling neckties and scarves, or rings and wrist watches—that can catch in moving parts and put you out of work.

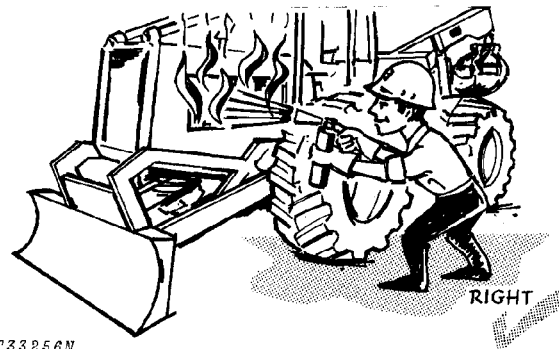

T33256N

BE ALERT!

Plan ahead—work safely—avoid accidental damage and injury. If a careless moment does cause an accident or fire, react quickly with the tools and skills at hand—know how to use a first-aid kit and a fire extinguisher—and where to get aid and assistance. In an emergency, split-second action is the key to safety.

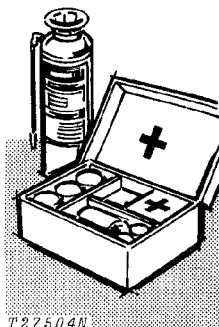

T27504N

MAINTENANCE WITHOUT ACCIDENT

Specific safety procedures should always be observed, whether servicing or making repairs on the grapple skidder. Remember these—in time!—can prevent an injury . . . or save your life

AVOID FIRE HAZARDS—

Fuel Is Dangerous!

Don't smoke while refueling.
Don't smoke while handling highly flammable material.

Engine should be shut off when refueling.
Use care in refueling if the engine is hot.

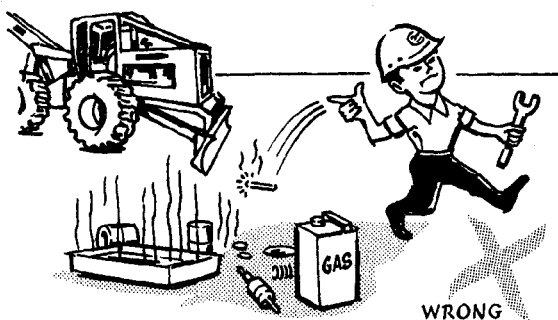

T33257N

Don't use open pans of gasoline or diesel fuel for cleaning parts. Good commercial, nonflammable solvents are preferred.

Battery Gas Is Highly Flammable!

Provide adequate ventilation when charging batteries.



T27506N

Don't check battery charge by placing metal objects across the posts.
Don't allow sparks or open flame near batteries.
Don't smoke near battery.

Flame Is Not a Flashlight!

Never check fuel, battery electrolyte or coolant levels with an open flame.

Never use an open flame to look for leaks anywhere on the equipment.

Never use an open flame as a light anywhere on or around the equipment.

KNOW WHERE FIRE EXTINGUISHERS ARE KEPT!

UNDER ALL MAINTENANCE CONDITIONS—

Do not perform any work on the grapple skidder unless authorized to do so. Then be sure you understand the services required. Follow recommended procedures.

Never service the equipment while it is being operated.

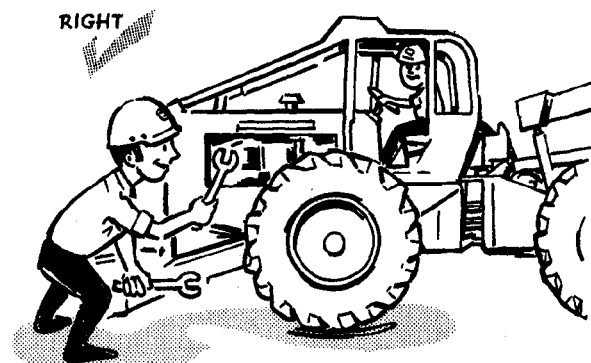

T33258N

Avoid working on equipment with the engine running. If it is necessary to make checks with the engine running, **ALWAYS USE TWO SERVICE TECHNICIANS**— one, the operator, at the controls, the other checking in view of the operator. Also, put the transmission in neutral, set the brake, and apply any safety locks provided. **KEEP HANDS AWAY FROM MOVING PARTS.**

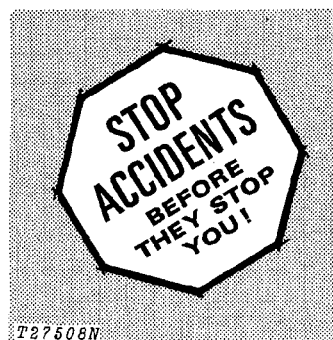

T27506N

MAINTENANCE WITHOUT ACCIDENT

Before servicing, adjusting, or repairing grapple skidders which have attachments such as blades, grapple tongs, etc.—**LOWER** attachments to the ground—or, if necessary to raise them for access to certain parts, **SECURELY SUPPORT** by external means. **DO NOT** rely on controls to support or position attachments for maintenance.

Never allow **ANYONE** to walk under equipment that is raised and not properly blocked.

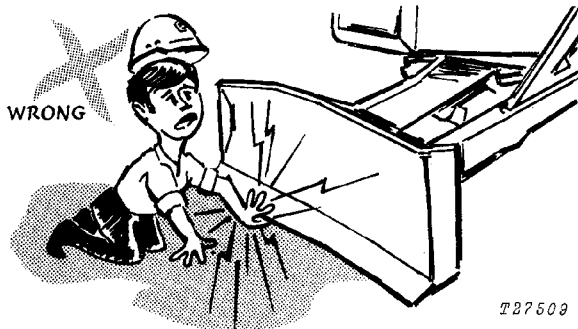

Avoid working directly under raised and blocked equipment unless absolutely necessary.

If the grapple skidder is on an incline, block it securely.

Use hoisting equipment for lifting heavy parts. **TAKE CARE! WATCH OUT FOR OTHER PEOPLE IN THE VICINITY.**

Use extreme caution in removing radiator caps, drain plugs, grease fittings, or hydraulic pressure caps.

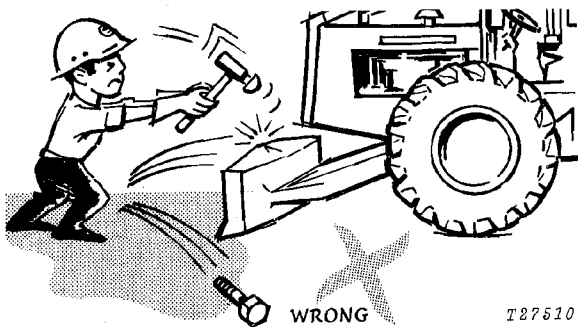

Wear safety glasses when drilling, grinding, or hammering metal.

Make sure the maintenance area is adequately vented.

Keep maintenance area **CLEAN AND DRY**. Oily and wet floors are slippery; greasy rags are a fire hazard; wet spots are dangerous when working with electrical equipment.

Store starting aids in a cool and well-ventilated place, out of the reach of unauthorized personnel.

SERVICING PRECAUTIONS

Stop the engine before cleaning or lubricating the grapple skidder.

Lower blade and grapple to the ground *carefully*.

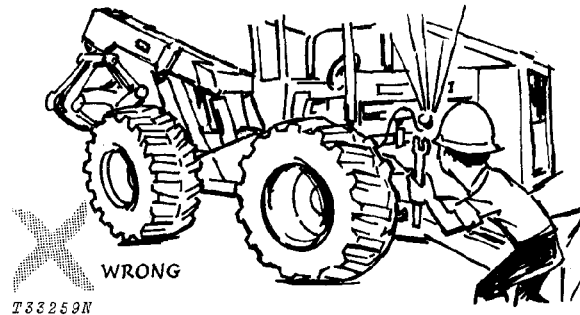

Engine coolant gets hot! Don't remove the radiator cap until coolant temperature is below the boiling point. Then turn cap slightly to relieve pressure before removing.

Exhaust gases are dangerous! Periodically check exhaust system for excessive leakage.

Don't forget a hydraulic system may be pressurized! To relieve system pressure, stop engine, lower blade and boom and operate blade, boom or grapple controls until system fails to respond.

When checking hydraulic pressure, be sure to use the correct test gauge for the pressure in the particular system.

The grapple skidder is equipped with a brake accumulator—recharge by using only dry nitrogen. To discharge brake accumulator apply the brake pedal about 30 times.

MAINTENANCE WITHOUT ACCIDENT

When preparing engine for storage, remember that inhibitor is volatile and therefore dangerous. Seal and tape openings after adding inhibitor. Keep container tightly closed when not in use.

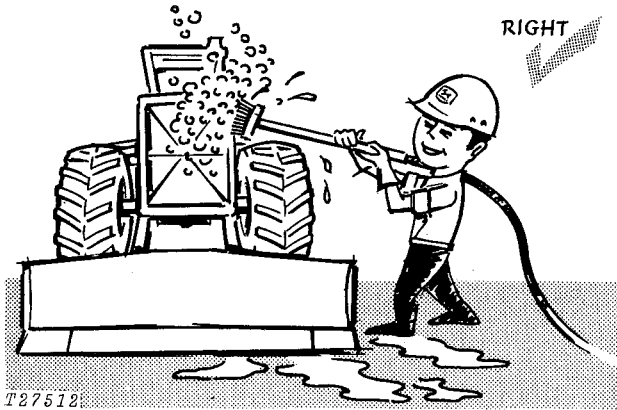

Keep ALL components free of dirt and oil. This attention will minimize fire hazards and facilitate spotting of loose or defective parts.

ADJUSTING PRECAUTIONS

...for Operating Adjustments

Keep clutch and brake control units properly adjusted at all times. Before making adjustments, stop engine.

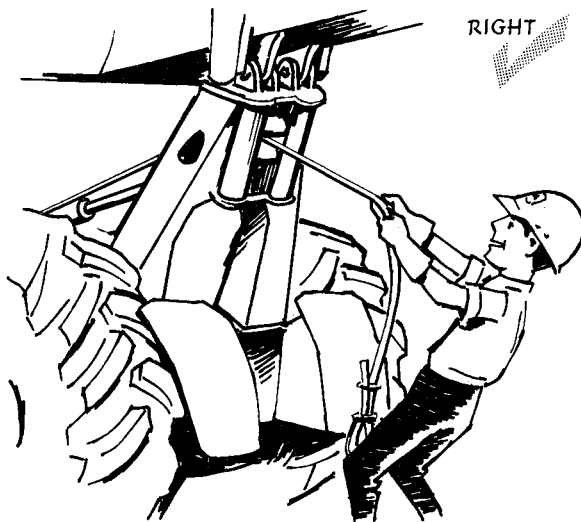

Always wear gloves when handling cable.

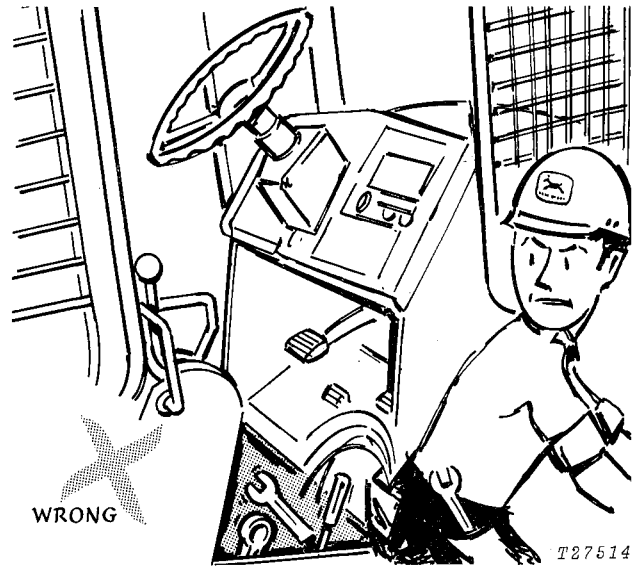

Before removing any housing covers, stop engine. Take all objects from your pockets which could fall into the opened housings. Don't let adjusting wrenches fall into opened housings.

...for Maintenance Adjustments

Don't attempt to check belt tension while the engine is running.

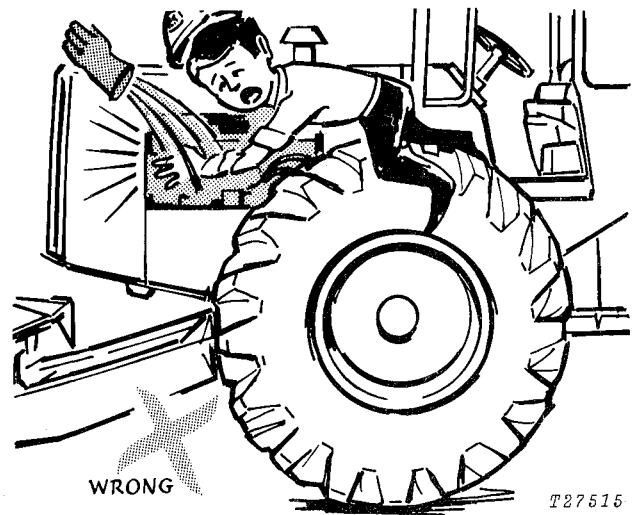

Don't adjust the fuel system while the machine is in motion.

MAINTENANCE WITHOUT ACCIDENT

PRECAUTIONS DURING REPAIR

Before working on the engine fuel system—close fuel shutoff valve.

Before working on hydraulic system—make sure engine is not running and the system pressure is relieved by working the control levers in all directions with the engine shut off.

Before repairing the electrical system, or performing a major overhaul, make sure the batteries are disconnected.

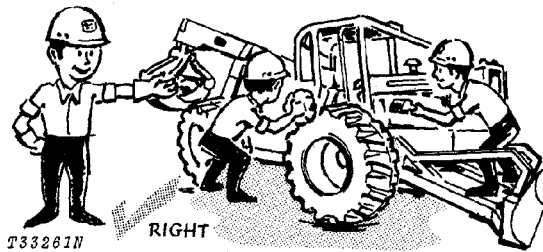

Keep all equipment free of dirt and oil. This attention will minimize fire hazards and facilitate spotting of loose or defective parts.

When changing cutting edges on blade—

Stop the engine and securely block the blade.

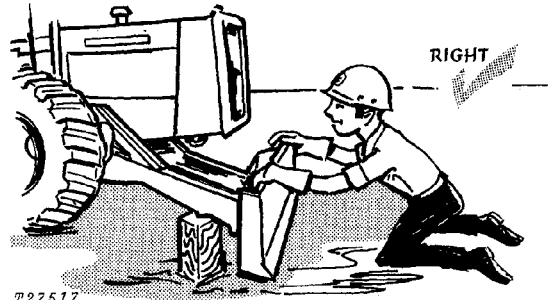

Never let your bare hands come in contact with sharp edges. WEAR GLOVES.

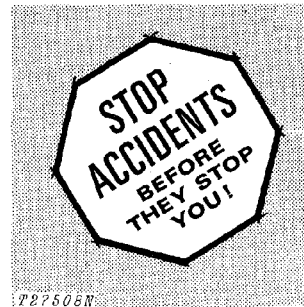

MAINTENANCE WITHOUT ACCIDENT

KNOW EQUIPMENT IS READY!

Check guards, canopies, safety bars—all protective devices installed on the grapple skidder. Every one should be in place and secure.

CHECK IT OUT!

- GUARDS
- CANOPIES
- SHIELDS
- PROTECTIVE DEVICES
- ROLL-OVER PROTECTIVE STRUCTURES
- SEAT BELTS
- FIRE EXTINGUISHER
- FIRE SUPPRESSION SYSTEM, ETC.

RIGHT

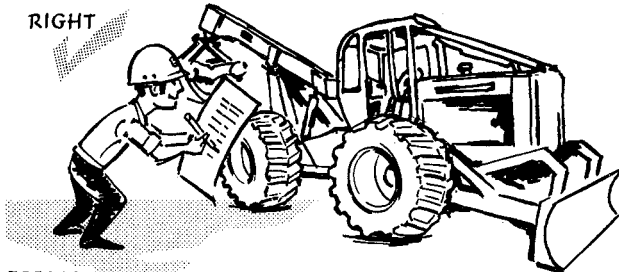

T33262N

Carefully inspect equipment for visual defects—leaks in fuel, lubrication, and hydraulic systems. Do not search for pressurized fluid leaks with your hands. Use cardboard or wood to search for leaks.

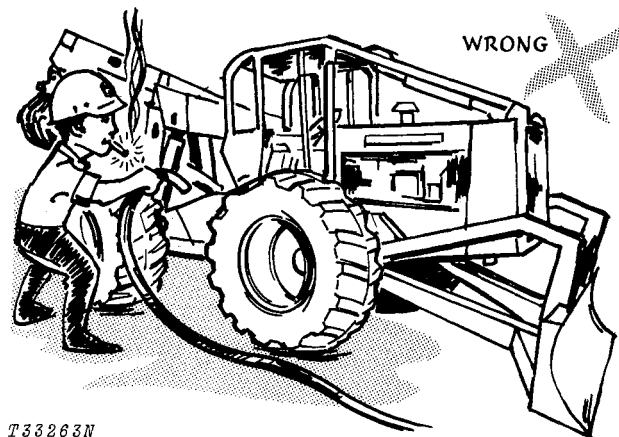

T33263N

Check levels of fuel, coolant, hydraulic fluid, and lubricating oil. If fuel must be added—**FIRST, PUT OUT THAT CIGARET.**

Check and secure all caps and filler plugs for fuel, oils, radiator, etc.

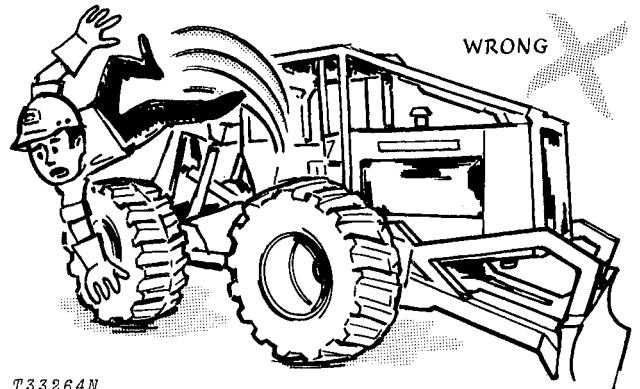

T33264N

Be sure to clean any oil, grease or mud accumulation from floor of operator's compartment, stepping points, and grab rails to minimize the danger of slipping.

In freezing weather beware of snow or ice deposits on stepping points, grab rails, and floor.

Remove loose bolts, tools, or other objects from floor of operator's compartment.

Although it is impractical to try to cover every possible maintenance situation, the safety precautions recommended here should serve to develop and promote safe maintenance procedures.

The information contained in this manual is not intended to replace safety codes, insurance requirements, federal, state, and local laws, rules and regulations. In particular, your service area or jobsite activities may be subject to state safety rules and/or federal regulation under the Occupational Safety and Health Act (OSHA). Familiarize yourself with all regulations applicable to your situation in order to avoid possible safety violations.

Illustrations and copy reproduced in part by permission of Construction Industry Manufacturers' Association (CIMA).

Section 10 GENERAL

CONTENTS OF THIS SECTION

| | Page | | Page |
|--|-------|--|------|
| GROUP 5 - SPECIFICATIONS | | GROUP 15 - LUBRICATION | |
| General Machine Specifications | 5-2 | General Information | 15-1 |
| GROUP 10 - PREDELIVERY, DELIVERY, AND AFTER-SALE SERVICES | | Grapple Skidder Periodic Service Chart | 15-1 |
| Temporary Machine Storage | 10-1 | Engine Lubricating Oil | 15-2 |
| Predelivery Service | 10-2 | Transmission-Hydraulic Oils | 15-2 |
| Delivery Service | 10-18 | Greases | 15-2 |
| After-Sale Inspection | 10-18 | | |

Group 5

GENERAL MACHINE SPECIFICATIONS

POWER (at 2,200 engine rpm):

| | SAE | Din |
|-------------|--------------------|------------|
| Gross | 160 hp (119.3 kW*) | |
| Net | 145 hp (108.1 kW) | 147 PS |

Net engine flywheel power is for an engine equipped with fan, air cleaner, water pump, lubricating oil pump, fuel pump, alternator, and muffler. The gross engine power is without fan. Flywheel power ratings are under SAE standard conditions of 500-ft. (150 m) altitude and 85°F (29°C) temperature and DIN 70 020 (non-corrected). No derating is required up to 10,000 feet (3 000 m) altitude.

**In the International System of Units (SI), power is expressed in kilowatts (kW).*

ENGINE:

John Deere diesel, vertical 6-cylinder, valve-in-head 4-stroke cycle—turbocharged and intercooled.
 Bore and stroke 4.25x4.75 in. (108x121 mm)
 Piston displacement 404 cu. in. (6 622 cm³)
 Compression ratio 15.5 to 1
 Maximum torque @ 1,400 rpm 457 lb-ft (63.2 kg/m)
 N.A.C.C. or A.M.A. (U.S. Tax) horsepower 43.3
 Lubrication Pressure system with full-flow filter
 Cooling Pressurized with thermostat and fixed bypass
 Fan Blower
 Air cleaner with restriction indicator Dry
 Starting system 12-volt with alternator
 Batteries, two reserve capacity: 180 minutes each

DIFFERENTIALS:

Front and rear Full differentials with hydraulic lock

ENGINE CLUTCH DISCONNECT:

Hand-operated, spring-loaded, dry-disk. Single plate, 12 in. (305 mm)

TRANSMISSION:

Power Shift with planetary gears, hydraulically actuated wet-disk clutches and brakes; provides 8 speeds forward—4 reverse. Controlled by single lever. Pressurized lubrication.

TRAVEL SPEEDS (2,200 engine rpm, no tire slip):

Forward: 1.78 mph (2.9 km/h) to 19.38 mph (31.2 km/h)
 Reverse: 2.29 (3.7 km/h) to 6.65 mph (10.7 km/h)

DRIVE AXLES:

Four-wheel drive with inboard planetary gears on all axles. Front axle oscillates 15 degrees above and below horizontal. 24.9 in. (632 mm) total travel at tire center line at narrowest tread.

BRAKES:

Hydraulic power actuated, pedal-controlled wet disk-type on 4 wheels.
 Winching Manually locked service brakes.
 Parking Foot-operated mechanical disk.

POWER STEERING:

Articulated frame hydraulically actuated by dual cylinders.
 Turning radius 18 ft. 10.7 in. (5.76 m)
 Turning clearance circle 40 ft. 5.5 in. (12.33 m)
 Number of turns, far left to far right 3

HYDRAULIC SYSTEM:

Closed-center, constant pressure. Variable-displacement pump driven from crankshaft 54 gpm (205 L/min), 2,000 psi (141 kg/cm²) @ 2,200 engine rpm. Oil cooler included in system.

TIRES:

24.5-32, 16-ply-rating, steel-ply, LS-2
 30.5-32, 16-ply-rating, logging, LS-2
 *24.5-32, 16-ply-rating, kevlar-ply, LS-2
 *30.5-32, 16-ply-rating, kevlar-ply, LS-2
 *Canada only

CAPACITIES:

| | U.S. | Litre |
|--|-------------|--------------|
| Fuel tank | 54 gal. | 204.7 |
| Cooling system | 12 gal. | 45.4 |
| Engine lubrication, including filter | 20 qt. | 18.9 |
| Transmission-hydraulic system | 42 gal. | 159.0 |
| Front differential | 26 qt. | 24.6 |
| Rear differential | 26 qt. | 24.6 |

SAE OPERATING WEIGHT 34,150 lb. (15 490 kg)

WINCH:

Live mechanical drive; hydraulically actuated clutch and brake. Single lever control.

Cable capacities*:

| | |
|-----------------------------|--------------------|
| 1/2-in. (12.7 mm) | 577 ft. (175.87 m) |
| 5/8-in. (15.8 mm) | 379 ft. (115.52 m) |
| 3/4-in. (19 mm) cable | 267 ft. (81.4 m) |
| 7/8-in. (22.2 mm) | 192 ft. (58.52 m) |
| 1-in. (22 mm) cable | 149 ft. (45.4 m) |

**Calculated: No allowance made for loose or uneven spooling.*

Line pull (2,200 rpm):

| | |
|-----------------|------------------------|
| Bare drum | 49,397 lb. (22 406 kg) |
| Full drum | 28,227 lb. (12 804 kg) |

Line speed (2,200 rpm):

| | |
|-----------------|----------------------|
| Bare drum | 116 fpm (35.5 m/min) |
| Full drum | 204 fpm (62.0 m/min) |

ARCH (integral in grapple frame):

| | |
|---|-------------------------|
| Horizontal roller | 6 in. (152.4 mm) dia. |
| Vertical rollers (through-hardened steel) | 4.5 in. (114.3 mm) dia. |

Hydraulic Cylinders:

| | Bore | Stroke |
|-----------------------------------|---|-----------------------|
| Boom and arch (2 ea.) | 4.25 in. (108 mm) | 29.81 in. (757.17 mm) |
| Grapple (1) | 6.25 in. (158.75 mm) | 19.75 in. (502 mm) |
| Cylinder rods | Ground, heat-treated, chrome-plated polished. | |
| Boom and arch cylinder rods | 2 in. dia. | (50.8 mm) |
| Grapple cylinder rod | 2.75 in. dia. | (69.85 mm) |

ADDITIONAL STANDARD EQUIPMENT:

| | |
|--|--|
| Exhaust with rain deflector | Deluxe seat with suspension |
| Fuel level dipstick | Foot throttle |
| Electric hour meter | Hand throttle |
| Key switch with push-button safety start | Hinge lock bar |
| Fire extinguishers (2) | Roll-over protective structure (ROPS) with canopy and seat belt, and brush screens |
| Bottom guards | Lights |
| Cold weather starting aid | Muffler |
| Vandal protection | Parking brake |
| Horn | Transistorized voltage regulator |
| Cigar lighter | |
| Engine side shields | |

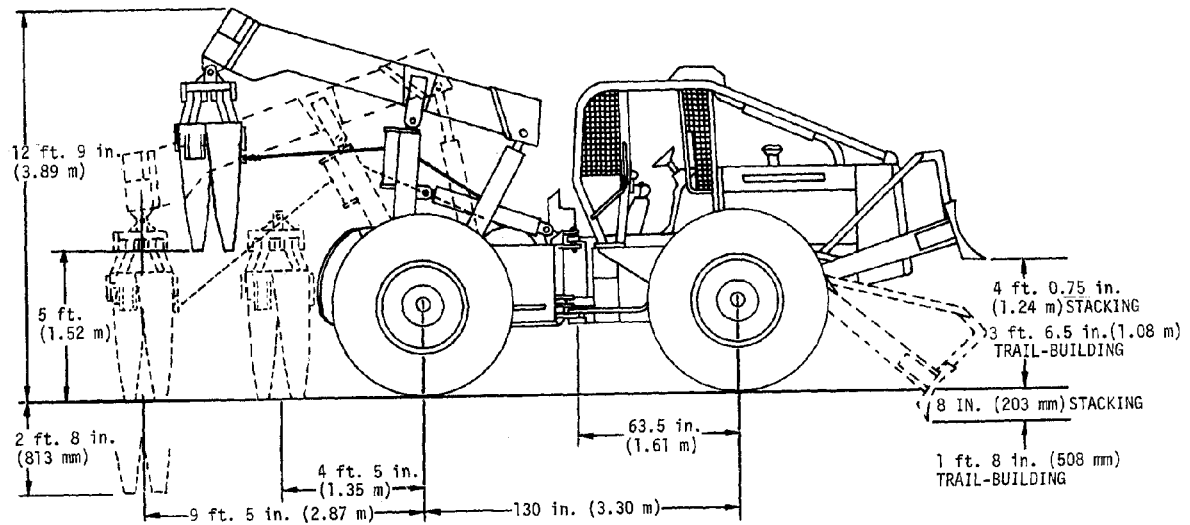

T54208

Sideview dimensions are for Grapple Skidder equipped with 24.5-32 tires, grapple open.

DIMENSIONS:

| Tire Size | A Wheel Tread | B Ground Clearance | C Over-All Width |
|-----------|---------------------|--------------------------|----------------------------|
| 24.5-32 | 93 in. (2.36 m) | 21.6 in. (549 mm) | 9 ft. 9.5 in. (2.98 m) |
| 30.5-32 | 97 in. (2.46 m) | 20 in. (508 mm) | 10 ft. 7.5 in. (3.24 m) |

BLADE DIMENSIONS:

| D Width Trail Building | E Width Stacking | F Height Trail Building | G Height Stacking |
|------------------------------|-------------------------|-------------------------------|---------------------------|
| 9 ft. 4 in. (2.84 m) | 7 ft. 2 in. (2.18 m) | 2 ft. 8 in. (813 mm) | 1 ft. 8.5 in. (521 mm) |

DIMENSIONS NOT SHOWN:

- Distance between extended grapple tongs 10 ft. (3.05 m)
- Diameter of smallest log 6 in. (152 mm)
- Tip closure force 7000 lbs. (3175 kg)
- Enclosure area, tips meeting 15 sq. ft. (1.39 m²)

SPECIAL EQUIPMENT:

- Stacking blade
- Wheel weights
- Trail blade vertical extension
- Depth gauge shoe assembly
- Pressurized cab with heater
- Automatic fire suppression system
- Engine coolant heater

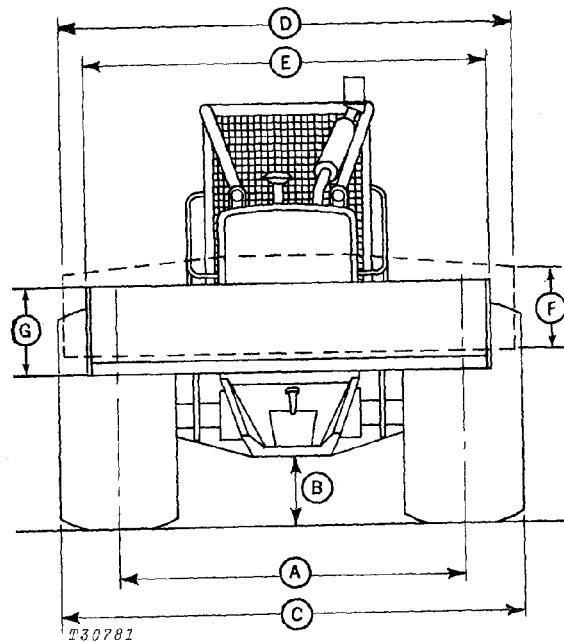

(Specifications and design are subject to change without notice. Wherever applicable, specifications are in accordance with ICED and SAE Standards. Except where otherwise noted, these specifications are based on a unit equipped with 30.5-32, 16-ply-rating logging tires and standard equipment.)

Litho in U.S.A.

Group 10

PREDELIVERY, DELIVERY AND AFTER-SALE SERVICES

TEMPORARY STORAGE

After receiving your grapple skidder from the factory and before putting the grapple skidder into temporary storage, perform the following checks.

1. Check battery electrolyte level and charge the battery, if necessary.
2. Check coolant level in the radiator. Maintain coolant at a level midway between radiator core and filler neck.
3. Check crankcase oil level. Oil should be at top mark on dipstick after machine has been shut down for 10 minutes.
4. Relieve hydraulic pressure by lowering blade, stopping engine, and operating blade control levers until system fails to respond.

PREDELIVERY SERVICE

Because of the shipping factors involved, plus extra finishing touches that are necessary to promote customer satisfaction, proper predelivery service is of prime importance to the dealer and the customer.

If adjustments are required, procedures are found in the After-Sale section.

Use the following list when preparing a grapple skidder for delivery to the customer.

1. Air Cleaner

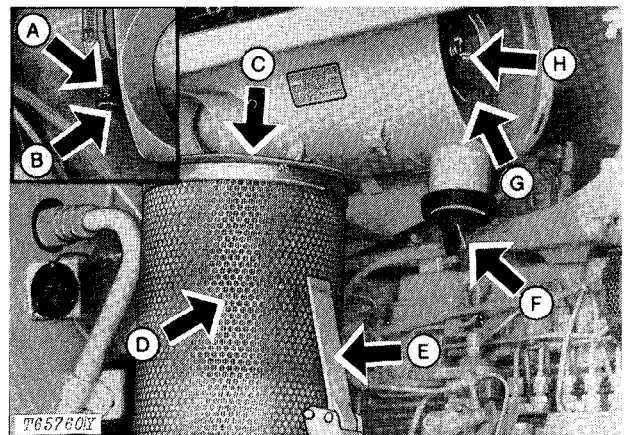

- | | |
|--------------------------------|-------------------------|
| A—Restriction Indicator | E—Lever |
| B—Reset Button | F—Unloader Valve |
| C—Air Cleaner Cover | G—Safety Element |
| D—Primary Element | H—Wing Nut |

Fig. 1-Air Cleaner Components

Check air cleaner restriction indicator. If the restriction indicator locks in full view, look for restriction or blockage in air intake system.

| | | |
|-------------------------------------|-----|----|
| <i>Air cleaner elements checked</i> | Yes | No |
| <i>Restriction in system</i> | Yes | No |

2. Radiator

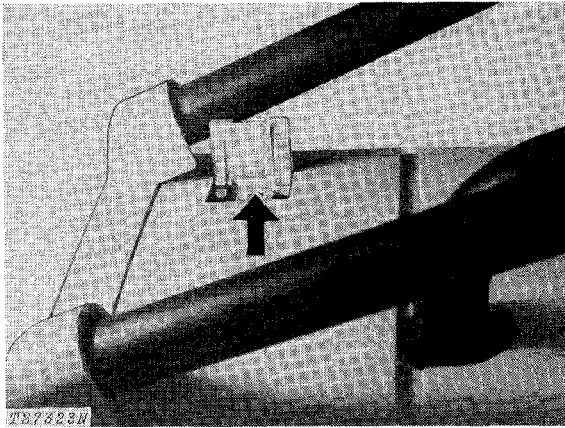

Fig. 2-Radiator Filler Cap

CAUTION: Do not remove radiator filler cap until coolant temperature is below its boiling point. Then loosen cap slowly to the stop to relieve any excess pressure before removing cap completely.

Check coolant level in radiator. Maintain coolant at a level midway between radiator core and filler neck.

The antifreeze-water ratio is approximately 50 per cent each. This protects to at least -34°F (-37°C).

Radiator coolant level checked Yes No

3. Batteries

Remove foreign material from top of batteries. Check battery electrolyte level. If distilled water is not available, use clean soft water. Coat terminals with petroleum jelly.

IMPORTANT: Never add water to battery in freezing weather unless engine is to be run 2 or 3 hours to assure mixing of water and electrolyte.

Check battery connections.

Punch date code on battery.

Water added Yes No
 Battery connections checked Yes No

4. Tire Pressure

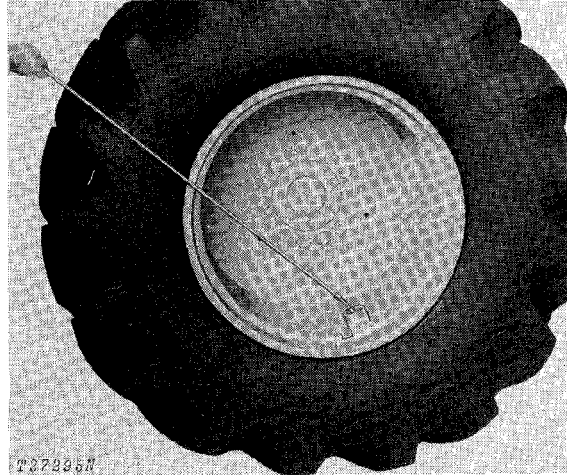

Fig. 3-Correct Tire Testing Procedure

Check the air pressure in the tires with an accurate gauge having 1-psi (0.07 kg/cm²) graduations.

| Tire Size | Type | Ply Rating | Pressure |
|---------------------------|------|------------|----------------------------------|
| *24.5 - 32 | LS-2 | 16 | 25 psi (1.7 kg/cm ²) |
| *30.5 - 32 | LS-2 | 16 | 25 psi (1.7 kg/cm ²) |
| 24.5 - 32 | LS-2 | 16 | 25 psi (1.7 kg/cm ²) |
| 30.5 - 32 | LS-2 | 16 | 25 psi (1.7 kg/cm ²) |
| *Canada only (kevlar-ply) | | | |

CAUTION: Failure to follow proper procedures when mounting a tire on a wheel or rim can produce an explosion which may result in serious bodily injury. DO NOT attempt to mount a tire unless you have the proper equipment and experience to perform the job safely.

Detailed tire mounting instructions, including necessary safety precautions, are contained in John Deere Fundamentals of Service (FOS) Manual 55, Tires and Tracks.

Tire pressure checked Yes No

5. Engine Crankcase Oil Level

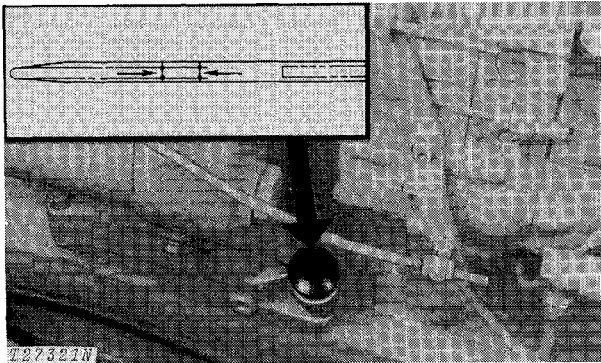

Fig. 4-Dipstick and Oil Filler Cap

Check crankcase oil level with machine on level ground. (Allow a minimum of 10 minutes for the oil to drain down before checking.) If oil level is at or below bottom mark on dipstick, add oil specified on page 10-15-2 to bring oil level to between marks on dipstick. Do not operate engine with oil level below the bottom mark.

Crankcase oil level checked Yes No

Oil added, if any _____qts (L)

6. Transmission-Hydraulic System Oil Level

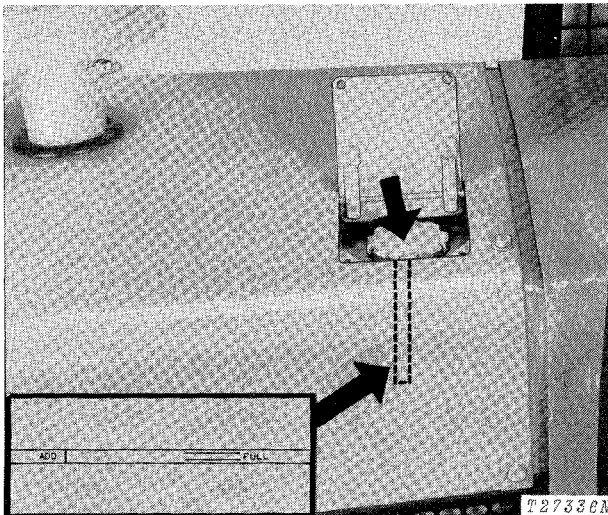

Fig. 5-Dipstick and Oil Filler Cap

Check transmission-hydraulic system oil level as follows:

- A - Start engine.
- B - Engage transmission disconnect clutch if disengaged.
- C - Observe transmission lube pressure gauge. Shut off engine immediately if there is no lube pressure after 30 seconds.
- D - Check oil level in reservoir after 5 minutes.
- E - Oil level should be to top mark on dipstick while resting on filler tube. If low, add oil as specified on page 10-15-2.

Oil level checked Yes No

Oil added, if any _____qts (L)

7. Grease Fittings

The grapple skidder was checked and lubricated before it left the factory. However, to insure customer satisfaction, check each lubrication point shown in the following pages. Lubricate with several strokes of John Deere Multi-Purpose Grease or equivalent if necessary.

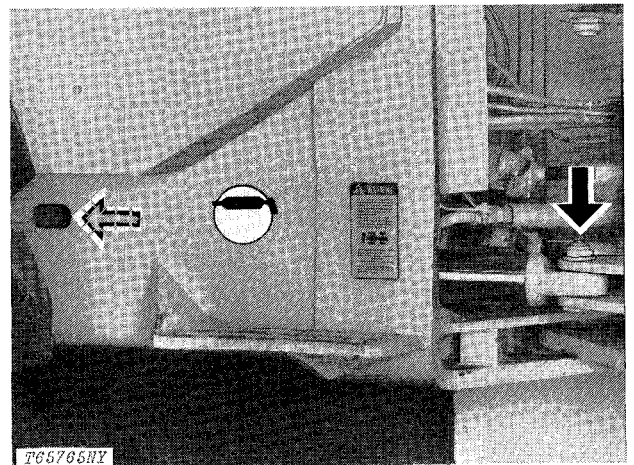
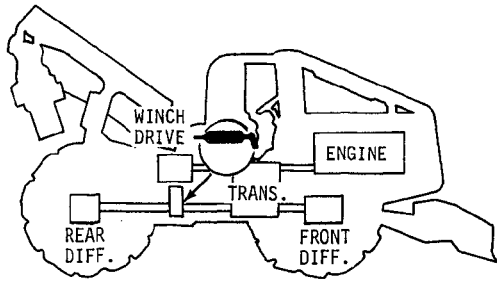

Fig. 6-Steering Cylinder Pivot Pins (4 Points)

Lubricant required Yes No



T53307N

Fig. 11-Lower Drive Shaft Support Bearing (1 Point)

Lubricant required Yes No

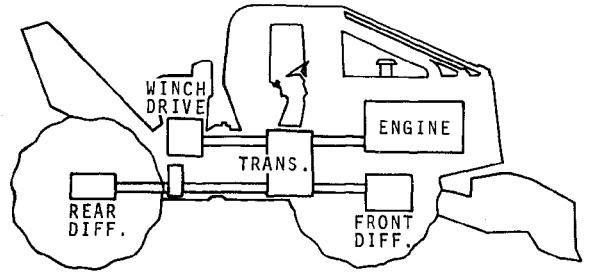

T65214N

A—Axle Universal Joints (3 Points) B—Front Axle Pivots (2 Points)

Fig. 14-Axle Universal Joints and Front Axle Pivots (5 Points)

Lubricant required Yes No

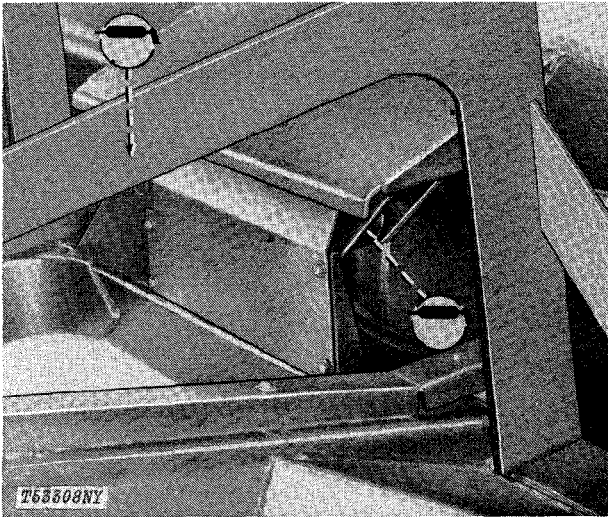

Fig. 12-Trail Building Tilt Cylinder (2 Points)

Lubricant required Yes No

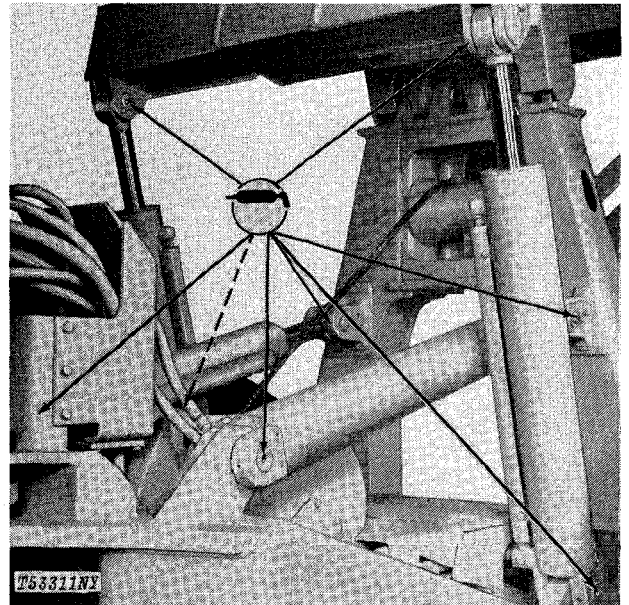
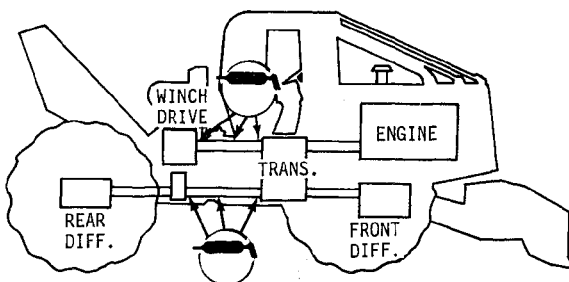

Fig. 15-Cylinder Pins (8 Points)

Lubricant required Yes No



T53309N

Fig. 13-Winch Drive Line and Lower Telescoping Universal Joints (6 Points)

Lubricant required Yes No

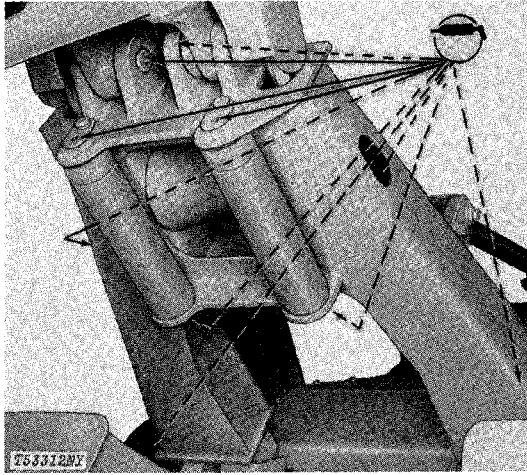

Fig. 16-Arch and Fairlead Pivot Pins (10 Points)

Lubricant required Yes No

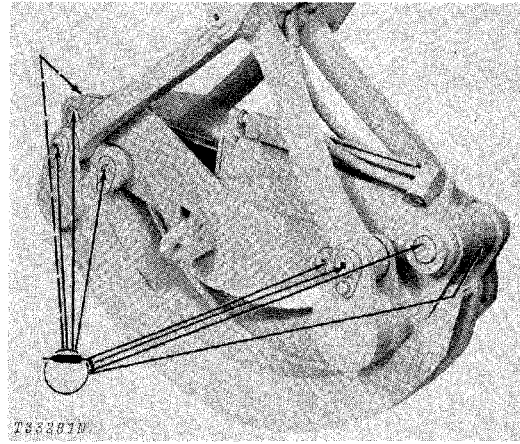

Fig. 18-Grapple Pins (8 Points)

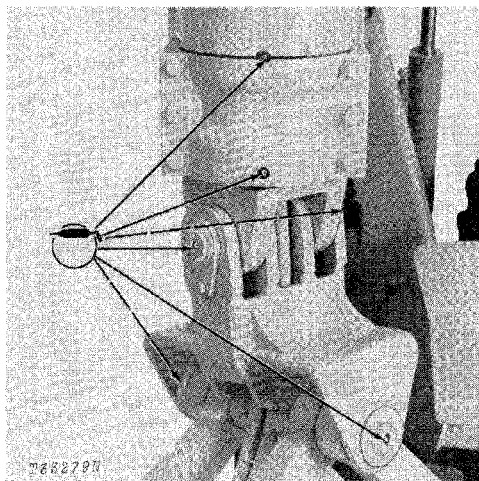

Fig. 17-Rotary Joint Bearing and Yoke Pin (6 Points)

Lubricant required Yes No

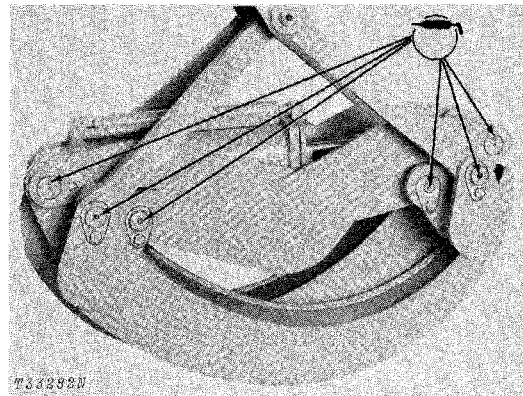

Fig. 19-Grapple Pins (6 Points)

Lubricant required Yes No

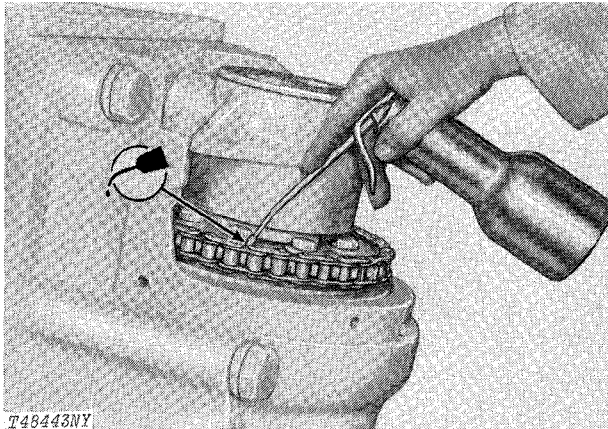

Fig. 20-Rotate Chain (1 Point)

Remove six cap screws and remove rotate chain cover. Check chain for wear or damage. Chain tension should be 1/4 in. to 3/8 in. (6.35 to 9.53 mm) slack with slight finger pressure.

To adjust tension, remove four cap screws holding boom cover and remove boom cover. Loosen 4 cap screws holding mounting bracket to bracket. Turn 2 adjusting cap screws on end of mounting bracket to adjust tension. Tighten 4 cap screws holding mounting bracket.

Lubricate with engine oil.

| | | |
|--------------------|-----|----|
| Lubricant required | Yes | No |
| Chain tightened | Yes | No |

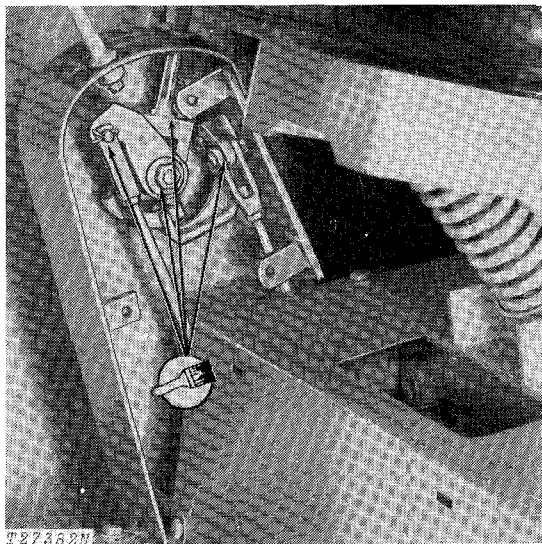

Fig. 21-Shift Control Bell Crank (4 Points)

Lubricate with engine oil.

| | | |
|--------------------|-----|----|
| Lubricant required | Yes | No |
|--------------------|-----|----|

Litho in U.S.A.

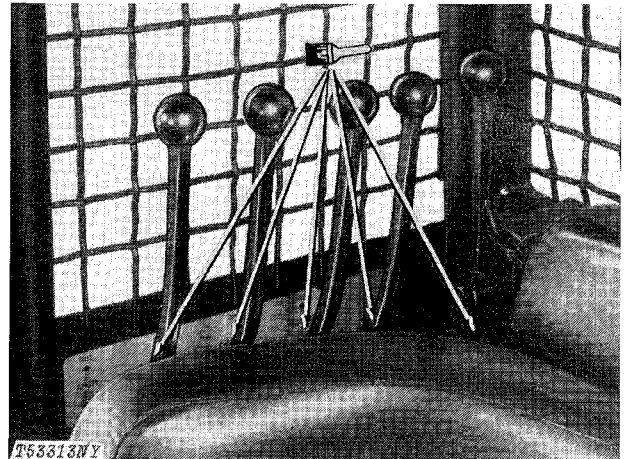

Fig. 22-Winch and Grapple Control Levers (5 Points)

Lubricate with engine oil.

| | | |
|--------------------|-----|----|
| Lubricant required | Yes | No |
|--------------------|-----|----|

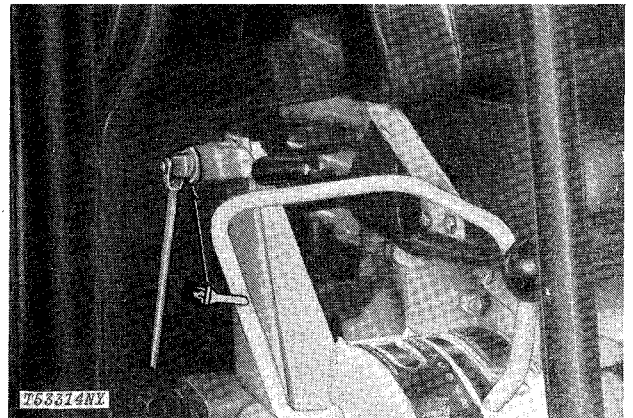

Fig. 23-Blade Control Lever (1 Point)

Lubricate with engine oil.

| | | |
|--------------------|-----|----|
| Lubricant required | Yes | No |
|--------------------|-----|----|

8. Air Intake Hose

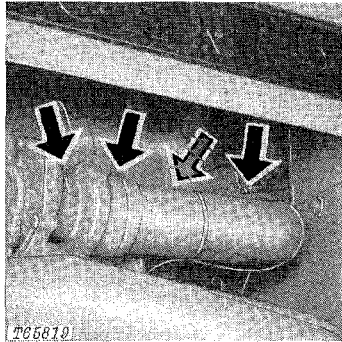

Fig. 24-Hose Clamps

Check clamps on hose connecting air cleaner and engine. Tighten hose clamps. Inspect hose for cracks.

| | | |
|--------------------------------|-----|----|
| <i>Air intake hose checked</i> | Yes | No |
| <i>Loose connections</i> | Yes | No |

9. Alternator-Fan Belt Tension

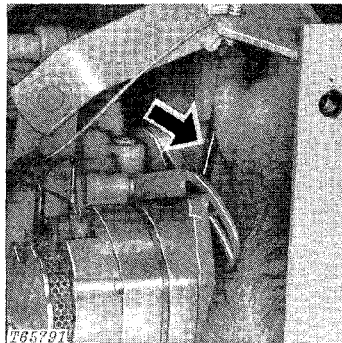

Fig. 25-Alternator Belt

Check alternator belt tension as follows:

If belt tension gauge is used, a force of 17 lb. (8 kg) midway between pulleys should deflect the belt 0.25 in. (6 mm).

If strand tension gauge is used, it should read 90 lb. (41 kg) strand tension.

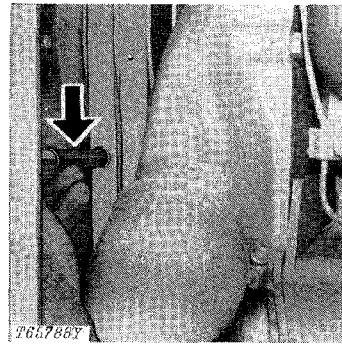

Fig. 25A-Fan Belt

Check fan belt tension as follows:

If belt tension gauge is used, a force of 25 lb. (11 kg) midway between pulleys should deflect the belts 0.75 in. (19 mm).

If strand tension gauge is used, it should read 90 lb. (41 kg) strand tension.

If adjustments are required, see page I-IV-27.

| | |
|--------------------------------|------------------------|
| <i>Alternator belt tension</i> | _____ lbs (kg) tension |
| | _____ inch (mm) flex |

| | |
|-------------------------|------------------------|
| <i>Fan belt tension</i> | _____ lbs (kg) tension |
| | _____ inch (mm) flex |

| | | |
|----------------------------|-----|----|
| <i>Adjustment required</i> | Yes | No |
|----------------------------|-----|----|

10. Engine Speeds

Warm up engine and attach a tachometer in the tachometer drive assembly to check engine speeds.

No-load, fast idle speed should be 2350 rpm. Slow idle should be 800 rpm.

If engine speeds need adjustment, see page 10-10-27.

| | | |
|------------------------------|-----|----|
| <i>Engine speeds checked</i> | Yes | No |
|------------------------------|-----|----|

11. Fuel Filters

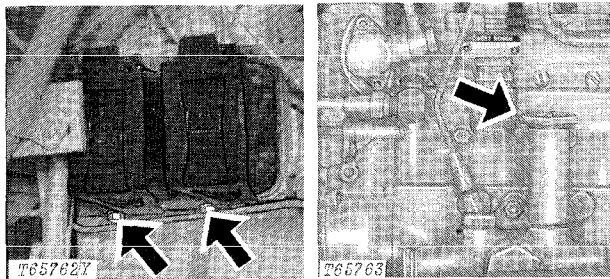

Drain Screws

Primer Lever

Fig. 26-Fuel Filter and Hand Primer

Check fuel filters for sediment. If necessary bleed as follows:

- 1 - Loosen bleed screws.
- 2 - Turn hand primer knob counterclockwise to loosen.
- 3 - Pull hand primer knob up and pump the primer until a solid stream of fuel, free from air bubbles, flows from the bleed plug.
- 4 - Tighten bleed screws.
- 5 - Push hand primer down completely and hand tighten. Turn knob clockwise to tighten.

| | | |
|----------------------------|-----|----|
| Sediment present in filter | Yes | No |
|----------------------------|-----|----|

12. Fuel Tank Sump

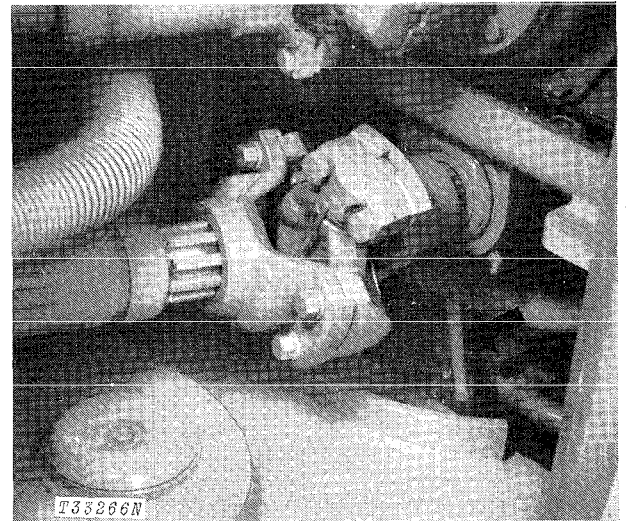

Fig. 27-Fuel Tank Sump Drain Handle

To drain sump:

- 1 - Rotate drain handle clockwise 90° to open drain.
- 2 - Allow fuel to drain for 3 seconds from sump drain.
- 3 - Rotate drain handle counterclockwise 90° to close drain.

| | | |
|------------------------|-----|----|
| Fuel tank sump drained | Yes | No |
|------------------------|-----|----|

13. Indicator Lights and Gauges

When operating your grapple skidder, check the following gauges for correct operation.

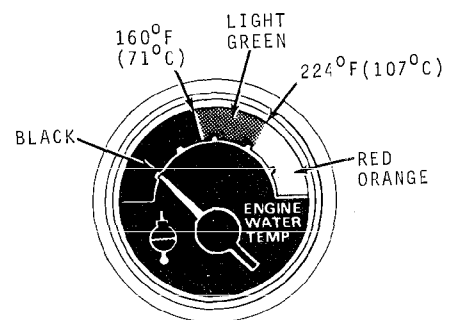
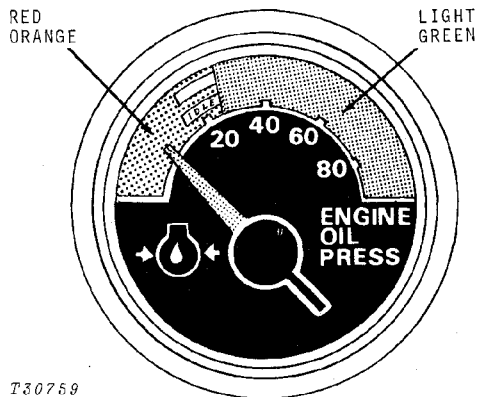

Fig. 28-Engine Coolant Temperature Gauge

Normal operating range is indicated by the light green area of the gauge face. Check cooling system if indicator hand goes into the red-orange zone.



T30759

Fig. 29-Engine Oil Pressure Gauge

Normal operating range is indicated by the light green zone on the gauge face.

If engine oil pressure indicator hand is not in the light green zone, stop engine and check oil level.

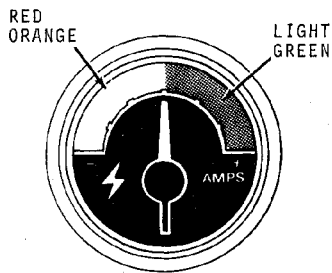

T38571

Fig. 30-Ammeter

Normal operating range is indicated by the light green zone on the gauge face.

If ammeter indicator hand is not in the light green zone, stop engine and check electrical system.

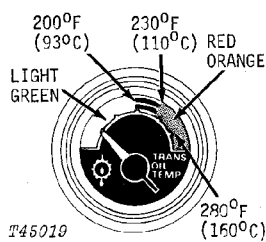

T45019

Fig. 31-Transmission Oil Temperature Gauge

Normal operating range is indicated by the light green zone on the gauge face.

If transmission oil temperature gauge is not in the light green zone, stop engine and check for trash build-up in the grille screen or oil cooler areas.

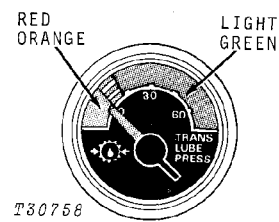

T30758

Fig. 32-Transmission Lube Pressure Gauge

Normal operating range is indicated by the light green zone on the gauge face.

If transmission lube pressure gauge indicator hand is not in the light green zone, stop engine and check for breaks or obstructions in the hydraulic lines or for low oil level.

Gauges and indicator lights operational Yes No

14. Differential Housings

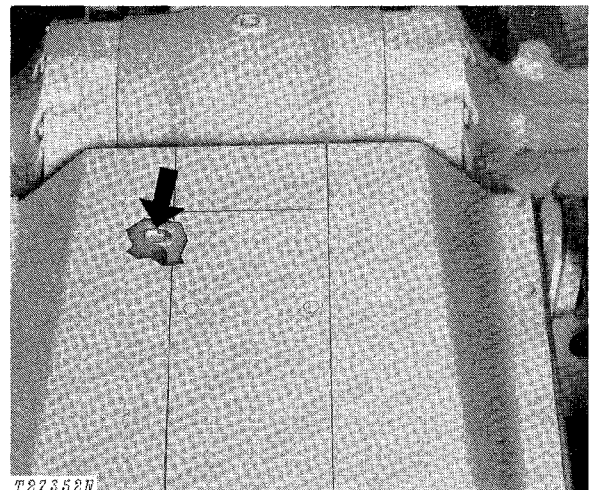

T27352N

Fig. 33-Front Differential Check and Filler Plug

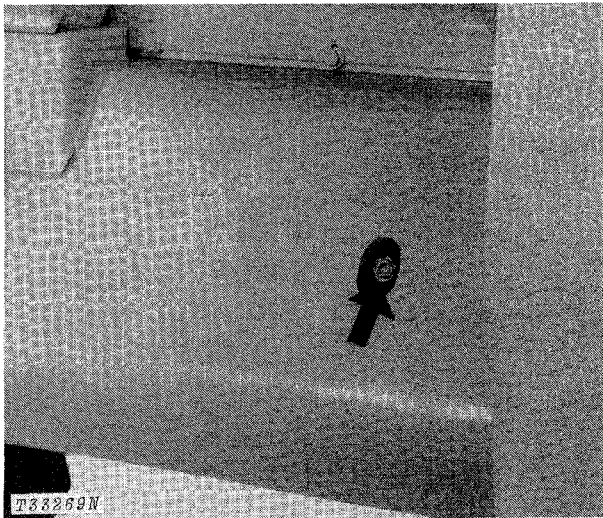

Fig. 34-Rear Differential Check and Filler Plug

Check oil level in front and rear differential housings. If oil level is below oil level plug, add oil as specified on page 10-15-2.

| | | |
|--|-----|----------|
| Differential housing oil level checked | Yes | No |
| Oil added, if any | | qts. (L) |

15. Engine Disconnect Clutch Free Travel

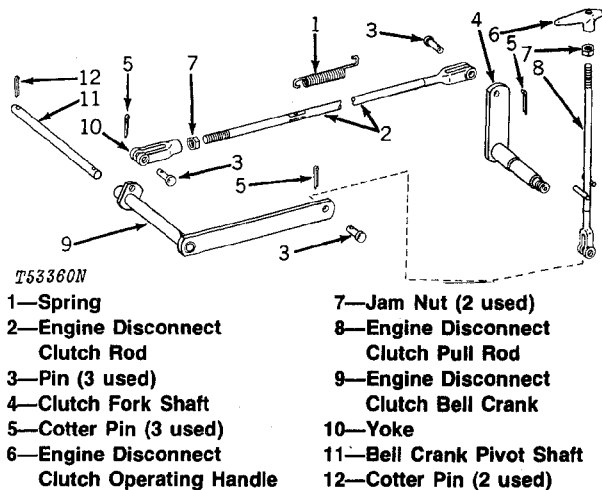

Fig. 35-Engine Disconnect Clutch Linkage

To adjust free travel (with left front platform removed):

- 1 - Assemble engine disconnect clutch operating handle (6) on engine disconnect clutch pull rod (8) approximately 11/16 inch (17.5 mm) (seventeen turns).
- 2 - Tighten jam nut (7) against engine disconnect clutch operating handle.

- 3 - Hold engine disconnect clutch pull rod down against platform.
- 4 - Adjust yoke (10) on engine disconnect clutch rod (2) so pin (3) will just enter hole on engine disconnect clutch bell crank (9). Adjustment is made with lever on clutch fork shaft (4) held as far forward (toward engine) as possible.
- 5 - Tighten jam nut (7).
- 6 - Pull engine disconnect clutch pull rod through platform as far as possible.
- 7 - Attempt to turn the drive line yoke at the rear of the flywheel housing. If it turns freely, no further adjustment is needed.
- 8 - If it does not turn freely unless pull rod is released slightly, steps 3, 4 and 5 must be repeated after engine disconnect clutch operating handle is advanced on rod an additional two turns.
- 9 - Repeat steps 3, 4, 5, and 8 until drive line yoke will turn freely with engine disconnect clutch pull rod pulled through platform as far as possible.

| | | |
|---|-----|----|
| Engine disconnect clutch free travel checked | Yes | No |
| Engine disconnect clutch free travel adjusted | Yes | No |

16. Differential Lock

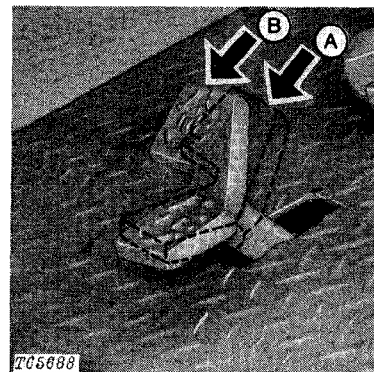

A—Engaged

B—Disengaged

Fig. 36-Differential Lock Pedal

With engine on and differential lock engaged, the steering wheel cannot be rotated more than approximately 20° in each direction.

With engine on and differential lock disengaged, the steering wheel can be rotated approximately 40° in each direction.

| | | |
|---------------------------|-----|----|
| Differential lock checked | Yes | No |
|---------------------------|-----|----|

17. Transmission Shifting

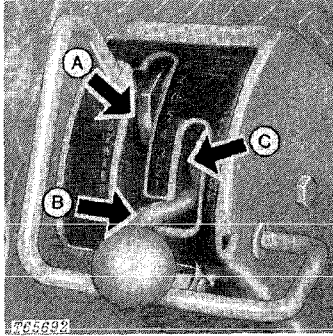

A—Forward B—Neutral C—Reverse

Fig. 37-Transmission Control Lever

Check operation of grapple skidder in all gears.

Transmission checked Yes No

18. Hydraulic Brakes

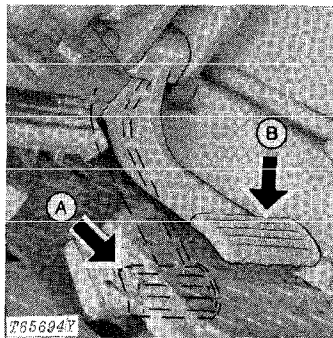

A—Engaged B—Disengaged

Fig. 38-Brake Pedal

Check brake system for leaks or improper operation.

Put grapple skidder in gear and depress brake pedal. Moderate pedal force should hold grapple skidder in place.

If pedal feels spongy or it bottoms out, repair is required, or system may require bleeding (page I-IV-30).

Brakes operational Yes No

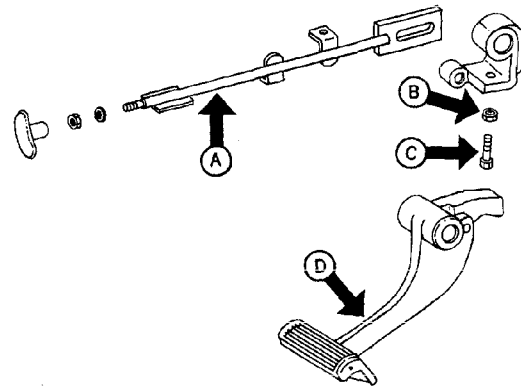

T65082N

A—Brake Lock Rod C—Cap Screw
 B—Nut D—Brake Pedal

Fig. 39-Service Brake Lock Adjustment

Shift to neutral and run engine at 1500 rpm. Depress brake pedal with 100 to 120 lbs. (45 to 54 kg) force. Shift to 3rd speed forward. Slowly release clutch pedal until engine speed lugs down to 1000 rpm. Skidder should not move while engine lugs down.

If skidder moves, adjust as follows:

- 1 - Place brake lock rod (A, Fig. 39) in extended position.
- 2 - Adjust cap screw (C) to just contact brake pedal boss.
- 3 - Lock in place with nut (B).
- 4 - With lock in this position and no force on pedal, move brake lock rod to disengage the locking feature.
- 5 - The brake lock rod should return only part way to the normally disengaged position.
- 6 - Depress brake pedal with more than 100 lbs. (45 kg) force.
- 7 - The brake lock rod should return to the normally disengaged position with a very definite snap.

Brakes operational Yes No

Service brake lock checked Yes No



Suggest:

If the above button click is invalid.

Please download this document

first, and then click the above link

to download the complete manual.

Thank you so much for reading

19. Fire Extinguishers/Fire Suppression

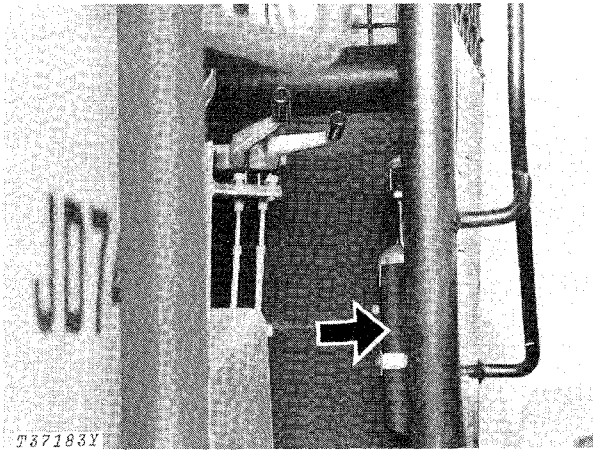

Fig. 40-Fire Extinguisher (1 shown)

Install fire extinguishers on grapple skidder.
Check each extinguisher gauge and/or red indicators for proper charge. If not fully charged, replace canister or recharge.

Replace if corrosion or damage is present.

Connect the manual control mechanism of the fire suppression system before delivery to the customer.

Perform the following procedure:

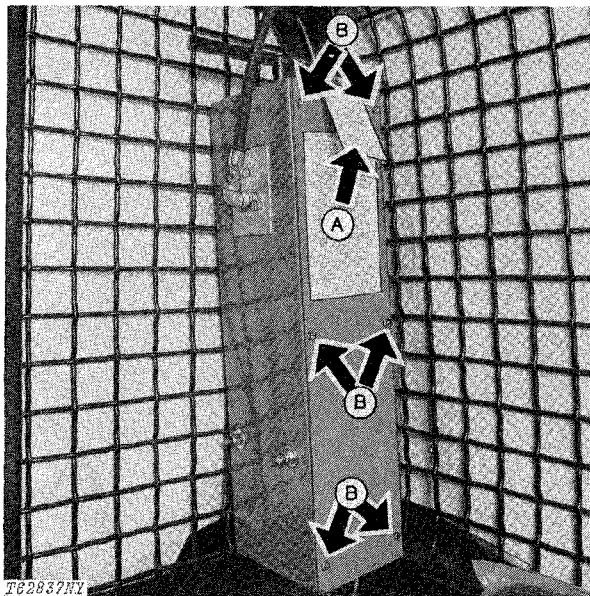

A—Tag

B—Cap Screws

Fig. 41-Removing Tag and Cover

1 - Remove the "IMPORTANT" tag (A, Fig. 41) attached to the top of the control box.

2 - Remove the six cap screws (B) holding the control box cover and remove cover.

Litho in U.S.A.

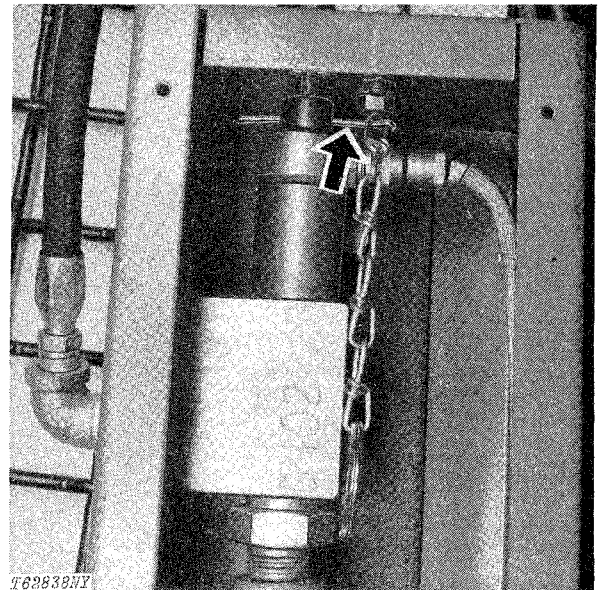

Fig. 42-Removing Pull Pin and Chain

3 - Remove the pull pin and chain from the rear of the cylinder cap.

CAUTION: Do not pull down on the manual override lever with the pull pin and chain removed. Use care when removing and installing pull pin and chain.

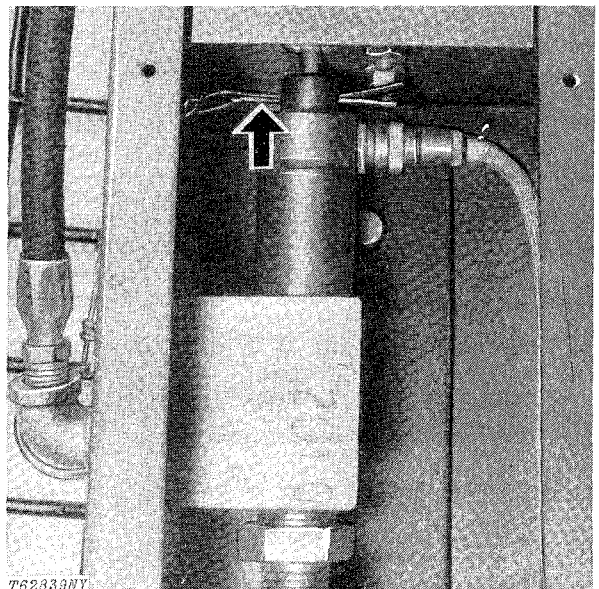

Fig. 43-Installing Pull Pin and Chain

4 - Install the pull pin and chain in the hole in the front of the cylinder cap.

<https://www.ebooklibonline.com>

Hello dear friend!

Thank you very much for reading.

Enter the link into your browser.

The full manual is available for immediate download.

<https://www.ebooklibonline.com>