

JD500 Series-B Loader Backhoe

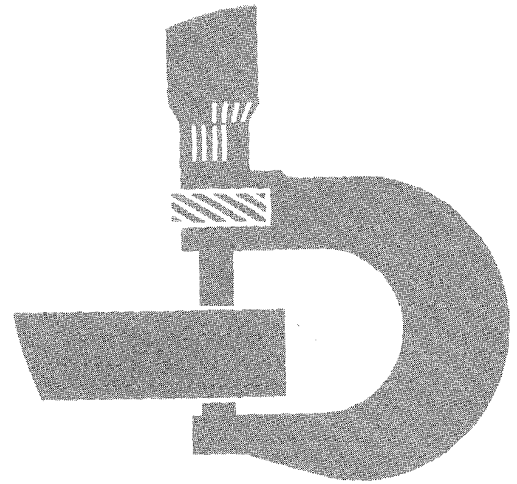

TECHNICAL MANUAL

TM-1024

JD500 SERIES-B LOADER BACKHOE

Technical Manual TM-1024 (Jan-74)

CONTENTS

<p>SECTION 10 - GENERAL</p> <ul style="list-style-type: none"> Group 5 - Specifications Group 10 - Predelivery, Delivery, and After-Sale Services Group 15 - Tune-Up Group 20 - Lubrication Group 25 - Separation <p>SECTION 20 - ENGINE</p> <ul style="list-style-type: none"> Group 5 - General Information and Diagnosis Group 10 - Cylinder Head, Valves, and Camshaft Group 15 - Cylinder Block, Liners, Pistons, and Rods Group 20 - Crankshaft, Main Bearings, Flywheel, and Balancer Group 25 - Lubrication System Group 30 - Cooling System Group 35 - Governor and Speed Control Linkage <p>SECTION 30 - FUEL SYSTEMS</p> <ul style="list-style-type: none"> Group 5 - Diagnosing Malfunctions Group 10 - Diesel Fuel System Group 15 - Gasoline Fuel System <p>SECTION 40 - ELECTRICAL SYSTEM</p> <ul style="list-style-type: none"> Group 5 - Information and Diagrams Group 10 - Charging Circuit Group 15 - Starting Circuit Group 20 - Ignition Circuit Group 25 - Lighting and Accessory Circuits 	<p>SECTION 50 - POWER TRAIN</p> <ul style="list-style-type: none"> Group 5 - Collar-Shift Transmission and PTO Clutches Group 10 - Collar-Shift Transmission Group 15 - Engine Disconnect Clutch Group 20 - Power Shift Transmission Group 25 - Differential Group 30 - Final Drive Group 35 - Collar-Shift PTO Group 40 - Power Shift PTO <p>SECTION 60 - STEERING AND BRAKES</p> <ul style="list-style-type: none"> Group 5 - General Information <p>SECTION 70 - HYDRAULIC SYSTEM</p> <ul style="list-style-type: none"> Group 5 - General Information, Diagnosis, and Tests Group 10 - Hydraulic Components Group 15 - Hydraulic Pumps Group 20 - Power Steering Group 25 - Power Brakes Group 30 - Loader Control Valve Group 35 - Backhoe Control Valve Group 40 - Cylinders <p>INDEX</p>
---	--

The specifications and design information contained in this manual were correct at the time it was printed. It is John Deere's policy to continually improve and update our machines. Therefore, the specifications and design information are subject to change without notice. Wherever applicable, specifications and design information are in accordance with SAE and IEMC standards.

INTRODUCTION

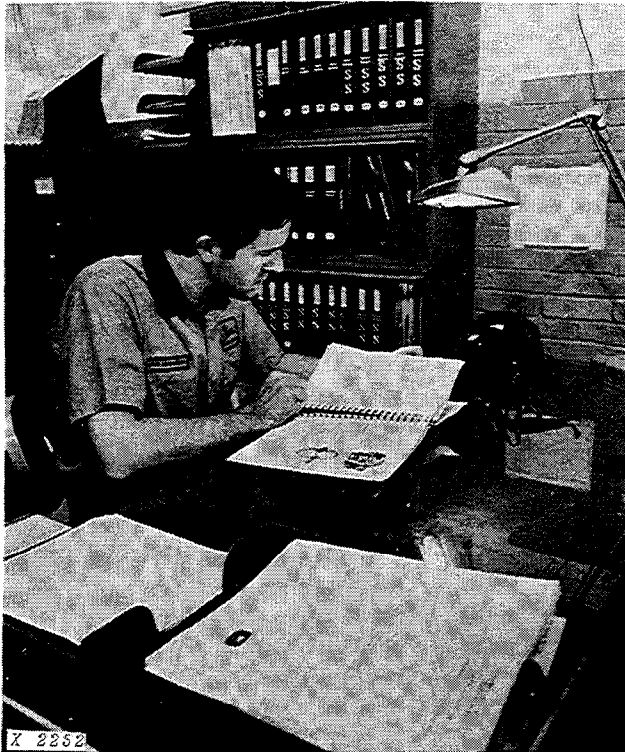

Use FOS Manuals for Reference

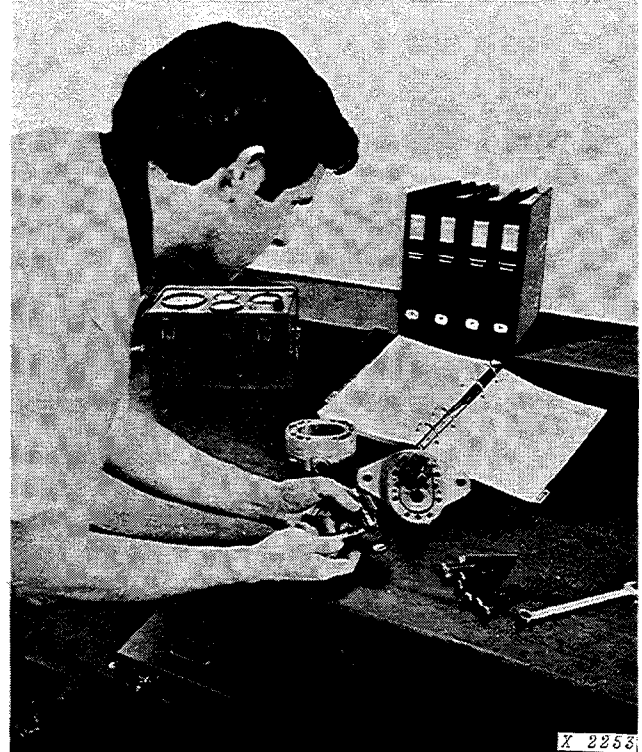

Use Technical Manuals for Actual Service

This technical manual is part of a twin concept of service:

- **FOS Manuals**—for reference
- **Technical Manuals**—for actual service

The two kinds of manuals work as a team to give you both the general background and technical details of shop service.

Fundamentals of Service (FOS) Manuals cover basic theory of operation, *fundamentals* of trouble shooting, *general* maintenance, and *basic* types of failures and their causes. FOS Manuals are for training new men and for reference by experienced men.

Technical Manuals are concise service guides for a *specific* machine. Technical Manuals are on-the-job guides containing only the vital information needed by a journeyman mechanic.



When a serviceman should refer to a FOS Manual for more information, a FOS symbol like the one at the left is used in the TM to identify the reference.

Some features of this technical manual:

- *Table of contents at front of manual*
- *Exploded views showing parts relationship*
- *Photos showing service techniques*
- *Specifications grouped for easy reference*

This technical manual was planned and written for you—a journeyman mechanic. Keep it in a permanent binder in the shop where it is handy. Refer to it whenever in doubt about correct service procedures or specifications.

Using the technical manual as a guide will reduce error and costly delay. It will also assure you the best in finished service work.



This safety alert symbol identifies important safety messages in this manual. When you see this symbol, be alert to the possibility of personal injury and carefully read the message that follows.

<https://www.ebooklibonline.com>

Hello dear friend!

Thank you very much for reading.

Enter the link into your browser.

The full manual is available for immediate download.

<https://www.ebooklibonline.com>

Section 10 GENERAL

CONTENTS OF THIS SECTION

	Page		Page
GROUP 5 - SPECIFICATIONS			
General Machine Specifications	5-1	Greases	20-2
		Storing Lubricants	20-2
GROUP 10 - PREDELIVERY, DELIVERY, AND AFTER-SALE SERVICES			
Predelivery Service	10-1	GROUP 25 - SEPARATION	
Delivery Service	10-3	Removing Backhoe	25-1
After-Sale Inspection	10-4	Removing Loader	25-2
GROUP 15 - TUNE-UP			
Preliminary Engine Testing	15-1	Separating Engine from Clutch Housing with Backhoe Removed	25-3
Engine Tune-Up	15-1	Separating Engine from Clutch Housing with Backhoe Attached	25-4
Final Engine Test	15-4	Removing Engine from Tractor Front End	25-6
Tractor Tune-Up	15-4	Separating Clutch Housing from Power Shift Transmission Case	25-6
GROUP 20 - LUBRICATION			
Lubrication Chart	20-1	Separating Clutch Housing from Collar Shift Transmission Case	25-8
Engine Lubricating Oil	20-2	Removing Final Drive Assembly	25-9
Transmission-Hydraulic Oil	20-2	Torques for Hardware	25-9
		Special Tools	25-10

Group 5

GENERAL MACHINE SPECIFICATIONS

HORSEPOWER (at 2500 engine rpm)
 Net engine flywheel (at 500 ft. altitude and 85° F. temperature); engine equipped with fan, air cleaner, water pump, lubricating oil pump, fuel pump, and alternator:

 Gasoline 77.7 hp.
 Diesel 80.0 hp.

ENGINE

Type . . . 4-stroke cycle, 4-cylinder-in-line, valve-in-head

Bore and Stroke:

 Diesel 4-1/4 x 4-3/4 in.
 Gasoline 4-1/4 x 4-1/4 in.

Displacement:

 Diesel 269 cu. in.
 Gasoline 241 cu. in.

Compression ratio:

 Diesel 16.5 to 1
 Gasoline 7.5 to 1

Firing order 1-3-4-2

Maximum torque:

 Diesel 189 ft-lb
 Gasoline 186 ft-lb

Rpm at maximum torque:

 Diesel 1,400
 Gasoline 1,800

Main bearings:

 Diesel 5
 Gasoline 3

Main bearing length and diameter:

 Diesel and gasoline . . . 1.385 in.-3.375 in.

Valve clearance:

Diesel:

 Intake 0.018 in.
 Exhaust 0.018 in.

Gasoline:

 Intake 0.015 in.
 Exhaust 0.031 in.
 (cold)

Governor:

 Diesel Integral with injection pump.

Engine (continued)

Injection pump timing TDC
Distributor timing:
2200 rpm engine speed . 20 degrees BTDC
Distributor point gap 0.022 in.
Spark plug gap 0.025 in.
Engine speeds:
Normal slow idle 800 rpm
Working range 1500 to 2500 rpm

LUBRICATION SYSTEM

Type Force-feed, pressurized with full-flow oil filter.

FUEL SYSTEM

Diesel . . . Direct injection, inlet metering, distributing-type.
Diaphragm-type fuel pump.
Gasoline . . Pressure system, diaphragm-type fuel pump, single barrel, updraft carburetor.

COOLING SYSTEM

Type . . . Pressurized system with centrifugal pump. Output of pump - 60 gpm.
Engine temperature control . . . Heavy-duty thermostat

ELECTRICAL SYSTEM

Starter, alternator, lights, and accessory voltage 12 volts
Charging system capacity 55 amps
Battery:
Gasoline One, 12-volt, 78-plate 75-ampere-hour
Diesel Two, 6-volt, 75-plate 172-ampere-hour

HYDRAULIC SYSTEM:

Type . . . Closed center, constant pressure. Includes power steering, power brakes and equipment control
Standby pressure 2350 psi

COLLAR-SHIFT TRANSMISSION

Transmission clutch Dry-disk, foot operated, spring loaded type. Single plate (12 in.) with 149 inches of facing area. Torque capacity of 4,490 in-lb at 2,500 engine rpm.

Transmission type . . Constant mesh manual transmission. Eight forward speeds and 2 reverse. Left-hand reverser lever.

Ground speed (at 2500 engine rpm with 18.4-28 tires):

1st.	1.8 mph
2nd	2.9 mph
3rd	3.8 mph
4th.	4.8 mph
5th.	5.9 mph
6th.	7.9 mph
7th.	9.9 mph
8th.	16.2 mph
1st Reverse.	3.6 mph
2nd Reverse	5.7 mph

POWER SHIFT TRANSMISSION

Engine disconnect One dry-disk, lever operated clutch

Transmission type . . Planetary gears, clutches and brakes wet disk, hydraulically actuated, controlled by speed selector. Eight speeds forward and 4 reverse. Left-hand reverser lever.

Ground speed (at 2500 engine rpm with 18.4-28 tires):

1st.	1.7 mph
2nd	2.4 mph
3rd	3.8 mph
4th.	4.9 mph
5th.	6.3 mph
6th.	8.1 mph
7th.	10.8 mph
8th.	18.0 mph
1st Reverse.	2.0 mph
2nd Reverse	2.8 mph
3rd Reverse	4.4 mph
4th Reverse.	5.7 mph

Final Drive

Type Planetary
Power Shift gear reduction
in 1st gear--229 to 1
8th gear--21.8 to 1
Collar-Shift gear reduction
in 1st gear-214 to 1
8th gear-24.2 to 1

STEERING Full power, hydrostatic type.
Provision for manual operation

BRAKES. Hydraulically power actuated,
disk-type operating in oil.
Provision for manual operation
with brake accumulator to
supply oil for an emergency
application.

WHEEL TREAD

Front
8.25-16 70.56 in.
14.00-17.5 70.34 in.
Rear (18.4-28) 65.5 in.

CAPACITIES

Cooling system 19 qt.
Fuel tank (diesel and gasoline) 25 gal.
Engine lubrication (including filter) 8 qt.
Hydraulic system
Transmission reservoir:
Power Shift 11-1/2 gal.
Collar-Shift 8-1/2 gal.
Loader reservoir 3.3 gal.
Backhoe reservoir 14.5 gal.
Mid-mounted pump gear box 0.13 gal.

LOADER

Breakout force 8,600 lb.
Lifting capacity at full height 5,200 lb.
Raising time to full height 5.3 sec.
Bucket dumping time 1.5 sec.
Lowering time 3.5 sec.
Boom cylinders: Double-acting, 3.50 in. bore,
25.63 in. stroke, 1.75 in. dia.
piston rod.
Bucket cylinders: Double-acting, 3.00 in. bore,
25.75 in. stroke, 1.75 in. dia.
piston rod.

BACKHOE

Swing arc 180 deg.
Digging force (24-in.
standard bucket) 13,200 lb.
Reach from center of rear axle using
24-inch standard bucket 25 ft. 11 in.
Stabilizer spread 13 ft. 4 in.
Boom cylinder 5.50 in. x 40.56 in.;
Piston rod dia. 2.50 in.
Crowd cylinder 5.50 in. x 37.50 in.;
Piston rod diameter 2.50 in.
Bucket cylinder 4.00 in. x 37.50 in.;
Piston rod dia. 2.50 in.
Swing cylinder 4.50 in. x 9.88 in.;
Piston rod dia. 2.00 in.;
Built-in automatic
swing brake.
Stabilizer cylinders 4.50 in. x 21.50 in.;
Piston rod dia. 2.50 in.

LOADER BACKHOE DIMENSION

Wheelbase	82 in.
Overall length	274 in.
Overall height (to top of canopy) . . .	103 in.
Transport height (to dipperstick) .	13 ft. 3 in.
Height to top of hood	64 in.
Overall width	93 in.
Ground clearance	8-1/2 in.
Turning radius (brakes released) . . .	147 in.
Turning clearance circle (loader hinge pin 3 ft. above ground level, bucket rolled back and brakes released). 30 ft. dia.	
Curb clearance circle:	
With brakes	290 in.
Without brakes	320 in.
No. of turns (far left to far right) . .	4.67

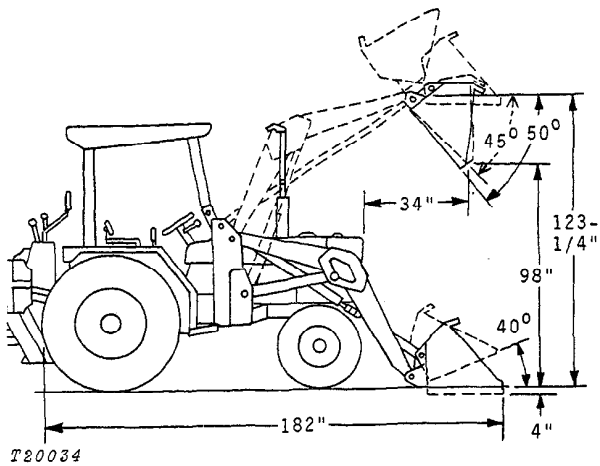

Loader Equipped with 1-1/8 Yard Bucket and 18.4-28 Rear Tires

SHIPPING WEIGHT (Equipped with Power Shift transmission, less fuel and ballast. Deduct 255 lbs. if equipped with a Collar-Shift transmission. If equipped with multi-position backhoe, add 800 lbs. Loader equipped with a 1-1/8 cu. yd. loader bucket and 24-inch backhoe bucket):

Diesel	19,100 lb.
Gasoline	19,000 lb.
Roll-Gard (includes canopy)	430 lb.
Loader bucket (1-1/8 cu. yd.)	824 lb.

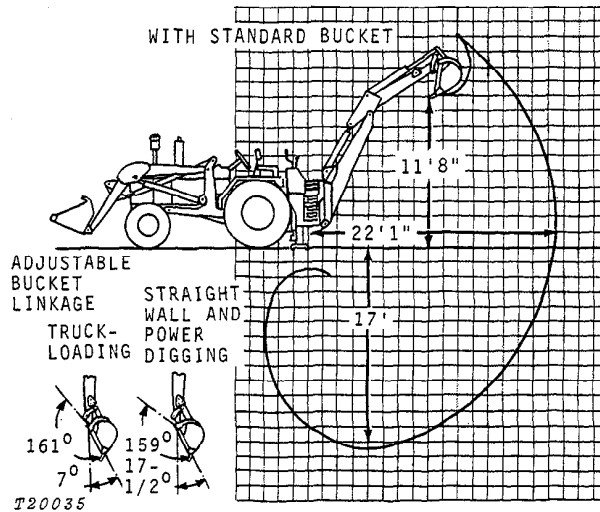

Backhoe Equipped with 24 In. Standard Bucket

(Specifications and design are subject to change without notice. Wherever applicable, specifications are in accordance with IEMC and SAE Standards.)

Group 10 PREDELIVERY, DELIVERY, AND AFTER SALE SERVICES

PREDELIVERY SERVICE

Because of the shipping factors involved, plus extra finishing touches that are necessary to promote customer satisfaction, proper predelivery service is of prime importance to the dealer.

Machines shipped from the factory with the alternator completely disconnected require an AR47860 Auxiliary Ignition Battery Kit to supply power for the ignition system (gasoline models) and the fuel shutoff solenoid (all models). The adapter on the battery kit harness plugs into the cigar lighter. Be sure to read the instructions

attached to the machine before starting the engine.

After completing the factory-recommended predelivery services listed on the predelivery tag, remove the tag from the machine and file it with the shop order for the job. The tag will then serve as a basis for certifying that the machine has received the proper predelivery service when that portion of the customer's John Deere Delivery Receipt is completed.

TEMPORARY MACHINE STORAGE

Service	Specification	Reference
Check radiator for coolant loss and antifreeze protection.	1-1/2 inches above baffle.
Drain fuel system (gasoline).	Operator's manual.
Remove and store battery electrolyte.	Store at room temperature.
Reduce shipping pressure of tires.	Operator's manual
Cover machine and tires for protection and cleanliness.

BEFORE DELIVERING MACHINE

Cooling System

Inspect radiator for coolant loss.	1-1/2 inches above baffle.
Check antifreeze protection.

Electrical System

Install electrolyte and charge batteries.	FOS-20 Manual
Stamp date code on battery.	FOS-20 Manual
Connect alternator. Do not attempt to polarize. Remove resistor if present.	Section 40, Group 5
Install light switch knob.
Clean terminals and connect battery cables.	Section 40, Group 10

BEFORE DELIVERING MACHINE—Continued

Service	Specification	Reference
<u>Tires and Wheels</u>		
Adjust pressure of tires.	Operator's manual
Check front wheel hub bolts and rear wheel retainer nuts.	Front hub bolts - 275 ft-lbs Wheel retainer nuts - 275 ft-lbs	Operator's manual
<u>Lubrication</u>		
Check crankcase oil level.	To upper marks on dipstick.	Operator's manual
Check transmission-hydraulic system oil level.	To top of "SAFE" range on dipstick. Type 303 Special-Purpose Oil.	Operator's manual
Lubricate grease fittings.	SAE multipurpose-type grease	Operator's manual
Check distributor lubrication.	Distributor cam lubricant	Section 40, Group 20
<u>Engine</u>		
Check air cleaner.	Operator's manual
Fill fuel tank and start engine.	Capacity - 25 U.S. gallons	Operator's manual
Check operation of lights, gauges, and indicator lamps.	Operator's manual
Check governor linkage for free operation.	Section 20, Group 35
Check engine timing.	Section 40, Group 20
Check engine idle speeds.	Section 20, Group 35
<u>Operation</u>		
Shift transmission through all speeds.	Operator's manual
Check inching pedal for smooth engagement.
Check engine disconnect clutch.	No tendency for machine to creep when clutch is disengaged (2-1/4 inch average free travel)	Section 50, Group 15
Check power takeoff operation.	Operator's manual
Check differential lock operation.	Operator's manual

BEFORE DELIVERING MACHINE—Continued

Service	Specification	Reference
Check operation of steering, brakes, and hydraulic operations.	Operator's manual
Check seat operation.	Operator's manual
<u>General</u>		
Tighten accessible nuts and cap screws.
Clean machine and touch up paint.

DELIVERY SERVICE

A thorough discussion of the operation and service of a new machine at the time of delivery helps to assure complete customer satisfaction. Proper delivery should be an important phase of a dealer's program. A portion of the John Deere Delivery Receipt emphasizes the importance of proper delivery service.

It is a well-known fact that many complaints have arisen simply because the owner was not shown how to operate and service his new machine properly. Enough time should be devoted, at the customer's convenience, to introducing the owner to his new machine and explaining to him how to operate and service it.

The following procedure is recommended before the serviceman and owner complete the delivery acknowledgments portion of the delivery receipt.

Using the machine operator's manual as a guide, be sure that the owner understands these points thoroughly:

1. Controls and instruments.
2. How to start and stop the engine.
3. The importance of the break-in period.
4. How to use liquid or cast-iron ballast.
5. All functions of the hydraulic system.
6. The importance of safety.
7. The importance of lubrication and periodic services.

After explaining and demonstrating the above features, have the owner sign the delivery receipt and give him the operator's manual.

AFTER SALE INSPECTION

The purchaser of a new JD500 Series-B Loader Backhoe is entitled to a free inspection at some mutually agreeable time within the warranty period after the equipment has been "run in." The terms of this after-sale inspection are outlined on the back of the customer's John Deere Delivery Receipt.

The purpose of this inspection is to make sure that the customer is receiving satisfactory performance from his machine. At the same time, the inspection should reveal whether or not the machine is being operated, lubricated, and serviced properly.

If the recommended after-sale service inspection is followed, the dealer can eliminate a needless volume of service work by preventing minor irregularities from developing into serious problems later on. This will promote strong dealer-customer relations and present the dealer an opportunity to answer questions that may have arisen during the first few days of operation. During the inspection service, the dealer has the further opportunity of promoting the possible sale of other new equipment.

The following inspection program is recommended within the first 100 hours of machine operation.

INSPECTION PROCEDURE

Service	Specification	Reference
<u>Cooling System</u>		
Check radiator coolant level.	1-1/2 inches above baffle.
Clean external surface of radiator core.
Check hoses and connections for leaks.
<u>Fuel System</u>		
Remove water and foreign matter from fuel pump and filter sediment bowls.	Operator's manual
Bleed fuel system.	Operator's manual
Tighten loose connections and check entire system for leaks. Correct if necessary.
Check air cleaner cup, element, and unloading valve. Clean element if necessary.	Operator's manual

INSPECTION PROCEDURE—Continued

Service	Specification	Reference
<u>Electrical System</u>		
Check specific gravity of battery(s).	Full charge - 1.260 to 1.290 at 80° F.	Operator's manual
Check level of battery electrolyte.	To bottom of filler neck in each cell.	Operator's manual
Check belt tension.	1-inch deflection with a 20-pound force.	Operator's manual
Start engine and check action of starter, lights, and indicator lamps.	Operator's manual
<u>Lubrication</u>		
Check crankcase oil level.	To upper marks on dipstick.	Operator's manual
Check transmission-hydraulic system oil level.	In "SAFE" range on dipstick. Use John Deere Type 303 Special-Purpose Oil.	Operator's manual
Check mid-pump gear box oil level.	To level with plug.	Operator's manual
Check distributor lubrication.	Distributor cam lubricant.	Section 40, Group 20
<u>Engine</u>		
Check valve clearance.	Intake: Diesel - 0.018 in. Gasoline - 0.015 in.	Operator's manual
	Exhaust: Diesel - 0.018 in. Gasoline - 0.028 in. (hot)	
Check engine speed under load, fuel consumption, and horsepower.	Specification.	Group 15 of this Section.
<u>Clutches and Differential Lock</u>		
Shift transmission through all speeds.	Operator's manual
Check transmission clutch free travel (Collar-Shift transmission).	Approximately 1-1/2-inch free travel.	Operator's manual
Check engine disconnect clutch (Power Shift transmission).	No tendency for machine to creep when clutch is disengaged (2-1/4-in. average free travel).	Section 50, Group 15

INSPECTION PROCEDURE—Continued

Service	Specification	Reference
Check differential lock operation.	Operator's manual
<u>Hydraulic System</u>		
Check all hydraulic function operations, fittings, and hose positions.	Operator's manual
Check power steering.	Smooth, easy operation.	Section 60, Group 5
Check operation of power brakes and accumulator.	Bleed the power brakes after every 200 hours of operation or whenever brake pedal travel exceeds 3 inches immediately after stopping the engine.	Operator's manual
Check operation of hydraulic function accumulator.	Operator's manual
<u>Nuts and Cap Screws</u>		
Tighten accessible nuts and cap screws that seem to require adjustment.



Suggest:

If the above button click is invalid.

Please download this document

first, and then click the above link

to download the complete manual.

Thank you so much for reading

Group 15 TUNE-UP

GENERAL INFORMATION

Before tuning up a tractor, determine whether a tune-up will restore operating efficiency. When there is doubt, the following preliminary tests

will help to determine if the engine can be tuned-up. If the condition is satisfactory, proceed with the tune-up. Choose from the following procedures only those necessary to restore the unit.

PRELIMINARY ENGINE TESTING

Operation	Specification	Section-Group Reference
Dynamometer Test (at 2500 engine rpm)	Compare with previous recorded output; compare with output after tune-up	FOS 30 Manual, Chapter 12
Compression Test		
Diesel	400 psi at 275 rpm	FOS 30 Manual, Chapter 12
Gasoline	180 psi at 170 rpm	
Vapor Flow Test (average engine condition)		
Diesel	Normal blowby - 60-100 cu. ft./hr. Excessive blowby - 150 cu. ft./hr.	FOS 30 Manual, Chapter 12
Gasoline	Normal blowby - 30-60 cu. ft./hr. Excessive blowby - 100 cu. ft./hr.	
Manifold Depression Test (gasoline)	18-20 inches Mercury	FOS 30 Manual, Chapter 12
Engine Coolant Check Test	No air bubbles or oil film in radiator	FOS 30 Manual, Chapter 12

ENGINE TUNE-UP

Operation	Specification	Section-Group Reference
Air Intake System		
Service air cleaner and check system for leaks	FOS 30 Manual, Chapter 12
Check system for restrictions using water manometer (inches of water)	FOS 30 Manual, Chapter 12
Normal reading:		
Diesel - with precleaner and extension	9 in. at 2500 rpm
without precleaner and extension	4 in. at 2500 rpm
Gas - with precleaner and extension	7 in. at 2500 rpm (full load)
without precleaner and extension	3 in. at 2500 rpm (full load)
Maximum permitted reading	20 in. at 2500 rpm (full load)
Check restriction indicator light operation	19-21 in. at 2500 rpm (full load)

<https://www.ebooklibonline.com>

Hello dear friend!

Thank you very much for reading.

Enter the link into your browser.

The full manual is available for immediate download.

<https://www.ebooklibonline.com>