

Hydraulic Trencher TR36, TR48, and TR60 for 240, 250, 260, 270 and 4475, 5575, 6675, 7775, 8875 Skid Steers

(Serial No. 100100 –)

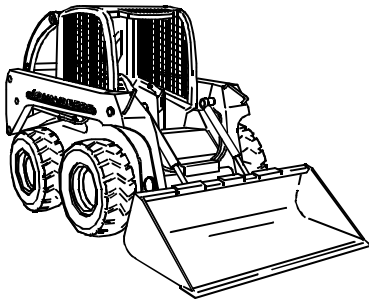

OPERATOR'S MANUAL

John Deere
Commercial Worksite Products

OMKV16794 I9

North American Version
Litho in U.S.A
English

INTRODUCTION

THANK YOU for purchasing a John Deere product.

Read this manual and your vehicle manual thoroughly. Failure to do so could result in personal injury or equipment damage.

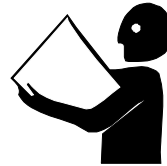

This manual should be considered a permanent part of your attachment and should remain with the attachment when you sell it.

Measurements in this manual are metric units and their U.S. customary equivalents. RIGHT-HAND and LEFT-HAND sides are determined by facing in the direction the machine will travel when going forward. When you see a broken line arrow (----->), it indicates the part it is pointing to is hidden.

Product warranty is provided as part of John Deere's support program for customers who operate and maintain their equipment as described in this manual. The product warranty is explained on the warranty certificate you received from your dealer.

Record identification numbers below. Be sure to record all the numbers to help in tracing the attachment if it is stolen. You also need to give these numbers to your authorized John Deere skid steer dealer when you order parts.

DATE OF PURCHASE:

DEALER NAME:

DEALER PHONE:

SERIAL NUMBER (A):

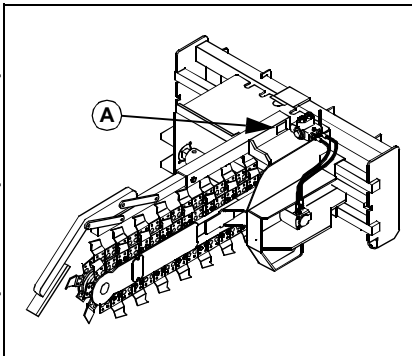

TABLE OF CONTENTS

	Page
Safety Signs	1
Preparing the Vehicle	2
Installing	3
Removing	8
Operating	10
Service Machine Safely	20
Service Interval Chart	23
Service	24
Troubleshooting	28
Storing Machine	29
Assembly	30
Specifications	32
Warranty	34
Index	35
John Deere Service Literature	38

All information, illustrations and specifications in this manual are based on the latest information at the time of publication. The right is reserved to make changes at any time without notice.

COPYRIGHT© 1999
John Deere Commercial Worksite Products
Knoxville, Tennessee

<https://www.ebooklibonline.com>

Hello dear friend!

Thank you very much for reading.

Enter the link into your browser.

The full manual is available for immediate download.

<https://www.ebooklibonline.com>

SAFETY SIGNS

Safety-Alert Symbol

Read and recognize safety information. Be alert to the potential for personal injury when you see this safety-alert symbol.

On your attachment safety labels, the words DANGER, WARNING, and CAUTION are used with this safety-alert symbol. DANGER identifies the most serious hazards. In this manual, the word CAUTION and this symbol call attention to safety messages.

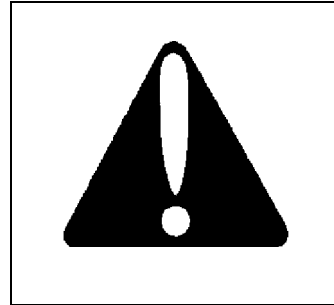

Attachment Safety Labels

DANGER: Avoid Injury or Death

- Read and understand operator's manual before operating or servicing machine.
- Know location of underground utilities before digging.
- Keep bystanders 6 m (20 ft.) away from attachment.

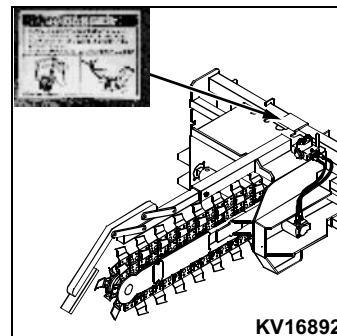

DANGER: Rotating Part Hazard

- Entanglement in rotating parts can cause serious injury or death.
- Keep hands, feet, and clothing away from rotating parts.
- Keep bystanders away.
- Stop engine before servicing machine.

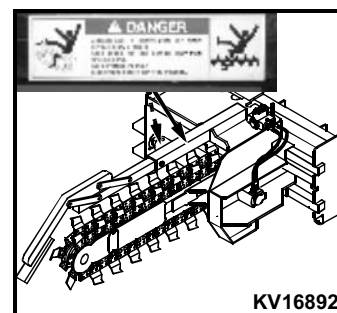

PREPARING THE VEHICLE

Skid Steer Equipment Requirements

Model 4475 skid steers also require boom hydraulics and hand control handle kits for trencher operation. If your unit is not equipped with this equipment, see your authorized John Deere skid steer dealer.

Worksite Pro™ Trencher TR60 Only:

The skid steer must be equipped with High-Flow Hydraulics.

Ballasting for All Models:

Rear ballast is not required to operate the trencher, but will enhance vehicle stability. Ballasting kits are available at your authorized John Deere skid steer dealer.

INSTALLING

Park Skid Steer Safely

1. Stop skid steer on firm, level surface. Do not park on a slope.
2. Lower boom to the ground.
3. Engage the park brake.
4. Stop the engine. Release the seat belt.
5. Remove the key.
6. Before you leave the operator's seat, wait for engine and all moving parts to STOP.

Avoid High Pressure Fluids

- Escaping fluid under pressure can penetrate the skin causing serious injury. Avoid the hazard by relieving pressure before disconnecting hydraulic or other lines. Tighten all connections before applying pressure.
- Search for leaks with a piece of cardboard. Protect hands and body from high pressure fluids.
- If an accident occurs, see a doctor immediately. Any fluid injected into the skin must be surgically removed within a few hours or gangrene may result. Doctors unfamiliar with this type of injury should reference a knowledgeable medical source. Such information is available from Deere & Company Medical Department in Moline, Illinois, U.S.A., 1-800-822-8262.



INSTALLING

Using QUIK-TATCH™ Attachment Mounting System



CAUTION: To avoid injury:

- **DO NOT** try to latch or unlatch handles from the cab.
- **Be careful not to pinch hands between latch handle and step or latch handle and attachment.**

To install hydraulic trencher:

1. Stop skid steer, lower boom, engage park brake, stop engine, release seat belt, remove key, and exit skid steer.
2. Lift latch handles (A) up to the UNLATCHED position. Be sure the latch handles are all the way up so the lock pins are fully retracted.
3. Enter skid steer, fasten seat belt, start the engine, and disengage park brake.
4. Tilt QUIK-TATCH™ mounting plates (B) forward.

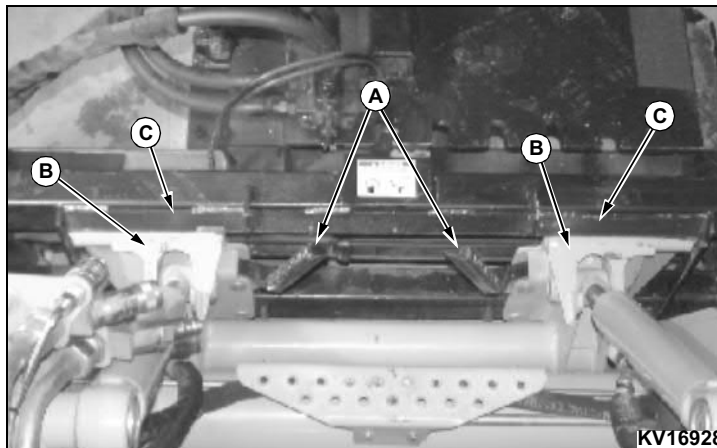

5. Drive forward, raise boom, and guide the top of the mounting plates into the attachment mounting brackets (C).
6. Raise and tilt back the mounting plates. The back of the attachment should rest against the front of the mounting plate.

INSTALLING

7. When the attachment is fully supported, lower the boom until the boom is resting on the boom stops.

8. Tilt the attachment out, stopping with the bottom edge of attachment about 50 mm (2 in.) from the ground.

9. Engage the park brake, turn off the engine, release seat belt, and exit the skid steer.

10. Push the two latch handles (A) down to lock the attachment to the QUIK-TATCH™ mounting plates.

11. Enter the skid steer, fasten the seat belt, start the engine, and disengage the park brake.

12. Activate the lift cylinders to raise attachment and extend bucket cylinders to tilt attachment at a slight downward angle so that the bottom of the QUIK-TATCH™ is visible.

13. Visually inspect the attachment mechanism to verify that pins are fully engaged in slots on the back of the attachment.

14. Connect hydraulic lines.

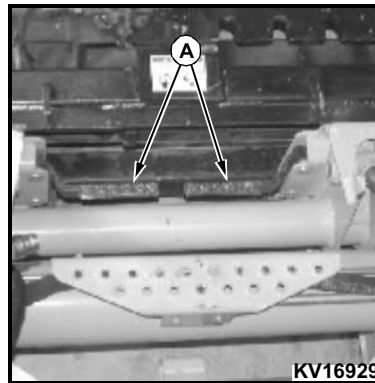

CAUTION: To avoid injury, be sure pins and latch handles are secure before operating boom and bucket.

If attachment is not securely latched, follow the steps to remove and then repeat installation procedure.

INSTALLING

Attaching Trencher Hydraulic Lines

IMPORTANT: Ensure hydraulic hoses are routed properly as described in Assembly section.



CAUTION: Relieve hydraulic pressure before connecting or disconnecting auxiliary hydraulic lines.

To relieve hydraulic line pressure:

200 Series

1. Sit in operator's seat.
2. Unlock handle from neutral position:
 - Turn key (A) to the right.
3. Move handle down toward seat and up away from seat several times.

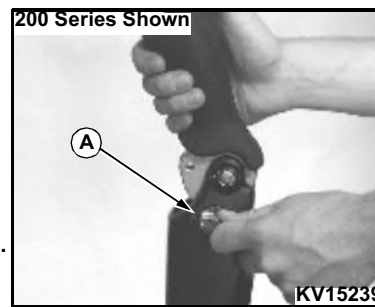

75 Series

1. Sit in operator's seat.
2. Unlock handle from neutral position:
 - Push lock pin (B) down.
3. Move handle down toward seat and up away from seat several times.

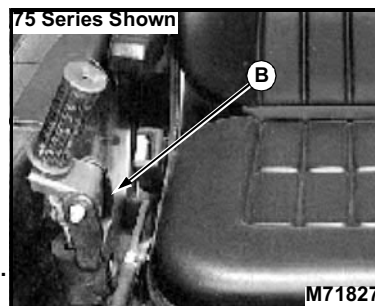

INSTALLING

To attach hydraulic lines:

1. Connect quick-disconnect couplers from trencher to quick-disconnect couplers on skid steer auxiliary hydraulic oil lines.
2. Push couplers together with a firm continuous motion until couplers lock into place.



IMPORTANT: Inspect all lines and hoses for freedom of movement.

REMOVING

Park Skid Steer Safely

1. Stop skid steer on firm, level surface. Do not park on a slope.
2. Lower boom to the ground.
3. Engage the park brake.
4. Stop the engine. Release the seat belt.
5. Remove the key.
6. Before you leave the operator's seat, wait for engine and all moving parts to STOP.

Removing Trencher from Skid Steer

1. Roll bucket cylinders forward or curl back, as necessary, so that trencher is level with the ground.
2. Lower boom all the way down.
3. Engage park brake, and stop the engine.
4. Relieve hydraulic line pressure by actuating control handle all the way down toward the seat and all the way up away from the seat several times.
5. Remove the key. Release the seat belt. Exit the skid steer. Disconnect hydraulic lines from skid steer.



REMOVING

IMPORTANT: Connect the two hydraulic lines from the trencher to each other.
This will ensure connectors stay clean and allows hydraulic fluid to circulate due to thermal expansion.

6. To connect the hydraulic lines together:

- Hold hydraulic lines and place on your knees.
- Align the fittings.
- Using your arms and legs, push the hydraulic fittings together until the quick-disconnect couplers lock together.

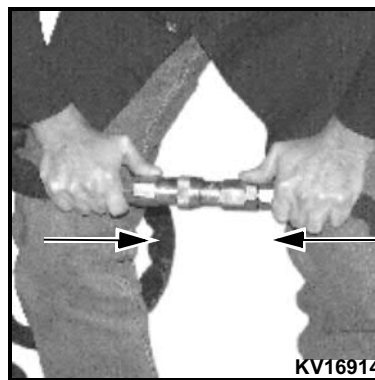

7. Lift handles (A) on QUIK-TATCH™ to release mounting plates from attachment.

8. Enter the skid steer, fasten seat belt, start the engine, and disengage park brake.

9. Slowly roll the bucket cylinders forward while slowly backing away from the attachment.

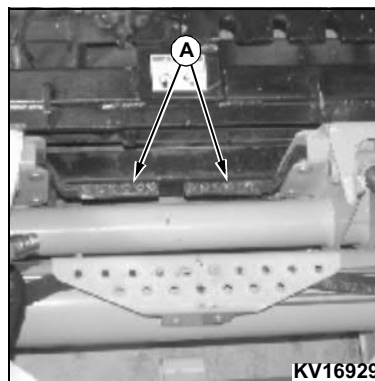



Suggest:

If the above button click is invalid.

Please download this document

first, and then click the above link

to download the complete manual.

Thank you so much for reading

OPERATING

SAFETY

Operator Training Required



- Study the Skid Steer Operator's Manual. Know location and function of all controls. Know how to operate the skid steer before using this attachment.
- Study operation section of this manual before operating this attachment. Know location and function of all controls.
- Operate machine in an open, unobstructed area under the direction of an experienced operator.
- Operator experience is required to learn the moving, stopping, turning, and other operating characteristics of this attachment.



CAUTION: Avoid death. Contacting a utility line with the trencher can cause electrocution and or gas explosion resulting in death.

Call the utility companies and have them plot out all of their lines before starting any trenching operation.

To avoid injury during operation do not permit bystanders within 6 m (20 ft) of the trencher.

Back up carefully. An operator must always look to each side and to the rear when backing up.

<https://www.ebooklibonline.com>

Hello dear friend!

Thank you very much for reading.

Enter the link into your browser.

The full manual is available for immediate download.

<https://www.ebooklibonline.com>