

GX70, GX75, GX85, SX85 GX95, SRX75 and SRX95 Riding Mowers

TECHNICAL MANUAL

**John Deere
Worldwide Commercial and
Consumer Equipment Division**

**TM1491 (JULY99)
Replaces TM1491 (01JAN97)**

This technical manual is written for an experienced technician and contains sections that are specifically for this product. It is a part of a total product support program.

The manual is organized so that all the information on a particular system is kept together. The order of grouping is as follows:

- Table of Contents
- General Diagnostic Information
- Specifications
- Electrical Wiring Harness Legend
- Component Location
- System Schematic
- Wiring Harness
- Troubleshooting Chart
- Theory of Operation
- Diagnostics
- Tests & Adjustments
- Repair

Note: Depending on the particular section or system being covered, not all of the above groups may be used.

Each section will be identified with a symbol rather than a number. The groups and pages within a section will be consecutively numbered.

We appreciate your input on this manual. To help, there are postage paid post cards included at the back. If you find any errors or want to comment on the layout of the manual please fill out one of the cards and mail it back to us.

Safety 

Specifications and Information 

Engine 

Electrical 

Power Train 

Steering 

Brakes 

Attachments 

Miscellaneous 

All information, illustrations and specifications in this manual are based on the latest information available at the time of publication. The right is reserved to make changes at any time without notice.

COPYRIGHT© 1999
Deere & Co.
John Deere Worldwide Commercial and
Consumer Equipment Division
Horicon, WI
All rights reserved
Previous Editions
COPYRIGHT© 1997,
1992, 1991, 1990, 1989, and 1988



RECOGNIZE SAFETY INFORMATION



This is the safety-alert symbol. When you see this symbol on your machine or in this manual, be alert to the potential for personal injury.

Follow recommended precautions and safe servicing practices.

Understand Signal Words

A signal word—DANGER, WARNING, or CAUTION—is used with the safety-alert symbol. DANGER identifies the most serious hazards.

DANGER or WARNING safety signs are located near specific hazards. General precautions are listed on CAUTION safety signs. CAUTION also calls attention to safety messages in this manual.

REPLACE SAFETY SIGNS

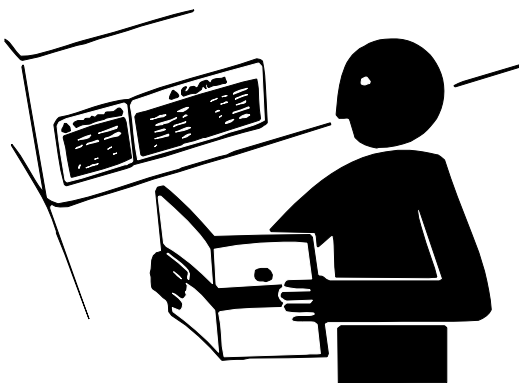

Replace missing or damaged safety signs. See the machine operator's manual for correct safety sign placement.

HANDLE FLUIDS SAFELY—AVOID FIRES

Be Prepared for Emergencies

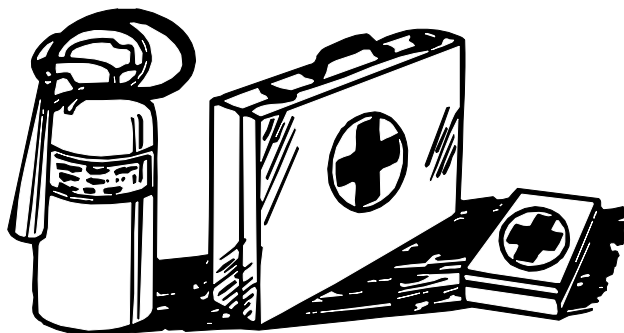

When you work around fuel, do not smoke or work near heaters or other fire hazards.

Store flammable fluids away from fire hazards. Do not incinerate or puncture pressurized containers.

Make sure machine is clean of trash, grease, and debris.

Do not store oily rags; they can ignite and burn spontaneously.

Be prepared if a fire starts.

Keep a first aid kit and fire extinguisher handy.

Keep emergency numbers for doctors, ambulance service, hospital, and fire department near your telephone.

<https://www.ebooklibonline.com>

Hello dear friend!

Thank you very much for reading.

Enter the link into your browser.

The full manual is available for immediate download.

<https://www.ebooklibonline.com>

USE CARE IN HANDLING AND SERVICING BATTERIES

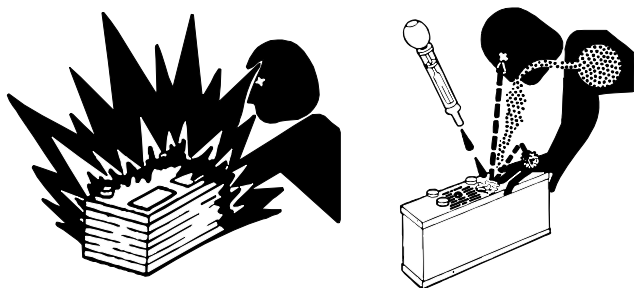

Prevent Battery Explosions

- Keep sparks, lighted matches, and open flame away from the top of battery. Battery gas can explode.
- Never check battery charge by placing a metal object across the posts. Use a voltmeter or hydrometer.
- Do not charge a frozen battery; it may explode. Warm battery to 16°C (60°F).

Prevent Acid Burns

- Sulfuric acid in battery electrolyte is poisonous. It is strong enough to burn skin, eat holes in clothing, and cause blindness if splashed into eyes.
- **Avoid acid burns by:**
 1. Filling batteries in a well-ventilated area.
 2. Wearing eye protection and rubber gloves.
 3. Avoiding breathing fumes when electrolyte is added.
 4. Avoiding spilling or dripping electrolyte.
 5. Using proper jump start procedure.
- **If you spill acid on yourself:**
 1. Flush your skin with water.
 2. Apply baking soda or lime to help neutralize the acid.
 3. Flush your eyes with water for 10—15 minutes.
 4. Get medical attention immediately.
- **If acid is swallowed:**
 1. Drink large amounts of water or milk.
 2. Then drink milk of magnesia, beaten eggs, or vegetable oil.
 3. Get medical attention immediately.

USE CARE AROUND HIGH-PRESSURE FLUID LINES



Avoid High-Pressure Fluids

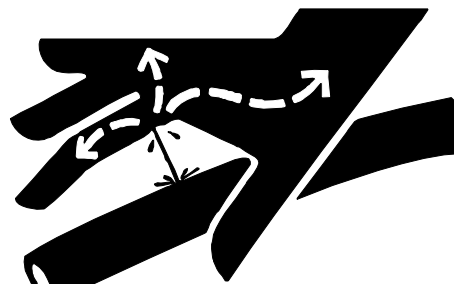

Escaping fluid under pressure can penetrate the skin causing serious injury.

Avoid injury from escaping fluid under pressure by stopping the engine and relieving pressure in the system before disconnecting or connecting hydraulic or other lines. Tighten all connections before applying pressure.

Search for leaks with a piece of cardboard. Protect hands and body from high-pressure fluids.

If an accident occurs, see a doctor immediately. Any fluid injected into the skin must be surgically removed within a few hours or gangrene may result. Doctors unfamiliar with this type of injury should reference a knowledgeable medical source. Such information is available from Deere & Company Medical Department in Moline, Illinois, U.S.A.

Avoid Heating Near Pressurized Fluid Lines



Flammable spray can be generated by heating near pressurized fluid lines, resulting in severe burns to yourself and bystanders. Do not heat by welding, soldering, or using a torch near pressurized fluid lines or other flammable materials. Pressurized lines can be accidentally cut when heat goes beyond the immediate flame area.



USE SAFE SERVICE PROCEDURES

Wear Protective Clothing

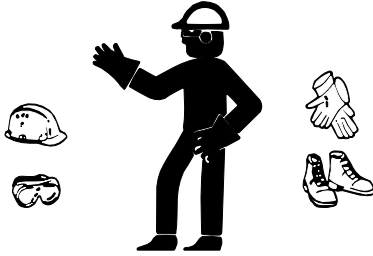

Wear close fitting clothing and safety equipment appropriate to the job.

Prolonged exposure to loud noise can cause impairment or loss of hearing. Wear a suitable hearing protective device such as earmuffs or earplugs to protect against objectionable or uncomfortable loud noises.

Operating equipment safely requires the full attention of the operator. Do not wear radio or music headphones while operating machine.

Service Machines Safely

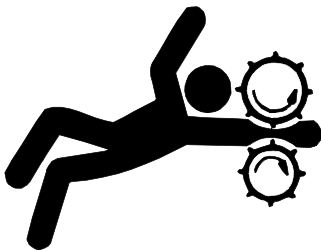

Tie long hair behind your head. Do not wear a necktie, scarf, loose clothing, or necklace when you work near machine tools or moving parts. If these items were to get caught, severe injury could result.

Remove rings and other jewelry to prevent electrical shorts and entanglement in moving parts.

Use Proper Tools

Use tools appropriate to the work. Makeshift tools and procedures can create safety hazards. Use power tools only to loosen threaded parts and fasteners. For loosening and tightening hardware, use the correct size tools. **DO NOT** use U.S. measurement tools on metric fasteners. Avoid bodily injury caused by slipping wrenches. Use only service parts meeting John Deere specifications.

Park Machine Safely

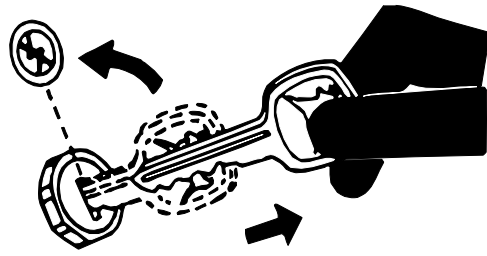

Before working on the machine:

1. Lower all equipment to the ground.
2. Stop the engine and remove the key.
3. Disconnect the battery ground strap.
4. Hang a "DO NOT OPERATE" tag in operator station.

Support Machine Properly and Use Proper Lifting Equipment

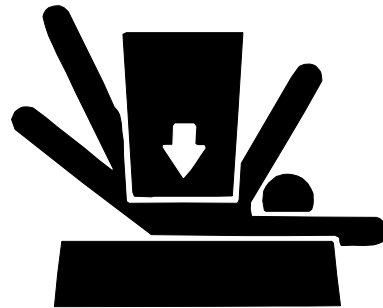

If you must work on a lifted machine or attachment, securely support the machine or attachment.

Do not support the machine on cinder blocks, hollow tiles, or props that may crumble under continuous load. Do not work under a machine that is supported solely by a jack. Follow recommended procedures in this manual.

Lifting heavy components incorrectly can cause severe injury or machine damage. Follow recommended procedure for removal and installation of components in the manual.

Work in Clean Area

Before starting a job:

1. Clean work area and machine.
2. Make sure you have all necessary tools to do your job.
3. Have the right parts on hand.
4. Read all instructions thoroughly; do not attempt shortcuts.

Using High—Pressure Washers

Directing pressurized water at electronic/electrical components or connectors, bearings, hydraulic seals, fuel injection pumps or other sensitive parts and components may cause product malfunctions. Reduce pressure and spray at a 45 to 90 degree angle.

Illuminate Work Area Safely

Illuminate your work area adequately but safely. Use a portable safety light for working inside or under the machine. Make sure the bulb is enclosed by a wire cage. The hot filament of an accidentally broken bulb can ignite spilled fuel or oil.

Work in Ventilated Area

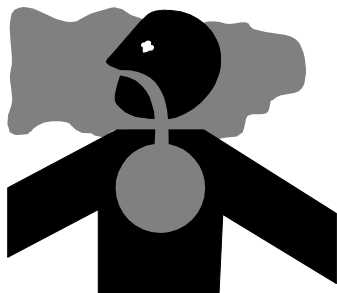

Engine exhaust fumes can cause sickness or death. If it is necessary to run an engine in an enclosed area, remove the exhaust fumes from the area with an exhaust pipe extension.

If you do not have an exhaust pipe extension, open the doors and get outside air into the area.

WARNING: California Proposition 65 Warning

Diesel engine exhaust and some of its constituents are known to the State of California to cause cancer, birth defects, and other reproductive harm.

Gasoline engine exhaust from this product contains chemicals known to the State of California to cause cancer, birth defects, or other reproductive harm.

Remove Paint Before Welding or Heating

Avoid potentially toxic fumes and dust. Hazardous fumes can be generated when paint is heated by welding, soldering, or using a torch. Do all work outside or in a well ventilated area. Dispose of paint and solvent properly. Remove paint before welding or heating. If you sand or grind paint, avoid breathing the dust. Wear an approved respirator. If you use solvent or paint stripper, remove stripper with soap and water before welding. Remove solvent or paint stripper containers and other flammable material from area. Allow fumes to disperse at least 15 minutes before welding or heating.

Avoid Harmful Asbestos Dust

Avoid breathing dust that may be generated when handling components containing asbestos fibers. Inhaled asbestos fibers may cause lung cancer.

Components in products that may contain asbestos fibers are brake pads, brake band and lining assemblies, clutch plates, and some gaskets. The asbestos used in these components is usually found in a resin or sealed in some way. Normal handling is not hazardous as long as airborne dust containing asbestos is not generated.

Avoid creating dust. Never use compressed air for cleaning. Avoid brushing or grinding material containing asbestos. When servicing, wear an approved respirator. A special vacuum cleaner is recommended to clean asbestos. If not available, apply a mist of oil or water on the material containing asbestos. Keep bystanders away from the area.



SERVICE TIRES SAFELY



Explosive separation of a tire and rim parts can cause serious injury or death.

Do not attempt to mount a tire unless you have the proper equipment and experience to perform the job. Always maintain the correct tire pressure. Do not inflate the tires above the recommended pressure. Never weld or heat a wheel and tire assembly. The heat can cause an increase in air pressure resulting in a tire explosion. Welding can structurally weaken or deform the wheel.

When inflating tires, use a clip-on chuck and extension hose long enough to allow you to stand to one side and NOT in front of or over the tire assembly. Use a safety cage if available.

Check wheels for low pressure, cuts, bubbles, damaged rims or missing lug bolts and nuts.



AVOID INJURY FROM ROTATING BLADES, AUGERS AND PTO SHAFTS

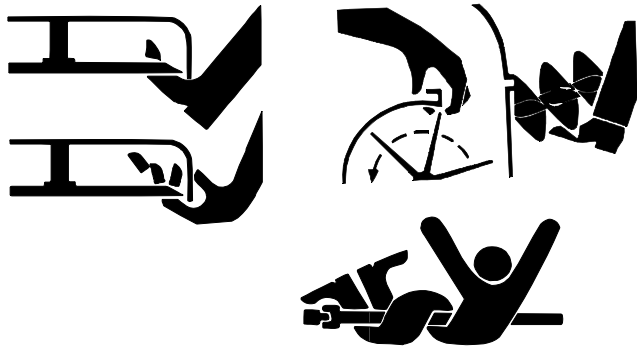

Keep hands and feet away while machine is running. Shut off power to service, lubricate, or remove mower blades, augers, or PTO shafts.

SERVICE COOLING SYSTEM SAFELY



Explosive release of fluids from pressurized cooling system can cause serious burns.

Shut off machine. Remove filler cap only when cool enough to touch with bare hands. Slowly loosen cap to first stop to relieve pressure before removing completely.

HANDLE CHEMICAL PRODUCTS SAFELY

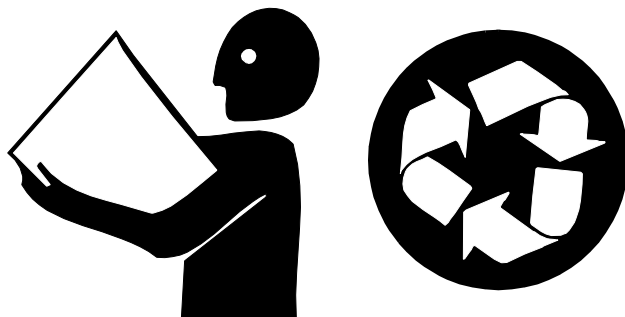

Direct exposure to hazardous chemicals can cause serious injury. Potentially hazardous chemicals used with John Deere equipment include such items as lubricants, coolants, paints, and adhesives.

A Material Safety Data Sheet (MSDS) provides specific details on chemical products: physical and health hazards, safety procedures, and emergency response techniques. Check the MSDS before you start any job using a hazardous chemical. That way you will know exactly what the risks are and how to do the job safely. Then follow procedures and recommended equipment.

Dispose of Waste Properly

Improperly disposing of waste can threaten the environment and ecology. Potentially harmful waste used with John Deere equipment includes such items as oil, fuel, coolant, brake fluid, filters, and batteries. Use leakproof containers when draining fluids. Do not use food or beverage containers that may mislead someone into drinking from them. Do not pour waste onto the ground, down a drain, or into any water source. Inquire on the proper way to recycle or dispose of waste from your local environmental or recycling center, or from your John Deere dealer.

LIVE WITH SAFETY



Before returning machine to customer, make sure machine is functioning properly, especially the safety systems. Install all guards and shields.

CONTENTS

Page



SPECIFICATIONS AND INFORMATION

SPECIFICATIONS—GX70/GX75 AND SRX75	
GENERAL SPECIFICATIONS.....	2
SPECIFICATIONS—GX95 AND SRX75/SRX95	
GENERAL SPECIFICATIONS.....	3
SPECIFICATIONS—GX85/SX85	
GENERAL SPECIFICATIONS.....	4
METRIC FASTENER TORQUE VALUES	5
METRIC FASTENER TORQUE VALUE—GRADE 7	6
INCH FASTENER TORQUE VALUES	7
O-RING SEAL SERVICE RECOMMENDATIONS	
FACE SEAL FITTINGS WITH INCH STUD ENDS TORQUE	8
FACE SEAL FITTINGS WITH METRIC STUD ENDS TORQUE.....	9
O-RING FACE SEAL FITTINGS	10
O-RING BOSS FITTINGS	10
GASOLINE SPECIFICATIONS	
4-CYCLE ENGINES—NORTH AMERICA	11
GASOLINE STORAGE	11
4-CYCLE ENGINES—EUROPE.....	12
GASOLINE STORAGE	12
OIL AND LUBRICANT SPECIFICATIONS	
4-CYCLE GASOLINE ENGINE OIL—NORTH AMERICA (KAWASAKI ENGINES) .	13
4-CYCLE GASOLINE ENGINE OIL—EUROPE (KAWASAKI ENGINES)	13
4-CYCLE GASOLINE ENGINE OIL—NORTH AMERICA (BRIGGS & STRATTON ENGINES).....	14
4-CYCLE GASOLINE ENGINE OIL—EUROPE (BRIGGS & STRATTON ENGINES).....	14
BREAK-IN 4-CYCLE GASOLINE ENGINE OIL—NORTH AMERICA	15
BREAK-IN 4-CYCLE GASOLINE ENGINE OIL—EUROPE	16
GEAR TRANSMISSION GREASE—NORTH AMERICA	17
GEAR TRANSMISSION GREASE—EUROPE	17
ANTI-CORROSION GREASE	18
GREASE—NORTH AMERICA	18
GREASE —EUROPE	19
ALTERNATIVE LUBRICANTS	19
SYNTHETIC LUBRICANTS.....	19
LUBRICANT STORAGE	19
MIXING OF LUBRICANTS	19
OIL FILTERS	20

SPECIFICATIONS—GX70/GX75 AND SRX75

GENERAL SPECIFICATIONS



Engine:

Make John Deere “K” Series
 Model FC290V
 Starting System:
 GX70..... Recoil
 GX75 and SRX75..... Electric
 Crankcase Capacity 1.1 L (1.16 U.S. qt)

Electrical System:

Type GX70 N/A
 Type GX75 12 Volt
 Battery Size GX70..... N/A
 Battery Size GX75 and SRX75 160 Cold Cranking Amps at -18°C (0°F)
 Alternator..... 3 Amp

Fuel System:

Type Carburetor
 Fuel Delivery Gravity Fed
 Capacity 4.0 L (1.1 U.S. gal)

Drive Train:

Type Gear Transaxle
 Number of Speeds 5
 Travel Speeds at Full Engine RPM:
 Forward..... 0—8.7 km/h (0—5.4 mph)
 1st Gear 1.8 km/h (1.1 mph)
 2nd Gear..... 3.5 km/h (2.2 mph)
 3rd Gear 5.3 km/h (3.3 mph)
 4th Gear 6.8 km/h (4.2 mph)
 5th Gear 8.0 km/h (5.0 mph)
 Reverse 3.1 km/h (1.9 mph)
 Final Drive..... Spur Gear
 Brakes..... Disk
 Steering..... Sector and Pinion

Tires:

Front 11 x 4.00—5
 Rear 16 x 6.50—8

Overall Dimensions:

Wheelbase 1060 mm (42 in.)
 Minimum Ground Clearance 95 mm (3.74 in.)
 Overall Length..... 1570 mm (62 in.)
 Overall Width:
 W/O Deck (Front) 694 mm (27.3 in.)
 W/O Deck (Rear) 780 mm (30.7 in.)
 W/Deck..... 790 mm (31.1 in.)
 Height 1010 mm (39.76 in.)
 Weight GX70 143 kg (315 lb)
 Weight GX75 155 kg (340 lb)

SPECIFICATIONS—GX95 AND SRX75/SRX95

GENERAL SPECIFICATIONS



Engine:

Make John Deere "K" Series
 Model SRX75 FC290V
 Models GX95 and SRX95 FB460V
 Starting System Electric
 Crankcase Capacity:
 SRX75 1.1 L (1.16 U.S. qt)
 GX95 and SRX95 1.4 L (1.48 U.S. qt)

Electrical System:

Type 12 Volt
 Battery Size 160 Cold Cranking Amps at -18°C (0°F)
 Alternator 3 Amp

Fuel System:

Type Carburetor
 Fuel Delivery:
 SRX75 Gravity Fed
 SRX95 Fuel Pump
 Fuel Tank Capacity
 SRX75 3.5 L (0.91 U.S. gal)
 GX95 and SRX95 6.5 L (1.6 U.S. gal)

Drive Train:

Type Gear Transaxle
 Number of Speeds Variable
 Travel Speeds at Full Engine RPM:
 Forward 0—8 km/h (0—5 mph)
 Reverse 3.5 km/h (2.2 mph)
 Brakes Disk
 Steering Sector and Pinion

Tires:

Front 11 x 4.00—5
 Rear 16 x 6.50—8

Overall Dimensions:

Wheelbase 1060 mm (42 in.)
 Minimum Ground Clearance 95 mm (3.74 in.)
 Overall Length 1570 mm (62 in.)
 Overall Width:
 W/O Deck (Front) 694 mm (27.3 in.)
 W/O Deck (Rear) 780 mm (30.7 in.)
 W/Deck SRX75 790 mm (31.1 in.)
 W/Deck GX95 and SRX95 1040 mm (40.9 in.)
 Height 1010 mm (39.76 in.)
 Weight:
 SRX75 167 kg (367 lbs)
 GX95 and SRX95 196 kg (431 lbs)

SPECIFICATIONS—GX85/SX85

GENERAL SPECIFICATIONS



Engine:

Make Briggs & Stratton "Diamond I/C"
 Model 28M707
 Starting System Electric
 Crankcase Capacity 1.4 L (1.48 U.S. qt)

Electrical System:

Type 12 Volt
 Battery Size 160 Cold Cranking Amps at -18°C (0°F)
 Alternator 3 Amp

Fuel System:

Type Carburetor
 Fuel Delivery Fuel Pump
 Fuel Tank Capacity:
 GX85 4 L (1.1 U.S. gal)
 SX85 3.5 L (0.91 U.S. gal)

Drive Train:

Type Gear Transaxle
 Number of Speeds GX85 5
 Number of Speeds SX85 Variable
 Travel Speeds at Full Engine RPM:
 Forward 0—8 km/h (0—5 mph)
 1st Gear 1.8 km/h (1.1 mph)
 2nd Gear 3.5 km/h (2.2 mph)
 3rd Gear 5.3 km/h (3.3 mph)
 4th Gear 6.8 km/h (4.2 mph)
 5th Gear 8.0 km/h (5.0 mph)
 Reverse 3.1 km/h (1.9 mph)
 Final Drive Spur Gear
 Brakes Disk
 Steering Sector & Pinion

Tires:

Front 11 x 4.00—5
 Rear 16 x 6.50—8

Overall Dimensions:

Wheelbase 1060 mm (42 in.)
 Minimum Ground Clearance 95 mm (3.74 in.)
 Overall Length 1570 mm (62 in.)
 Overall Width:
 W/O Deck (Front) 694 mm (27.3 in.)
 W/O Deck (Rear) 780 mm (30.7 in.)
 W/Deck 790 mm (31.1 in.)
 Height 1010 mm (39.76 in.)
 Weight:
 GX85 155 kg (340 lb)
 SX85 168 kg (370 lb)

METRIC FASTENER TORQUE VALUES

Property Class and Head Markings	4.8		8.8		9.8		10.9		12.9	
Property Class and Nut Markings	5		10		10		10		12	

TS1163



SIZE	Class 4.8		Class 8.8 or 9.8				Class 10.9				Class 12.9					
	Lubricated ^a		Dry ^a		Lubricated ^a		Dry ^a		Lubricated ^a		Dry ^a		Lubricated ^a		Dry ^a	
	N•m	lb-ft	N•m	lb-ft	N•m	lb-ft	N•m	lb-ft	N•m	lb-ft	N•m	lb-ft	N•m	lb-ft	N•m	lb-ft
M6	4.8	3.5	6	4.5	9	6.5	11	8.5	13	9.5	17	12	15	11.5	19	14.5
M8	12	8.5	15	11	22	16	28	20	32	24	40	30	37	28	47	35
M10	23	17	29	21	43	32	55	40	63	47	80	60	75	55	95	70
M12	40	29	50	37	75	55	95	70	110	80	140	105	130	95	165	120
M14	63	47	80	60	120	88	150	110	175	130	225	165	205	150	260	109
M16	100	73	125	92	190	140	240	175	275	200	350	225	320	240	400	300
M18	135	100	175	125	260	195	330	250	375	275	475	350	440	325	560	410
M20	190	140	240	180	375	275	475	350	530	400	675	500	625	460	800	580
M22	260	190	330	250	510	375	650	475	725	540	925	675	850	625	1075	800
M24	330	250	425	310	650	475	825	600	925	675	1150	850	1075	800	1350	1000
M27	490	360	625	450	950	700	1200	875	1350	1000	1700	1250	1600	1150	2000	1500
M30	675	490	850	625	1300	950	1650	1200	1850	1350	2300	1700	2150	1600	2700	2000
M33	900	675	1150	850	1750	1300	2200	1650	2500	1850	3150	2350	2900	2150	3700	2750
M36	1150	850	1450	1075	2250	1650	2850	2100	3200	2350	4050	3000	3750	2750	4750	3500

DO NOT use these hand torque values if a different torque value or tightening procedure is given for a specific application. Torque values listed are for general use only and include a ±10% variance factor. Check tightness of fasteners periodically. DO NOT use air powered wrenches.

Shear bolts are designed to fail under predetermined loads. Always replace shear bolts with identical grade.

Fasteners should be replaced with the same class. Make sure fastener threads are clean and that you properly start thread engagement. This will prevent them from failing when tightening.

When bolt and nut combination fasteners are used, torque values should be applied to the **NUT** instead of the bolt head.

Tighten toothed or serrated-type lock nuts to the full torque value.

^a "Lubricated" means coated with a lubricant such as engine oil, or fasteners with phosphate and oil coatings. "Dry" means plain or zinc plated (yellow dichromate - Specification JDS117) without any lubrication.











Reference: JDS—G200.

**METRIC FASTENER TORQUE
VALUE—GRADE 7**

Size	Steel or Gray Iron Torque		Aluminum Torque	
	N•m	lb-ft	N•m	lb-ft
M6	11	8	8	6
M8	24	18	19	14
M10	52	38	41	30
M12	88	65	70	52
M14	138	102	111	82
M16	224	165	179	132

INCH FASTENER TORQUE VALUES



SAE Grade and Head Markings	1 or 2 ^b No Marks 	5  5.1  5.2 	8  8.2 
SAE Grade and Nut Markings	2 No Marks 	5  	8   TS1162

SIZE	Grade 1		Grade 2 ^b		Grade 5, 5.1 or 5.2		Grade 8 or 8.2	
	Lubricated ^a	Dry ^a	Lubricated ^a	Dry ^a	Lubricated ^a	Dry ^a	Lubricated ^a	Dry ^a
	N•m	lb-ft	N•m	lb-ft	N•m	lb-ft	N•m	lb-ft
1/4	3.7	2.8	4.7	3.5	6	4.5	7.5	5.5
5/16	7.7	5.5	10	7	12	9	15	11
3/8	14	10	17	13	22	16	27	20
7/16	22	16	28	20	35	26	44	32
1/2	33	25	42	31	53	39	67	50
9/16	48	36	60	45	75	56	95	70
5/8	67	50	85	62	105	78	135	100
3/4	120	87	150	110	190	140	240	175
7/8	190	140	240	175	190	140	240	175
1	290	210	360	270	290	210	360	270
1-1/8	470	300	510	375	470	300	510	375
1-1/4	570	425	725	530	570	425	725	530
1-3/8	750	550	950	700	750	550	950	700
1-1/2	1000	725	1250	925	990	725	1250	930

DO NOT use these hand torque values if a different torque value or tightening procedure is given for a specific application. Torque values listed are for general use only and include a ±10% variance factor. Check tightness of fasteners periodically. DO NOT use air powered wrenches.

Shear bolts are designed to fail under predetermined loads. Always replace shear bolts with identical grade.

Fasteners should be replaced with the same grade. Make sure fastener threads are clean and that you properly start thread engagement. This will prevent them from failing when tightening.

When bolt and nut combination fasteners are used, torque values should be applied to the **NUT** instead of the bolt head.

Tighten toothed or serrated-type lock nuts to the full torque value.

^a "Lubricated" means coated with a lubricant such as engine oil, or fasteners with phosphate and oil coatings. "Dry" means plain or zinc plated (yellow dichromate - Specification JDS117) without any lubrication.

^b "Grade 2" applies for hex cap screws (not hex bolts) up to 152 mm (6-in.) long. "Grade 1" applies for hex cap screws over 152 mm (6-in.) long, and for all other types of bolts and screws of any length.

Reference: JDS—G200.

O-RING SEAL SERVICE RECOMMENDATIONS

FACE SEAL FITTINGS WITH INCH STUD ENDS TORQUE

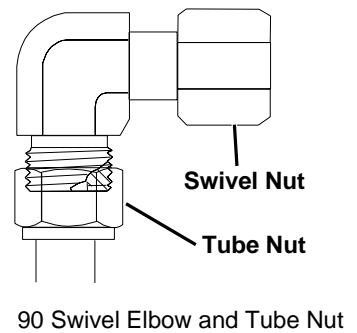
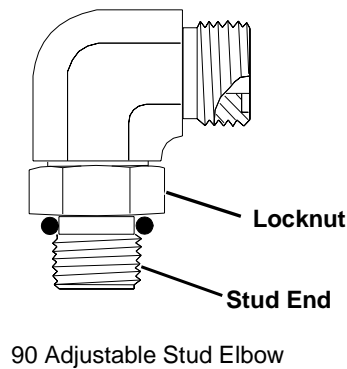
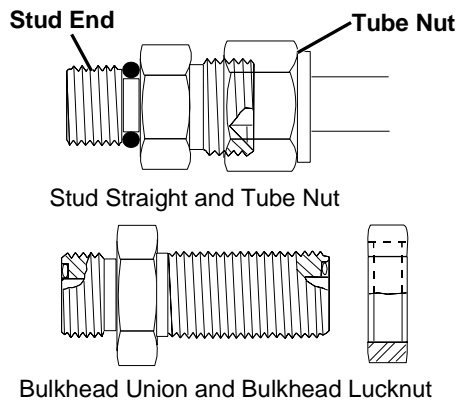

Nominal Tube O.D./Hose I.D.				Face Seal Tube/Hose End					O-ring Stud Ends		
Metric Tube O.D.	Inch Tube O.D.			Thread Size	Tube Nut/ Swivel Nut Torque		Bulkhead Locknut Torque		Thread Size	Straight Fitting or Locknut Torque	
	mm	Dash Size	in.		mm	in.	N•m	lb-ft		N•m	lb-ft
	-3	0.188	4.76						3/8-24	8	6
6	-4	0.250	6.35	9/16-18	16	12	12	9	7/16-20	12	9
8	-5	0.312	7.94						1/2-20	16	12
10	-6	0.375	9.52	11/16-16	24	18	24	18	9/16-18	24	18
12	-8	0.500	12.70	13/16-16	50	37	46	34	3/4-16	46	34
16	-10	0.625	15.88	1-14	69	51	62	46	7/8-14	62	46
	-12	0.750	19.05	1-3/16-12	102	75	102	75	1-1/16-12	102	75
22	-14	0.875	22.22	1-3/16-12	102	75	102	75	1-3/16-12	122	90
25	-16	1.000	25.40	1-7/16-12	142	105	142	105	1-5/16-12	142	105
32	-20	1.25	31.75	1-11/16-12	190	140	190	140	1-5/8-12	190	140
38	-24	1.50	38.10	2-12	217	160	217	160	1-7/8-12	217	160

NOTE: Torque tolerance is + 15 minus 20%.

FACE SEAL FITTINGS WITH METRIC STUD ENDS TORQUE

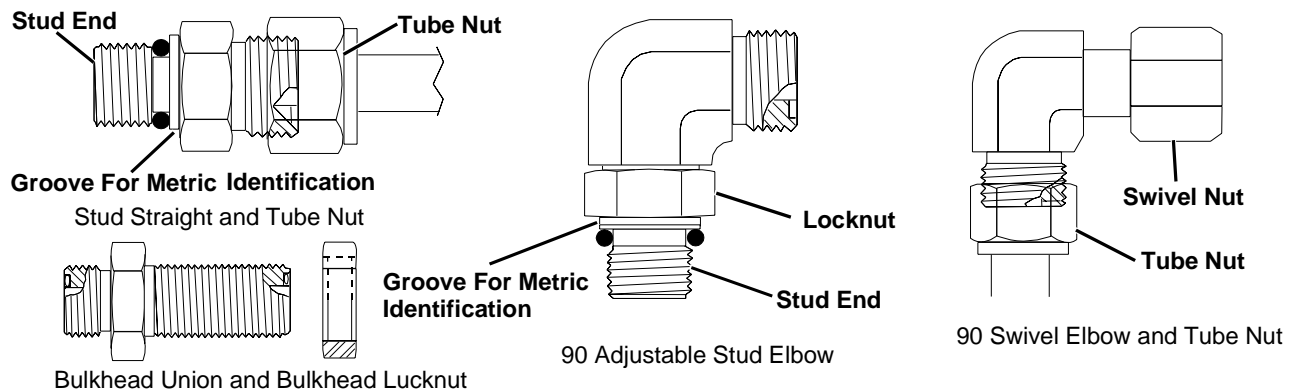

Nominal Tube O.D./Hose I.D.				Face Seal Tube/Hose End						O-ring Stud Ends, Straight Fitting or Locknut					
Metric Tube O.D.	Inch Tube O.D.			Thread Size	Hex Size	Tube Nut/ Swivel Nut Torque		Bulkhead Locknut Torque		Thread Size	Hex Size	Steel or Gray Iron Torque		Aluminum Torque	
	mm	Dash Size	in.			mm	in.	N•m	lb-ft			N•m	lb-ft	mm	mm
6	-4	0.250	6.35	9/16-18	17	16	12	12	9	M12X1.5	17	21	15.5	9	6.6
8	-5	0.312	7.94							M14X1.5	19	33	24	15	11
10	-6	0.375	9.52	11/16-16	22	24	18	24	18	M16X1.5	22	41	30	18	13
12	-8	0.500	12.70	13/16-16	24	50	37	46	34	M18X1.5	24	50	37	21	15
16	-10	0.625	15.88	1-14	30	69	51	62	46	M22X1.5	27	69	51	28	21
	-12	0.750	19.05	1-3/16-12	36	102	75	102	75	M27X2	32	102	75	46	34
22	-14	0.875	22.22	1-3/16-12	36	102	75	102	75	M30X2	36				
25	-16	1.000	25.40	1-7/16-12	41	142	105	142	105	M33X2	41	158	116	71	52
28										M38X2	46	176	130	79	58
32	-20	1.25	31.75	1-11/16-12	50	190	140	190	140	M42X2	50	190	140	85	63
38	-24	1.50	38.10	2-12	60	217	160	217	160	M48X2	55	217	160	98	72

NOTE: Torque tolerance is + 15 minus 20%.

O-RING FACE SEAL FITTINGS

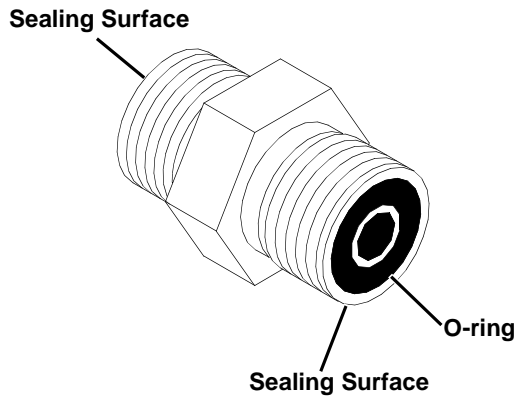

1. Inspect the fitting sealing surfaces. They must be free of dirt or defects.
2. Inspect the O-ring. It must be free of damage or defects.
3. Lubricate O-rings and install into groove using petroleum jelly to hold in place.
4. Push O-ring into the groove with plenty of petroleum jelly so O-ring is not displaced during assembly.
5. Index angle fittings and tighten by hand pressing joint together to insure O-ring remains in place.
6. Tighten fitting or nut to torque value shown on the chart per dash size stamped on the fitting. Do not allow hoses to twist when tightening fittings.

O-RING BOSS FITTINGS

1. Inspect boss O-ring boss seat. It must be free of dirt and defects. If repeated leaks occur, inspect for defects with a magnifying glass. Some raised defects can be removed with a slip stone.

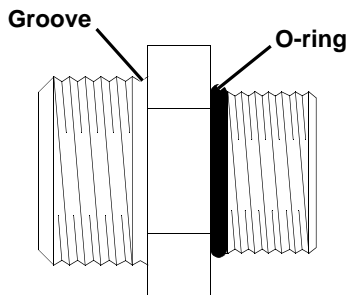

2. Put hydraulic oil or petroleum jelly on the O-ring. Place electrical tape over the threads to protect O-ring from nicks. Slide O-ring over the tape and into the groove of fitting. Remove tape.

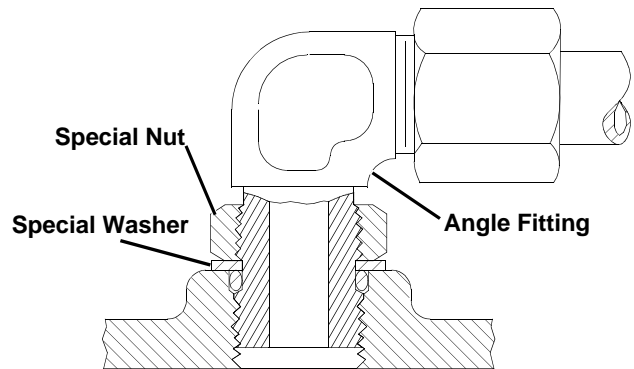

3. For angle fittings, loosen special nut and push special washer against threads so O-ring can be installed into the groove of fitting.
4. Turn fitting into the boss by hand until special washer or washer face (straight fitting) contacts boss face and O-ring is squeezed into its seat.
5. To position angle fittings, turn the fitting counter-clockwise a maximum of one turn.
6. Tighten straight fittings to torque value shown on chart. For angle fittings, tighten the special nut to value shown in the chart while holding body of fitting with a wrench.

STRAIGHT FITTING OR SPECIAL NUT TORQUE

Thread Size	Torque ^a		Number of Flats ^b
	N•m	lb-ft	
3/8-24 UNF	8	(6)	2
7/16-20 UNF	12	(9)	2
1/2-20 UNF	16	(12)	2
9/16-18 UNF	24	(18)	2
3/4-16 UNF	46	(34)	2
7/8-14 UNF	62	(46)	1-1/2
1-1/16-12 UN	102	(75)	1
1-3/16-12 UN	122	(90)	1
1-5/16-12 UN	142	(105)	3/4
1-5/8-12 UN	190	(140)	3/4
1-7/8-12 UN	217	(160)	1/2

a. Torque tolerance is ± 10 percent.
 b. To be used if a torque wrench cannot be used. After tightening fitting by hand, put a mark on nut or boss; then tighten special nut or straight fitting the number of flats shown.

GASOLINE SPECIFICATIONS

4-CYCLE ENGINES—NORTH AMERICA

CAUTION

Gasoline is **HIGHLY FLAMMABLE**, handle it with care.

DO NOT refuel machine while:

- indoors, always fill gas tank outdoors
- machine is near an open flame or sparks
- engine is running, **STOP** engine
- engine is hot, allow it to cool sufficiently first
- smoking

Help prevent fires:

- fill gas tank to bottom of filler neck only
- be sure fill cap is tight after fueling
- clean up any gas spills **IMMEDIATELY**
- keep machine clean and in good repair—free of excess grease, oil, debris, and faulty or damaged parts
- any storage of machines with gas left in tank should be in an area that is well ventilated to prevent possible igniting of fumes by an open flame or spark, this includes any appliance with a pilot light

To prevent fire or explosion caused by **STATIC ELECTRIC DISCHARGE** during fueling:

- **ONLY** use a clean, approved **POLYETHYLENE PLASTIC** fuel container and funnel **WITHOUT** any metal screen or filter

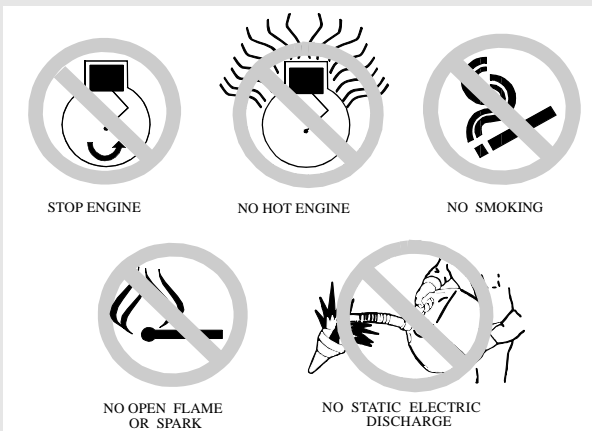

To avoid engine damage:

- DO NOT mix oil with gasoline
- **ONLY** use clean, fresh unleaded gasoline with an octane rating (anti-knock index) of 87 or higher
- fill gas tank at the end of each day's operation to help prevent condensation from forming inside a partially filled tank
- keep up with specified service intervals

Use of alternative oxygenated, gasohol blended, unleaded gasoline is acceptable as long as:

- the ethyl or grain alcohol blends DO NOT exceed 10% by volume or
- methyl tertiary butyl ether (MTBE) blends DO NOT exceed 15% by volume

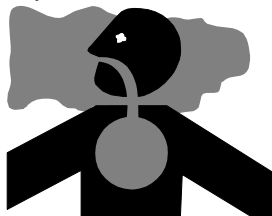

IMPORTANT: DO NOT use **METHANOL** gasolines because **METHANOL** is harmful to the environment and to your health.

WARNING

California Proposition 65 Warning: Gasoline engine exhaust from this product contains chemicals known to the State of California to cause cancer, birth defects, or other reproductive harm.

GASOLINE STORAGE

IMPORTANT: Keep all dirt, scale, water or other foreign material out of gasoline.

Keep gasoline stored in a safe, protected area. Storage of gasoline in a clean, properly marked ("**UNLEADED GASOLINE**") **POLYETHYLENE PLASTIC** container **WITHOUT** any metal screen or filter is recommended. **DO NOT** use de-icers to attempt to remove water from gasoline or depend on fuel filters to remove water from gasoline. Use a water separator installed in the storage tank outlet. **BE SURE** to properly discard unstable or contaminated gasoline. When storing unit or gasoline, it is recommended that you add **John Deere Gasoline Conditioner and Stabilizer (TY15977)** or an equivalent to the gasoline. **BE SURE** to follow directions on container and to properly discard empty container.

4-CYCLE ENGINES—EUROPE

CAUTION

Gasoline is **HIGHLY FLAMMABLE**, handle it with care.

DO NOT refuel machine while:

- indoors, always fill gas tank outdoors
- machine is near an open flame or sparks
- engine is running, **STOP** engine
- engine is hot, allow it to cool sufficiently first
- smoking

Help prevent fires:

- fill gas tank to bottom of filler neck only
- be sure fill cap is tight after fueling
- clean up any gas spills **IMMEDIATELY**
- keep machine clean and in good repair—free of excess grease, oil, debris, and faulty or damaged parts
- any storage of machines with gas left in tank should be in an area that is well ventilated to prevent possible igniting of fumes by an open flame or spark, this includes any appliance with a pilot light

To prevent fire or explosion caused by **STATIC ELECTRIC DISCHARGE** during fueling:

- **ONLY** use a clean, approved **POLYETHYLENE PLASTIC** fuel container and funnel **WITHOUT** any metal screen or filter

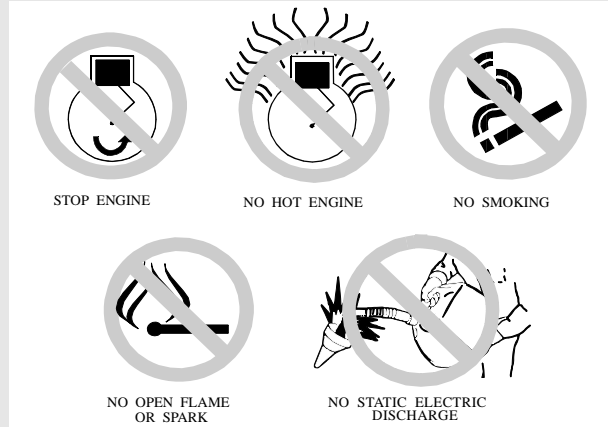

To avoid engine damage:

- **DO NOT** mix oil with gasoline
- **ONLY** use clean, fresh unleaded gasoline with an octane rating (anti-knock index) of 87 or higher
- fill gas tank at the end of each day's operation to help prevent condensation from forming inside a partially filled tank
- keep up with specified service intervals

Use of alternative oxygenated, gasohol blended, unleaded gasoline is acceptable as long as:

- the ethyl or grain alcohol blends **DO NOT** exceed 10% by volume or
- methyl tertiary butyl ether (MTBE) blends **DO NOT** exceed 15% by volume

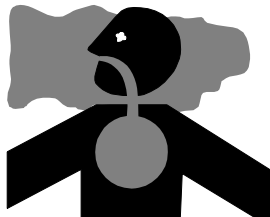

IMPORTANT: DO NOT use **METHANOL** gasolines because **METHANOL** is harmful to the environment and to your health.

GASOLINE STORAGE

IMPORTANT: Keep all dirt, scale, water or other foreign material out of gasoline.

Keep gasoline stored in a safe, protected area. Storage of gasoline in a clean, properly marked ("**UNLEADED GASOLINE**") **POLYETHYLENE PLASTIC** container **WITHOUT** any metal screen or filter is recommended. **DO NOT** use de-icers to attempt to remove water from gasoline or depend on fuel filters to remove water from gasoline. Use a water separator installed in the storage tank outlet. **BE SURE** to properly discard unstable or contaminated gasoline. When storing unit or gasoline, it is recommended that you add **John Deere Gasoline Conditioner and Stabilizer (TY15977)** or an equivalent to the gasoline. **BE SURE** to follow directions on container and to properly discard empty container.

OIL AND LUBRICANT SPECIFICATIONS

4-CYCLE GASOLINE ENGINE OIL—NORTH AMERICA (KAWASAKI ENGINES)

Use the appropriate oil viscosity based on the expected air temperature range during the period between recommended oil changes. Operating outside of these recommended oil air temperature ranges may cause premature engine failure.

The following John Deere oils are **PREFERRED**:

- **PLUS-4®—SAE 10W-40**
- **TORQ-GARD SUPREME®—SAE 5W-30**

The following John Deere oils are **also recommended**, based on their specified temperature range:

- **TURF-GARD®—SAE 10W-30**
- **PLUS-4®—SAE 10W-30**
- **TORQ-GARD SUPREME®—SAE 30**

Other oils may be used if above John Deere oils are not available, provided they meet one of the following specifications:

- SAE 10W-40—API Service Classification SG or higher
- SAE 5W-30—API Service Classification SG or higher
- SAE 10W-30—API Service Classification SG or higher
- SAE 30—API Service Classification SC or higher

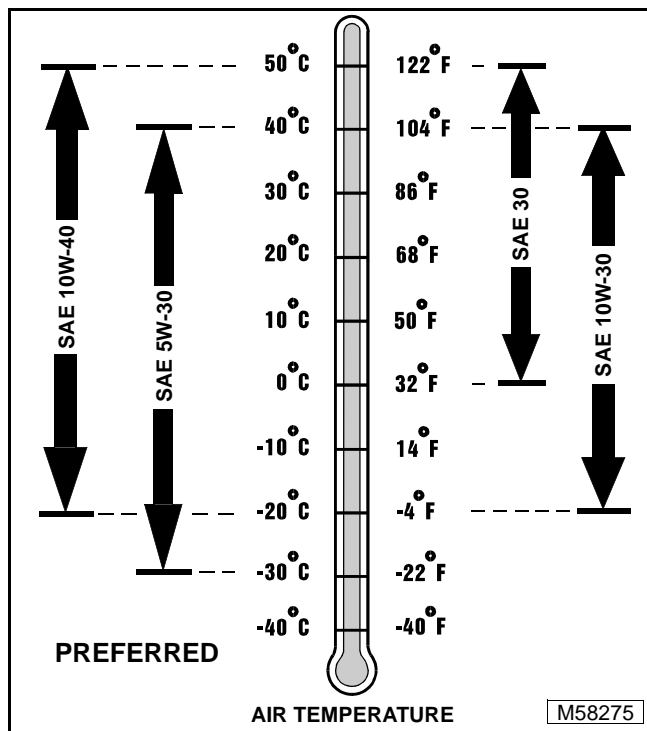

4-CYCLE GASOLINE ENGINE OIL—EUROPE (KAWASAKI ENGINES)

Use the appropriate oil viscosity based on the expected air temperature range during the period between recommended oil changes. Operating outside of these recommended oil air temperature ranges may cause premature engine failure.



The following John Deere oils are **PREFERRED**:

- **TORQ-GARD SUPREME®—SAE 10W-40**
- **UNI-GARD™—SAE 10W-40**
- **TORQ-GARD SUPREME®—SAE 5W-30**
- **UNI-GARD™—SAE 5W-30**

The following John Deere oils are **also recommended**, based on their specified temperature range:

- **TORQ-GARD SUPREME®—SAE 10W-30**
- **UNI-GARD™—SAE 10W-30**
- **TORQ-GARD SUPREME®—SAE 30**
- **UNI-GARD™—SAE 30**

Other oils may be used if above John Deere oils are not available, provided they meet one of the following specifications:

- CCMC Specification G4 or higher

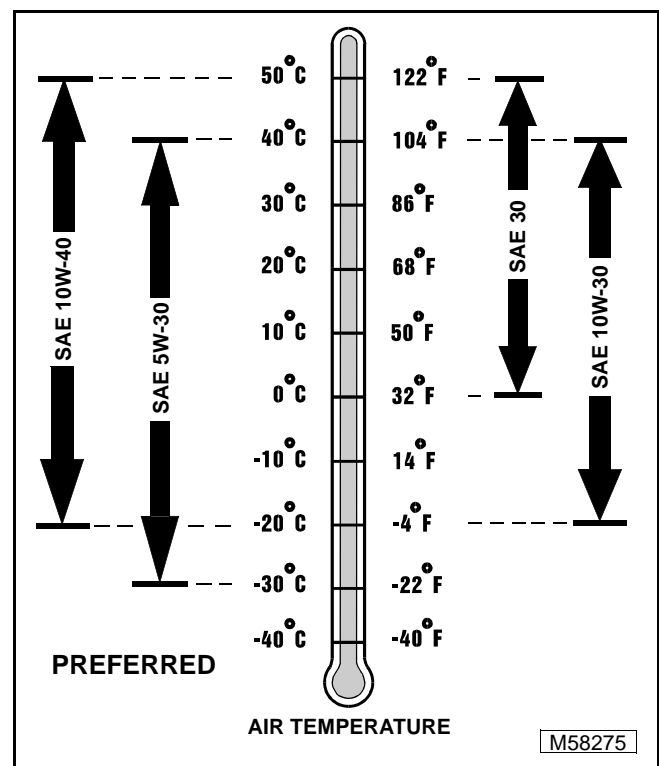

4-CYCLE GASOLINE ENGINE OIL— NORTH AMERICA (BRIGGS & STRATTON ENGINES)



Use the appropriate oil viscosity based on the expected air temperature range during the period between recommended oil changes. Operating outside of these recommended oil air temperature ranges may cause premature engine failure.

The following John Deere oils are **PREFERRED**:

- TORQ-GARD SUPREME®—SAE 30
- TORQ-GARD SUPREME®—SAE 5W-30

The following John Deere oils are **also recommended**, based on their specified temperature range

- TURF-GARD®—SAE 10W-30
- PLUS-4®—SAE 10W-30

Other oils may be used if above John Deere oils are not available, provided they meet one of the following specifications:

- SAE 30—API Service Classification SC or higher
- SAE 5W-30—API Service Classification SG or higher
- SAE 10W-30—API Service Classification SG or higher

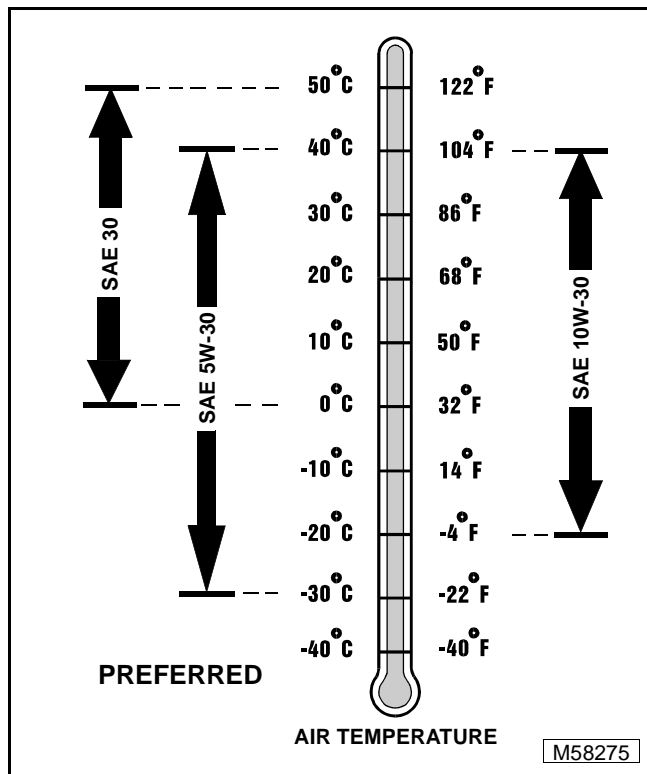

4-CYCLE GASOLINE ENGINE OIL— EUROPE (BRIGGS & STRATTON ENGINES)

Use the appropriate oil viscosity based on the expected air temperature range during the period between recommended oil changes. Operating outside of these recommended oil air temperature ranges may cause premature engine failure.

The following John Deere oils are **PREFERRED**:

- TORQ-GARD SUPREME®—SAE 30
- UNI-GARD™—SAE 30
- TORQ-GARD SUPREME®—SAE 5W-30
- UNI-GARD™—SAE 5W-30

The following John Deere oils are **also recommended**, based on their specified temperature range:

- TORQ-GARD SUPREME®—SAE 10W-30
- UNI-GARD™—SAE 10W-30

Other oils may be used if above John Deere oils are not available, provided they meet one of the following specifications:

- CCMC Specification G4 or higher

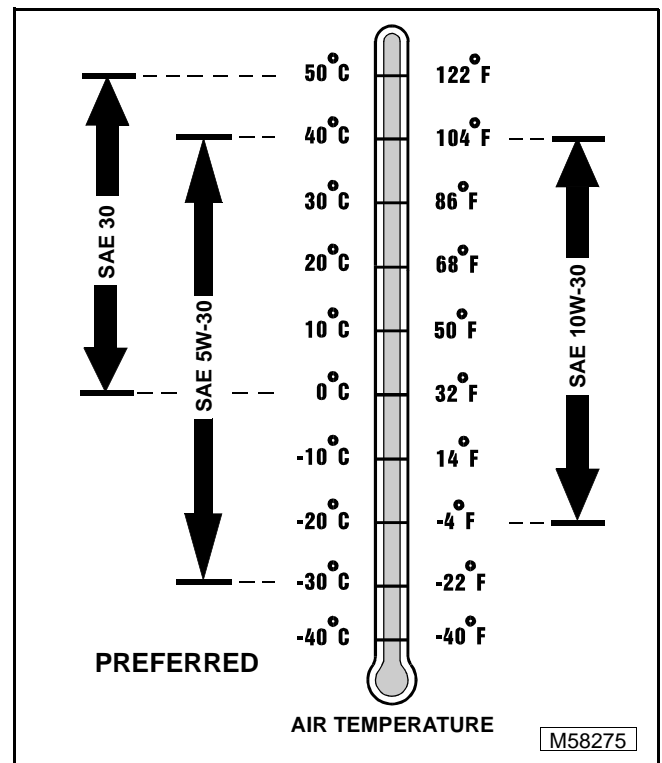

BREAK-IN 4-CYCLE GASOLINE ENGINE OIL—NORTH AMERICA

IMPORTANT: ONLY use a quality break-in oil in rebuilt or remanufactured engines for the first 5 hours (maximum) of operation. DO NOT use oils with heavier viscosity weights than SAE 5W-30 or oils meeting specifications API SG or SH, these oils will not allow rebuilt or remanufactured engines to break-in properly.

The following John Deere oil is **PREFERRED**:

- **BREAK-IN ENGINE OIL**

John Deere BREAK-IN ENGINE OIL is formulated with special additives for aluminum and cast iron type engines to allow the power cylinder components (pistons, rings, and liners as well) to “wear-in” while protecting other engine components, valve train and gears, from abnormal wear. Engine rebuild instructions should be followed closely to determine if special requirements are necessary.

John Deere BREAK-IN ENGINE OIL is also recommended for non-John Deere engines, both aluminum and cast iron types.

The following John Deere oil is **also recommended** as a break-in engine oil:

- **TORQ-GARD SUPREME®—SAE 5W-30**

If the above recommended John Deere oils are not available, use a break-in engine oil meeting the following specification during the first 5 hours (maximum) of operation:

- SAE 5W-30—API Service Classification SE or higher

IMPORTANT: After the break-in period, use the John Deere oil that is recommended for this engine.

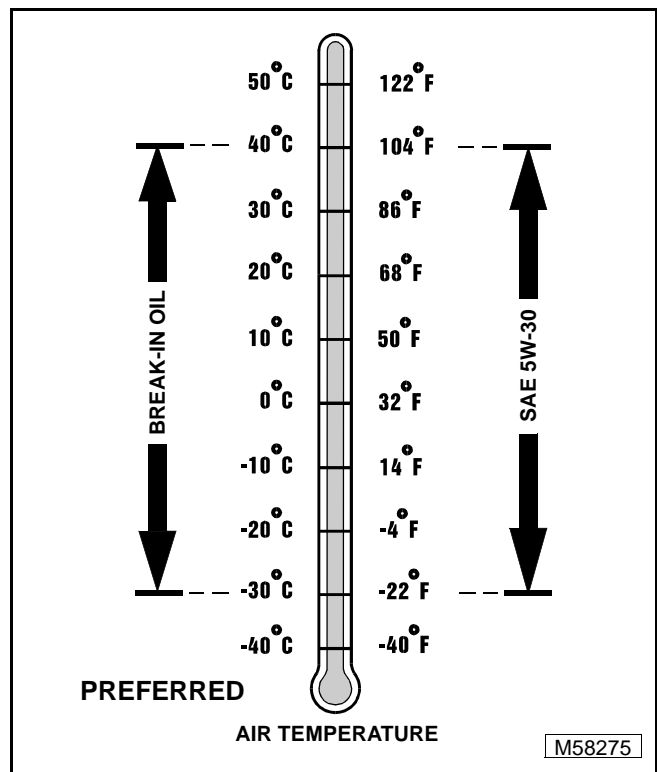

BREAK-IN 4-CYCLE GASOLINE ENGINE OIL—EUROPE



IMPORTANT: ONLY use a quality break-in oil in rebuilt or remanufactured engines for the first 5 hours (maximum) of operation. DO NOT use oils with heavier viscosity weights than SAE 5W-30 or oils meeting CCMC Specification G5—these oils will not allow rebuilt or remanufactured engines to break-in properly.

The following John Deere oil is **PREFERRED**:

- **BREAK-IN ENGINE OIL**

John Deere **BREAK-IN ENGINE OIL** is formulated with special additives for aluminum and cast iron type engines to allow the power cylinder components (pistons, rings, and liners as well) to “wear-in” while protecting other engine components, valve train and gears, from abnormal wear. Engine rebuild instructions should be followed closely to determine if special requirements are necessary.

John Deere **BREAK-IN ENGINE OIL** is also recommended for non-John Deere engines, both aluminum and cast iron types.

The following John Deere oil is **also recommended** as a break-in engine oil:

- **TORQ-GARD SUPREME®—SAE 5W-30**

If the above recommended John Deere oils are not available, use a break-in engine oil meeting the following specification during the first 5 hours (maximum) of operation:

- SAE 5W-30—CCMC Specification G4 or higher

IMPORTANT: After the break-in period, use the John Deere oil that is specified for this engine.

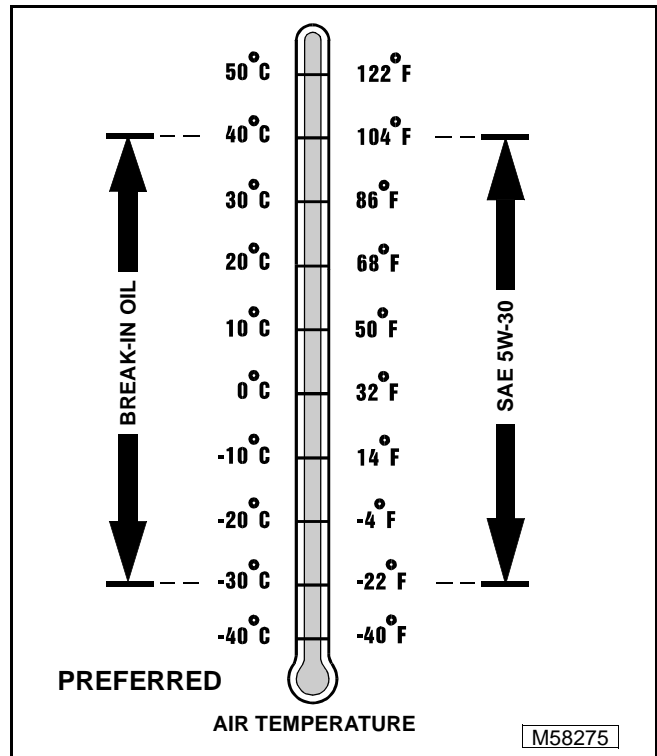

GEAR TRANSMISSION GREASE—NORTH AMERICA

Use the following gear grease based on the air temperature range. Operating outside of the recommended grease air temperature range may cause premature gear transmission failure.

IMPORTANT: ONLY use a quality gear grease in this transmission. DO NOT mix any other greases in this transmission. DO NOT use any BIO-GREASE in this transmission.

The following John Deere gear grease is **PREFERRED**:

- **NON-CLAY HIGH-TEMPERATURE EP GREASE®—JDM J13E4, NLGI Grade 2**

Other gear greases may be used if above recommended John Deere gear grease is not available, provided they meet one of the following specification:

- John Deere Standard JDM J13E4, NLGI Grade 2

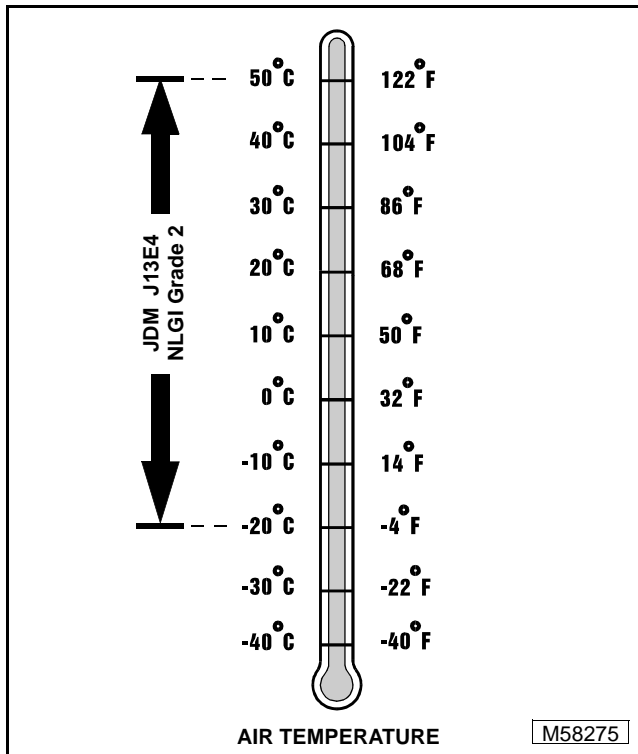

GEAR TRANSMISSION GREASE—EUROPE

Use the following gear grease based on the air temperature range. Operating outside of the recommended grease air temperature range may cause premature gear transmission failure.



IMPORTANT: ONLY use a quality gear grease in this transmission. DO NOT mix any other greases in this transmission. DO NOT use any BIO-GREASE in this transmission.

The following John Deere gear grease is **PREFERRED**:

- **GREASE-GARD™—JDM J13E4, NLGI Grade 2**

Other gear greases may be used if above recommended John Deere gear grease is not available, provided they meet the following specification:

- John Deere Standard JDM J13E4, NLGI Grade 2

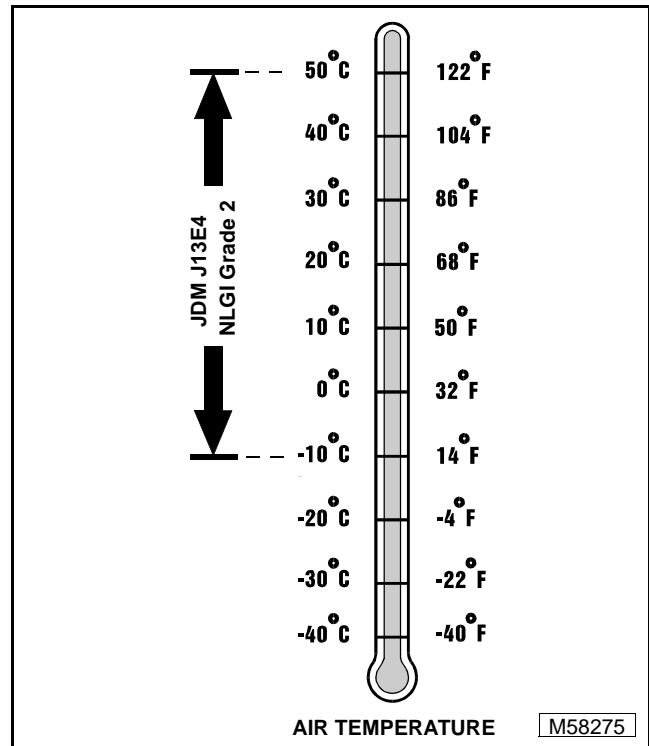

ANTI-CORROSION GREASE SPECIFICATIONS



This anti-corrosion grease is formulated to provide the best protection against absorbing moisture, which is one of the major causes of corrosion. This grease is also superior in its resistance to separation and migration.

The following anti-corrosion grease is **PREFERRED**:

- DuBois MPG-2® Multi-Purpose Polymer Grease—M79292

Other greases may be used if they meet or exceed the following specifications:

- John Deere Standard JDM J13A2, NLGI Grade 1

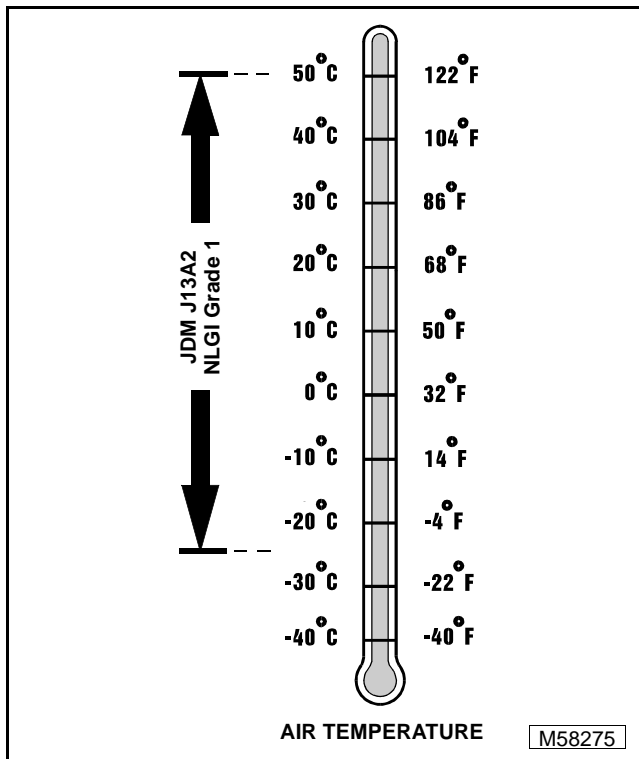

GREASE—NORTH AMERICA

Use the following grease based on the air temperature range. Operating outside of the recommended grease air temperature range may cause premature failures.

IMPORTANT: ONLY use a quality grease in this application. DO NOT mix any other greases in this application. DO NOT use any BIO-GREASE in this application.

The following John Deere grease is **PREFERRED**:

- **NON-CLAY HIGH-TEMPERATURE EP GREASE®—JDM J13E4, NLGI Grade 2**

Other greases may be used if above preferred John Deere grease is not available, provided they meet the following specification:

- John Deere Standard JDM J13E4, NLGI Grade 2

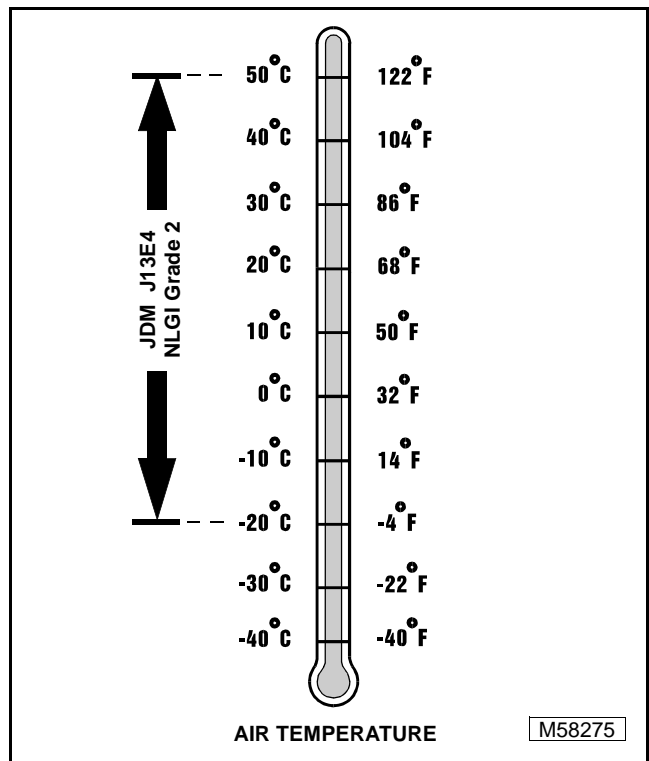

GREASE —EUROPE

Use the following grease based on the air temperature range. Operating outside of the recommended grease air temperature range may cause premature failures.

IMPORTANT: ONLY use a quality grease in this application. DO NOT mix any other greases in this application. DO NOT use any BIO-GREASE in this application.

The following John Deere grease is **PREFERRED**:

- **GREASE-GARD™—JDM J13E4, NLGI Grade 2**

Other greases may be used if above preferred John Deere grease is not available, provided they meet the following specification:

- John Deere Standard JDM J13E4, NLGI Grade 2

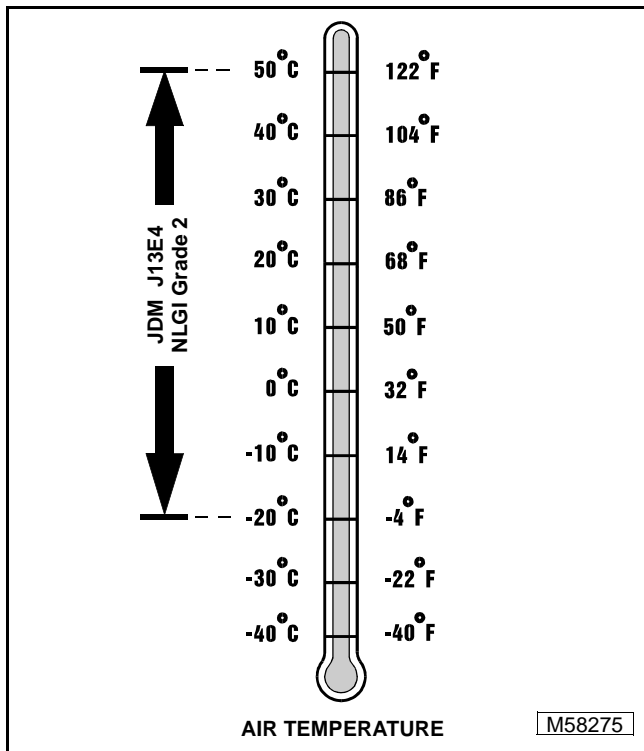

ALTERNATIVE LUBRICANTS

Conditions in certain geographical areas outside the United States and Canada may require different lubricant recommendations than the ones printed in this technical manual or the operator's manual. Consult with your John Deere Dealer, or Sales Branch, to obtain the alternative lubricant recommendations.



IMPORTANT: Use of alternative lubricants could cause reduced life of the component.

If alternative lubricants are to be used, it is recommended that the factory fill be thoroughly removed before switching to any alternative lubricant.

SYNTHETIC LUBRICANTS

Synthetic lubricants may be used in John Deere equipment if they meet the applicable performance requirements (industry classification and/or military specification) as shown in this manual.

The recommended air temperature limits and service or lubricant change intervals should be maintained as shown in the operator's manual.

Avoid mixing different brands, grades, or types of oil. Oil manufacturers blend additives in their oils to meet certain specifications and performance requirements. Mixing different oils can interfere with the proper functioning of these additives and degrade lubricant performance.

LUBRICANT STORAGE

All machines operate at top efficiency only when clean lubricants are used. Use clean storage containers to handle all lubricants. Store them in an area protected from dust, moisture, and other contamination. Store drums on their sides. Make sure all containers are properly marked as to their contents. Dispose of all old, used containers and their contents properly.

MIXING OF LUBRICANTS

In general, avoid mixing different brands or types of lubricants. Manufacturers blend additives in their lubricants to meet certain specifications and performance requirements. Mixing different lubricants can interfere with the proper functioning of these additives and lubricant properties which will downgrade their intended specified performance.

OIL FILTERS



IMPORTANT: Filtration of oils is critical to proper lubrication performance. Always change filters regularly.

The following John Deere oil filters are PREFERRED:

- AUTOMOTIVE AND LIGHT TRUCK ENGINE OIL FILTERS

Most John Deere filters contain pressure relief and anti-drainback valves for better engine protection.

Other oil filters may be used if above recommended John Deere oil filters are not available, provided they meet the following specification:

- ASTB Tested In Accordance With SAE J806

NOTES

CONTENTS

Page

ENGINE

SPECIFICATIONS—FC290V	
ENGINE APPLICATIONS	7
TEST AND ADJUSTMENT SPECIFICATIONS	7
REPAIR SPECIFICATIONS	7
SPECIFICATIONS—FB460V	
ENGINE APPLICATIONS	10
TEST AND ADJUSTMENT SPECIFICATIONS	10
REPAIR SPECIFICATIONS	10
SPECIFICATIONS—BRIGGS & STRATTON	
ENGINE APPLICATIONS	13
TEST AND ADJUSTMENT SPECIFICATIONS	13
REPAIR SPECIFICATIONS	13
ENGINE COMPONENT LOCATION—“K” SERIES FC290V	15
ENGINE COMPONENT LOCATION—“K” SERIES FB460V	16
THEORY OF OPERATION—“K” SERIES FC290V	
GOVERNOR OPERATION	17
COMPRESSION RELEASE OPERATION	18
LUBRICATION SYSTEM OPERATION	19
CRANKCASE OPERATION	20
FUEL/AIR SUPPLY SYSTEM OPERATION	21
THEORY OF OPERATION—“K” SERIES FB460V	
GOVERNOR OPERATION	22
LUBRICATION SYSTEM OPERATION	23
FUEL/AIR SUPPLY SYSTEM OPERATION	24
TROUBLESHOOTING	25
ENGINE SYSTEM DIAGNOSIS—“K” SERIES FC290V	
WILL NOT START OR STARTS HARD	28
WILL NOT STAY RUNNING OR RUNS ROUGH	30
ENGINE PULLS OVER HARD OR RECOIL SNAPS BACK	32
BLACK SMOKE AT START OR DURING OPERATION	34
BLUE SMOKE AT START OR DURING OPERATION	36
EXCESSIVE OIL CONSUMPTION	38
ENGINE SURGES	40
UNEVEN OR UNCONTROLLED RPM	42
LOW POWER	44





	Page
ENGINE SYSTEM DIAGNOSIS—"K" SERIES FB460V	
WILL NOT START OR STARTS HARD	46
WILL NOT STAY RUNNING OR RUNS ROUGH	48
ENGINE SPINS OVER HARD	50
BLACK SMOKE AT START OR DURING OPERATION	52
BLUE SMOKE AT START OR DURING OPERATION	54
EXCESSIVE OIL CONSUMPTION	56
ENGINE SURGES	58
BACKFIRES AT SHUTDOWN	60
UNEVEN OR UNCONTROLLED RPM.	62
LOW POWER	64
ENGINE SYSTEM DIAGNOSIS—BRIGGS & STRATTON	
ENGINE WILL NOT START AND HARD TO START, KICKBACK	66
LACK OF POWER	68
EXCESSIVE OIL CONSUMPTION	70
TESTS AND ADJUSTMENTS—"K" SERIES FC290V (GX70/GX75/SRX75)	
COMPRESSION AND CYLINDER LEAKAGE TEST	72
CRANKCASE VACUUM TEST	72
CARBURETOR SLOW IDLE TEST AND ADJUSTMENT	73
GOVERNOR AND FAST IDLE TEST AND ADJUSTMENT	73
THROTTLE CABLE AND CHOKE ADJUSTMENT	74
VALVE CLEARANCE TEST AND ADJUSTMENT	74
COMPRESSION RELEASE OPERATION TEST	75
TESTS AND ADJUSTMENTS—"K" SERIES FB460V (GX95/SRX95)	
COMPRESSION AND CYLINDER LEAKAGE TEST	76
CRANKCASE VACUUM TEST	76
CARBURETOR SLOW IDLE TEST AND ADJUSTMENT	77
GOVERNOR AND FAST IDLE TEST AND ADJUSTMENT	77
THROTTLE CABLE AND CHOKE ADJUSTMENT	78
VALVE CLEARANCE TEST AND ADJUSTMENT	78
FUEL PUMP PRESSURE AND FLOW TESTS	79
OIL PUMP PRESSURE TEST	79
TESTS AND ADJUSTMENTS—BRIGGS & STRATTON (GX85/SX85)	
CARBURETOR ADJUSTMENTS	81
COMPRESSION TEST	81
FUEL PUMP PRESSURE AND FLOW TESTS	82

	Page
FUEL AND AIR REPAIR—GX70/GX75/SRX75	
CARBURETOR—REMOVAL/INSTALLATION	83
FUEL FILTER—REPLACEMENT	83
FUEL SHUT-OFF VALVE—REPLACEMENT	84
FUEL TANK AND LINES—REMOVAL/INSPECTION/INSTALLATION	84
THROTTLE CONTROL LEVER AND CABLE—REPLACEMENT	84
AIR CLEANER ASSEMBLY—REMOVAL/INSTALLATION/INSPECTION	85
BREATHING ASSEMBLY—REMOVAL/INSTALLATION	85
FUEL AND AIR REPAIR—GX85/SX85	
AIR CLEANER ASSEMBLY—REMOVAL/INSPECTION/INSTALLATION	86
THROTTLE CONTROL LEVER AND CABLE ASSEMBLY FOR GX85 (S. N. M0GX85X0850001–096966) AND SX85 (S. N. M0SX85X085001–095909)— REMOVAL/INSTALLATION	86
THROTTLE CONTROL LEVER AND CABLE ASSEMBLY FOR GX85 (S. N. M0GX85X0096966–) AND SX85 (S. N. M0SX85X095909–)— REMOVAL/INSTALLATION	89
CARBURETOR—REMOVAL/INSTALLATION	93
FUEL PUMP—REMOVAL/INSTALLATION	93
FUEL PUMP—DISASSEMBLY/INSPECTION/ASSEMBLY	93
FUEL FILTER—REPLACEMENT	94
BREATHING ASSEMBLY—REMOVAL/INSTALLATION	95
FUEL AND AIR REPAIR—GX95/SRX95	
FUEL TANK—REMOVAL/INSPECTION/INSTALLATION	96
FUEL HOSES—REPLACEMENT	96
AIR CLEANER ASSEMBLY—REMOVAL/INSPECTION/INSTALLATION	96
CARBURETOR—REMOVAL/INSTALLATION	97
FUEL PUMP—REMOVAL/INSTALLATION	97
FUEL PUMP—DISASSEMBLY/INSPECTION/ASSEMBLY	98
FUEL FILTER—REPLACEMENT	98
THROTTLE CONTROL LEVER AND CABLE—REPLACEMENT	99
FUEL TANK AND LINES (GX95)—REMOVAL/INSPECTION/INSTALLATION	99
THROTTLE CONTROL LEVER AND CABLE (GX95)—REPLACEMENT	99
BREATHING—REMOVAL/INSPECTION/INSTALLATION	100
CARBURETOR—DISASSEMBLY/CLEANING/INSPECTION/ASSEMBLY	102





	Page
CARBURETOR REPAIR	
FC290V CARBURETOR	103
FB460V CARBURETOR (WITHOUT FUEL SHUT-OFF SOLENOID)	104
FB460V CARBURETOR (WITH FUEL SHUTOFF SOLENOID)	105
CARBURETOR (BRIGGS & STRATTON)—DISASSEMBLY	106
CARBURETOR—CLEANING/INSPECTION	107
CARBURETOR (BRIGGS & STRATTON)—ASSEMBLY	108
FC290V (GX70/GX75/SRX75)	
ENGINE—REMOVAL/INSTALLATION	110
MUFFLER AND SHIELD—REMOVAL/INSTALLATION	111
BLOWER HOUSING (RECOIL STARTER)—REMOVAL/INSTALLATION	112
BLOWER HOUSING (ELECTRIC STARTER)—REMOVAL/INSTALLATION	112
FLYWHEEL—REMOVAL/INSTALLATION	113
ROCKER ARM ASSEMBLY—REMOVAL/INSTALLATION	113
ROCKER ARM ASSEMBLY—INSPECTION	113
CYLINDER HEAD—REMOVAL/INSTALLATION	114
VALVES AND SPRINGS—REMOVAL/INSTALLATION	114
STEM SEALS AND SPRINGS—INSPECTION/REPLACEMENT	115
CYLINDER HEAD—INSPECTION	115
VALVE GUIDES—INSPECTION	115
VALVE GUIDE BUSHINGS—REPLACEMENT	116
VALVE SEATS—RECONDITIONING	116
CHECK VALVE CLEARANCE	116
CRANKCASE COVER—REMOVAL/INSTALLATION	117
CRANKCASE COVER—OIL SEAL REPLACEMENT	117
CAMSHAFT—REMOVAL/INSTALLATION	118
CAMSHAFT—INSPECTION	118
CAMSHAFT PLAIN BEARINGS—INSPECTION	118
AUTOMATIC COMPRESSION RELEASE (A.C.R.)—INSPECTION	119
TAPPETS—REMOVAL/INSPECTION/INSTALLATION	119
CAMSHAFT AXIAL PLAY—ADJUSTMENT	119
PISTON AND CONNECTING ROD—REMOVAL/INSTALLATION	120
PISTON AND CONNECTING ROD—DISASSEMBLY/INSPECTION/ASSEMBLY	120
PISTON—INSPECTION	121
CONNECTING ROD—INSPECTION	122
PISTON RINGS—REMOVAL/INSTALLATION	122
CHECK PISTON RING END GAP	122
RECIPROCATING BALANCER—REMOVAL/INSTALLATION	123
RECIPROCATING BALANCER—DISASSEMBLY/ASSEMBLY	123
BALANCER ASSEMBLY—INSPECTION	124
BALANCER BUSHINGS—REPLACEMENT	124
CRANKSHAFT—REMOVAL/INSPECTION/INSTALLATION	124
CRANKSHAFT PLAIN BEARING—INSPECTION	125
CRANKSHAFT BALL BEARING—INSPECTION	125
CRANKSHAFT—ALIGNMENT	126

	Page
CRANKSHAFT END PLAY—MEASUREMENT	126
CRANKSHAFT END PLAY—ADJUSTMENT	126
CYLINDER BLOCK—INSPECTION	127
REBORE CYLINDER BLOCK	127
OIL SLINGER—INSPECTION/REPLACEMENT	128
OIL FILTER MANIFOLD—REMOVAL/INSPECTION/INSTALLATION	128
GOVERNOR ASSEMBLY—REMOVAL/INSTALLATION	128
GOVERNOR SHAFT—INSPECTION/REPLACEMENT	129
RECOIL STARTER—DISASSEMBLY	129
RECOIL STARTER—INSPECTION	130
SPRING—REPLACEMENT	131
RECOIL STARTER—ASSEMBLY	131
FB460V (GX95/SRX95)	
ENGINE—REMOVAL/INSTALLATION	132
MUFFLER AND SHIELD (SRX95)—REMOVAL/INSTALLATION	133
MUFFLER AND SHIELD (GX95)—REMOVAL/INSTALLATION	133
BLOWER HOUSING (RECOIL START)—REMOVAL/INSTALLATION	134
BLOWER HOUSING (ELECTRIC START)—REMOVAL/INSTALLATION	134
FLYWHEEL SCREEN—ADJUSTMENT	134
FLYWHEEL—REMOVAL/INSTALLATION	135
BREATHER—REMOVAL/INSTALLATION	135
CYLINDER HEAD—REMOVAL/INSTALLATION	135
CYLINDER HEAD—INSPECTION	136
VALVES AND SPRINGS—REMOVAL/INSTALLATION	136
VALVE SPRINGS AND GUIDES—INSPECTION	136
VALVE GUIDE BUSHINGS—REPLACEMENT	137
RECONDITION VALVE SEATS	137
CHECK VALVE-TO-TAPPET CLEARANCE	138
CRANKCASE COVER—REMOVAL/INSTALLATION	138
CAMSHAFT—REMOVAL/INSTALLATION	139
CAMSHAFT—INSPECTION	139
CAMSHAFT PLAIN BEARINGS—INSPECTION	139
TAPPETS—REMOVAL/INSPECTION/INSTALLATION	140
PISTON AND CONNECTING ROD—REMOVAL/INSTALLATION	140
PISTON AND CONNECTING ROD—DISASSEMBLY/INSPECTION/ASSEMBLY	140
PISTON RINGS—REMOVAL/INSTALLATION	141
CHECK PISTON RING END GAP	141
PISTON—INSPECTION	141
CONNECTING ROD—INSPECTION	142
CRANKSHAFT—REMOVAL/INSPECTION/INSTALLATION	142
RECIPROCATING BALANCER—REMOVAL/INSTALLATION	143
RECIPROCATING BALANCER—DISASSEMBLY/ASSEMBLY	144
BALANCER ASSEMBLY—INSPECTION	144
BALANCER BUSHINGS—REPLACEMENT	145





	Page
FB460V (GX95 AND SRX95)	
CRANKSHAFT PLAIN BEARING—INSPECTION	145
CRANKSHAFT BALL BEARING—INSPECTION	145
CRANKSHAFT—ALIGNMENT	145
CRANKSHAFT END PLAY—MEASUREMENT/ADJUSTMENT	146
OIL SEALS—INSPECTION	146
CYLINDER BLOCK STUDS—REPLACEMENT	147
CYLINDER BLOCK—INSPECTION	147
REBORE CYLINDER BLOCK	148
OIL PUMP—DISASSEMBLY/ASSEMBLY	148
OIL PUMP—INSPECTION	148
OIL FILTER MANIFOLD—REMOVAL/INSPECTION/INSTALLATION	149
GOVERNOR ASSEMBLY—REMOVAL/INSTALLATION	150
GOVERNOR SHAFT—INSPECTION/REPLACEMENT	150
BENCH TEST SOLENOID DRIVE STARTER	151
TEST SOLENOID	151
CHECK STARTER ARMATURE ROTATION	151
TEST STARTER ARMATURE	152
TEST FIELD COIL	152
BRIGGS & STRATTON (GX85/SX85)	
ENGINE—REMOVAL/INSTALLATION	153
MUFFLER AND SHIELD—REMOVAL/INSTALLATION	154
BLOWER HOUSING—REMOVAL/INSTALLATION	154
CYLINDER HEAD AND VALVES—REMOVAL	154
REFACE VALVES AND SEATS	155
TAPPET CLEARANCE—CHECK AND ADJUSTMENT	155
CYLINDER HEAD AND VALVES—INSTALLATION	156
SERVICE VALVE GUIDES	156
SERVICE VALVE SEATS	157
FLYWHEEL—REMOVAL/INSTALLATION	158
CRANKCASE COVER—REMOVAL/INSTALLATION	159
GOVERNOR ASSEMBLY—REMOVAL/INSTALLATION	159
CAMSHAFT AND TAPPETS—REMOVAL/INSTALLATION	159
CRANKSHAFT AND COUNTERBALANCE ASSEMBLY—REMOVAL	160
CRANKSHAFT AND COUNTERBALANCE—INSPECTION	160
CRANKSHAFT AND COUNTERBALANCE ASSEMBLY—INSTALLATION	160
PISTON—REMOVAL	161
PISTON—INSTALLATION	162
MEASURE AND RECONDITION CYLINDER BORE	163
MAGNETO AND CRANKCASE COVER BEARINGS—REPLACEMENT	163
REBUSH MAGNETO BEARING	164
TEST STARTER MOTOR	165
STARTER DRIVE	165
MOTOR REPAIR	167

SPECIFICATIONS—FC290V

ENGINE APPLICATIONS

GX70/GX75 FC290V-BS10
 SRX75 FC290V-CS10

TEST AND ADJUSTMENT SPECIFICATIONS



Engine:

Crankcase Vacuum
 (Minimum at Operating Temp.) 7.0 cm (2.8 in.) of Water Movement

Fuel/Air System:

Carburetor Slow Idle Mixture Screw Initial SettingLightly Seat, then 1-1/2 Turn Out
 Slow Idle Speed 1500 ±75 rpm
 Fast Idle Speed 3300 ±50 rpm

REPAIR SPECIFICATIONS

Fuel and Air Systems

Breather:

Maximum Air Gap 0.20 mm (0.008 in.)

Blower Housing and Flywheel:

Flywheel Nut Torque 85 N•m (63 lb-ft)
 Minimum Flywheel Screen Gap 1.50 mm (0.059 in.)

Cylinder Head and Valves:

Valve Clearance 0.15 mm (0.006 in.)

Rocker Arm:

Minimum Shaft OD 12.94 mm (0.509 in.)
 Maximum Bearing ID 13.07 mm (0.515 in.)

Push Rod:

Maximum Bend 0.30 mm (0.012 in.)
 Intake Pushrod Lift 5.313 mm (0.2092 in.)
 (Wear Minimum) 5.048 mm (0.1987 in.)
 Exhaust Pushrod Lift 5.388 mm (0.2121 in.)
 (Wear Minimum) 5.118 mm (0.2015 in.)

Valves and Springs:

Minimum Spring Free Length	31.00 mm (1.220 in.)
Valve Guide ID	
(Minimum)	7.000 mm (0.2756 in.)
(Maximum)	7.015 mm (0.2762 in.)
Intake Valve Stem OD	
(Minimum)	6.960 mm (0.2740 in.)
(Maximum)	6.975 mm (0.2746 in.)
Intake Valve-to-Guide Clearance	
(Minimum)	0.025 mm (0.0010 in.)
(Maximum)	0.055 mm (0.0022 in.)
Exhaust Valve Stem OD	
(Minimum)	6.950 mm (0.2736 in.)
(Maximum)	6.965 mm (0.0026 in.)
Exhaust Valve-to-Guide Clearance	
(Minimum)	0.035 mm (0.0014 in.)
(Maximum)	0.065 mm (0.0026 in.)
Intake Valve Lift (W/Clearance set at 0.00)	6.923 mm(0.2726 in.)
(Wear Minimum)	6.578 mm(0.2590 in.)
Exhaust Valve Lift (W/Clearance set at 0.00)	7.021 mm (0.2764 in.)
(Wear Minimum)	6.670 mm (0.2626 in.)
Maximum Valve Stem Bend	0.03 mm (0.001 in.)
Valve Seating Surface	0.50—1.10 mm (0.020—0.043 in.)
Valve Seat and Face Angle	45°
Minimum Valve Margin	0.60 mm (0.020 in.)
Valve Narrowing Angle	30°

Cylinder Head:

Cylinder Head Flatness	0.05 mm (0.002 in.)
Cap Screw Torque in Sequence (Lubricated)	
Initial Torque	18 N•m (159 lb-in.)
Final Torque	24 N•m (18 lb-ft)
Spark Plug Torque	20 N•m (177 lb-in.)

Crankcase Cover:

Oil Capacity	1.1 L (1.16 qt)
Cap Screw Torque	20 N•m (177 lb-in.)

Camshaft:

Minimum End Journal OD	
PTO Side	13.92 mm (0.548 in.)
Flywheel Side	15.92 mm (0.627 in.)
Minimum Lobe Height	27.08 mm (1.066 in.)
Maximum Bearing ID	
Crankcase	16.06 mm (0.632 in.)
Oil Pump Cover	14.05 mm (0.553 in.)

Reciprocating Balancer

Link Rod	
Minimum Journal OD	46.86 mm (1.845 in.)
Maximum Small End ID	12.06 mm (0.475 in.)
Maximum Large End ID	47.12 mm (0.855 in.)
Bushing Depth	1 mm (0.040 in.)



Balancer Weight:

Maximum Bearing ID 26.10 mm (1.027 in.)

Support Shaft:

Minimum Shaft OD 25.93 mm (1.021 in.)
 Support Shaft Assembly Torque 7.3 N•m (65 lb-in.)

Piston:

Maximum Ring Groove Clearance
 Top Ring 0.16 mm (0.006 in.)
 Second Ring 0.14 mm (0.005 in.)
 Oil Control Ring 0.19 mm (0.007 in.)
 Minimum Ring End Gap 0.18 mm (0.007 in.)
 Maximum Ring End Gap
 Compression Rings 0.71 mm (0.028 in.)
 Oil Ring Side Rails 1.20 mm (0.047 in.)
 Minimum Pin OD 18.98 mm (0.747 in.)
 Maximum Pin Bore ID 19.03 mm (0.749 in.)
 Maximum Piston-to-Piston Pin Clearance 0.05 mm (0.002 in.)
 Piston OD 77.85—77.87 mm (3.0649—3.0657 in.)
 Piston-to-Cylinder Bore Clearance 0.110—0.142 mm (0.0043—0.0056 in.)

Connecting Rod:

Maximum Crankshaft Bearing ID 35.57 mm (1.400 in.)
 Maximum Piston Pin Bearing ID 19.06 mm (0.750 in.)
 Maximum Connecting Rod-to-Piston Pin Clearance 0.08 mm (0.003 in.)
 Maximum Connecting Rod-to-Crankpin Clearance 0.14 mm (0.006 in.)
 End-Cap Screw Torque 20 N•m (177 lb-in.)

Crankshaft:

Minimum PTO Side Journal OD 29.92 mm (1.178 in.)
 Minimum Connecting Rod Journal OD 35.43 mm (1.395 in.)
 Maximum Crankcase Cover Plain Bearing ID 30.13 mm (1.186 in.)
 Maximum T.I.R. 0.05 mm (0.002 in.)
 End Play 0.09—0.22 mm (0.004—0.009 in.)

Cylinder Bore:

Standard Cylinder Bore ID 77.98—78.00 mm (3.070—3.071 in.)
 Maximum Cylinder Bore ID 78.07 mm (3.074 in.)

Rebore Cylinder:

Oversize Diameter
 0.25 mm 78.21—78.23 mm (3.079—3.080 in.)
 0.50 mm 78.46—78.48 mm (3.089—3.090 in.)
 0.75 mm 78.71—78.73 mm (3.099—3.100 in.)

Ignition Module:

Ignition Coil Air Gap 0.30 mm (0.012 in.)



SPECIFICATIONS—FB460V

ENGINE APPLICATIONS

GX95 and SRX95 FB460V-BS25

TEST AND ADJUSTMENT SPECIFICATIONS



Engine:

Oil Pressure (Minimum at 1250 rpm) 240 kPa (35 psi)
 Crankcase Vacuum
 (Minimum at Operating Temp.) 25 cm (9.8 in.) of Water Movement

Fuel/Air System:

Fuel Pump Minimum Fuel Flow 90 mL (3.15 oz.) in 10 seconds
 Carburetor Slow Idle Mixture Screw Initial Setting Lightly Seat, then 1-1/8 Turn Out
 Slow Idle Speed 1400 ±75 rpm
 Fast Idle Speed 3300 ±50 rpm

REPAIR SPECIFICATIONS

Blower Housing and Flywheel:

Flywheel Nut Torque 88 N•m (65 lb-ft)
 Flywheel Screen Gap 1—3 mm (0.039—0.118 in.)

Cylinder Head:

Maximum Cylinder Head Warp 0.40 mm (0.015 in.)
 Cap Screw Torque in Sequence (Lubricated)
 Initial Torque 23 N•m (17 lb-ft)
 Final Torque 37 N•m (27 lb-ft)
 Spark Plug Torque 24 N•m (18 lb-ft)
 Valve Clearance (Cold) 0.10—0.16 mm (0.004—0.006 in.)

Valves and Springs:

Minimum Spring Free Length
 Intake 43 mm (1.710 in.)
 Exhaust 39 mm (1.540 in.)
 Maximum Valve Guide ID 8.08 mm (0.318 in.)
 Valve Guide Bushing Depth 30 mm (1.178 in.)
 Maximum Valve Stem Bend 0.03 mm (0.001 in.)
 Valve Seat and Face Angle 45°
 Valve Seating Width 1.30 mm (0.050 in.)
 Valve Margin 0.60 mm (0.020 in.)
 Valve Narrowing Angle 30°

Crankcase Cover:

Oil Capacity	
With Filter	1.6 L (1.69 qt)
Without Filter	1.4 L (1.48 qt)
Cap Screw Torque	20 N•m (177 lb-in.)

Camshaft:

Minimum End Journal OD	
PTO Side	19.91 mm (0.784 in.)
Magneto Side	15.91 mm (0.627 in.)
Minimum Lobe Height	35.40 mm (1.395 in.)
Maximum Bearing ID	
Crankcase	16.07 mm (0.633 in.)
Oil Pump Cover	20.07 mm (0.790 in.)

**Reciprocating Balancer:**

Link Rod	
Minimum Journal OD	53.95 mm (2.124 in.)
Maximum Small End ID	12.60 mm (0.475 in.)
Maximum Large End ID	54.12 mm (2.132 in.)
Bushing Depth	0.50 mm (0.020 in.)

Balancer Weight:

Maximum Bearing ID	26.10 mm (1.027 in.)
------------------------------	----------------------

Support Shaft:

Minimum Shaft OD	25.93 mm (1.021 in.)
Support Shaft Assembly Torque	7.3 N•m (65 lb-in.)

Piston:

Maximum Ring Groove Clearance	
Top Ring	0.16 mm (0.006 in.)
Second Ring	0.14 mm (0.005 in.)
Oil Control Ring	0.19 mm (0.007 in.)
Minimum Ring End Gap	0.18 mm (0.007 in.)
Maximum Ring End Gap	
Compression Rings	0.7 cm (0.028 in.)
Oil Ring Side Rails	1.20 mm (0.047 in.)
Minimum Pin OD	20.98 mm (0.827 in.)
Maximum Pin Bore ID	21.03 mm (0.829 in.)
Maximum Piston-to-Piston Pin Clearance	0.05 mm (0.002 in.)
Piston OD	88.81—88.83 mm (3.4991—3.4999 in.)
Piston-to-Cylinder Bore Clearance	0.156 mm (0.0061 in.)

Connecting Rod:

Maximum Crankshaft Bearing ID	37.02 mm (1.459 in.)
Maximum Piston Pin Bearing ID	21.01 mm (0.829 in.)
Maximum Connecting Rod-to-Piston Pin Clearance	0.03 mm (0.001 in.)
Maximum Connecting Rod-to-Crankpin Clearance	0.09 mm (0.004 in.)
End-Cap Screw Torque	20 N•m (177 lb-in.)

Crankshaft:

Minimum PTO Side Journal OD	34.91 mm (1.374 in.)
Minimum Connecting Rod Journal OD	36.95 mm (1.455 in.)
Maximum Crankcase Cover Plain Bearing ID	35.06 mm (1.380 in.)
Maximum T.I.R.	0.05 mm (0.002 in.)
End Play	0.09—0.22 mm (0.004—0.009 in.)



PTO Side Oil Seal:

Depth.	0.50 mm (0.020 in.)
----------------	---------------------

Cylinder Block:

Crankcase/Block Stud Torque	36 N•m (27 lb-ft)
---------------------------------------	-------------------

Cylinder Bore:

Standard Cylinder Bore ID	88.90—89.00 mm (3.500—3.504 in.)
Maximum Cylinder Bore ID	89.06 mm (3.506 in.)
Maximum Out-of-Round	0.063 mm (0.0025 in.)
Maximum Taper.	0.076 mm (0.003 in.)

Rebore Cylinder:

Oversize Diameter	
0.25 mm	89.21—89.23 mm (3.512—3.513 in.)
0.50 mm	89.46—89.48 mm (3.522—3.523 in.)
0.75 mm	89.71—89.73 mm (3.532—3.533 in.)

Oil Pump:

Cover Cap Screw Torque	17—23 N•m (150—204 lb-in.)
Minimum Rotor Shaft ID	12.63 mm (0.497 in.)
Maximum Rotor Shaft Bearing ID	12.76 mm (0.502 in.)
Outer Rotor	
Minimum thickness	11.92 mm (0.470 in.)
Minimum OD	28.90 mm (1.139 in.)
Outer Rotor Bearing	
Maximum Depth	12.14 mm (0.478 in.)
Maximum ID	29.15 mm (1.148 in.)
Minimum Valve Spring Free Length	19.00 mm (0.750 in.)

Ignition Module:

Ignition Coil Air Gap	0.30 mm (0.012 in.)
---------------------------------	---------------------

SPECIFICATIONS—BRIGGS & STRATTON

ENGINE APPLICATIONS

GX85 and SX85 Briggs & Stratton

TEST AND ADJUSTMENT SPECIFICATIONS



Engine:

Oil Pressure (Minimum at 1250 rpm) 3.6 kPa (0.5 psi)

Fuel/Air System:

Fuel Pump Minimum Fuel Flow 90 mL (3.15 oz.) in 15 seconds

Carburetor Slow Idle Mixture Screw Initial Setting Lightly Seat, then 1-1/2 Turn Out

Slow Idle Speed 1550—1850 rpm

Fast Idle Speed 3150—3450 rpm

REPAIR SPECIFICATIONS

Flywheel Nut Torque 88 N•m (65 lb-ft)

Engine Drive Sheave Cap Screw Torque 73 N•m (54 lb-ft)

Engine-to-Frame Cap Screw Torque 48 N•m (35 lb-ft)

Carburetor Mounting Screw Torque 7.5 N•m (66 lb-in.)

Muffler Mounting Screw Torque 15.5 N•m (137 lb-in.)

Starter Mounting Screw Torque 16 N•m (137 lb-in.)

Drain Plug Torque 14 N•m (124 lb-in.)

Cylinder Head Cap Screw Torque (Lubricated) 19 N•m (168 lb-in.)

Spark Plug Torque 19 N•m (168 lb-in.)

Crankcase Sump Cover Cap Screw Torque 22.6 N•m (200 lb-in.)

Oil Capacity:

With Filter 1.6 L (3.38 pt)

Without Filter 1.4 L (2.96 pt)

Valves:

Valve Seat and Face Angle (Intake) 30°

Valve Seat and Face Angle (Exhaust) 45°

Valve Seating Width (Min) 1.17 mm (0.031 in.)

Valve Seating Width (Max) 1.17 mm (3/64 in.)

Valve Margin Greater Than 0.40 mm (1/64 in.)

Valve Narrowing Angle 30°

Intake Valve Clearance 0.13—0.18 mm (0.005—0.007 in.)

Exhaust Valve Clearance 0.23—0.28 (0.009—0.011 in.)

Exhaust Guide ID 7.938—7.963 mm (0.3125—0.3135 in.)

Intake Guide ID 7.912—7.938 mm (0.3115—0.3125 in.)

Intake and Exhaust Valve Stem Dia. 7.848—7.874 mm (0.309—0.310 in.)

Camshaft:

Minimum Journal OD (Rejection Size)	12.65 mm (0.498 in.)
Maximum Bearing ID (Rejection Size)	12.80 mm (0.504 in.)
PTO Bearing ID (Standard Size)	12.73—12.75 mm (0.501—0.502 in.)
Lobe Height (Rejection Size)	30.08 mm (1.184 in.)

Counterbalance:

Eccentric (Minimum)	55.93 mm (2.202 in.)
Bearing (Minimum)	56.18 mm (2.212 in.)
Cap Screw Torque	13 N•m (115 lb-in.)

Piston:

Ring-to-Land Clearance (Rejection)	0.317 mm (0.0125 in.)
Ring End Gap Top and Center (Rejection)	0.76 mm (0.030 in.)
Ring End Gap Oil Control (Reject)	0.89 mm (0.035 in.)
Piston Pin ID Reject Size.	20.307 mm (0.7995 in.)
Piston Pin Bearing ID Rejection Size.	20.409 mm (0.8035 in.)
Max. Bore Size	87.313 mm (3.4375 in.)
Upper Bore OD Size	(1.6825 in.)
Upper Crankshaft Seal Size	(1.691 in.)

Connecting Rod:

Crankpin Bearing ID Reject Size.	31.80 mm (1.252 in.)
Crankpin Bearing ID Standard Size.	31.750—31.763 mm (1.2500—1.2505 in.)
Piston Pin Bearing ID Reject Size.	20.37 mm (0.802 in.)
Piston Pin Bearing ID Standard Size.	20.335—20.350 mm (0.8006—0.8012 in.)
End-Cap Screw Torque	20.91 N•m (185 lb-in.)

Undersize Connecting Rod Crankpin Grinding Dimensions:

Crankpin Diameter	31.224—31.214 mm (1.2293—1.2289 in.)
Fillet Radius	3.30—3.05 mm (0.130—0.120 in.)
Crankshaft Throw	33.388—33.287 mm (1.3145—1.3105 in.)

Crankshaft:

Main Bearing ID (Magneto Side) Rejection Size	35.13 mm (1.383 in.)
Main Bearing ID (PTO Side) Rejection Size	35.26 mm (1.388 in.)
Minimum Connecting Rod Journal OD Rejection Size.	31.67 mm (1.247 in.)
Journal OD (Magneto and PTO Side) Rejection Size	34.95 mm (1.376 in.)
End Play	0.051—0.762 mm (0.002—0.030 in.)

Ignition Module:

Ignition Coil Air Gap	0.30 mm (0.012 in.)
---------------------------------	---------------------



ENGINE COMPONENT LOCATION—"K" SERIES FC290V

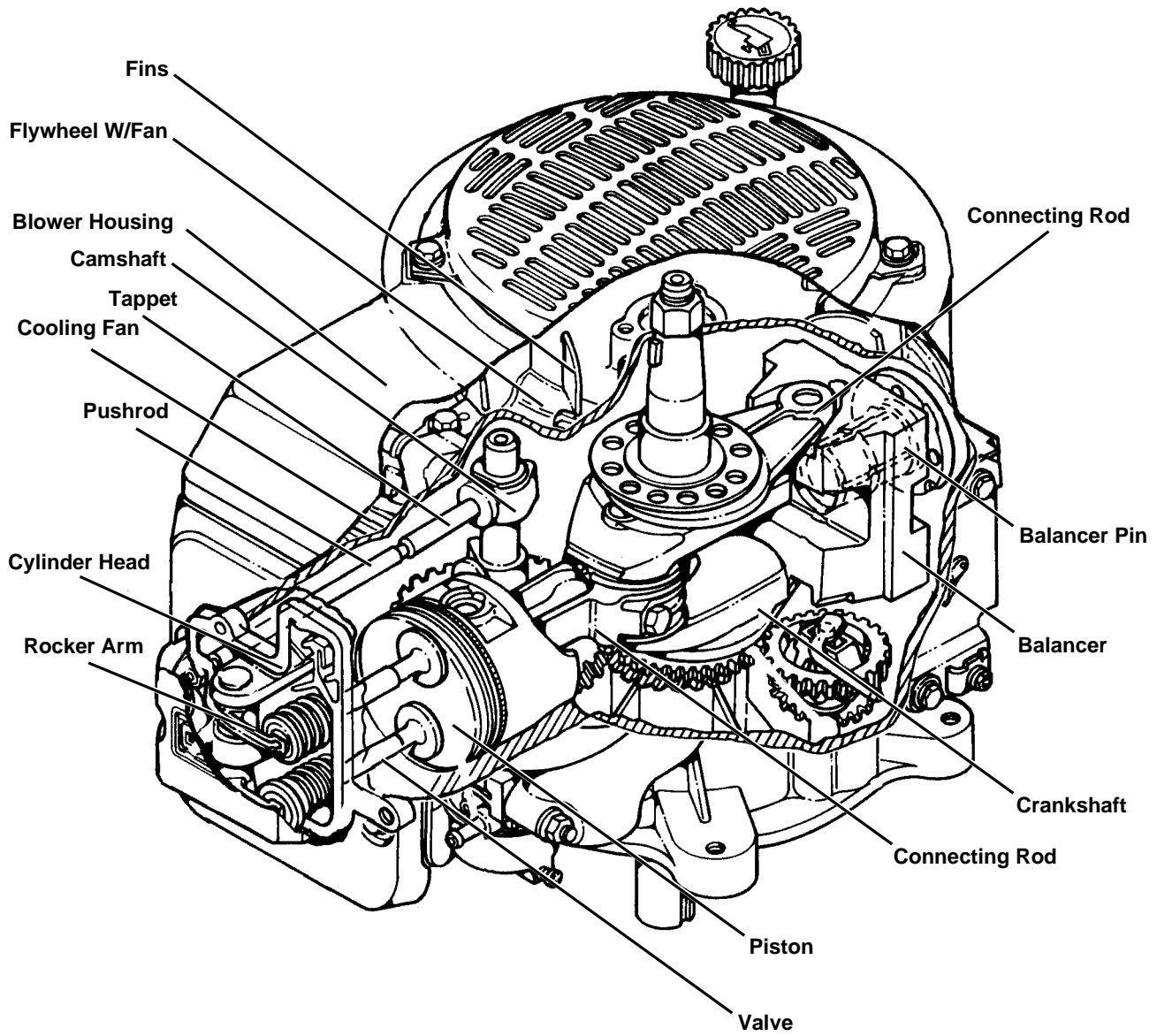

M49460

ENGINE COMPONENT LOCATION—"K" SERIES FB460V

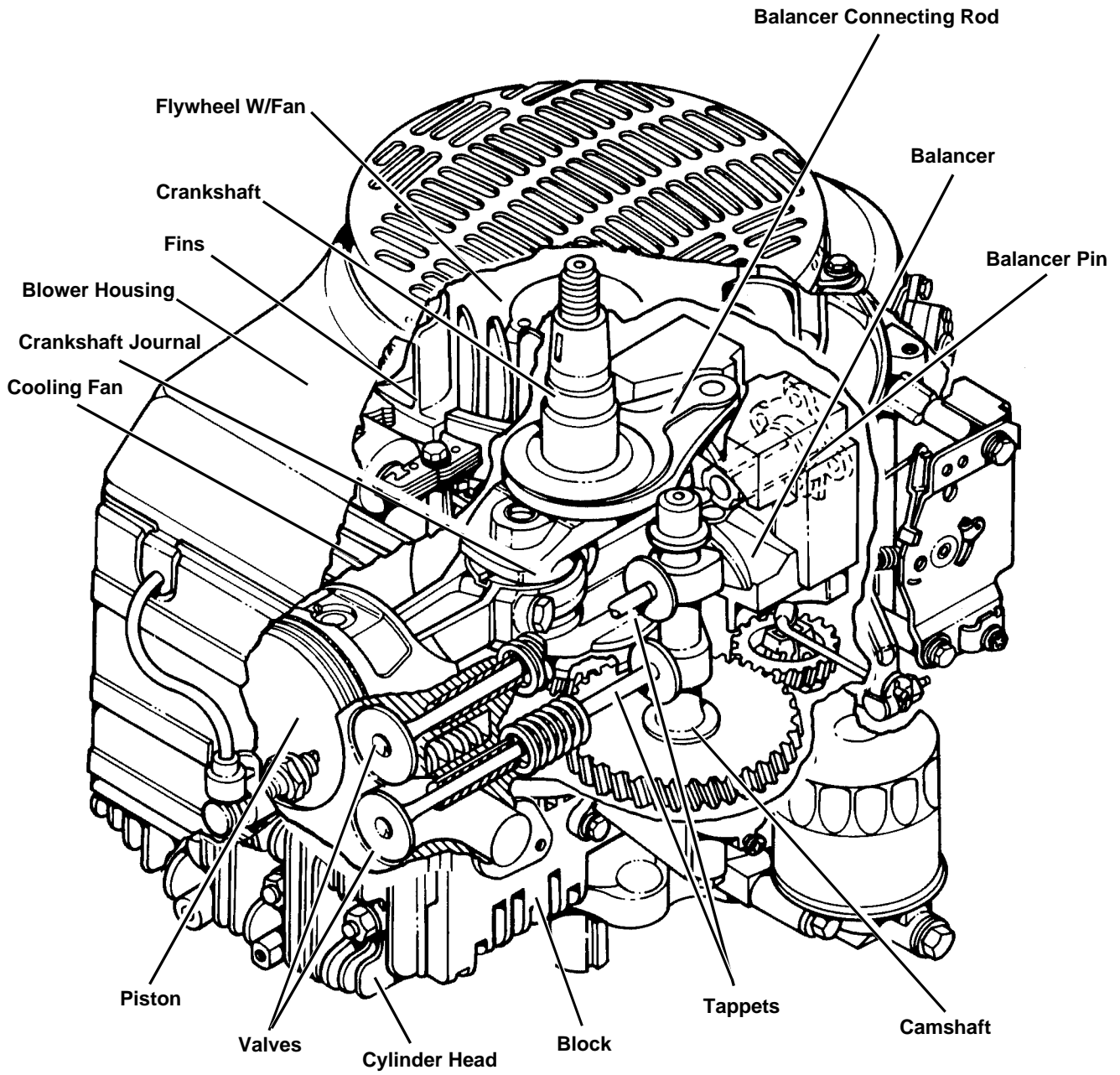

M49623

THEORY OF OPERATION—"K" SERIES FC290V

GOVERNOR OPERATION

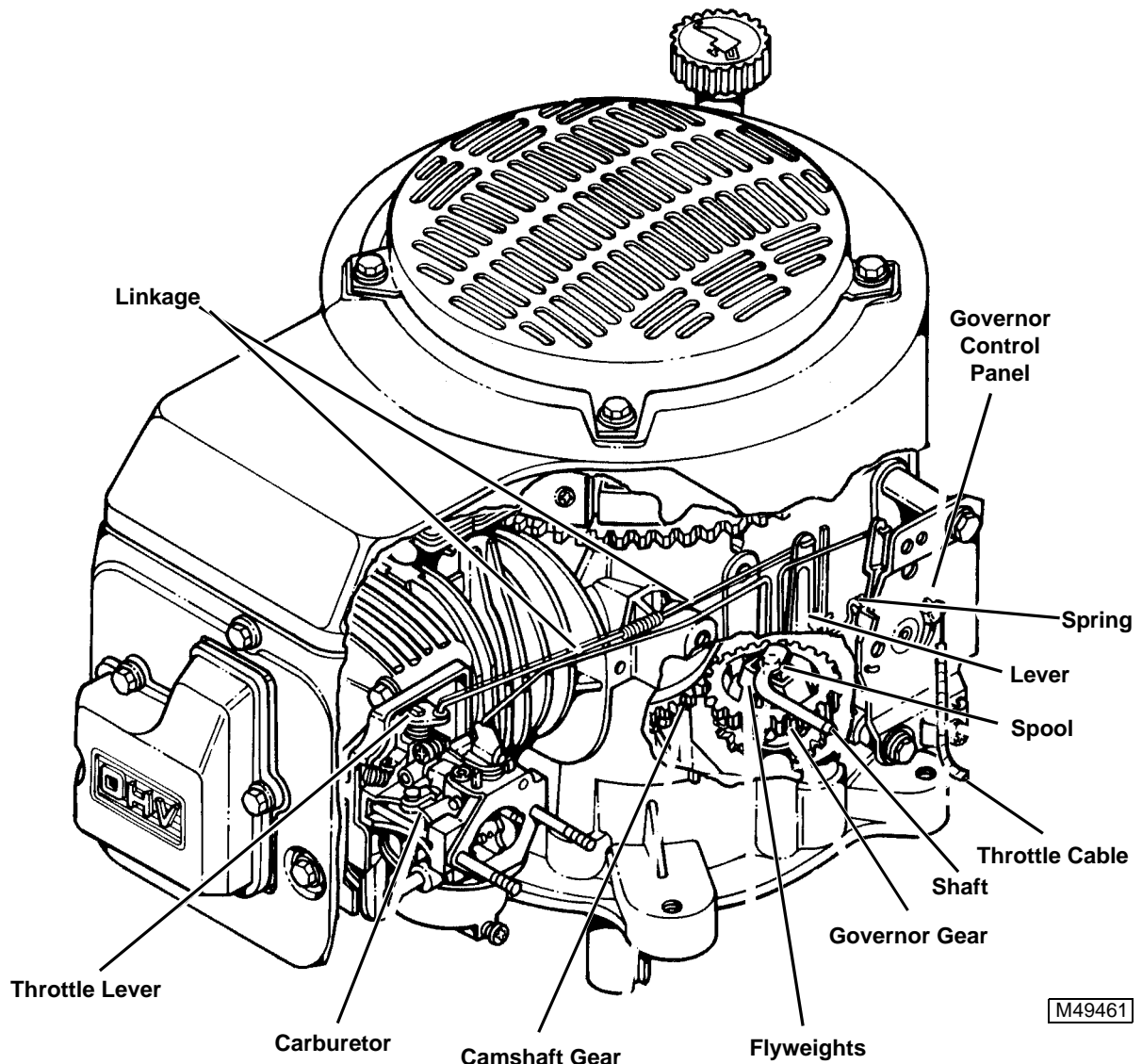
**Theory of Operation:**

The governor system senses the engine rpms by the position of the flyweights. These flyweights are rotated by the governor gear that is driven by the camshaft gear. The flyweights press against spool that rotates the shaft and lever. This lever is connected to the throttle lever of the carburetor by linkage. As engine rpms increase, the movement of the flyweights tries to close the throttle valve. This movement is opposed by a spring at the control panel. The tension of this spring can be changed by changing the position of the throttle cable. As the throttle is advanced, the tension of the spring is increased and the governed rpms increase. The maximum rpm is controlled by a stop on the control panel. As the load on the engine increases, the rpms will drop. This allows the spring to pull on the

linkage and open the throttle valve that increases the power and raises the rpms. When the load decreases, the rpms increase, which causes the flyweights to move the linkage and close the throttle valve. The power is lowered and the rpms drop. The chosen rpm is maintained by the balancing of the forces of the flyweights and the spring.

COMPRESSION RELEASE OPERATION

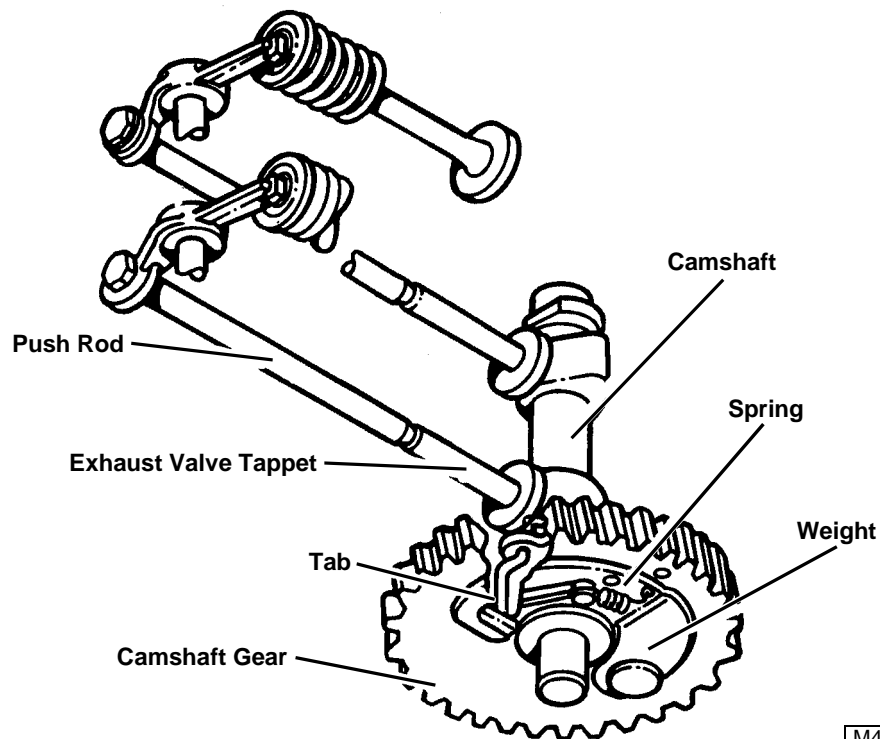

M49467

Theory of Operation:

The compression release on this engine consists of a release tab, weight and spring that are mounted on gear of the camshaft. The release tab holds the exhaust valve tappet and push rod off its seat during a portion of the compression stroke. The release tab is connected to the weight and the spring holds the weight in at low rpms. As the engine starts and the rpms increase, the weight overcomes the spring and moves out. As it moves out, the release tab moves in until it clears the valve tappet. The exhaust valve seats properly and full compression is obtained. Valve lash is important for correct operation. Too much lash and compression will be high; too little and compression will be low.

LUBRICATION SYSTEM OPERATION

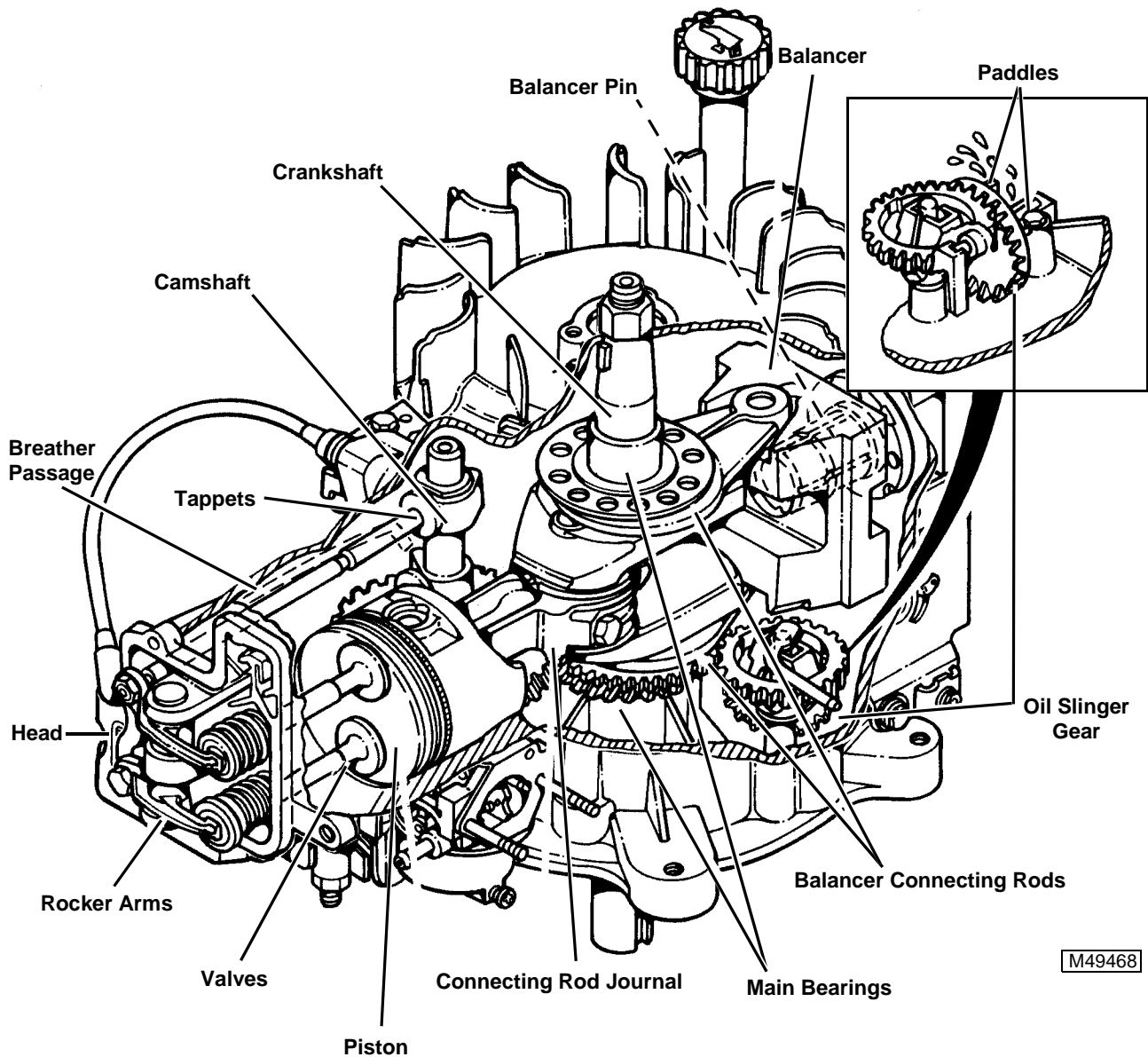
**Theory of Operation:**

The lubrication of the internal components of the engine is from splashed oil or oil-laden air. The piston, connecting rod journal, crankshaft main bearings, balancer rods and balancer pin are lubricated by splashed oil. Oil is splashed around the crankcase by the paddles on the oil slinger gear. The slinger gear is driven by the governor gear. During operation, the air in the crankcase becomes very oily. This air travels out the breather passage into the head. This oil/air mixture lubricates the rocker arms and valves. Lubrication of the camshaft and tappets is by splash.

CRANKCASE OPERATION

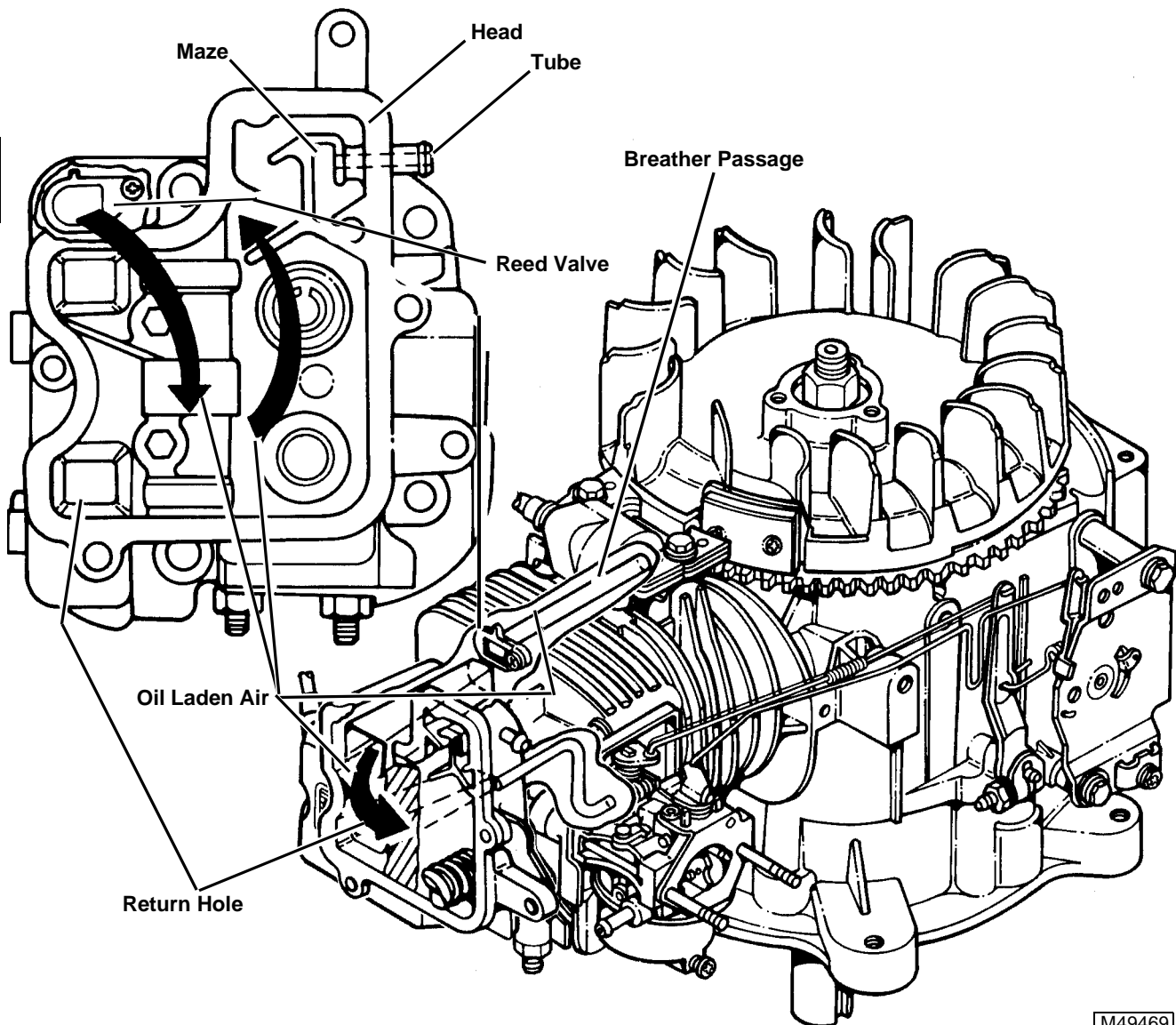

M49469

Theory of Operation:

The breather consists of a reed valve that controls the flow of air out of and into the crankcase. As the piston moves in during power and intake strokes, the volume in the crankcase decreases. To prevent a build-up of pressure, oil-laden air is allowed to freely flow out through the breather passage, past the reed valve into the head. In the head some of the oil separates from the air and returns to the crankcase through the return hole. The air then passes into the maze. In the maze more oil separates from the air and also returns through the return hole. The air then passes through a tube which connects to the air cleaner housing of the carburetor. The air is routed to burn oil vapors and keep them out of the atmosphere. As the crankshaft continues to rotate and the piston goes out for compression or exhaust strokes, the volume in the crankcase increases and the air that was let out tries to

get back in. But the reed valve is now closed and the return hole is below the level of the oil in the crankcase so only a small amount of air can get back in through the return hole. A vacuum is created.

FUEL/AIR SUPPLY SYSTEM OPERATION

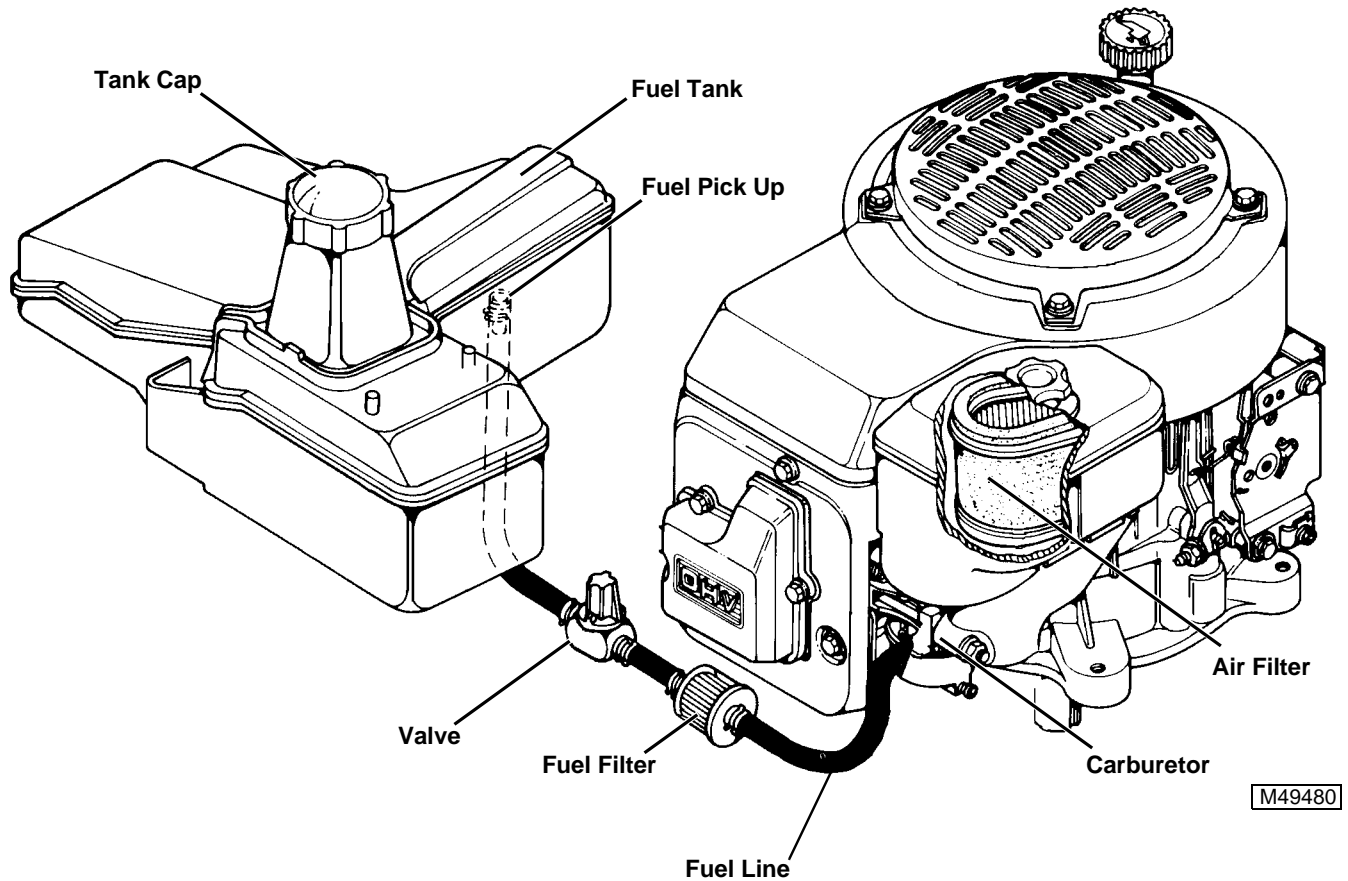

Function:

Under a variety of conditions, supplies the correct amount of fuel and air to the engine to allow it to run.

Theory of Operation:

The fuel supply for this engine is a gravity-feed type. Fuel flows from the tank through the fuel filter and fuel shutoff valve to the carburetor where it is metered to supply the correct amount for the various operating conditions. The vent for the fuel tank is a notch in the threads of the fuel tank cap.

The air supply is drawn into the air filter housing through the air filter elements. This filter is a two-stage design consisting of a paper element and a foam element. The air inlet to the filter housing is connected to the engine fan shroud so the air supplied to the carburetor is controlled by the engine cooling fan. Any blockage of the air flow on the fins of the engine will alter the air supply to the carburetor and can change engine performance and operation.



Suggest:

If the above button click is invalid.

Please download this document

first, and then click the above link

to download the complete manual.

Thank you so much for reading

THEORY OF OPERATION—"K" SERIES FB460V

GOVERNOR OPERATION

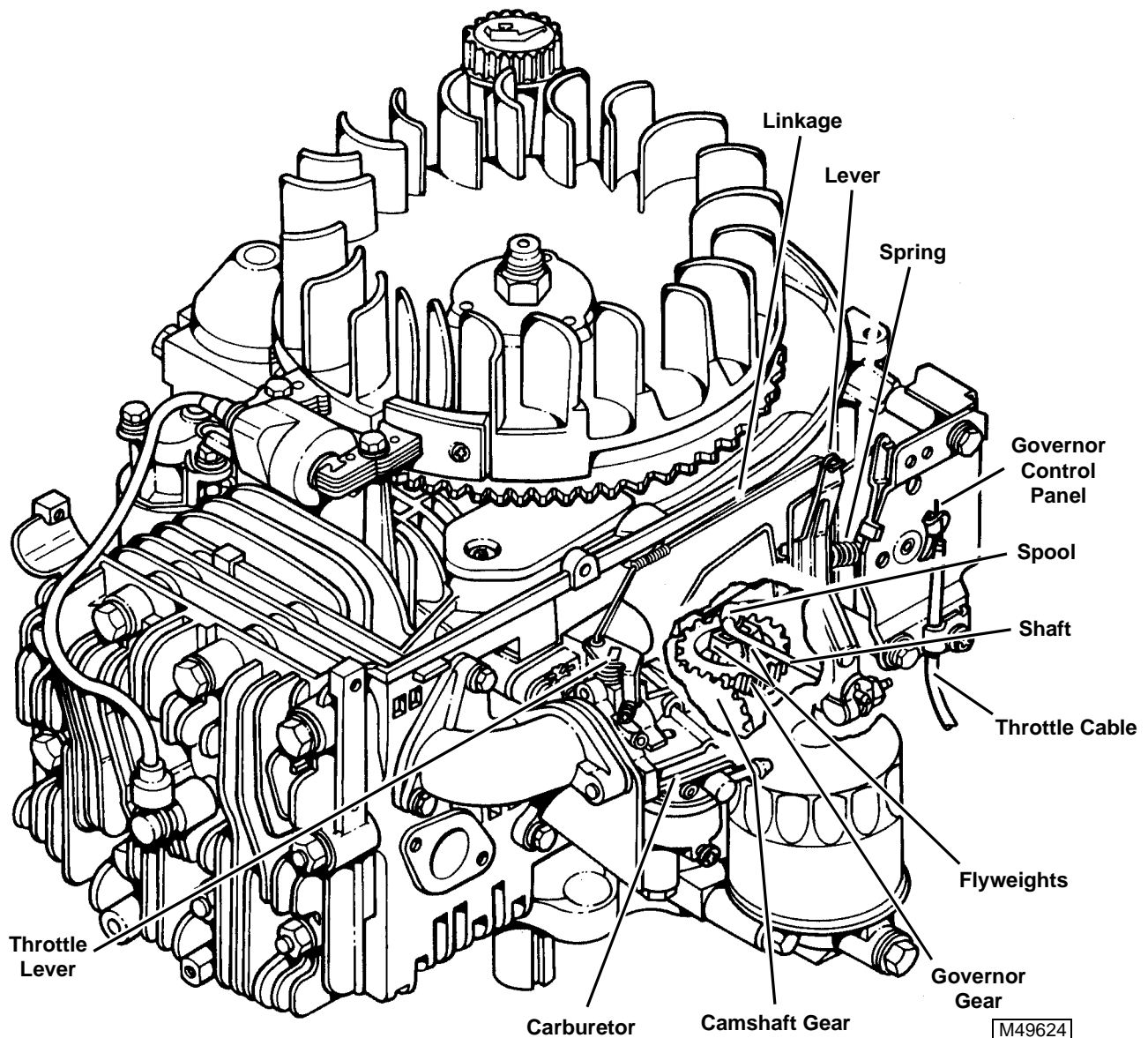
**Theory of Operation:**

The governor system senses engine rpms by the position of the flyweights. These flyweights are rotated by the governor gear that is driven by the camshaft gear. The flyweights press against spool that rotates the shaft and lever. This lever is connected to the throttle lever of the carburetor by linkage. As engine rpms increase, the movement of the flyweights tries to close the throttle valve. This movement is opposed by spring at the control panel. The tension of this spring can be changed by changing the position of the throttle cable.

As the throttle is advanced, the tension of the spring is increased and the governed rpms increase. The maximum rpm is controlled by a stop on the control panel. As the load on the engine increases, the rpms will drop. This allows the spring to pull on the linkage and open the throttle valve that increases the power and raises the rpms. When the load decreases, the rpms increase causes the flyweights to move the linkage and close the throttle valve. The power is lowered and the rpms drop. The chosen rpm is maintained by the balancing of the forces of the flyweights and the spring.

<https://www.ebooklibonline.com>

Hello dear friend!

Thank you very much for reading.

Enter the link into your browser.

The full manual is available for immediate download.

<https://www.ebooklibonline.com>