

**JOHN DEERE**  
**AG & TURF DIVISION**

---

**M-Gator**  
**A3**

TM115719 SEPTEMBER 2011

**TECHNICAL MANUAL**



**JOHN DEERE**

North American Version  
Litho In U.s.a.

# INTRODUCTION

## Manual Description

This technical manual is written for an experienced technician and contains sections that are specifically for this product. It is a part of a total product support program.

The manual is organized so that all the information on a particular system is kept together. The order of grouping is as follows:

- Table of Contents
- Specifications and Information
- Identification Numbers
- Tools and Materials
- Component Location
- Schematics and Harnesses
- Theory of Operation
- Operation and Diagnostics
- Diagnostics
- Tests and Adjustments
- Repair
- Other

**Note: Depending on the particular section or system being covered, not all of the above groups may be used.**

The bleed tabs for the pages of each section will align with the sections listed on this page. Page numbering is consecutive from the beginning of the Safety section through the last section.

We appreciate your input on this manual. If you find any errors or want to comment on the layout of the manual please contact us.

Safety

Specifications and Information

Engine

Electrical

Power Train

Steering

Brakes

Miscellaneous

All information, illustrations and specifications in this manual are based on the latest information at the time of publication. The right is reserved to make changes at any time without notice.

COPYRIGHT© 2011  
Deere & Co.

John Deere Ag & Turf Division  
All rights reserved  
Previous Editions  
COPYRIGHT©

# SAFETY

## Safety

### Recognize Safety Information



MIF

This is the safety-alert symbol. When you see this symbol on your machine or in this manual, be alert to the potential for personal injury.

Follow recommended precautions and safe servicing practices.

### Understand Signal Words

A signal word - DANGER, WARNING, or CAUTION - is used with the safety-alert symbol. DANGER identifies the most serious hazards.

DANGER or WARNING safety signs are located near specific hazards. General precautions are listed on CAUTION safety signs. CAUTION also calls attention to safety messages in this manual.

### Replace Safety Signs

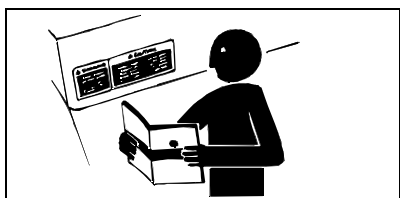

MIF

Replace missing or damaged safety signs. See the machine operator's manual for correct safety sign placement.

### Handle Fluids Safely - Avoid Fires

#### Be Prepared For Emergencies

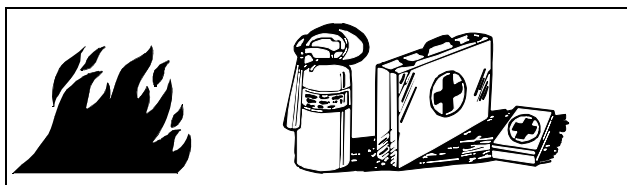

MIF

- When you work around fuel, do not smoke or work near heaters or other fire hazards.

- Store flammable fluids away from fire hazards. Do not incinerate or puncture pressurized containers.
- Make sure machine is clean of trash, grease, and debris.
- Do not store oily rags; they can ignite and burn spontaneously.
- Be prepared if a fire starts.
- Keep a first aid kit and fire extinguisher handy.
- Keep emergency numbers for doctors, ambulance service, hospital, and fire department near your telephone.

### Use Care In Handling And Servicing Batteries

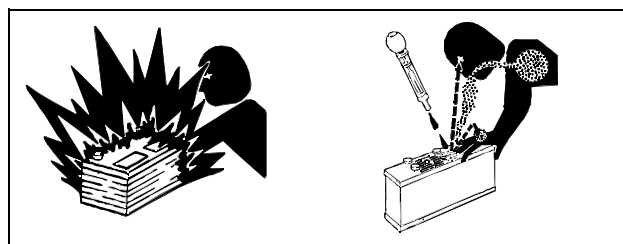

MIF

#### Prevent Battery Explosions

- Keep sparks, lighted matches, and open flame away from the top of battery. Battery gas can explode.
- Never check battery charge by placing a metal object across the posts. Use a volt-meter or hydrometer.
- Do not charge a frozen battery; it may explode. Warm battery to 16°C (60°F).

#### Prevent Acid Burns

- Sulfuric acid in battery electrolyte is poisonous. It is strong enough to burn skin, eat holes in clothing, and cause blindness if splashed into eyes.

#### Avoid acid burns by:

- Filling batteries in a well-ventilated area.
- Wearing eye protection and rubber gloves.
- Avoiding breathing fumes when electrolyte is added.
- Avoiding spilling or dripping electrolyte.
- Use proper jump start procedure.

#### If you spill acid on yourself:

- Flush your skin with water.
- Apply baking soda or lime to help neutralize the acid.
- Flush your eyes with water for 10 - 15 minutes.
- Get medical attention immediately.

**<https://www.ebooklibonline.com>**

Hello dear friend!

Thank you very much for reading.

Enter the link into your browser.

The full manual is available for immediate download.

**<https://www.ebooklibonline.com>**

# SAFETY

## If acid is swallowed:

1. Drink large amounts of water or milk.
2. Then drink milk of magnesia, beaten eggs, or vegetable oil.
3. Get medical attention immediately.

## Wear Protective Clothing

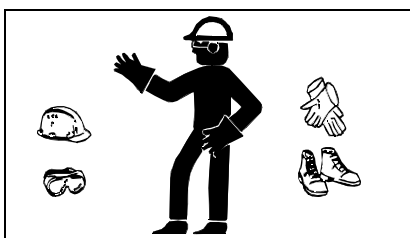

MIF

Wear close fitting clothing and safety equipment appropriate to the job.

Prolonged exposure to loud noise can cause impairment or loss of hearing. Wear a suitable hearing protective device such as earmuffs or earplugs to protect against objectionable or uncomfortable loud noises.

Operating equipment safely requires the full attention of the operator. Do not wear radio or music headphones while operating machine.

## Use Care Around High-pressure Fluid Lines

### Avoid High-Pressure Fluids

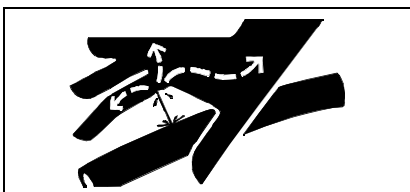

MIF

Escaping fluid under pressure can penetrate the skin causing serious injury.

Avoid injury from escaping fluid under pressure by stopping the engine and relieving pressure in the system before disconnecting or connecting hydraulic or other lines. Tighten all connections before applying pressure.

Search for leaks with a piece of cardboard. Protect hands and body from high pressure fluids.

If an accident occurs, see a doctor immediately. Any fluid injected into the skin must be surgically removed within a few hours or gangrene may result. Doctors unfamiliar with this type of injury should reference a knowledgeable medical source. Such information is available from Deere & Company Medical Department in Moline, Illinois, U.S.A.

## Avoid Heating Near Pressurized Fluid Lines



MIF

Flammable spray can be generated by heating near pressurized fluid lines, resulting in severe burns to yourself and bystanders. Do not heat by welding, soldering, or using a torch near pressurized fluid lines or other flammable materials. Pressurized lines can be accidentally cut when heat goes beyond the immediate flame area.

## Service Machines Safely

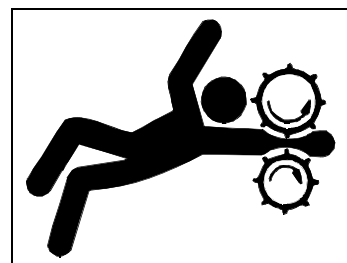

MIF

Tie long hair behind your head. Do not wear a necktie, scarf, loose clothing, or necklace when you work near machine tools or moving parts. If these items were to get caught, severe injury could result.

Remove rings and other jewelry to prevent electrical shorts and entanglement in moving parts.

## Support Machine Properly and Use Proper Lifting Equipment

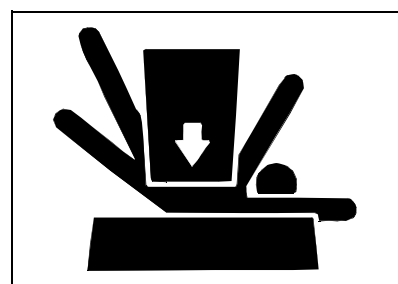

MIF

If you must work on a lifted machine or attachment, securely support the machine or attachment.

Do not support the machine on cinder blocks, hollow tiles, or props that may crumble under continuous load. Do not work under a machine that is supported solely by a jack.

# SAFETY

Follow recommended procedures in this manual.

Lifting heavy components incorrectly can cause severe injury or machine damage. Follow recommended procedure for removal and installation of components in the manual.

## Work In Clean Area

### Before starting a job:

1. Clean work area and machine.
2. Make sure you have all necessary tools to do your job.
3. Have the right parts on hand.
4. Read all instructions thoroughly; do not attempt shortcuts.

## Using High Pressure Washers

Directing pressurized water at electronic/electrical components or connectors, bearings, hydraulic seals, fuel injection pumps or other sensitive parts and components may cause product malfunctions. Reduce pressure and spray at a 45 to 90 degree angle.

## Illuminate Work Area Safely

Illuminate your work area adequately but safely. Use a portable safety light for working inside or under the machine. Make sure the bulb is enclosed by a wire cage. The hot filament of an accidentally broken bulb can ignite spilled fuel or oil.

## Work In Ventilated Area

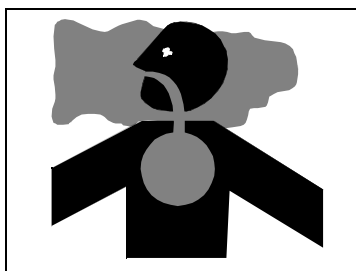

MIF

Engine exhaust fumes can cause sickness or death. If it is necessary to run an engine in an enclosed area, remove the exhaust fumes from the area with an exhaust pipe extension.

If you do not have an exhaust pipe extension, open the doors and get outside air into the area.

## Service Tires Safely



MIF

Explosive separation of a tire and rim parts can cause serious injury or death.

Do not attempt to mount a tire unless you have the proper equipment and experience to perform the job.

Always maintain the correct tire pressure. Do not inflate the tires above the recommended pressure. Never weld or heat a wheel and tire assembly. The heat can cause an increase in air pressure resulting in a tire explosion. Welding can structurally weaken or deform the wheel.

When inflating tires, use a clip-on chuck and extension hose long enough to allow you to stand to one side and NOT in front of or over the tire assembly. Use a safety cage if available.

Check wheels for low pressure, cuts, bubbles, damaged rims or missing lug bolts and nuts.

## Avoid Injury From Rotating Blades, Augers And PTO Shafts

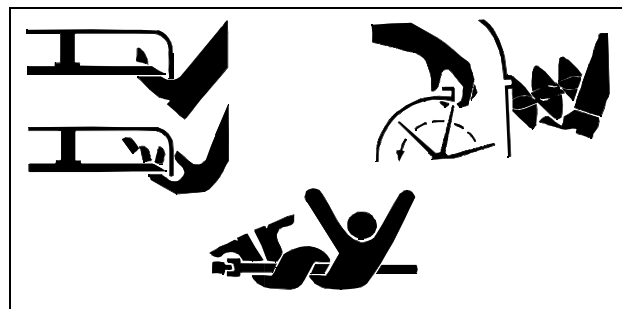

MIF

Keep hands and feet away while machine is running. Shut off power to service, lubricate or remove mower blades, augers or PTO shafts.

# SAFETY

## Service Cooling System Safety

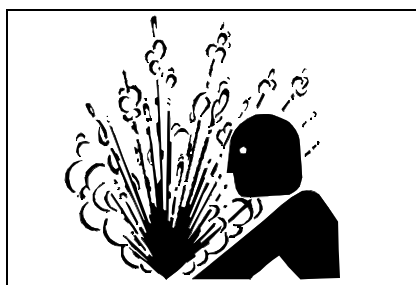

MIF

Explosive release of fluids from pressurized cooling system can cause serious burns.

Shut off machine. Only remove filler cap when cool enough to touch with bare hands. Slowly loosen cap to first stop to relieve pressure before removing completely.

## Handle Chemical Products Safely

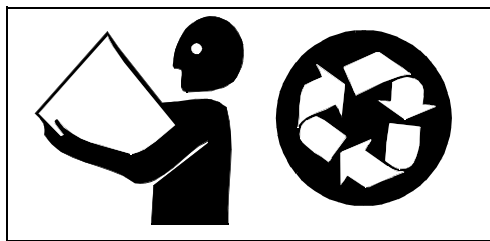

MIF

Direct exposure to hazardous chemicals can cause serious injury. Potentially hazardous chemicals used with John Deere equipment include such items as lubricants, coolants, paints, and adhesives.

A Material Safety Data Sheet (MSDS) provides specific details on chemical products: physical and health hazards, safety procedures, and emergency response techniques. Check the MSDS before you start any job using a hazardous chemical. That way you will know exactly what the risks are and how to do the job safely. Then follow procedures and recommended equipment.

## Dispose of Waste Properly

Improperly disposing of waste can threaten the environment and ecology. Potentially harmful waste used with John Deere equipment include such items as oil, fuel, coolant, brake fluid, filters, and batteries. Use leakproof containers when draining fluids. Do not use food or beverage containers that may mislead someone into drinking from them. Do not pour waste onto the ground, down a drain, or into any water source. Inquire on the proper way to recycle or dispose of waste from your local environmental or recycling center, or from your John Deere dealer.

## Park Machine Safely

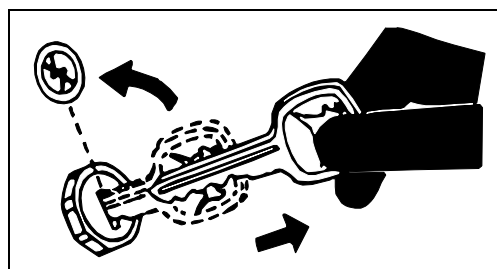

MIF

### Before working on the machine:

1. Lower all equipment to the ground.
2. Stop the engine and remove the key.
3. Lock the park brake.
4. Disconnect the battery ground strap.
5. Hang a "DO NOT OPERATE" tag in operator station.

## Live With Safety



MIF

Before returning machine to customer, make sure machine is functioning properly, especially the safety systems. Install all guards and shields.

# SPECIFICATIONS AND INFORMATION TABLE OF CONTENTS

---

---

## Table of Contents

<b>General Information</b> .....	<b>7</b>
Metric Fastener Torque Values .....	7
Inch Fastener Torque Values .....	8
Face Seal Fittings with Inch Stud Ends Torque .....	9
Face Seal Fittings with Metric Stud Ends Torque .....	10
O-Ring Face Seal Fittings .....	11
O-Ring Boss Fittings .....	11
Diesel Fuel .....	12
Diesel Fuel Lubricity .....	12
Diesel Fuel Storage.....	12
4 - Cycle Diesel Engine Oil.....	12
Break-In Engine Oil - Diesel .....	13
Transaxle Oil .....	13
EMFWD Differential Oil .....	13
Alternative Lubricants.....	14
Synthetic Lubricants .....	14
Lubricant Storage .....	14
Mixing of Lubricants .....	14
Oil Filters .....	14
Brake Fluid .....	14
Chassis Grease .....	14
<b>Coolant</b> .....	<b>15</b>
Recommended Engine Coolant .....	15
<b>Serial Number Locations</b> .....	<b>15</b>
Product Serial Number .....	15

# SPECIFICATIONS AND INFORMATION GENERAL INFORMATION

## General Information

## Metric Fastener Torque Values

Property Class and Head Markings				
Property Class and Nut Markings				

MIF (TS1163)

SIZE	Class 4.8				Class 8.8 or 9.8				Class 10.9				Class 12.9			
	Lubricated <sup>1</sup>		Dry <sup>a</sup>		Lubricated <sup>a</sup>		Dry <sup>a</sup>		Lubricated <sup>a</sup>		Dry <sup>a</sup>		Lubricated <sup>a</sup>		Dry <sup>a</sup>	
	N•m	lb-ft	N•m	lb-ft	N•m	lb-ft	N•m	lb-ft	N•m	lb-ft	N•m	lb-ft	N•m	lb-ft	N•m	lb-ft
M6	4.8	3.5	6	4.5	9	6.5	11	8.5	13	9.5	17	12	15	11.5	19	14.5
M8	12	8.5	15	11	22	16	28	20	32	24	40	30	37	28	47	35
M10	23	17	29	21	43	32	55	40	63	47	80	60	75	55	95	70
M12	40	29	50	37	75	55	95	70	110	80	140	105	130	95	165	120
M14	63	47	80	60	120	88	150	110	175	130	225	165	205	150	260	109
M16	100	73	125	92	190	140	240	175	275	200	350	225	320	240	400	300
M18	135	100	175	125	260	195	330	250	375	275	475	350	440	325	560	410
M20	190	140	240	180	375	275	475	350	530	400	675	500	625	460	800	580
M22	260	190	330	250	510	375	650	475	725	540	925	675	850	625	1075	800
M24	330	250	425	310	650	475	825	600	925	675	1150	850	1075	800	1350	1000
M27	490	360	625	450	950	700	1200	875	1350	1000	1700	1250	1600	1150	2000	1500
M30	675	490	850	625	1300	950	1650	1200	1850	1350	2300	1700	2150	1600	2700	2000
M33	900	675	1150	850	1750	1300	2200	1650	2500	1850	3150	2350	2900	2150	3700	2750
M36	1150	850	1450	1075	2250	1650	2850	2100	3200	2350	4050	3000	3750	2750	4750	3500

<sup>1</sup> "Lubricated" means coated with a lubricant such as engine oil, or fasteners with phosphate and oil coatings. "Dry" means plain or zinc plated (yellow dichromate - Specification JDS117) without any lubrication.

DO NOT use these hand torque values if a different torque value or tightening procedure is given for a specific application. Torque values listed are for general use only and include a ±10% variance factor. Check tightness of fasteners periodically. DO NOT use air powered wrenches.

Shear bolts are designed to fail under predetermined loads. Always replace shear bolts with identical grade.

Fasteners should be replaced with the same class. Make sure fastener threads are clean and that you properly start

thread engagement. This will prevent them from failing when tightening.







When bolt and nut combination fasteners are used, torque values should be applied to the NUT instead of the bolt head.

Tighten toothed or serrated-type lock nuts to the full torque value.

Reference: JDS-G200.

# SPECIFICATIONS AND INFORMATION GENERAL INFORMATION

## Inch Fastener Torque Values

SAE Grade and Head Markings	1 or 2 <sup>1</sup> No Marks 	5    5.1    5.2 	8    8.2 
SAE Grade and Nut Markings	2 No Marks 	5 	8 

MIF (TS1162)

SIZE	Grade 1				Grade 2 <sup>1</sup>				Grade 5, 5.1 or 5.2				Grade 8 or 8.2			
	Lubricated <sup>2</sup>		Dry <sup>2</sup>		Lubricated <sup>2</sup>		Dry <sup>2</sup>		Lubricated <sup>2</sup>		Dry <sup>2</sup>		Lubricated <sup>2</sup>		Dry <sup>2</sup>	
	N•m	lb-ft	N•m	lb-ft	N•m	lb-ft	N•m	lb-ft	N•m	lb-ft	N•m	lb-ft	N•m	lb-ft	N•m	lb-ft
1/4	3.7	2.8	4.7	3.5	6	4.5	7.5	5.5	9.5	7	12	9	13.5	10	17	12.5
5/16	7.7	5.5	10	7	12	9	15	11	20	15	25	18	28	21	35	26
3/8	14	10	17	13	22	16	27	20	35	26	44	33	50	36	63	46
7/16	22	16	28	20	35	26	44	32	55	41	70	52	80	58	100	75
1/2	33	25	42	31	53	39	67	50	85	63	110	80	120	90	150	115
9/16	48	36	60	45	75	56	95	70	125	90	155	115	175	130	225	160
5/8	67	50	85	62	105	78	135	100	170	125	215	160	215	160	300	225
3/4	120	87	150	110	190	140	240	175	300	225	375	280	425	310	550	400
7/8	190	140	240	175	190	140	240	175	490	360	625	450	700	500	875	650
1	290	210	360	270	290	210	360	270	725	540	925	675	1050	750	1300	975
1-1/8	470	300	510	375	470	300	510	375	900	675	1150	850	1450	1075	1850	1350
1-1/4	570	425	725	530	570	425	725	530	1300	950	1650	1200	2050	1500	2600	1950
1-3/8	750	550	950	700	750	550	950	700	1700	1250	2150	1550	2700	2000	3400	2550
1-1/2	1000	725	1250	925	990	725	1250	930	2250	1650	2850	2100	3600	2650	4550	3350

1. "Grade 2" applies for hex cap screws (not hex bolts) up to 152 mm (6 in.) long. "Grade 1" applies for hex cap screws over 152 mm (6 in.) long, and for all other types of bolts and screws of any length.

2. "Lubricated" means coated with a lubricant such as engine oil, or fasteners with phosphate and oil coatings. "Dry" means plain or zinc plated (yellow dichromate - Specification JDS117) without any lubrication.

DO NOT use these hand torque values if a different torque value or tightening procedure is given for a specific application. Torque values listed are for general use only and include a ±10% variance factor. Check tightness of fasteners periodically. DO NOT use air powered wrenches.

Shear bolts are designed to fail under predetermined loads. Always replace shear bolts with identical grade.

Fasteners should be replaced with the same grade. Make sure fastener threads are clean and that you properly start

thread engagement. This will prevent them from failing when tightening.

When bolt and nut combination fasteners are used, torque values should be applied to the NUT instead of the bolt head.

Tighten toothed or serrated-type locknuts to the full torque value.

Reference: JDS-G200.

# SPECIFICATIONS AND INFORMATION GENERAL INFORMATION

## Face Seal Fittings with Inch Stud Ends Torque

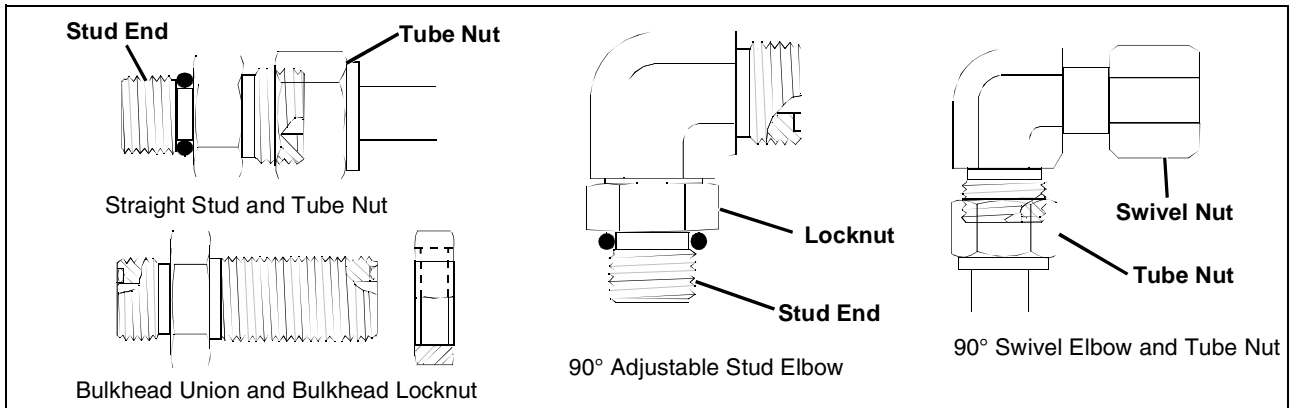

MIF

Nominal Tube OD/Hose ID				Face Seal Tube/Hose End					O-Ring Stud Ends		
Metric Tube OD	Inch Tube OD			Thread Size	Tube Nut/ Swivel Nut Torque		Bulkhead Locknut Torque		Thread Size	Straight Fitting or Locknut Torque	
	mm	Dash Size	in.		mm	in.	N•m	lb-ft		N•m	lb-ft
	-3	0.188	4.76						3/8-24	8	6
6	-4	0.250	6.35	9/16-18	16	12	12	9	7/16-20	12	9
8	-5	0.312	7.94						1/2-20	16	12
10	-6	0.375	9.52	11/16-16	24	18	24	18	9/16-18	24	18
12	-8	0.500	12.70	13/16-16	50	37	46	34	3/4-16	46	34
16	-10	0.625	15.88	1-14	69	51	62	46	7/8-14	62	46
	-12	0.750	19.05	1-3/16-12	102	75	102	75	1-1/16-12	102	75
22	-14	0.875	22.22	1-3/16-12	102	75	102	75	1-3/16-12	122	90
25	-16	1.000	25.40	1-7/16-12	142	105	142	105	1-5/16-12	142	105
32	-20	1.25	31.75	1-11/16-12	190	140	190	140	1-5/8-12	190	140
38	-24	1.50	38.10	2-12	217	160	217	160	1-7/8-12	217	160

**Note: Torque tolerance is +15%, -20%.**

# SPECIFICATIONS AND INFORMATION GENERAL INFORMATION

## Face Seal Fittings with Metric Stud Ends Torque

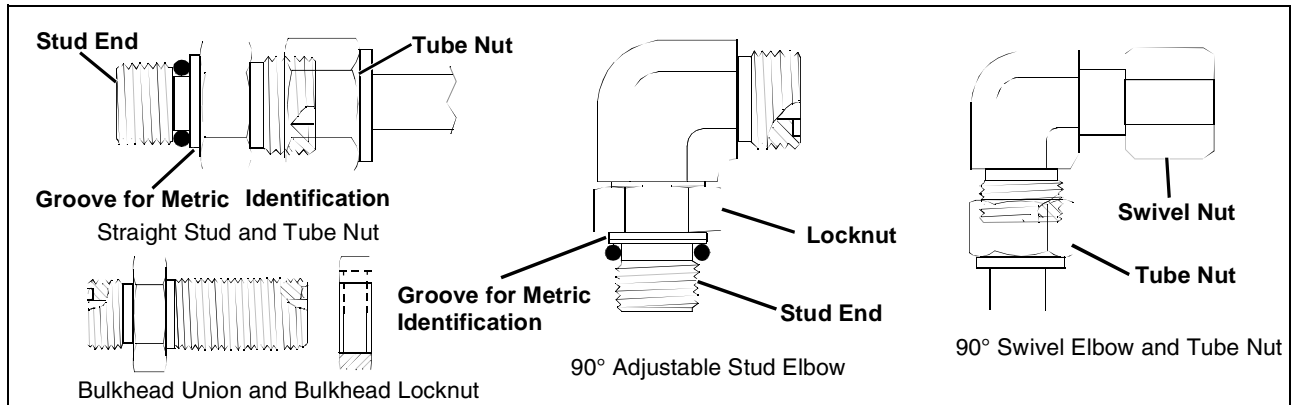

MIF

Nominal Tube OD/Hose ID				Face Seal Tube/Hose End						O-Ring Stud Ends, Straight Fitting or Locknut					
Metric Tube OD	Inch Tube OD			Thread Size	Hex Size	Tube Nut/ Swivel Nut Torque		Bulkhead Locknut Torque		Thread Size	Hex Size	Steel or Gray Iron Torque		Aluminum Torque	
	mm	Dash Size	in.			mm	in.	mm	N•m			lb-ft	N•m	lb-ft	mm
6	-4	0.250	6.35	9/16-18	17	16	12	12	9	M12x1.5	17	21	15.5	9	6.6
8	-5	0.312	7.94							M14x1.5	19	33	24	15	11
10	-6	0.375	9.52	11/16-16	22	24	18	24	18	M16x1.5	22	41	30	18	13
12	-8	0.500	12.70	13/16-16	24	50	37	46	34	M18x1.5	24	50	37	21	15
16	-10	0.625	15.88	1-14	30	69	51	62	46	M22x1.5	27	69	51	28	21
	-12	0.750	19.05	1-3/16-12	36	102	75	102	75	M27x2	32	102	75	46	34
22	-14	0.875	22.22	1-3/16-12	36	102	75	102	75	M30x2	36				
25	-16	1.000	25.40	1-7/16-12	41	142	105	142	105	M33x2	41	158	116	71	52
28										M38x2	46	176	130	79	58
32	-20	1.25	31.75	1-11/16-12	50	190	140	190	140	M42x2	50	190	140	85	63
38	-24	1.50	38.10	2-12	60	217	160	217	160	M48x2	55	217	160	98	72

**Note: Torque tolerance is +15%, -20%.**

# SPECIFICATIONS AND INFORMATION GENERAL INFORMATION

## O-Ring Face Seal Fittings

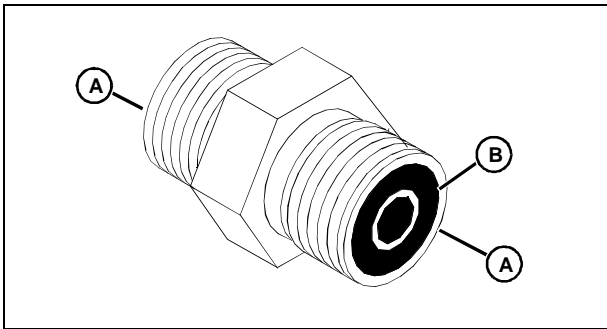

MIF

1. Inspect the fitting sealing surfaces (A). They must be free of dirt or defects.
2. Inspect the O-ring (B). It must be free of damage or defects.
3. Lubricate O-rings and install into groove using petroleum jelly to hold in place.
4. Push O-ring into the groove with plenty of petroleum jelly so O-ring is not displaced during assembly.
5. Index angle fittings and tighten by hand-pressing joint together to ensure O-ring remains in place.

**Important: Avoid Damage! DO NOT allow hoses to twist when tightening fittings. Use two wrenches to tighten hose connections: one to hold the hose, and the other to tighten the swivel fitting.**

6. Tighten fitting or nut to torque value shown on the chart per dash size stamped on the fitting.

## O-Ring Boss Fittings

1. Inspect O-ring boss seat. It must be free of dirt and defects. If repeated leaks occur, inspect for defects with a magnifying glass. Some raised defects can be removed with a slip stone.

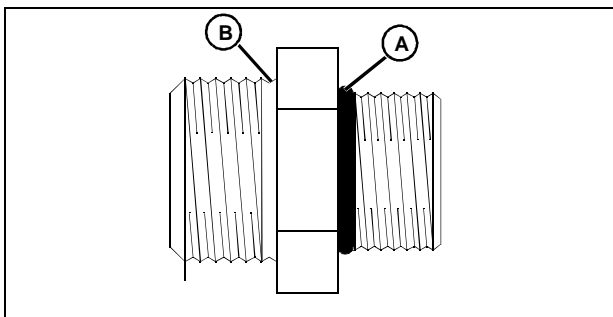

MIF

2. Put hydraulic oil or petroleum jelly on the O-ring (A). Place electrical tape over the threads to protect O-ring from nicks. Slide O-ring over the tape and into the groove (B) of fitting. Remove tape.

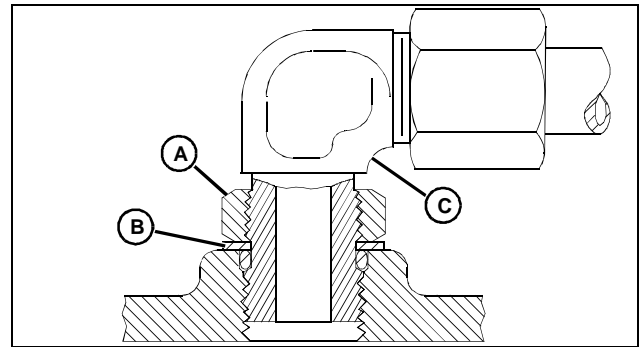

MIF

3. For angle fittings, loosen special nut (A) and push special washer (B) against threads so O-ring can be installed into the groove of fitting.
4. Turn fitting into the boss by hand until special washer or washer face (straight fitting) contacts boss face and O-ring is squeezed into its seat.
5. To position angle fittings (C), turn the fitting counter-clockwise a maximum of one turn.
6. Tighten straight fittings to torque value shown on chart. For angle fittings, tighten the special nut to value shown on the chart while holding body of fitting with a wrench.

Thread Size	Torque <sup>1</sup>		Number of Flats <sup>2</sup>
	N•m	lb-ft	
3/8-24 UNF	8	6	2
7/16-20 UNF	12	9	2
1/2-20 UNF	16	12	2
9/16-18 UNF	24	18	2
3/4-16 UNF	46	34	2
7/8-14 UNF	62	46	1-1/2
1-1/16-12 UN	102	75	1
1-3/16-12 UN	122	90	1
1-5/16-12 UN	142	105	3/4
1-5/8-12 UN	190	140	3/4
1-7/8-12 UN	217	160	1/2

1. Torque tolerance is  $\pm 10$  percent.

2. To be used if a torque wrench cannot be used. After tightening fitting by hand, put a mark on nut or boss, then tighten special nut or straight fitting the number of flats shown.

# SPECIFICATIONS AND INFORMATION GENERAL INFORMATION

## Diesel Fuel



**Caution: Avoid Injury! California Proposition 65 Warning: Diesel engine exhaust and some of its elements from this product are known to the State of California to cause cancer, birth defects, or other reproductive harm.**

In general, diesel fuels are blended to satisfy the low air temperature requirements of the geographical area in which they are sold.

In North America, diesel fuel is usually specified to **ASTM D975** and sold as either **Grade 1** for cold air temperatures or **Grade 2** for warm air temperatures.

If diesel fuels being supplied in your area **DO NOT** meet any of the above specifications, use diesel fuels with the following equivalent properties:

- **Cetane Number 40 (minimum)**

A cetane number **greater than 50 is preferred**, especially for air temperatures below -20°C (-4°F) or elevations above 1500 m (5000 ft).

- **Cold Filter Plugging Point (CFPP)**

The air temperature at which diesel fuel **begins to cloud or jell** - at least 5°C (9°F) below the expected low air temperature range.

- **Sulfur Content of 0.05% (maximum)**

Diesel fuels for highway use in the United States now require sulfur content to be **less than 0.05%**.

If diesel fuel being used has a sulfur content **greater than 0.05%**, **reduce the service interval for engine oil and filter by 50%**.

Consult your local diesel fuel distributor for properties of the diesel fuel available in your area.

## Diesel Fuel Lubricity

Diesel fuel must have adequate lubricity to ensure proper operation and durability of fuel injection system components. Fuel lubricity should pass a **minimum of 3300 gram load level** as measured by the **BOCLE** scuffing test.

## Diesel Fuel Storage

**Important: Avoid Damage! DO NOT USE GALVANIZED CONTAINERS** - diesel fuel stored in galvanized containers reacts with zinc coating in the container to form zinc flakes. If fuel contains water, a zinc gel will also form. The gel and flakes will quickly plug fuel filters and damage fuel injectors and fuel pumps.

It is recommended that diesel fuel be stored **ONLY** in a clean, approved **POLYETHYLENE PLASTIC** container **WITHOUT** any metal screen or filter. This will help prevent any accidental sparks from occurring. Store fuel in an area that is well ventilated to prevent possible igniting of fumes by an open flame or spark, this includes any appliance with a pilot light.

**Important: Avoid Damage! Keep all dirt, scale, water or other foreign material out of fuel.**

Keep fuel in a safe, protected area and in a clean, properly marked ("**DIESEL FUEL**") container. **DO NOT** use de-icers to attempt to remove water from fuel. **DO NOT** depend on fuel filters to remove water from fuel. It is recommended that a water separator be installed in the storage tank outlet. **BE SURE** to properly discard unstable or contaminated diesel fuel and/or their containers when necessary.

## 4 - Cycle Diesel Engine Oil

Use the appropriate oil viscosity based on the expected air temperature range during the period between recommended oil changes. Operating outside of these recommended oil air temperature ranges may cause premature engine failure.

The following John Deere oils are **PREFERRED**:

**TORQ-GARD SUPREME™**  
**PLUS-50™**

Other oils may be used if above John Deere oils are not available, provided they meet one of the following specifications:

- API Service Classifications CF - 4 or higher;

**Important: Avoid Damage! If diesel fuel with sulfur content greater than 0.5% is used, reduce the service interval for oil and filter by 50%.**

# SPECIFICATIONS AND INFORMATION GENERAL INFORMATION

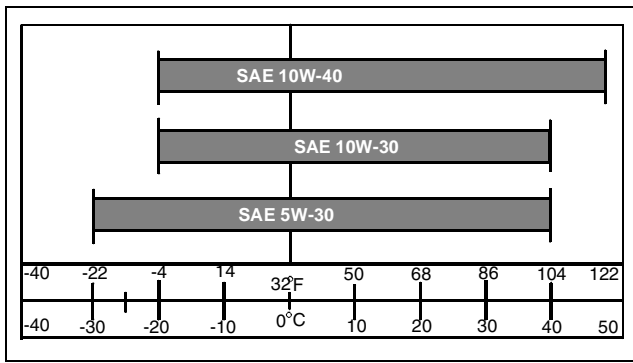

## Break-In Engine Oil - Diesel

**Important: Avoid Damage! ONLY use this specified break-in oil in rebuilt or remanufactured engines for the first 100 hours (maximum) of operation. DO NOT use PLUS - 50®, SAE 15W40 oil or oils meeting specifications API CG - 4 or API CF - 4, these oils will not allow rebuilt or remanufactured engines to break-in properly.**

The following John Deere oil is PREFERRED:

- BREAK - IN ENGINE OIL.**

John Deere BREAK - IN ENGINE OIL is formulated with special additives for aluminum and cast iron type engines to allow the power cylinder components (pistons, rings, and liners as well) to “wear-in” while protecting other engine components, valve train and gears, from abnormal wear. Engine rebuild instructions should be followed closely to determine if special requirements are necessary.

John Deere BREAK - IN ENGINE OIL is also recommended for non-John Deere engines, both aluminum and cast iron types.

If this preferred John Deere oil is not available, use a break-in engine oil meeting the following specification during the first 100 hours of operation:

- API Service Classification CE or higher.

**Important: Avoid Damage! After the break-in period, use the John Deere oil that is recommended for this engine.**

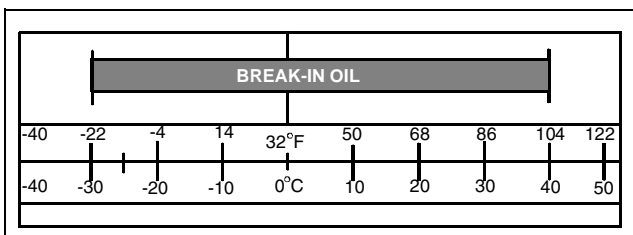

## Transaxle Oil

Use the appropriate oil viscosity based on these air temperature ranges. Operating outside of these recommended oil air temperature ranges may cause premature hydrostatic transmission or hydraulic system failures.

**Important: Avoid Damage! Mixing of LOW VISCOSITY HY - GARD™ and HY - GARD™ oils is permitted. DO NOT mix any other oils in this transmission. DO NOT use engine oil or “Type F” (Red) Automatic Transmission Fluid in this transmission.**

John Deere J20C HY-GARD™ transmission and hydraulic oil is recommended. John Deere J20D Low Viscosity HY-GARD™ transmission and hydraulic oil may be used, if within the specified temperature range.

Other oils may be used if above recommended John Deere oils are not available, provided they meet one of the following specifications:

- John Deere Standard JDM J20C;
- John Deere Standard JDM J20D.

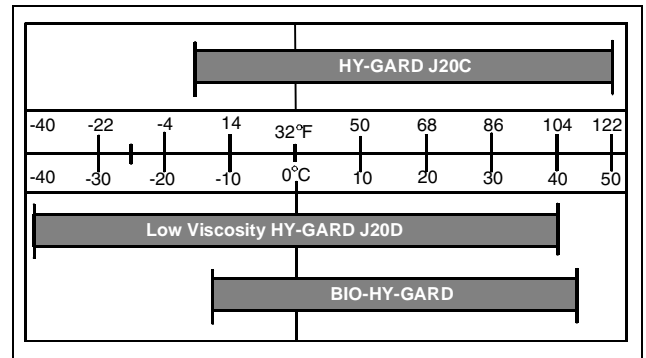

## EMFWD Differential Oil

John Deere J20D Low Viscosity HY-GARD™ transmission and hydraulic oil is recommended.

**Important: Avoid Damage! Mixing of LOW VISCOSITY HY - GARD™ and HY - GARD™ oils is permitted. DO NOT mix any other oils in this transmission. DO NOT use engine oil or “Type F” (Red) Automatic Transmission Fluid in this transmission.**

Other oils may be used if above recommended John Deere oils are not available, provided they meet the following specification:

- John Deere Standard JDM J20D.

# SPECIFICATIONS AND INFORMATION GENERAL INFORMATION

---

## Alternative Lubricants

Use of alternative lubricants could cause reduced life of the component.

If alternative lubricants are to be used, it is recommended that the factory fill be thoroughly removed before switching to any alternative lubricant.

## Synthetic Lubricants

Synthetic lubricants may be used in John Deere equipment if they meet the applicable performance requirements (industry classification and/or military specification) as shown in this manual.

The recommended air temperature limits and service or lubricant change intervals should be maintained as shown in the operator's manual, unless otherwise stated on lubricant label.

Avoid mixing different brands, grades, or types of oil. Oil manufacturers blend additives in their oils to meet certain specifications and performance requirements. Mixing different oils can interfere with the proper functioning of these additives and degrade lubricant performance.

## Lubricant Storage

All machines operate at top efficiency only when clean lubricants are used. Use clean storage containers to handle all lubricants. Store them in an area protected from dust, moisture, and other contamination. Store drums on their sides. Make sure all containers are properly marked as to their contents. Dispose of all old, used containers and their contents properly.

## Mixing of Lubricants

In general, avoid mixing different brands or types of lubricants. Manufacturers blend additives in their lubricants to meet certain specifications and performance requirements. Mixing different lubricants can interfere with the proper functioning of these additives and lubricant properties which will downgrade their intended specified performance.

## Oil Filters

**Important: Avoid Damage! Filtration of oils is critical to proper lubrication performance. Always change filters regularly.**

The following John Deere oil filters are PREFERRED:

- AUTOMOTIVE AND LIGHT TRUCK ENGINE OIL FILTERS.

Most John Deere filters contain pressure relief and anti-

drainback valves for better engine protection.

Other oil filters may be used if above recommended John Deere oil filters are not available, provided they meet the following specification:

- ASTB Tested In Accordance With SAE J806.

## Brake Fluid

**The following John Deere heavy duty brake fluid is PREFERRED for all drum and disc brakes:**

- Brake Fluid - DOT3

Other brake fluids may be used if the above John Deere brake fluid is not available and they provide the following:

- DOT3 certified.
- Conforms to Motor Vehicle Safety Standard No. 116.
- Minimum wet boiling point 140°C (284°F).
- Minimum dry boiling point 232°C (450°F) to prevent vapor lock.

## Chassis Grease

Use the following grease based on the air temperature range. Operating outside of the recommended grease air temperature range may cause premature failures.

The following John Deere grease is PREFERRED:

- Multi-Purpose SD Polyurea Grease
- Multi-Purpose HD Lithium Complex Grease
- **Moly High-Temperature EP Grease**

Other greases may be used if above preferred John Deere grease is not available, provided they meet the following specification:

- John Deere Standard JDM J13E4, NLGI Grade 2.

# SPECIFICATIONS AND INFORMATION COOLANT

## Coolant

### Recommended Engine Coolant

**Important: Avoid Damage! Using incorrect coolant mixture can cause overheating and damage to the radiator and engine:**

- Do not operate engine with plain water.
- Do not exceed a 50% mixture of coolant and water.
- Aluminum engine blocks and radiators require approved ethylene-glycol based coolant.

The engine cooling system is filled to provide year-round protection against corrosion and cylinder liner pitting, and winter freeze protection to -37 degrees C (-34 degrees F). If protection at lower temperatures is required, consult your John Deere dealer for recommendations.

#### The following coolants are preferred:

- John Deere COOL-GARD II Premix
- John Deere COOL-GARD Premix
- John Deere COOL-GARD PG Premix

John Deere COOL-GARD II Premix and John Deere COOL-GARD Premix are available in a concentration of 50% propylene glycol.

John Deere COOL-GARD PG Premix is available in a concentration of 55% propylene glycol.

#### Additional recommended coolants:

- John Deere COOL-GARD II Concentrate in a 40% to 60% mixture of concentrate with water.
- John Deere COOL-GARD Concentrate in a 40% to 60% mixture of concentrate with water.

**If the recommended coolants are unavailable, use an ethylene glycol or propylene glycol base coolant that meets the following specification:**

- ASTM D3306 prediluted (50%) coolant.
- ASTM D3306 coolant concentrate in a 40% to 60% mixture of concentrate with water.

Check container label before using to be sure it has the appropriate specifications for your machine. Use coolant with conditioner or add conditioner to coolant before using.

#### Water Quality

- Water quality is important to the performance of the cooling system. Distilled, deionized, or demineralized water is recommended with ethylene glycol base engine coolant concentrate.

## Serial Number Locations

### Product Serial Number



MX44978

The 13-digit product identification number (A) is located on the right-hand side frame.

Engine serial number (A) is located on the valve cover.

# ENGINE - DIESEL TABLE OF CONTENTS

## Table of Contents

<b>Specifications .....19</b>	Engine Oil Pressure Test..... 50
Engine Specifications.....19	Fuel Injection System Tests..... 51
Operational Tests.....19	Fuel Injection Nozzle Test ..... 52
Tests and Adjustment Specifications .....20	Injection Pump Timing ..... 54
Repair Specifications.....20	Injection Pump Static Timing Check..... 54
Tightening Torques .....24	Fuel System Air Bleeding ..... 56
Special or Essential Tools .....25	Fuel Transfer Pump Flow Test ..... 56
Other Materials.....25	Fuel Transfer Pump Pressure Test..... 57
<b>Component Location.....26</b>	<b>Repair..... 57</b>
Engine Fuel System .....26	Engine Removal and Installation ..... 57
Engine Mounts .....27	Muffler Removal and Installation ..... 61
Fuel System Components .....28	Exhaust Manifold Removal and Installation. 62
Exhaust System Components .....29	Rocker Arm Cover Removal and
Coolant System Components.....30	Installation ..... 62
<b>Theory of Operation .....32</b>	Rocker Arm and Push Rods ..... 64
Cooling System Theory of Operation .....32	Cylinder Head Removal and Installation..... 66
Lubrication System Theory of Operation.....33	Cylinder Head Recondition ..... 67
Fuel System Theory of Operation .....34	Crankshaft Rear Oil Seal..... 72
Air System Theory of Operation .....35	Crankshaft Front Oil Seal ..... 73
<b>Diagnostics .....35</b>	Timing Gear Cover ..... 74
Engine Troubleshooting and Diagnostics.....35	Camshaft End Play Check..... 75
System: Engine Oil.....35	Timing Gear Backlash Check ..... 75
Symptom: Excessive Fuel Consumption.....36	Idle Gear..... 76
Symptom: Incorrect Manifold Pressure .....36	Cam Followers..... 77
Symptom: Low Engine Compression .....36	Camshaft ..... 78
Symptom: Engine Starting Problem .....37	Oil Pan and Strainer ..... 81
Symptom: Engine Operation Poor.....38	Connecting Rod Side Play Check..... 81
Symptom: Coolant Temperature Abnormal..40	Crankshaft End Play Check ..... 82
Symptom: Coolant in Oil or Oil in Coolant...41	Connecting Rod Bearing Clearance Check. 82
System: Diagnostics.....41	Crankshaft Main Bearing Clearance Check. 83
<b>Tests and Adjustments .....43</b>	Connecting Rod Repair ..... 84
Air Restriction Indicator Test .....43	Pistons..... 86
Fast Idle Speed Adjustment .....44	Cylinder Bore..... 90
Slow Idle Adjustment.....44	Crankshaft and Main Bearings ..... 91
Throttle Cable Adjustment.....45	Flywheel Removal and Installation ..... 94
Valve Clearance Adjustment.....46	Flywheel Plate ..... 95
Valve Lift Check .....47	Timing Gear Housing..... 95
Cylinder Compression Test.....47	Oil Pump Removal and Installation..... 96
Water Pump/Alternator Drive Belt	Coolant Temperature Switch ..... 97
Adjustment .....48	Thermostat Removal and Installation ..... 97
Thermostat Test .....49	Water Pump Removal and Installation ..... 98
Radiator Bubble Test.....49	Fuel Filter Removal and Installation ..... 99
Cooling System Pressure Test.....50	Fuel Filter Assembly Removal and
Radiator Cap Pressure Test.....50	Installation..... 100
	Fuel Filter Components ..... 100
	Fuel Transfer Pump ..... 101
	Fuel Injection Nozzle ..... 101
	Fuel Injection Pump ..... 104

## ENGINE - DIESEL TABLE OF CONTENTS

---

Fuel Control and Governor Linkage .....	106
Fuel Shutoff Solenoid Removal and Installation .....	107
Starting Motor Removal and Installation ....	107
Alternator Removal and Installation .....	108

---

---

# ENGINE - DIESEL SPECIFICATIONS

---

---

## Specifications

### Engine Specifications

#### General Specifications:

Make .....	Yanmar
Model .....	3TNV70
Injection Type .....	Indirect
Type .....	4-Cycle Diesel
Number of Cylinders .....	3
Bore .....	70 mm (2.76 in.)
Stroke .....	74 mm (2.91 in.)
Displacement .....	0.854 L (52.11 cu in.)
Firing Order .....	1 - 3 - 2
Direction of Rotation .....	Counterclockwise (viewed from flywheel)
Combustion System .....	Indirect Injection Type
Compression Ratio .....	23.4: 1
Cooling .....	Liquid
Oil Capacity (w/filter) .....	2.6 L (2.75 qt)
Governor .....	Centrifugal
Slow Idle (no-load) .....	1050 ±25 rpm
High Idle (no-load) .....	3700 ±25 rpm

### Operational Tests

#### Specifications:

Cylinder Compression Pressure (@250 RPM Cranking Speed) .....	3432 kPa (498 psi)
(Minimum) .....	2746 kPa (398 psi)
Difference Between Cylinders .....	245 kPa (36 psi)

#### Cooling System:

Coolant Capacity (approximate) .....	5.0 L (5.2 qt)
Radiator Cap Opening Pressure .....	0.9 ± 0.15 kg/cm <sup>2</sup> , 88.3 ± 14.7 kPa, (12.8 ± 2.2 psi)
Cooling System Pressure Test .....	0.9 ± 0.15 kg/cm <sup>2</sup> , 88.3 ± 14.7 kPa, (12.8 ± 2.2 psi)
Thermostat Opening Temperature .....	69.5 - 72.5 °C (157 - 163 °F)
Thermostat Minimum Lift Height above 85 °C (185 °F) .....	8 mm (0.315 in.)

#### Oil Pressure:

Rated Speed .....	290 - 440 kPa (42 - 63 psi)
Slow Idle (Minimum) .....	60 kPa (9 psi)
Oil Pressure Switch Opening Pressure .....	3 - 4 kPa (6 - 9 psi)



**Suggest:**

**If the above button click is invalid.**

**Please download this document**

**first, and then click the above link**

**to download the complete manual.**

**Thank you so much for reading**

# ENGINE - DIESEL SPECIFICATIONS

---

---

## Tests and Adjustment Specifications

### Specifications:

Valve Clearance	0.15 - 0.25 mm (0.006 - 0.010 in.)
Connecting Rod Side Play	0.2 - 0.4 mm (0.008 - 0.016 in.)
Connecting Rod Bearing Clearance	0.02 - 0.05 mm (0.001 - 0.002 in.)
Crankshaft End Play	0.11 - 0.25 mm (0.004 - 0.009 in.)
Crankshaft Main Bearing Clearance	0.02 - 0.05 mm (0.001 - 0.002 in.)
Camshaft End Play	0.05 - 0.15 mm (0.002 - 0.006 in.)
Alternator Drive Belt Deflection (@98 N (22 lb) Applied Force)	10 - 15 mm (0.4 - 0.6 in.)

### Fuel Injection Nozzle:

Opening Pressure	12300 - 13300 kPa (1784 - 1929 psi)
Leakage at 11032 kPa (1600 psi)	None for a minimum of 5 seconds
Chatter and Spray Pattern at 12300 - 13300 kPa (1784 - 1929 psi):	
Slow Hand Lever Movement	Chatter Sound

## Repair Specifications

### Valve Train:

Rocker Arm Shaft OD	11.97 - 11.98 mm (0.471 - 0.472 in.)
Wear Limit	11.94 mm (0.470 in.)
Rocker Arm and Shaft Support Bushings ID	12.00 - 12.02 mm (0.472 - 0.473 in.)
Wear Limit	12.07 mm (0.475 in.)
Oil Clearance	0.02 - 0.05 mm (0.001 - 0.002 in.)
Wear Limit	0.13 mm (0.005 in.)
Push Rod Bend (maximum)	0.0 - 0.03 mm (0.0 - 0.001 in.)

### Cylinder Head:

Cylinder Head Flatness	0.000 - 0.05 mm (0.000 - 0.002 in.)
Service Limit	0.15 mm (0.006 in.)

### Valve Seat Angles:

Exhaust Valve	45°
Intake Valve	30°
Lower Seat Surface	70°
Upper Seat Surface	15°
Intake Valve Head Margin	0.9 - 1.1 mm (0.035 - 0.043 in.)
Exhaust Valve Head Margin	1.0 - 1.2 mm (0.039 - 0.047 in.)
Wear Limit	0.50 mm (0.02 in.)

### Valve Recession:

Intake and Exhaust	0.40 - 0.60 mm (0.016 - 0.024 in.)
Wear Limit Intake	0.9 mm (0.035 in.)
Wear Limit Exhaust	0.8 mm (0.031 in.)

### Valve Stem Diameter:

Intake	5.96 - 5.98 mm (0.234 - 0.235 in.)
Exhaust	5.95 - 5.96 mm (0.234 - 0.235 in.)

**<https://www.ebooklibonline.com>**

Hello dear friend!

Thank you very much for reading.

Enter the link into your browser.

The full manual is available for immediate download.

**<https://www.ebooklibonline.com>**