

9920 and 9930 Cotton Picker

For complete service information also see:

| | |
|---|-------|
| 6359 Engine | CTM4 |
| 6059 Engine | CTM8 |
| Starting Motors and Alternators | CTM77 |
| Radial Piston Pump | CTM7 |

John Deere Des Moines Works
TM1283 (29APR94)

LITHO IN U.S.A.
ENGLISH

INTRODUCTION

FOREWORD

This manual is written for an experienced technician. Essential tools required in performing certain service work are identified in this manual and are recommended for use.

Live with safety: Read the safety messages in the introduction of this manual and the cautions presented throughout the text of the manual.



This is the safety-alert symbol. When you see this symbol on the machine or in this manual, be alert to the potential for personal injury.

Technical manuals are divided in two parts: repair and diagnostics. Repair sections tell how to repair the components. Diagnostic sections help you identify the majority of routine failures quickly.

Information is organized in groups for the various components requiring service instruction. At the beginning of each group are summary listings of all applicable essential tools, service equipment and tools, other materials needed to do the job, service parts kits, specifications, wear tolerances, and torque values.

Binders, binder labels, and tab sets can be ordered by John Deere dealers direct from the John Deere Distribution Service Center.

This manual is part of a total product support program.

FOS MANUALS—REFERENCE

TECHNICAL MANUALS—MACHINE SERVICE

COMPONENT MANUALS—COMPONENT SERVICE

Fundamentals of Service (FOS) Manuals cover basic theory of operation, fundamentals of troubleshooting, general maintenance, and basic type of failures and their causes. FOS Manuals are for training new personnel and for reference by experienced technicians.

Technical Manuals are concise guides for specific machines. Technical manuals are on-the-job guides containing only the vital information needed for diagnosis, analysis, testing, and repair.

Component Technical Manuals are concise service guides for specific components. Component technical manuals are written as stand-alone manuals covering multiple machine applications.

HANDLE FLUIDS SAFELY—AVOID FIRES

When you work around fuel, do not smoke or work near heaters or other fire hazards.

Store flammable fluids away from fire hazards. Do not incinerate or puncture pressurized containers.

Make sure machine is clean of trash, grease, and debris.

Do not store oily rags; they can ignite and burn spontaneously.



DX,FLAME -19-04JUN90

10-05-1
-JUN-23AUG88
TS227

PREVENT BATTERY EXPLOSIONS

Keep sparks, lighted matches, and open flame away from the top of battery. Battery gas can explode.

Never check battery charge by placing a metal object across the posts. Use a volt-meter or hydrometer.

Do not charge a frozen battery; it may explode. Warm battery to 16°C (60°F).



DX,SPARKS -19-03MAR93

-JUN-23AUG88
TS204

PREPARE FOR EMERGENCIES

Be prepared if a fire starts.

Keep a first aid kit and fire extinguisher handy.

Keep emergency numbers for doctors, ambulance service, hospital, and fire department near your telephone.

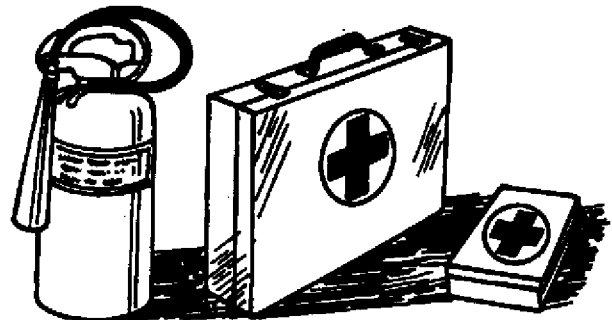

DX,FIRE2 -19-03MAR93

-JUN-23AUG88
TS291

<https://www.ebooklibonline.com>

Hello dear friend!

Thank you very much for reading.

Enter the link into your browser.

The full manual is available for immediate download.

<https://www.ebooklibonline.com>

PREVENT ACID BURNS

Sulfuric acid in battery electrolyte is poisonous. It is strong enough to burn skin, eat holes in clothing, and cause blindness if splashed into eyes.

Avoid the hazard by:

1. Filling batteries in a well-ventilated area.
2. Wearing eye protection and rubber gloves.
3. Avoiding breathing fumes when electrolyte is added.
4. Avoiding spilling or dripping electrolyte.
5. Use proper jump start procedure.

If you spill acid on yourself:

1. Flush your skin with water.
2. Apply baking soda or lime to help neutralize the acid.
3. Flush your eyes with water for 15—30 minutes. Get medical attention immediately.

If acid is swallowed:

1. Do not induce vomiting.
2. Drink large amounts of water or milk, but do not exceed 2 L (2 quarts).
3. Get medical attention immediately.

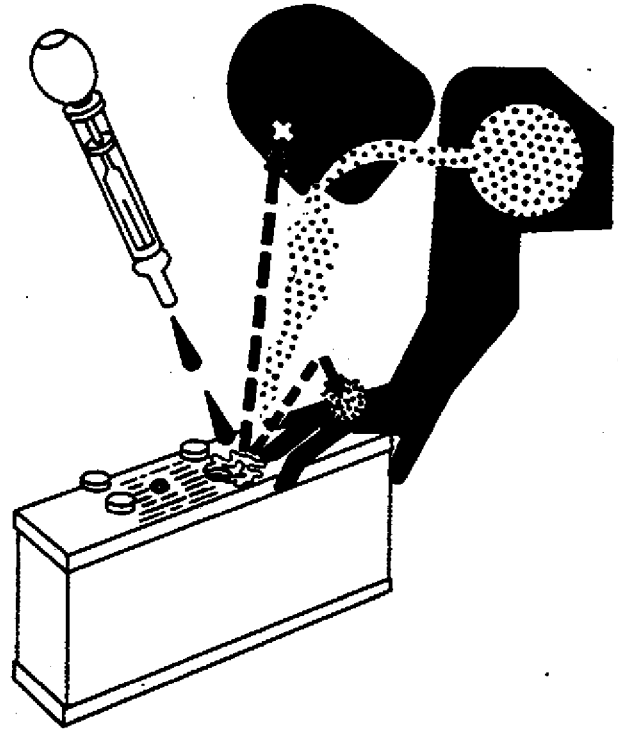

TS203 -JUN-23AUG88

DX,POISON -19-21APR93

HANDLE CHEMICAL PRODUCTS SAFELY

Direct exposure to hazardous chemicals can cause serious injury. Potentially hazardous chemicals used with John Deere equipment include such items as lubricants, coolants, paints, and adhesives.

A Material Safety Data Sheet (MSDS) provides specific details on chemical products: physical and health hazards, safety procedures, and emergency response techniques.

Check the MSDS before you start any job using a hazardous chemical. That way you will know exactly what the risks are and how to do the job safely. Then follow procedures and recommended equipment.

(See your John Deere dealer for MSDS's on chemical products used with John Deere equipment.)

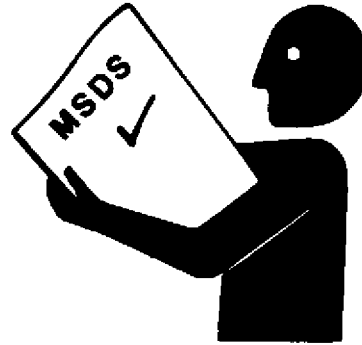

DX,MSDS,NA -19-03MAR93

10
3
5
-JUN-26NOV90
TS1132

AVOID HIGH-PRESSURE FLUIDS

Escaping fluid under pressure can penetrate the skin causing serious injury.

Avoid the hazard by relieving pressure before disconnecting hydraulic or other lines. Tighten all connections before applying pressure.

Search for leaks with a piece of cardboard. Protect hands and body from high pressure fluids.

If an accident occurs, see a doctor immediately. Any fluid injected into the skin must be surgically removed within a few hours or gangrene may result. Doctors unfamiliar with this type of injury should reference a knowledgeable medical source. Such information is available from Deere & Company Medical Department in Moline, Illinois, U.S.A.

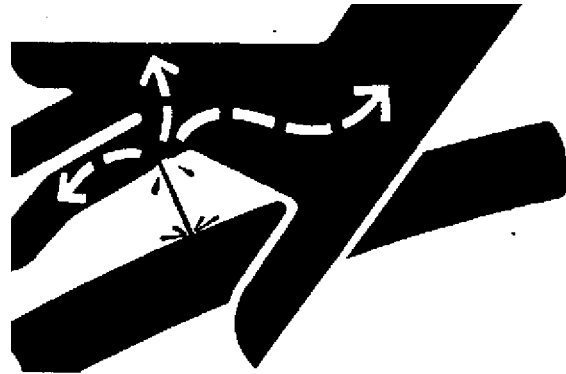

DX,FLUID -19-03MAR93

-JUN-23AUG88
X9811

10
05
4

AVOID CONTACT WITH ENGAGED PICKING UNIT

If service is required with engaged picking units, avoid contact with moving parts. Moving parts can puncture or dismember body parts, or cause death.

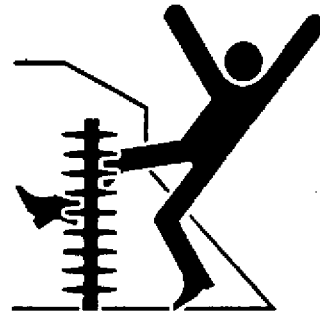

NX,N01,1000K -19-01DEC88

N39613 -JUN-07OCT88

PARK MACHINE SAFELY

Before working on the machine:

- Lower all equipment to the ground.
- Stop the engine and remove the key.
- Disconnect the battery ground strap.
- Hang a "DO NOT OPERATE" tag in operator station.

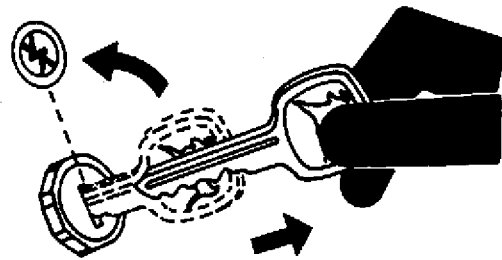

DX,PARK -19-04JUN90

TS230 -JUN-24MAY89

- Look overhead for electric lines or low ceiling.

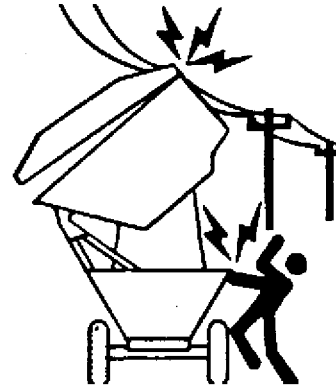

NX,N01,1000,L -19-01DEC88

N39671 -JUN-30NOV88

SUPPORT MACHINE PROPERLY

Always lower the attachment or implement to the ground before you work on the machine. If you must work on a lifted machine or attachment, securely support the machine or attachment.

Do not support the machine on cinder blocks, hollow tiles, or props that may crumble under continuous load. Do not work under a machine that is supported solely by a jack. Follow recommended procedures in this manual.

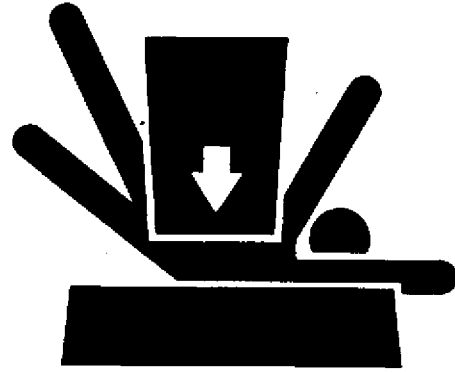

DX,LOWER -19-04JUN90

51910
-JUN-23AUG88
TS229

WEAR PROTECTIVE CLOTHING

Wear close fitting clothing and safety equipment appropriate to the job.

Prolonged exposure to loud noise can cause impairment or loss of hearing.

Wear a suitable hearing protective device such as earmuffs or earplugs to protect against objectionable or uncomfortable loud noises.

Operating equipment safely requires the full attention of the operator. Do not wear radio or music headphones while operating machine.

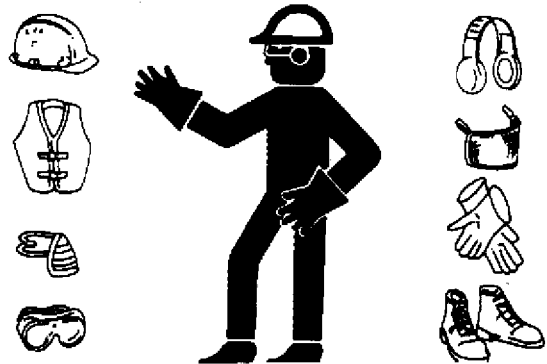

DX,WEAR -19-10SEP90

-JUN-23AUG88
TS206

WORK IN CLEAN AREA

Before starting a job:

- Clean work area and machine.
- Make sure you have all necessary tools to do your job.
- Have the right parts on hand.
- Read all instructions thoroughly; do not attempt shortcuts.

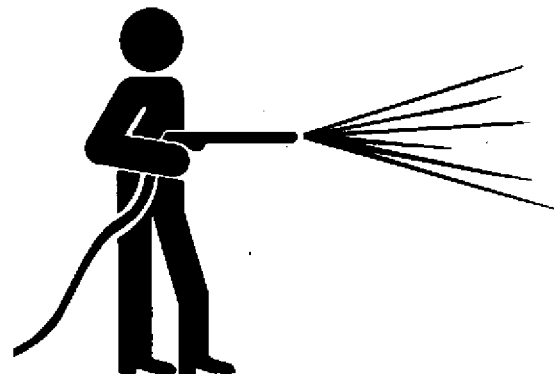

DX,CLEAN -19-04JUN90

-JUN-18OCT88
T6642EJ

SERVICE MACHINES SAFELY

Tie long hair behind your head. Do not wear a necktie, scarf, loose clothing, or necklace when you work near machine tools or moving parts. If these items were to get caught, severe injury could result.

Remove rings and other jewelry to prevent electrical shorts and entanglement in moving parts.

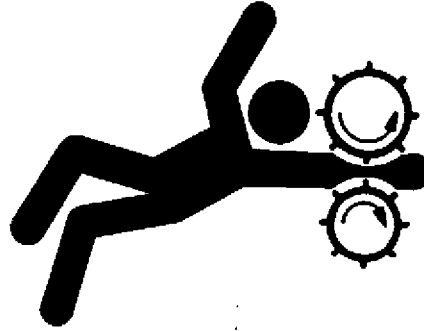

DX, LOOSE -19-04JUN90

TS228 -JUN-23AUG88

WORK IN VENTILATED AREA

Engine exhaust fumes can cause sickness or death. If it is necessary to run an engine in an enclosed area, remove the exhaust fumes from the area with an exhaust pipe extension.

If you do not have an exhaust pipe extension, open the doors and get outside air into the area.

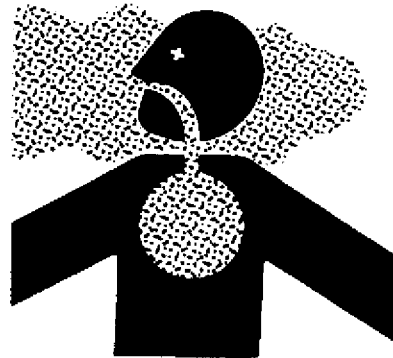

DX, AIR -19-04JUN90

TS220 -JUN-23AUG88

ILLUMINATE WORK AREA SAFELY

Illuminate your work area adequately but safely. Use a portable safety light for working inside or under the machine. Make sure the bulb is enclosed by a wire cage. The hot filament of an accidentally broken bulb can ignite spilled fuel or oil.



DX, LIGHT -19-04JUN90

TS223 -JUN-23AUG88

REPLACE SAFETY SIGNS

Replace missing or damaged safety signs. See the machine operator's manual for correct safety sign placement.

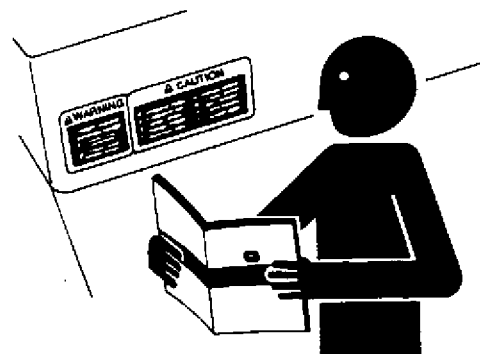

DX, SIGNS1 -19-04JUN90

TS201 -JUN-23AUG88

USE PROPER LIFTING EQUIPMENT

Lifting heavy components incorrectly can cause severe injury or machine damage.

Follow recommended procedure for removal and installation of components in the manual.

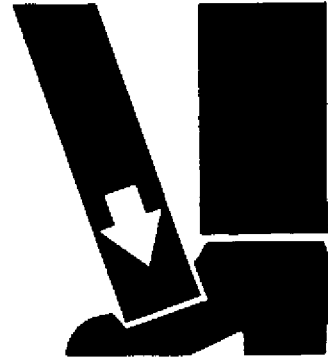

DX,LIFT -19-04JUN90

TS226 -JUN-23AUG88

10
95
7

REMOVE PAINT BEFORE WELDING OR HEATING

Avoid potentially toxic fumes and dust.

Hazardous fumes can be generated when paint is heated by welding, soldering, or using a torch.

Do all work outside or in a well ventilated area. Dispose of paint and solvent properly.

Remove paint before welding or heating:

- If you sand or grind paint, avoid breathing the dust. Wear an approved respirator.
- If you use solvent or paint stripper, remove stripper with soap and water before welding. Remove solvent or paint stripper containers and other flammable material from area. Allow fumes to disperse at least 15 minutes before welding or heating.

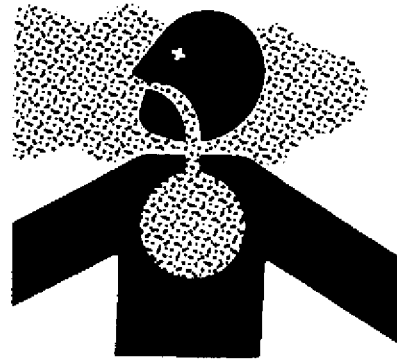

DX,PAINT -19-03MAR93

TS220 -JUN-23AUG88

AVOID HEATING NEAR PRESSURIZED FLUID LINES

Flammable spray can be generated by heating near pressurized fluid lines, resulting in severe burns to yourself and bystanders. Do not heat by welding, soldering, or using a torch near pressurized fluid lines or other flammable materials. Pressurized lines can be accidentally cut when heat goes beyond the immediate flame area.



DX,TORCH -19-03MAR93

TS953 -JUN-15MAY90

10
05
8

SERVICE TIRES SAFELY

Explosive separation of a tire and rim parts can cause serious injury or death.

Do not attempt to mount a tire unless you have the proper equipment and experience to perform the job.

Always maintain the correct tire pressure. Do not inflate the tires above the recommended pressure. Never weld or heat a wheel and tire assembly. The heat can cause an increase in air pressure resulting in a tire explosion. Welding can structurally weaken or deform the wheel.

When inflating tires, use a clip-on chuck and extension hose long enough to allow you to stand to one side and NOT in front of or over the tire assembly. Use a safety cage if available.

Check wheels for low pressure, cuts, bubbles, damaged rims or missing lug bolts and nuts.

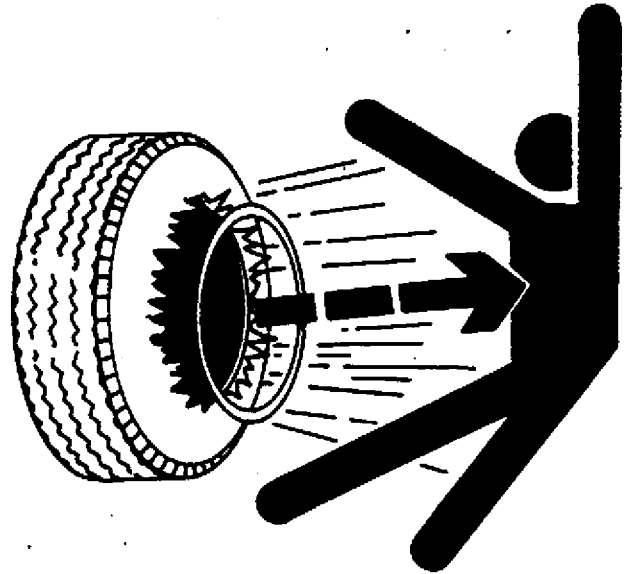

-JUN-23AUG88

TS211

DX,RIM -19-24AUG90

AVOID HARMFUL ASBESTOS DUST

Avoid breathing dust that may be generated when handling components containing asbestos fibers. Inhaled asbestos fibers may cause lung cancer.

Components in products that may contain asbestos fibers are brake pads, brake band and lining assemblies, clutch plates, and some gaskets. The asbestos used in these components is usually found in a resin or sealed in some way. Normal handling is not hazardous as long as airborne dust containing asbestos is not generated.

Avoid creating dust. Never use compressed air for cleaning. Avoid brushing or grinding material containing asbestos. When servicing, wear an approved respirator. A special vacuum cleaner is recommended to clean asbestos. If not available, apply a mist of oil or water on the material containing asbestos.

Keep bystanders away from the area.

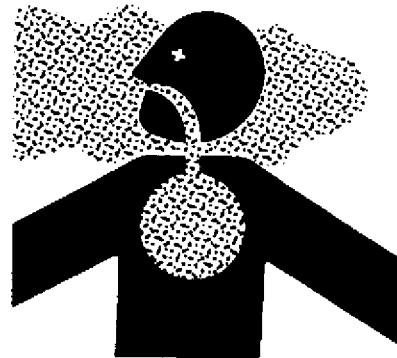

-JUN-23AUG88

TS220

DX,DUST -19-15MAR91

PRACTICE SAFE MAINTENANCE

Understand service procedure before doing work. Keep area clean and dry.

Never lubricate, service, or adjust machine while it is moving. Keep hands, feet, and clothing from power-driven parts. Disengage all power and operate controls to relieve pressure. Lower equipment to the ground. Stop the engine. Remove the key. Allow machine to cool.

Securely support any machine elements that must be raised for service work.

Keep all parts in good condition and properly installed. Fix damage immediately. Replace worn or broken parts. Remove any buildup of grease, oil, or debris.

Disconnect battery ground cable (-) before making adjustments on electrical systems or welding on machine.



-JUN-23AUG88

TS218

DX,SERV -19-03MAR93

USE PROPER TOOLS

Use tools appropriate to the work. Makeshift tools and procedures can create safety hazards.

Use power tools only to loosen threaded parts and fasteners.

For loosening and tightening hardware, use the correct size tools. DO NOT use U.S. measurement tools on metric fasteners. Avoid bodily injury caused by slipping wrenches.

Use only service parts meeting John Deere specifications.



-JUN-08NOV89

TS779

DX,REPAIR -19-04JUN90

10
05
10

DISPOSE OF WASTE PROPERLY

Improperly disposing of waste can threaten the environment and ecology. Potentially harmful waste used with John Deere equipment include such items as oil, fuel, coolant, brake fluid, filters, and batteries.

Use leakproof containers when draining fluids. Do not use food or beverage containers that may mislead someone into drinking from them.

Do not pour waste onto the ground, down a drain, or into any water source.

Air conditioning refrigerants escaping into the air can damage the Earth's atmosphere. Government regulations may require a certified air conditioning service center to recover and recycle used air conditioning refrigerants.

Inquire on the proper way to recycle or dispose of waste from your local environmental or recycling center, or from your John Deere dealer.

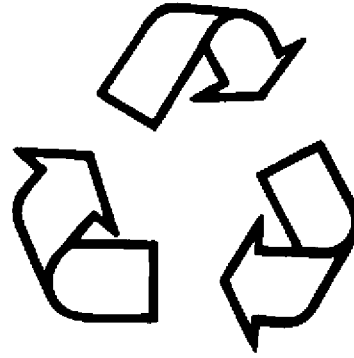

TS1133 -JUN-26NOV90

DX,DRAIN -19-03MAR93

LIVE WITH SAFETY

Before returning machine to customer, make sure machine is functioning properly, especially the safety systems. Install all guards and shields.



TS231 -19-07OCT88

DX,LIVE -19-25SEP92

9920 SPECIFICATIONS

ROW WIDTHS 914, 965, or 1016 mm (36, 38 or 40 inch)

PICKING UNITS

Number of units 2
 Number of picking drums 4
 Number of picker bars (per unit)
 Front drum 12
 Rear drum 12
 Number of spindles (per machine)
 Low drum (14 per bar) 672
 High drum (20 per bar) 960

PICKING UNIT SPEEDS

Picking unit drive shaft 0—1150 rpm*
 Picking drum 0—145 rpm*
 Doffer shaft 0—1755 rpm*
 Spindle 0—4020 rpm*

GROUND SPEEDS (FULL THROTTLE)

Forward
 1st gear 0—5.14 km/h (0—3.2 mph)
 2nd gear 0—6.05 km/h (0—3.8 mph)
 3rd gear 0—20.3 km/h (0—12.6 mph)
 4th gear 0—23.9 km/h (0—14.9 mph)

Reverse
 1st gear 0—2.6 km/h (0—1.6 mph)
 2nd gear 0—3.1 km/h (0—1.9 mph)
 3rd gear 0—10.1 km/h (0—6.3 mph)
 4th gear 0—12 km/h (0—7.45 mph)

CAPACITIES

Cotton basket 17.2 m³ (608 cu. ft)
 Fuel tank 261 L (69 U.S. gal)
 Water tank 553 L (146 U.S. gal)
 Cooling system 30.3 L (32 U.S. qt)
 Thermostat (each) two, 82°C (180°F)
 Engine crankcase, including filter 11.4 L (12 U.S. qt)
 Hydraulic system, including filter 19.9 L (21 U.S. qt)
 Hydraulic reservoir 17.4 L (18.4 U.S. qt)
 Transmission 22.7 L (24 U.S. qt)
 Hydrostatic drive 25.6 L (27 U.S. qt)
 Hydrostatic reservoir 17.4 L (18.4 U.S. qt)

* Speeds listed are theoretical maximums. Actual speeds will be approximately 5 percent lower due to slippage of hydrostatic transmission and drive belts.

10
10
2

TIRES

Front drive wheels 16.9 x 34 8PR (R1, R3) or 18.4 x 30 8PR (R2)
Rear guide wheel 11.00 x 16 8PR

TIRE INFLATION PRESSURE

Drive wheels 210 kPa (30 psi)
Guide wheels 252 kPa (36 psi)

HYDROSTATIC DRIVE

Make
Pump Eaton
Motor Eaton
Type of oil filter Full flow suction
Type of oil cooler Air-cooled

WEIGHT

Low drum 5811 kg (12,800 lb)
High drum 6084 kg (13,400 lb)

ELECTRICAL SYSTEM

Battery voltage 12-volt
Battery terminal grounded Negative
Battery
Group 31
Amps 625
Capacity (min.) 160
Alternator (S.N. 101-380) 72 Amp
(S.N. 381-) 90 Amp

ENGINE

Manufacturer John Deere
Model 6359 DN-01, Diesel
Number of cylinders 6
Bore 106.5 mm (4.19 in.)
Stroke 110 mm (4.33 in.)
Displacement 5883 cm³ (359 cu in.)
Horsepower 85 kW (114 hp)
Engine speeds
Fast idle (no load) 2640—2680 rpm
Rated (under field load) 2500 rpm
Slow idle 780—820 rpm
Muffler Aspirated

NX,N01,1005,AW -19-05FEB87

OPERATOR'S CAB

| | |
|--------------------------------|--|
| Type | Pressurized with heater, SOUND-GARD® (without ROPS) PERSONAL-POSTURE™ seat/deluxe suspension, windshield wiper, and rear view mirror |
| Optional attachment | Air conditioner |
| Windshield wiper | |
| Blade length | 508 mm (20 in.) |
| Arm length | 508 mm (20 in.) |
| Heater Capacity | 5274 W (18,000 BTU) |
| Air conditioner | |
| Compressor make (S.N. 101-380) | Delco |
| (S.N. 381-) | Nippondenso |
| Capacity | 6446 W (22,000 BTU) |
| Refrigerant | R-12 |
| Refrigerant charge | Approx. 2 kg (4-1/2 lb) |

NX,N01,1005,AX -19-05FEB87

10
10
3

10
10
4

9930 SPECIFICATIONS

PICKING UNITS

| | |
|-----------------------------------|--|
| Number of units | 2 |
| Number of picking drums | 4 |
| Number of picker bars (per unit) | |
| Front drum | 12 |
| Rear drum | 12 |
| Number of spindles (per machine) | |
| Low drum (14 per bar) | 672 |
| High drum (20 per bar) | 960 |
| Row spacings | |
| Solid planting | 914, 965, or 1016 mm (36, 38, or 40-in.) |
| Skip row | 813 mm (32-in.) |

PICKING UNIT SPEEDS (P.I.N. -10000)

| | |
|------------------------------------|-------------|
| Picking unit drive shaft | 0—1130 rpm* |
| Picking drum | 0—152 rpm* |
| Doffer shaft | 0—1728 rpm* |
| Spindle | 0—3885 rpm* |

PICKING UNIT SPEEDS (P.I.N. 10001-)

| | |
|------------------------------------|-------------|
| Picking unit drive shaft | 0—1138 rpm* |
| Picking drum | 0—152 rpm* |
| Doffer shaft | 0—1930 rpm* |
| Spindle | 0—3915 rpm* |

GROUND SPEEDS (FULL THROTTLE)

Forward

| | |
|--------------------|--------------------------|
| 1st gear | 0—5.63 km/h (0—3.5 mph) |
| 2nd gear | 0—6.60 km/h (0—4.1 mph) |
| 3rd gear | 0—22.2 km/h (0—13.8 mph) |
| 4th gear | 0—26.2 km/h (0—16.3 mph) |

Reverse

| | |
|--------------------|--------------------------|
| 1st gear | 0—2.9 km/h (0—1.8 mph) |
| 2nd gear | 0—3.4 km/h (0—2.1 mph) |
| 3rd gear | 0—11.1 km/h (0—6.9 mph) |
| 4th gear | 0—13.1 km/h (0—8.15 mph) |

* Speeds listed are theoretical maximums. Actual speeds will be approximately 5 percent lower due to slippage of hydrostatic transmission and drive belts.

NX1283,1005.A -19-09JUN93

CAPACITIES

| | |
|-----------------------------------|---------------------------------|
| Cotton basket | |
| Standard | 17.2 m ³ (608 cu ft) |
| With 356 mm [14 in.] extension | 20.4 m ³ (727 cu ft) |
| Fuel tank | 261 L (69 U.S. gal) |
| Water/solution tank | 643 L (170 U.S. gal) |
| Lubrication reservoir | 227 L (60 U.S. gal) |
| Cooling system | 32.2 L (34 U.S. qt) |
| Engine crankcase, includes filter | 18.9 L (20.0 U.S. qt) |
| Hydraulic system, includes filter | 19.9 L (21 U.S. qt) |
| Hydraulic reservoir | 17.4 L (18.4 U.S. qt) |
| Transmission | 23.6 L (25 U.S. qt) |
| Hydrostatic drive | 25.6 L (27 U.S. qt) |
| Hydraulic reservoir | 17.4 L (18.4 U.S. qt) |
| Final drive (each) | 1.9 L (2 U.S. qt) |

TIRES

| | |
|--|----------------------------|
| Drive wheels | |
| Cleat, 16.9 x 34 10PR (R1) | 221 kPa (2.0 bar) (32 psi) |
| Cane and Rice, 18.4 x 30 10PR (R2) | 207 kPa (2.0 bar) (30 psi) |
| Low Profile, 16.9 x 34 10PR (R3) (P.I.N. -12000) | 221 kPa (2.1 bar) (32 psi) |
| Single Guide Wheel, Rib, 11.00 x 16 8PR (F2M) | 248 kPa (2.5 bar) (36 psi) |
| Dual Guide Wheels, Rib, 7.50 x 24 6PR (I1) | 303 kPa (3.0 bar) (44 psi) |

HYDROSTATIC DRIVE

| | |
|--------------------|--|
| Make | SUNDSTRAND |
| Type of oil filter | Full flow suction |
| Type of oil cooler | Air-cooled |
| Type of oil | John Deere HY-GARD® Hydraulic and Transmission Fluid |

WEIGHT

| | |
|--|---------------------|
| Low drum | |
| Standard | 6345 kg (13,975 lb) |
| With 356 mm [14 in.] extension and vane dump control less tire ballast | 7091 kg (15,620 lb) |
| High drum | |
| Standard | 6617 kg (14,575 lb) |
| With 356 mm [14 in.] extension and vane dump control less tire ballast | 7364 kg (16,220 lb) |

FINAL DRIVE

| | |
|------|----------------------|
| Type | Pinion and ring gear |
|------|----------------------|

ELECTRICAL SYSTEM

| | |
|--------------------------------|----------|
| Battery voltage | 12-volt |
| Battery terminal grounded | Negative |
| Battery | |
| Group | 31 |
| Amps (P.I.N -14000) | 625 |
| (P.I.N. 14001-) | 925 |
| Capacity (min.) (P.I.N -14000) | 160 |
| (P.I.N. 14001-) | 180 |
| Alternator (P.I.N. -12000) | 90 Amp |
| (P.I.N. 12001-) | 95 Amp |

10
10
6

ENGINE

| | |
|--------------------------------|-----------------------------------|
| Model (P.I.N. -2480) | 6359TN02 Diesel |
| (P.I.N. 2481-6000) | 6359TN002, Diesel |
| (P.I.N. 6001-) | 6059TN002, Diesel |
| Number of cylinders | 6 |
| Bore | 106.5 mm (4.19 in.) |
| Stroke | 110 mm (4.33 in.) |
| Displacement | 5883 cm ³ (359 cu in.) |
| Horsepower | 101 kW (135 hp) |
| Engine speeds | |
| Fast idle (no load) | 2675—2725 rpm |
| Rated (under field load) | 2500 rpm |
| Slow idle | 800—900 rpm |
| Compression ratio | 17.4 to 1 |

OPERATOR'S CAB

| | |
|----------------------------------|--|
| Type | SOUND-GARD® styled cab (with no ROPS) PERSONAL-POSTURE™ seat/deluxe suspension, heater, windshield wiper, and rear view mirror |
| Optional attachment | Air conditioner |
| Heater Capacity | 5274 W (18,000 BTU) |
| Air conditioner | |
| Compressor make | Nippondenso |
| Capacity | 6446 W (22,000 BTU) |
| Refrigerant | |
| 9920; 9930 (P.I.N. -14000) | R-12 |
| 9930 (P.I.N. 14001-) | R134a |
| Refrigerant charge | |
| 9920; 9930 (P.I.N. -14000) | 2 kg (4-1/2 lb) |
| 9930 (P.I.N. 14001-) | 1.7 kg (3-3/4 lb) |

NX1283,1005,C -19-10MAR94

METRIC BOLT AND CAP SCREW TORQUE VALUES

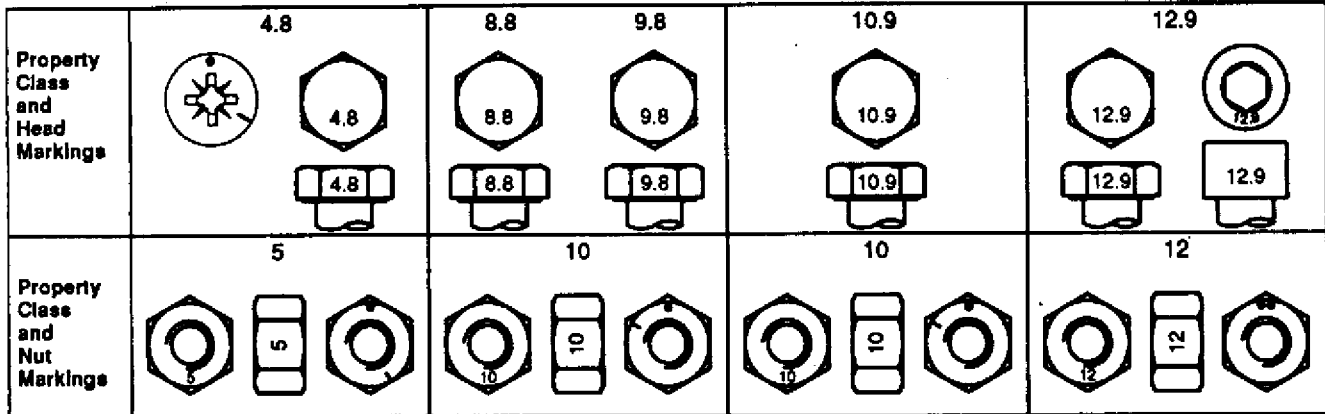

| Size | Class 4.8 | | | | Class 8.8 or 9.8 | | | | Class 10.9 | | | | Class 12.9 | | | |
|------|-------------------------|-------|------------------|-------|-------------------------|-------|------------------|-------|-------------------------|-------|------------------|-------|-------------------------|-------|------------------|-------|
| | Lubricated ^a | | Dry ^a | | Lubricated ^a | | Dry ^a | | Lubricated ^a | | Dry ^a | | Lubricated ^a | | Dry ^a | |
| | N-m | lb-ft | N-m | lb-ft | N-m | lb-ft | N-m | lb-ft | N-m | lb-ft | N-m | lb-ft | N-m | lb-ft | N-m | lb-ft |
| M6 | 4.8 | 3.5 | 6 | 4.5 | 9 | 6.5 | 11 | 8.5 | 13 | 9.5 | 17 | 12 | 15 | 11.5 | 19 | 14.5 |
| M8 | 12 | 8.5 | 15 | 11 | 22 | 16 | 28 | 20 | 32 | 24 | 40 | 30 | 37 | 28 | 47 | 35 |
| M10 | 23 | 17 | 29 | 21 | 43 | 32 | 55 | 40 | 63 | 47 | 80 | 60 | 75 | 55 | 95 | 70 |
| M12 | 40 | 29 | 50 | 37 | 75 | 55 | 95 | 70 | 110 | 80 | 140 | 105 | 130 | 95 | 165 | 120 |
| M14 | 63 | 47 | 80 | 60 | 120 | 88 | 150 | 110 | 175 | 130 | 225 | 165 | 205 | 150 | 260 | 190 |
| M16 | 100 | 73 | 125 | 92 | 190 | 140 | 240 | 175 | 275 | 200 | 350 | 225 | 320 | 240 | 400 | 300 |
| M18 | 135 | 100 | 175 | 125 | 260 | 195 | 330 | 250 | 375 | 275 | 475 | 350 | 440 | 325 | 560 | 410 |
| M20 | 190 | 140 | 240 | 180 | 375 | 275 | 475 | 350 | 530 | 400 | 675 | 500 | 625 | 460 | 800 | 580 |
| M22 | 260 | 190 | 330 | 250 | 510 | 375 | 650 | 475 | 725 | 540 | 925 | 675 | 850 | 625 | 1075 | 800 |
| M24 | 330 | 250 | 425 | 310 | 650 | 475 | 825 | 600 | 925 | 675 | 1150 | 850 | 1075 | 800 | 1350 | 1000 |
| M27 | 490 | 360 | 625 | 450 | 950 | 700 | 1200 | 875 | 1350 | 1000 | 1700 | 1250 | 1600 | 1150 | 2000 | 1500 |
| M30 | 675 | 490 | 850 | 625 | 1300 | 950 | 1650 | 1200 | 1850 | 1350 | 2300 | 1700 | 2150 | 1600 | 2700 | 2000 |
| M33 | 900 | 675 | 1150 | 850 | 1750 | 1300 | 2200 | 1650 | 2500 | 1850 | 3150 | 2350 | 2900 | 2150 | 3700 | 2750 |
| M36 | 1150 | 850 | 1450 | 1075 | 2250 | 1650 | 2850 | 2100 | 3200 | 2350 | 4050 | 3000 | 3750 | 2750 | 4750 | 3500 |

DO NOT use these values if a different torque value or tightening procedure is given for a specific application. Torque values listed are for general use only. Check tightness of fasteners periodically.

Shear bolts are designed to fail under predetermined loads. Always replace shear bolts with identical property class.

Fasteners should be replaced with the same or higher property class. If higher property class fasteners are used, these should only be tightened to the strength of the original.

^a "Lubricated" means coated with a lubricant such as engine oil, or fasteners with phosphate and oil coatings. "Dry" means plain or zinc plated without any lubrication.

Make sure fasteners threads are clean and that you properly start thread engagement. This will prevent them from failing when tightening.

Tighten plastic insert or crimped steel-type lock nuts to approximately 50 percent of the dry torque shown in the chart, applied to the nut, not to the bolt head. Tighten toothed or serrated-type lock nuts to the full torque value.

10
10
7
TS1163 -19-04MAR91

UNIFIED INCH BOLT AND CAP SCREW TORQUE VALUES

10
10
8

| | | | | | | |
|-----------------------------|---------------------|---|-----|-----|---|-----|
| SAE Grade and Head Markings | 1 or 2 ^b | 5 | 5.1 | 5.2 | 8 | 8.2 |
| | | | | | | |
| SAE Grade and Nut Markings | 2 | 5 | | 8 | | |
| | | | | | | |

TS1162 -19-04/MAR91

| Size | Grade 1 | | | | Grade 2 ^b | | | | Grade 5, 5.1, or 5.2 | | | | Grade 8 or 8.2 | | | |
|-------|-------------------------|-------|------------------|-------|-------------------------|-------|------------------|-------|-------------------------|-------|------------------|-------|-------------------------|-------|------------------|-------|
| | Lubricated ^a | | Dry ^a | | Lubricated ^a | | Dry ^a | | Lubricated ^a | | Dry ^a | | Lubricated ^a | | Dry ^a | |
| | N·m | lb-ft | N·m | lb-ft | N·m | lb-ft | N·m | lb-ft | N·m | lb-ft | N·m | lb-ft | N·m | lb-ft | N·m | lb-ft |
| 1/4 | 3.7 | 2.8 | 4.7 | 3.5 | 6 | 4.5 | 7.5 | 5.5 | 9.5 | 7 | 12 | 9 | 13.5 | 10 | 17 | 12.5 |
| 5/16 | 7.7 | 5.5 | 10 | 7 | 12 | 9 | 15 | 11 | 20 | 15 | 25 | 18 | 28 | 21 | 35 | 26 |
| 3/8 | 14 | 10 | 17 | 13 | 22 | 16 | 27 | 20 | 35 | 26 | 44 | 33 | 50 | 36 | 63 | 46 |
| 7/16 | 22 | 16 | 28 | 20 | 35 | 26 | 44 | 32 | 55 | 41 | 70 | 52 | 80 | 58 | 100 | 75 |
| 1/2 | 33 | 25 | 42 | 31 | 53 | 39 | 67 | 50 | 85 | 63 | 110 | 80 | 120 | 90 | 150 | 115 |
| 9/16 | 48 | 36 | 60 | 45 | 75 | 56 | 95 | 70 | 125 | 90 | 155 | 115 | 175 | 130 | 225 | 160 |
| 5/8 | 67 | 50 | 85 | 62 | 105 | 78 | 135 | 100 | 170 | 125 | 215 | 160 | 215 | 160 | 300 | 225 |
| 3/4 | 120 | 87 | 150 | 110 | 190 | 140 | 240 | 175 | 300 | 225 | 375 | 280 | 425 | 310 | 550 | 400 |
| 7/8 | 190 | 140 | 240 | 175 | 190 | 140 | 240 | 175 | 490 | 360 | 625 | 450 | 700 | 500 | 875 | 650 |
| 1 | 290 | 210 | 360 | 270 | 290 | 210 | 360 | 270 | 725 | 540 | 925 | 675 | 1050 | 750 | 1300 | 975 |
| 1-1/8 | 400 | 300 | 510 | 375 | 400 | 300 | 510 | 375 | 900 | 675 | 1150 | 850 | 1450 | 1075 | 1850 | 1350 |
| 1-1/4 | 570 | 425 | 725 | 530 | 570 | 425 | 725 | 530 | 1300 | 950 | 1650 | 1200 | 2050 | 1500 | 2600 | 1950 |
| 1-3/8 | 750 | 550 | 950 | 700 | 750 | 550 | 950 | 700 | 1700 | 1250 | 2150 | 1550 | 2700 | 2000 | 3400 | 2550 |
| 1-1/2 | 1000 | 725 | 1250 | 925 | 990 | 725 | 1250 | 930 | 2250 | 1650 | 2850 | 2100 | 3600 | 2650 | 4550 | 3350 |

DO NOT use these values if a different torque value or tightening procedure is given for a specific application. Torque values listed are for general use only. Check tightness of fasteners periodically.

Fasteners should be replaced with the same or higher grade. If higher grade fasteners are used, these should only be tightened to the strength of the original.

Shear bolts are designed to fail under predetermined loads. Always replace shear bolts with identical grade.

Make sure fasteners threads are clean and that you properly start thread engagement. This will prevent them from failing when tightening.

Tighten plastic insert or crimped steel-type lock nuts to approximately 50 percent of the dry torque shown in the chart, applied to the nut, not to the bolt head. Tighten toothed or serrated-type lock nuts to the full torque value.

^a "Lubricated" means coated with a lubricant such as engine oil, or fasteners with phosphate and oil coatings. "Dry" means plain or zinc plated without any lubrication.

^b Grade 2 applies for hex cap screws (not hex bolts) up to 152 mm (6-in.) long. Grade 1 applies for hex cap screws over 152 mm (6-in.) long, and for all other types of bolts and screws of any length.

FLAT FACE O-RING SEAL FITTING TORQUE CHART

1. Inspect the fitting sealing surfaces. They must be free of dirt or defects.
2. Inspect the O-ring. It must be free of damage or defects.
3. Lubricate O-rings and install into groove using petroleum jelly to hold in place.
4. Push O-ring into the groove with plenty of petroleum jelly so O-ring is not displaced during assembly.
5. Index angle fittings and tighten by hand pressing joint together to insure O-ring remains in place.
6. Tighten fitting or nut to torque value shown on the chart per dash size stamped on the fitting. Do not allow hoses to twist when tightening fittings.

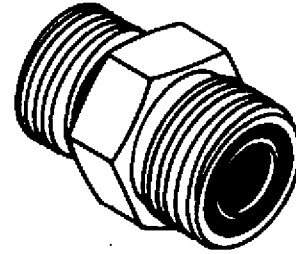

FLAT FACE O-RING SEAL FITTING TORQUE

| Tube mm | Nominal O.D. (in.) | Dash Size | Thread Size in. | Swivel Nut Torque | |
|------------|--------------------------|--------------|-----------------------|----------------------|---------|
| | | | | N-m | (lb-ft) |
| 6.35 | 0.250 | -4 | 9/16-18 | 24 | 18 |
| 9.52 | 0.375 | -6 | 11/16-16 | 30 | 22 |
| 12.70 | 0.500 | -8 | 13/16-16 | 47 | 35 |
| 15.88 | 0.625 | -10 | 1-14 | 75 | 55 |
| 19.05 | 0.750 | -12 | 1 3/16-12 | 114 | 84 |
| 22.22 | 0.875 | -14 | 1 3/16-12 | 114 | 84 |
| 25.40 | 1.000 | -16 | 1 7/16-12 | 155 | 115 |
| 31.75 | 1.250 | -20 | 1 11/16-12 | 193 | 142 |
| 38.10 | 1.500 | -24 | 2-12 | 225 | 166 |

NOTE: Torque tolerance is +15 -20%.

910
-JUN-18OCT88
T6249AD

10
10
10

O-RING BOSS FITTING TORQUE CHART

STRAIGHT FITTING

1. Inspect O-ring boss seat for dirt or defects.
2. Lubricate O-ring with petroleum jelly. Place electrical tape over threads to protect O-ring. Slide O-ring over tape and into O-ring groove of fitting. Remove tape.
3. Tighten fitting to torque value shown on chart.

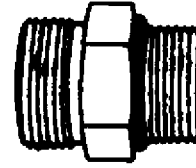

ANGLE FITTING

1. Back-off lock nut (A) and back-up washer (B) completely to head-end (C) of fitting.
2. Turn fitting into threaded boss until back-up washer (B) contacts face of boss.
3. Turn fitting head-end (C) counterclockwise to proper index (maximum of one turn).
4. Hold fitting head-end (C) with a wrench and tighten locknut (A) and back-up washer (B) to proper torque value.

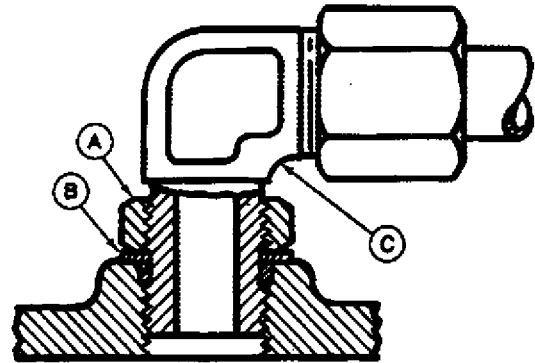

NOTE: Do not allow hoses to twist when tightening fittings.

TORQUE VALUE CHART

| Thread Size | Torque N-m | (lb-ft) |
|--------------|------------|---------|
| 3/8-24 UNF | 8 | (6) |
| 7/16-20 UNF | 12 | (9) |
| 1/2-20 UNF | 16 | (12) |
| 9/16-18 UNF | 24 | (18) |
| 3/4-16 UNF | 46 | (34) |
| 7/8-14 UNF | 62 | (46) |
| 1-1/16-12 UN | 102 | (75) |
| 1-3/16-12 UN | 122 | (90) |
| 1-5/16-12 UN | 142 | (105) |
| 1-5/8-12 UN | 190 | (140) |
| 1-7/8-12 UN | 217 | (160) |

NOTE: Torque tolerance is $\pm 10\%$.

-JUN-18OCT88

T6249AE

-JUN-18OCT88

T6520AB

DIMENSIONS

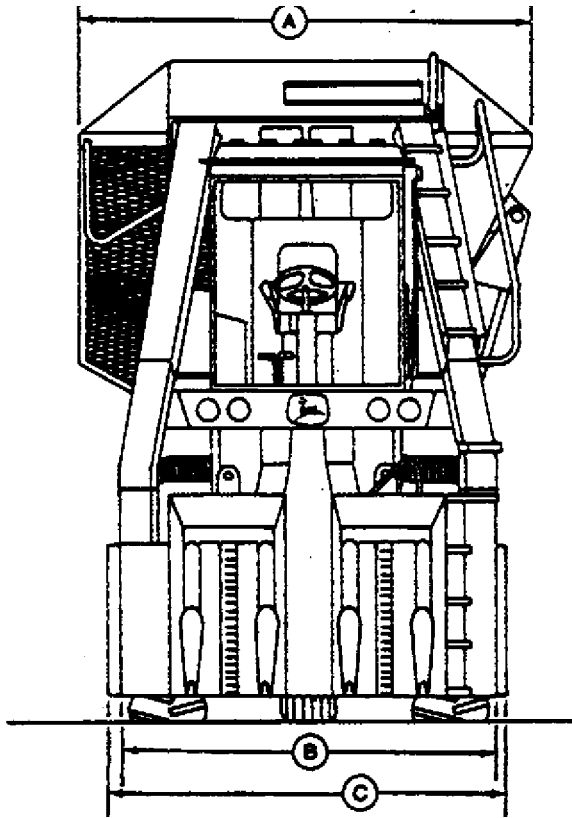

N36962 -JUN-27SEP88

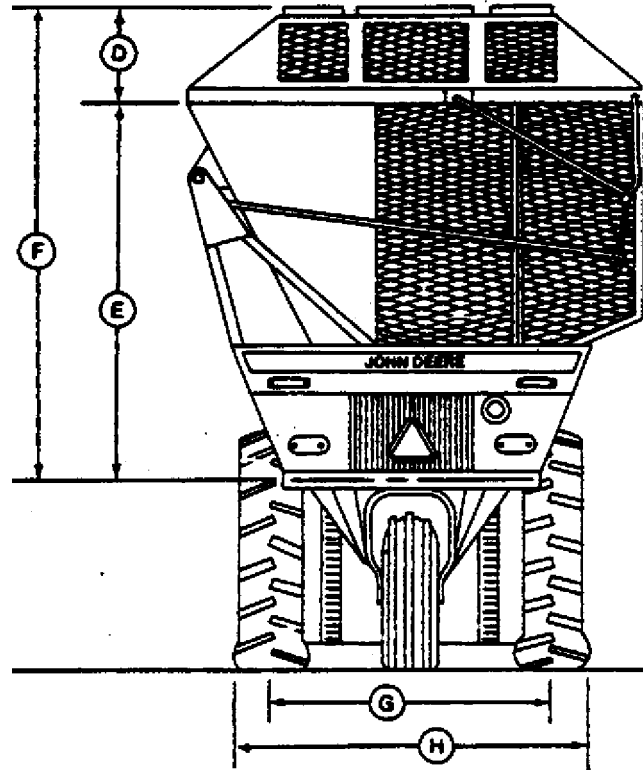

N36963 -JUN-27SEP88

- A—2997 mm (118 in.)
3073 mm (121 in.) (With extension)
- B—Without Wheel Shields
For 914 mm (36 in.) Rows-2337 mm (92 in.)
For 965 mm (38 in.) Rows-2388 mm (94 in.)
For 1016 mm (40 in.) Rows-2438 mm (96 in.)
- C—With Wheel Shields
For 914 mm (36 in.) Rows-2489 mm (98 in.)
For 965 mm (38 in.) Rows-2540 mm (100 in.)
For 1016 mm (40 in.) Rows-2591 mm (102 in.)
- D—584 mm (23 in.)
- E—2403 mm (94-5/8 in.)
- F—2990 mm (117-11/16 in.) (Standard)
3345 mm (131-11/16 in.) With 356 mm (14 in.)
Extension (9930 Only)
- G—2048 mm (80-5/8 in.) R1 or R3 Tires
2067 mm (81-3/8 in.) R2 Tires
- H—2464 mm (97 in.) R1 or R3 Tires
2534 mm (99-3/4 in.) R2 Tires

NX1283,1005,D -19-17SEP93

General Specifications/Dimensions

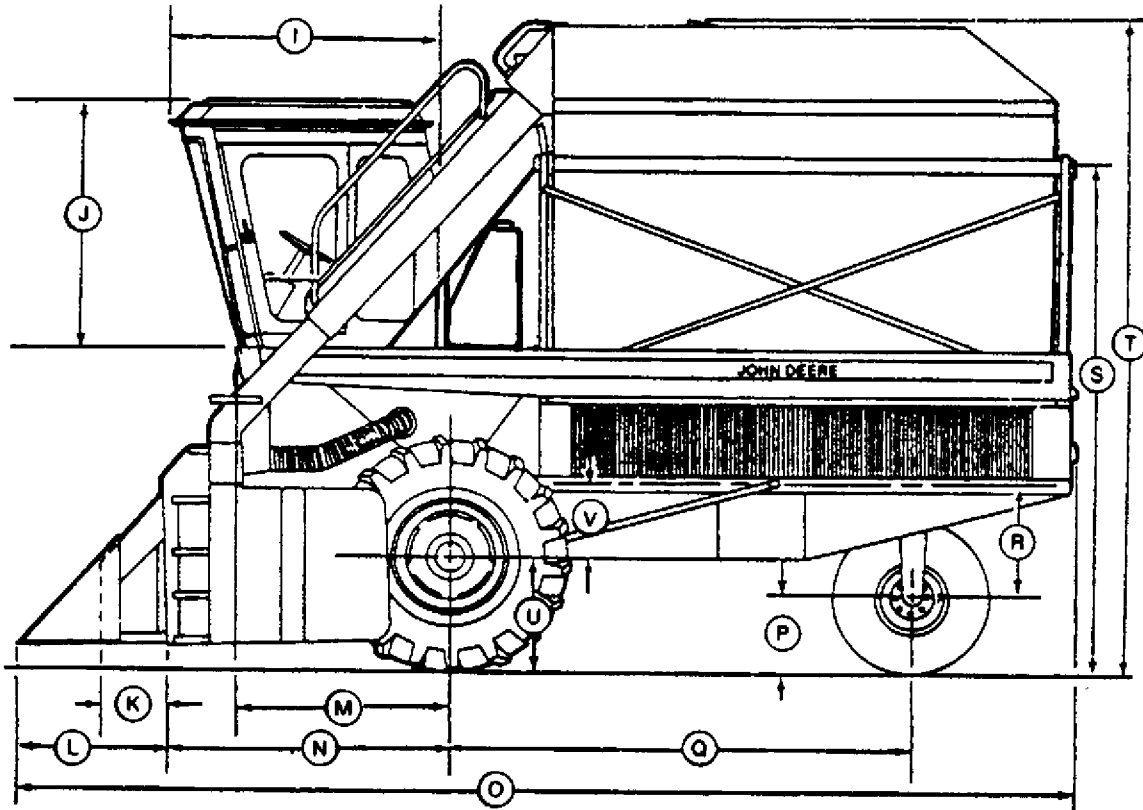

N36964A -JUN-24/FEB92

| | | | |
|----------------------------------|-----------------------------|--|--|
| I—1740 mm (68-1/2 in.) | O—6769 mm (266-1/2 in.) | Q—2972 mm (117 in.) | U—716 mm (28-3/16 in.) (R1 and R3 Tires) |
| J—1638 mm (64-1/2 in.) | High Drum | R—721 mm (28-3/8 in.) | 704 mm (27-11/16 in.) (R2 Tires) |
| K—376 mm (14-13/16 in.) | 6779 mm (266-15/16 in.) | S—3175 mm (125 in.) | V—440 mm (17-5/16 in.) |
| L—935 mm (36-13/16 in.) | Low Drum | T—4128 mm (162-1/2 in.) (Standard) | |
| M—1461 mm (57-1/2 in.) | P—434 mm (17-1/16 in.) | 4483 mm (176-1/2 in.) | |
| N—1921 mm (75-5/8 in.) High Drum | Clearance with Units Raised | With 356 mm (14 in.) Extension (9930 Only) | |
| 1930 mm (76 in.) Low Drum | | | |

(Specifications and design subject to change without notice.)

NX.N01.1005.AZ -19-09MAR92

SERIAL NUMBERS

Use serial numbers in all correspondence with the factory on the following items.

The engine serial number is located on the left-hand side of engine block.



NXN,1005,BW -19-08APR92

103
N86296S1
-JUN-22SEP88

On 9920 Cotton Pickers and 9930 Cotton Pickers, Serial No. 4000 and below, the machine serial number is located above the left-hand drive tire on platform support.



NX,N01,1005,BX -19-05FEB87

N86296AA1
-JUN-22SEP88

On 9930 Cotton Pickers, Serial No. 4001 and above, the machine product identification number (A) is located on left-hand side of the main frame, between the drive tire and guide wheel.



NX,N01,1005,CF -19-01DEC88

N88176A1
-JUN-30NOV88

(9920 Pickers) The EATON hydrostatic motor serial number (A) is located on right-hand side of motor.

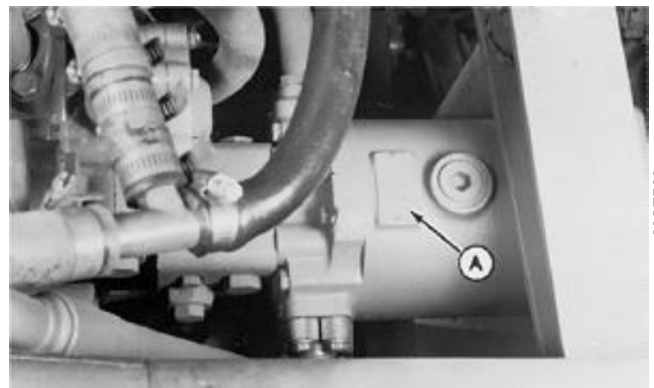

NX,N01,1005,BY -19-24MAR87

N83340T1
-JUN-26SEP88

General Specifications/Serial Numbers

1400

(9930 Pickers) The SUNDSTRAND hydrostatic motor serial number (A) is located on left-hand side of motor.

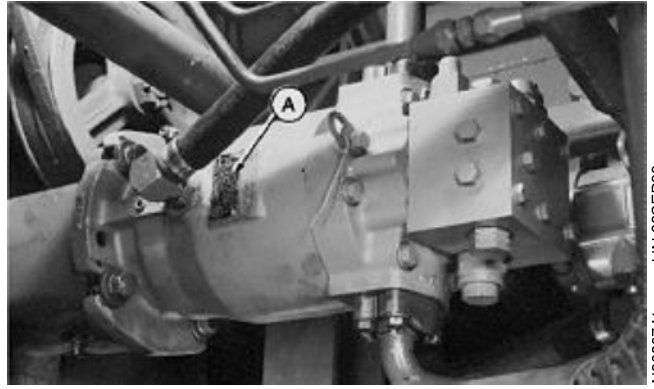

NX,N01,1005,BZ -19-05FEB87

N86297J1 -JUN-22SEP88

(9920 Pickers) The EATON hydrostatic pump serial number (B) is located on bottom of pump.

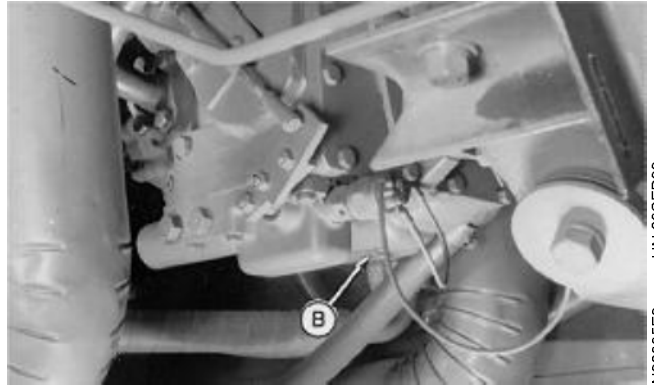

NX,N01,1005,CA -19-05FEB87

N82335E8 -JUN-29SEP88

(9930 Pickers) The SUNDSTRAND hydrostatic pump serial number (A) is located on top of pump.

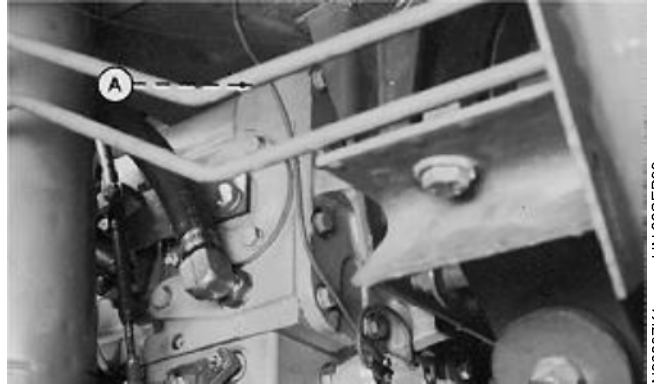

NX,N01,1005,CB -19-05FEB87

N86297K1 -JUN-22SEP88

The cab serial number (A) is on inside left-hand corner of cab.

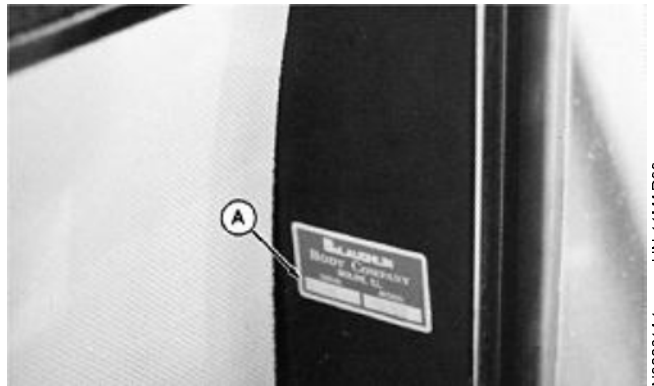

NX1531,1010,H -19-26OCT92

N92261A1 -JUN-11MAR93

General Specifications/Serial Numbers

The picking unit manufacture date (A) is stamped inside each unit front inspection cover, above the front moistener column adjustment screw.

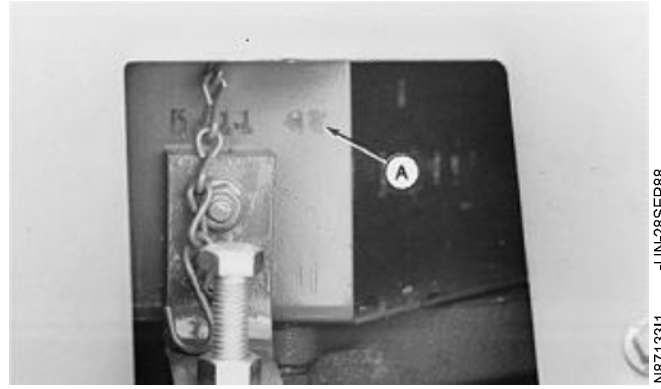

N01,1005,CE -19-06MAR90

1010
-JUN-28-SEP88
N8713311

10
10
16

LUBRICATE MACHINE PROPERLY

IMPORTANT: Correct selection and proper use of lubricating oils and grease is very important in keeping upkeep cost low, while providing long machine life with satisfactory service.

Use only lubricants specified in this section. Lubricate at the intervals listed in the machine's operator's manual.

NX1531,1015,A -19-30MAR92

DIESEL FUEL

Use either Grade No. 1-D or Grade No. 2-D fuel as defined by ASTM Designation D975 for diesel fuels. Find expected air temperature at time of start on thermometer scale in chart. correct diesel fuel grade is shown to the right of scale.

Fuel sulphur content of less than 0.5 percent is preferred, to prevent higher wear from corrosive combustion products.

IMPORTANT: If fuel, sulphur content exceeds 0.7 percent, the engine oil drain interval must be reduced by 50 percent to 100 hours.

Cetane number should be no less than 40 to assure satisfactory starting and overall performance. At low temperatures and/or high altitude, a cetane number of more than 45 is recommended.

Cloud point should be at least 6°C (10°F) below lowest expected air temperature at time of starting. Wax can separate from fuel when temperature decreases to cloud point and may plug filter.

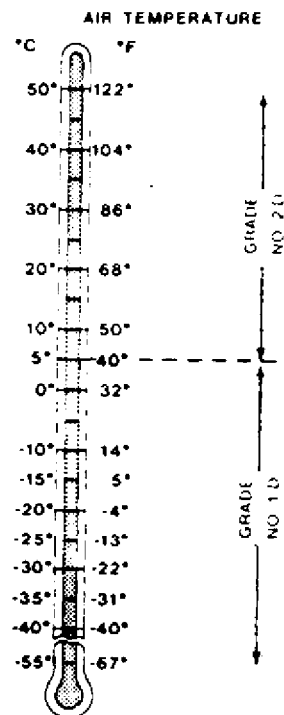

IF YOU OPERATE YOUR EQUIPMENT AT TEMPERATURES BELOW THE LIMITS SHOWN, CONSULT YOUR DEALER FOR SPECIAL LUBRICANTS AND STARTING AIDS.

-19-14FEB89

RW2517

NX,1020,B -19-04MAY90

10
15
2

ENGINE OIL

Use oil viscosity based on the expected air temperature range during the period between oil changes.

The following oil is preferred:

- John Deere TORQ-GARD SUPREME PLUS-50™

The following oils are also recommended:

- John Deere TORQ-GARD SUPREME®
- John Deere UNI-GARD™

Other oils may be used if they meet one or more of the following:

- API Service Classification CE
- API Service Classification CD
- CCMC Specification D5
- CCMC Specification D4

If John Deere TORQ-GARD SUPREME PLUS-50™ engine oil and a John Deere oil filter are used, the oil and filter service interval may be extended by 50 hours.

If diesel fuel with sulfur content greater than 0.5% is used, reduce the service interval for engine oil and filter by 50%.

Arctic oils (such as Military Specification MIL-L-46167B) may be used at temperatures below -30°C (-22°F).

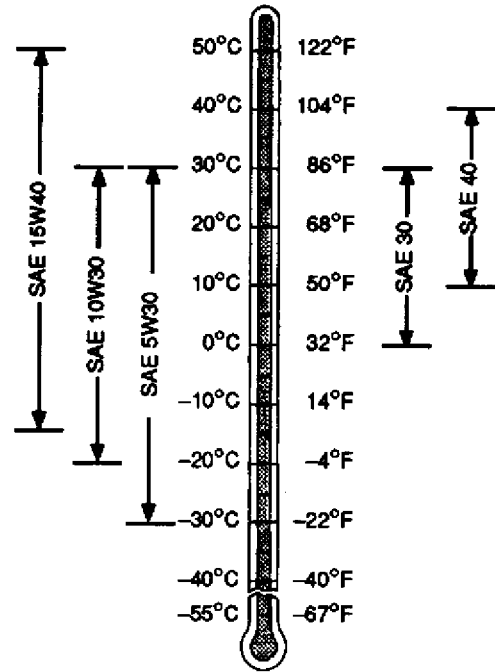

-JUN-31 JAN94

TS1411

HYDRAULIC AND HYDROSTATIC OILS

Depending upon the expected air temperature range during the drain interval, use oil viscosity shown on the adjoining temperature chart.

John Deere HY-GARD® transmission and hydraulic oil is recommended.

NOTE: Factory fill is HY-GARD®.

You may also use QUATROL® oils. These are oils that meet John Deere Standard JDM J20A or J20B.

If other oils are used in the hydrostatic pump and motor they must meet the performance requirements of the following:

- John Deere All-Weather Hydrostatic Fluid
- John Deere Standard JDM J21A
- Automatic transmission fluids meeting:
 - Ford M2C33F specification
 - Ford M2C33G specification
- Quatrol® oils (oils that meet John Deere standards)
- John Deere Standard JDM J20B

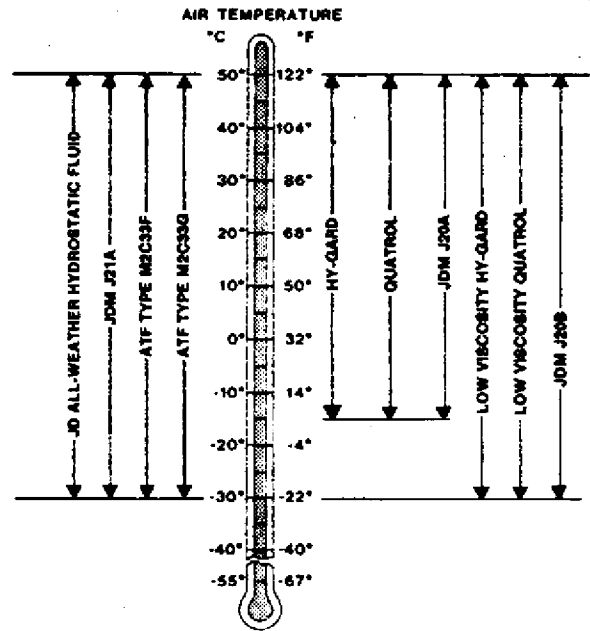

X9320 -19-13JAN89

NX,9960,N3 -19-21FEB90

10
15
4

TRANSMISSION AND FINAL DRIVES

Depending upon the expected air temperature range during the drain interval, use oil viscosity shown on the adjoining temperature chart.

John Deere 85W/140 API GL-5 gear oil is recommended. If other oils are used, they must meet performance requirements of:

- API Service Classification GL-5
- Military Specification MIL-L-2105C

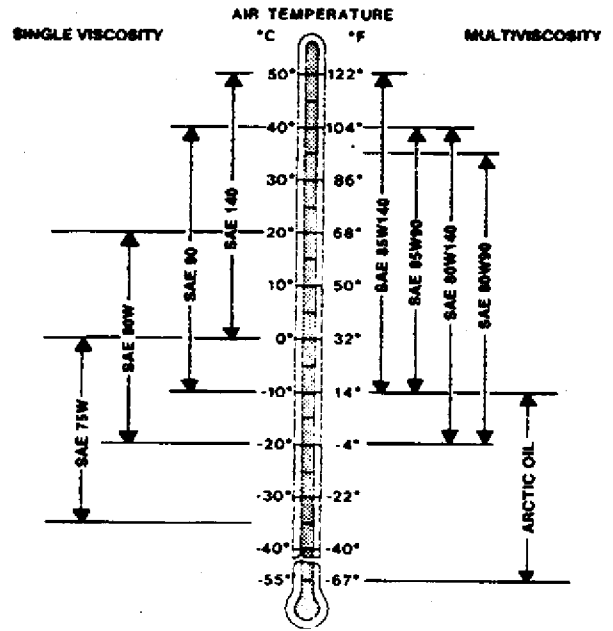

X9322 -19-00SEP88

NX,9960,N4A -19-05MAY94

ENGINE COOLANT

Coolant solutions must meet the following basic requirements:

- Provide for adequate heat transfer.
- Provide a corrosion-resistant environment within the cooling system.
- Prevent formation of scale or sludge deposits in the cooling system.
- Be compatible with cooling system hose and seal materials.
- Provide adequate freeze protection during cold weather operation and boil-over protection in hot weather.

NOTE: In some areas outside the U.S.A., John Deere Engine Cooling Fluid is marketed for use in the engine cooling system. It protects the engine from corrosion and freezing down to -37°C (-35°F).

John Deere Engine Cooling Fluid or John Deere Low Silicate Antifreeze are recommended for all John Deere Diesel Engines. John Deere Cooling Fluid is ready to use as is, without dilution or mixing. John Deere Low Silicate Antifreeze is concentrated and should be mixed 50 percent antifreeze and 50 percent clean, soft water. Consult your John Deere Parts Network for local availability.

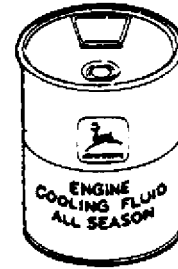

51510
-JUN-07DEC88
RG4831

N01,1015,T -19-12MAR90

61510

To meet these critical requirements, the coolant has to consist of high quality water, the correct antifreeze, and possess adequate inhibitors. Refer to charts, water quality specifications (A) and water quality evaluations (B) when determining coolant requirements.

1. Water Quality

Preferred—Distilled or deionized

Acceptable—Softened to 170 parts per million (10 grains per gallon)

2. Antifreeze

- Must be ethylene glycol type, contain not more than 0.1 percent anhydrous metasilicate, and meet General Motors Performance Specification GM1899M, or be formulated to Specification GM6038M (or equivalent).

NOTE: Some types of ethylene glycol antifreeze commonly available on the open market are intended for automotive use. These products are often labeled for use in aluminum engines and usually contain more than 0.1 percent anhydrous metasilicate. Use of this type antifreeze can cause a gel-like deposit to form that reduces heat transfer and coolant flow. When wet, the gel becomes the same color as the coolant. When dry, it is a white, powdery deposit. Check container label or consult with antifreeze supplier before using.

- Solutions containing 67 percent (maximum) to 50 percent (minimum) antifreeze are recommended.
- Antifreeze solutions should be used year-round for freeze protection, boil-over protection, and stable environment for seals and hoses. Non-use of antifreeze during warm weather is not recommended.
- Do not use methyl alcohol base antifreeze.
- Do not use methoxy propanol antifreeze. Damage can occur to rubber seals on cylinder liners which are in contact with coolant.
- If engine is equipped with a coolant filter/conditioner, do not use an antifreeze containing methoxy propanol or stop leak additive. These products may clog the coolant filter.

| | PARTS PER MILLION | GRAMS PER GALLON |
|----------------------------------|-------------------|------------------|
| Chlorides (Maximum) | 40 | 2.5 |
| Sulfates (Maximum) | 100 | 5.6 |
| Total Dissolved Solids (Maximum) | 340 | 20 |
| Total Hardness (Maximum) | 170 | 10 |

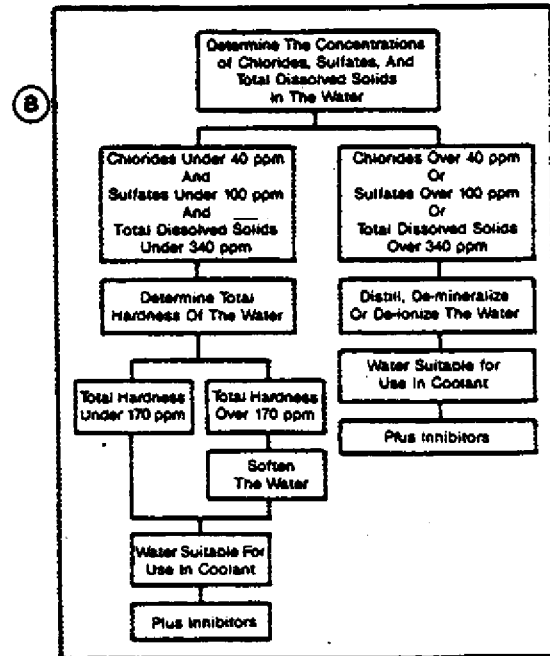

RG5045 -19-28FEB89

3. Inhibitors

- Non-chromate inhibitors must be used.
- Do not use soluble oil.
- Always follow the supplier recommendation's printed on the container. Over-inhibiting antifreeze solutions can cause silicate-dropout. When this happens, a gel-type deposit is created which retards heat transfer and coolant flow.

NOTE: John Deere RE23182 Liquid Coolant Conditioner is a non-chromate inhibitor and is recommended for use in all applications. Follow service recommendation printed on the container.

RE23182 Liquid Coolant Conditioner.

- Guards against rust and corrosion in engine.
- Reduces corrosion of aluminum, solder, cast iron, and steel parts.
- Controls build-up of mineral scale and sludge on heat transfer surfaces.
- Guards against pitting of cylinder liners and water pump impellers.
- Retards foaming of coolant in the system at high and low operating temperatures.
- Counteracts the factors that accelerate inhibitor depletion rates such as high coolant temperatures, high engine loading, or entrainment of air in coolant.

Contact your authorized servicing dealer or engine distributor if there are further questions.



10
15
7
-JUN-14DEC88
RC4690

S55,OMFL,C -19-15FEB88

10
15-8

GREASE

Use grease based on NLGI consistency numbers and the expected air temperature range during the service interval.

The following greases are preferred:

- John Deere MOLY HIGH TEMPERATURE EP GREASE
- John Deere HIGH TEMPERATURE EP GREASE
- John Deere GREASE-GARD™
- John Deere BIO-GREASE-GARD™¹

Other greases may be used if they meet **both** of the following:

- NLGI Performance Classification GC
- NLGI Performance Classification LB

Arctic greases (such as Military Specification MIL-G-10924F) may be used at temperatures below -30°C (-22°F).

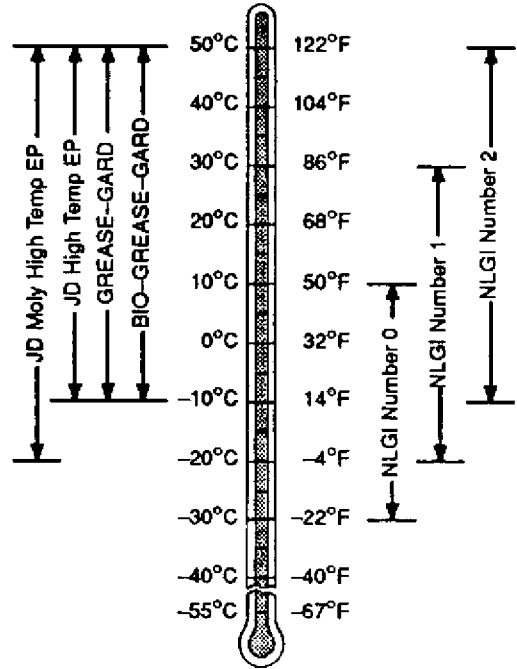

¹BIO-GREASE-GARD meets or exceeds the minimum biodegradability of 80% within 21 days according to CEC-L-33-T-82 test method.

PICKER BAR AND SPINDLE LUBRICANTS

John Deere Spindle Grease is highly recommended and is the only grease that is factory approved for use in John Deere cotton pickers.

Other greases may be used, but they must meet the minimum requirement of JDN360 specification. John Deere Spindle Grease surpasses this minimum specification. It provides the cotton picker with the best protection and gives the best performance, with superior wear characteristics, rust inhibitors, and better start-up at low temperatures.

IMPORTANT: Use of inadequate lubricants can result in high start-up torque, rapid wear, residue build-up, and can cause damage to bearings, bushings, and spindles.



910
-JUN-30NOV88
N39672

NX,1020,C -19-22DEC92

CORN HEAD GREASE

John Deere Corn Head Grease is recommended.

You may also use SAE Multipurpose Grease with Extreme Pressure (EP) Performance and meeting NLGI Consistency Number 0.



N42107AB -JUN-25JAN91

NXN,1283,CORN -19-08APR92

10
15
10

SPECIAL LUBRICANTS (9920 ONLY)

Lubricate the cam track and cam rollers with any of the following lubricants (listed in order of preference).

John Deere Corn Head Lubricant.

SAE multipurpose lubricant with extreme pressure (EP) performance and meeting NLGI consistency number 0.

John Deere Cotton Picker Spindle Lubricant.

SAE multipurpose lubricant meeting NLGI consistency number 00 and specially compounded to prevent oil separation.

NX,N01,1020,M -19-10FEB87

LUBRICANT STORAGE

Your equipment can operate at top efficiency only if clean lubricants are used.

Use clean containers to handle all lubricants.

Whenever possible, store lubricants and containers in an area protected from dust, moisture, and other contamination. Store containers on their side to avoid water and dirt accumulation.

DX,LUBST -19-01FEB94

LUBRICATION

Check the following lubrication points before the first run-in of the cotton picker units or engine. Lubricate as necessary.

| Component | Service | Measurement | Material |
|-------------------------------------|----------------------|---|---|
| Engine crankcase | Check oil level | To "Full" mark | John Deere TORQ-GARD SUPREME or equivalent, SAE 10W-30 oil |
| Hydraulic reservoir | Check oil level | Halfway on sight glass | John Deere HY-GARD transmission and hydraulic oil or equivalent |
| Transmission and bevel gear housing | Check oil level | To level of fill plug | SAE 85W-140 gear lubricant, API Service GL-5 or MIL-L2105B |
| Hydrostatic drive reservoir | Check oil level | Halfway on sight glass | John Deere HY-GARD transmission and hydraulic oil or equivalent |
| Final Drive housing | Check oil level | To level of fill plug | SAE 85W-140 gear lubricant, API Service GL-5 or MIL-L2105B |
| Unit drive gear cases | Check grease level | Covers lower bevel gear | John Deere Corn Head grease or equivalent |
| Picking unit rock-shaft bearings | Lubricate 3 fittings | Several shots of grease with a hand gun | John Deere or equivalent molybdenum disulfide (EP) lubricant |
| Picking unit universal joints | Lubricant 6 fittings | Two shots of grease with a hand gun | John Deere or equivalent molybdenum disulfide (EP) lubricant |
| Brake pedals and rear countershaft | Lubricate 3 fittings | Several shots of grease with a hand gun | John Deere or equivalent molybdenum disulfide (EP) lubricant |

Fuels and Lubricants/Lubrication

10
15
12

| Component | Service | Measurement | Material |
|---|--|--|--|
| Fan bearings | Lubricate 2 fittings | One shot of grease with a hand gun | John Deere or equivalent molybdenum disulfide (EP) lubricant |
| Unit drive counter-shafts and slip clutches | Lubricate 6 fittings | Two shots of grease with a hand gun | John Deere or equivalent molybdenum disulfide (EP) lubricant |
| Picker bar cams and cam rollers (9920 Only) | Lubricate 4 fittings | 89 mL (3 fl oz) of grease | John Deere Corn Head lubricant or equivalent |
| Sun gears, idler gears, and spindle drive gears (9920 Only) | Lubricate 10 fittings | 21 mL (0.7 fl oz) of grease | John Deere Corn Head lubricant or equivalent |
| Sun gear needle bearings (9920 Only) | Lubricate 4 fittings | 104 mL (3-1/2 fl oz) | John Deere or equivalent molybdenum disulfide (EP) lubricant |
| Picker bars (9920 Only) | Lubricate 4 fittings | Until grease appears at bearing caps | John Deere or equivalent molybdenum disulfide (EP) lubricant |
| Drum slip clutches | Lubricate 2 fittings | Four shots of grease with a hand gun | John Deere or equivalent molybdenum disulfide (EP) lubricant |
| Lower doffer bearings (9920 Only) | Lubricate 4 fittings | Several shots of grease with a hand gun | John Deere or equivalent molybdenum disulfide (EP) lubricant |
| Picker bars, cams, cam rollers, sun gears, idler and spindle drive gears, and needle bearings (9930 Only) | Lube using on-board lubrication system | Check to make sure everything is getting properly lubricated | John Deere Cotton Spindle Lubricant or equivalent |
| Ground drive shaft couplings | Lubricate 4 fittings | Two shots of grease with a hand gun | John Deere or equivalent molybdenum disulfide (EP) lubricant |

NX,N01,1020,O -19-10FEB87

Fuels and Lubricants/Lubrication

| Component | Service | Measurement | Material |
|--|----------------------|---|--|
| Hydrostatic pump drive drive universal joint | Lubricate fitting | Two shots of grease with a hand gun | John Deere or equivalent molybdenum disulfide (EP) lubricant |
| Hydrostatic motor coupling (9920 Only) | Lubricate fitting | Two shots of grease with a hand gun | John Deere or equivalent molybdenum disulfide (EP) lubricant |
| Single guide wheel bearings | Lubricate fitting | Lubricate only as necessary | John Deere or equivalent molybdenum disulfide (EP) lubricant |
| Dual adjustable guide wheels, frame and tie rods | Lubricate 8 fittings | Several shots of grease with a hand gun | John Deere or equivalent molybdenum disulfide (EP) lubricant |
| Basket lift cylinder and rockshaft | Lubricate 4 fittings | Several shots of grease with a hand gun | John Deere or equivalent molybdenum disulfide (EP) lubricant |
| Stabilizer shaft center bearing | Lubricate fitting | Several shots of grease with a hand gun | John Deere or equivalent molybdenum disulfide (EP) lubricant |

NX,N01,1020,I -19-10FEB87

10
15
13

6359 JOHN DEERE ENGINE - USE CTM4

For complete repair information on the 6359 John Deere engine, Component Technical Manual CTM4 is also required.

Use this machine manual for acquiring access to, removal, and installation instructions; and component technical manual for repair and operation and test information.



NX1283,2005,A -19-09JUN93

TS225 -JUN-17 JAN89

20-05-1

6059 JOHN DEERE ENGINE - USE CTM8

For complete repair information on 6059 John Deere engine Component Technical Manual CTM8 is required.

Use this machine manual for acquiring access to, removal, and installation instructions; and component technical manual for repair and operation and test information.



NX1283,2005,B -19-09JUN93

TS225 -JUN-17 JAN89

SERVICE EQUIPMENT AND TOOLS

NOTE: Order tools from the U.S. SERVICEGARD™ Catalog or from the European Microfiche Tool Catalog (MTC). Some tools may be available from a local supplier.

| Name | Use |
|---------------------|-----------------------------------|
| Engine Repair Stand | Hold engine during engine repair. |
| Lifting Sling | To remove and install engine. |

N01,2005,AK -19-12MAR90

SPECIFICATIONS

| Item | Measurement | Specification |
|--|--|---------------------|
| Engine | Cushion Bolts Torque | 81 N·m (60 lb-ft) |
| | R.H. front support bolt torque | 176 N·m (130 lb-ft) |
| | Rear support bolt torque | 230 N·m (170 lb-ft) |
| | Oil fill (9920) | 11.4 L (12 qt) |
| | Oil fill (9930) | 18.9 L (20 qt) |
| Cotton Fan Drive Sheave Bolts | Torque | 115 N·m (85 lb-ft) |
| Engine Position | Fan manifold-to-engine flywheel (9920) | 79 mm (3.10 in.) |
| | Fan manifold-to-engine flywheel (9930) | 155 mm (6.10 in.) |
| Hydraulic Pump Drive Belt | Static tension | 845 N (190 lb) |
| Air Conditioning Compressor Drive Belt | Tension (new) | 600 N (135 lb). |
| | Tension after run-in | 401 N (90 lb) |
| Exhaust Clamp (9930) | Torque | 27 N·m (20 lb-ft) |
| Radiator | Fill (9920) | 30.3 L (32 qt) |
| | Fill (9930) | 32.2 L (34 qt) |

NX1283,2005,C -19-09JUN93

REMOVE ENGINE

NOTE: Use the following procedure to remove either the 6359 or 6059 engine. Alternate procedures are shown where applicable.

CAUTION: Allow adequate overhead clearance before raising basket.

On 9920 Pickers, block basket at each lift cylinder to prevent it from falling in event of hydraulic pressure loss. Use an adequate length of angle iron, clamped securely to cylinder rods to prevent basket from coming down causing personal injury if hydraulic line becomes ruptured.

On 9930 Pickers, after basket has been raised, engage cylinder lock valve lever to "LOCK" position before working under basket. Failure to lock cylinders could allow basket to drop if a hydraulic line is ruptured. This could cause personal injury.

1. Raise basket and block it up or turn basket cylinder lock valve to "LOCK".

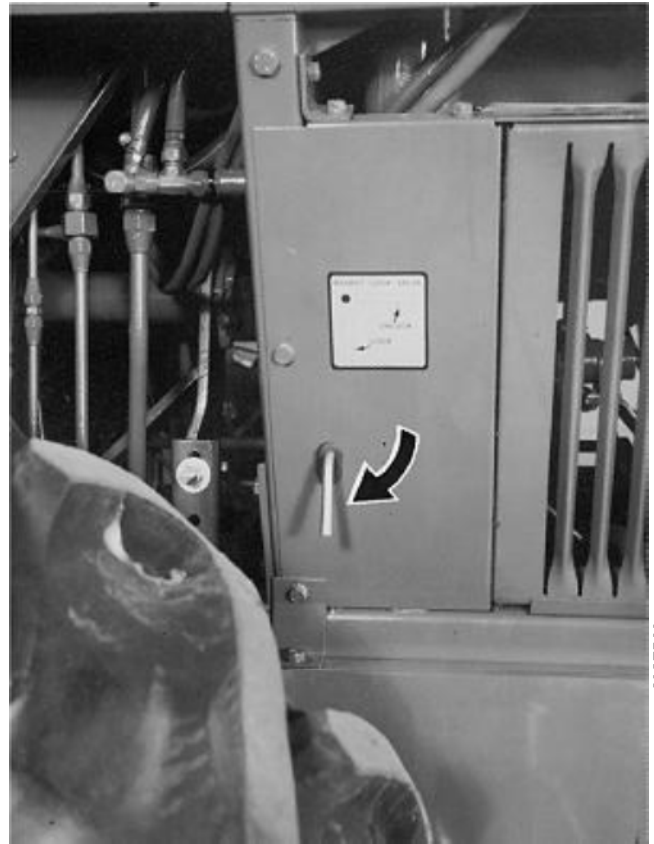

9930 Picker Shown

NX1283,2005,D -19-30MAR94

2. Remove louvered side shields from each side of machine.

3. On 9920 Pickers only, remove clamps (A) securing hoses to hood center support.



NX1283,2005,E -19-09JUN93

Remove and Install/Engine

4. Remove radiator cover (A) and engine hood (B).

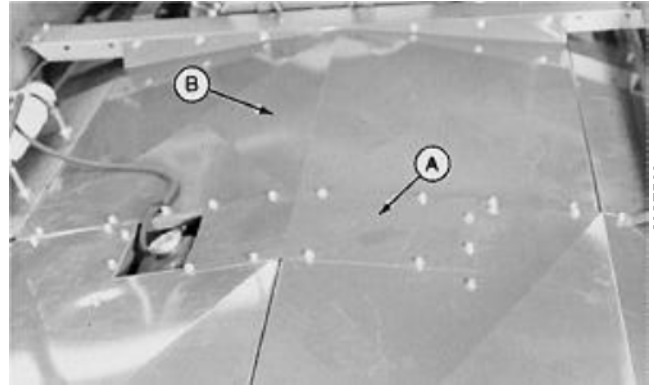

NX,N01,2005,CL -19-11FEB87

NB6234F1 -JUN-28SEP88

5. On 9920 Pickers, to remove the battery:

- Disconnect battery cables (A).
- Remove hold down clamp.
- Remove battery (B).

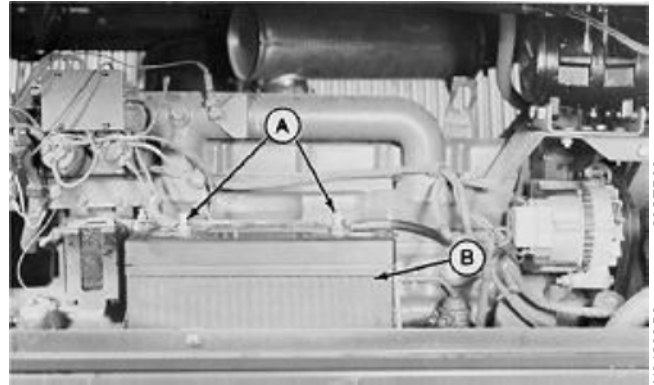

NX1283,2005,F -19-20SEP93

NB4289G3 -JUN-28SEP88

6. On 9930 Pickers, to remove the battery:

- Remove left-hand rear screen.
- Remove flange screws (A) from each side of battery box.

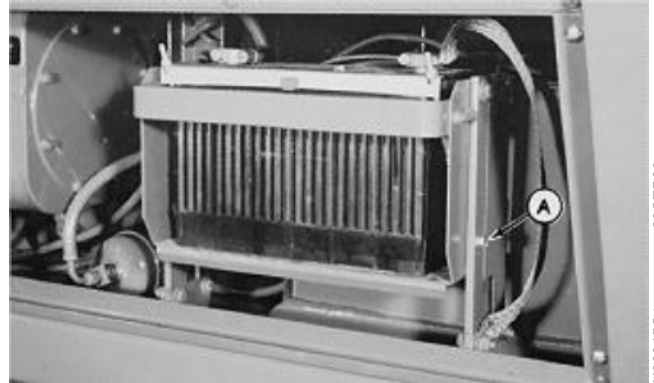

NX1283,2005,G -19-20SEP93

NB6345C1 -JUN-28SEP88

- With both hands on handle (A), slowly lower battery box.
- Disconnect ground cable (B).

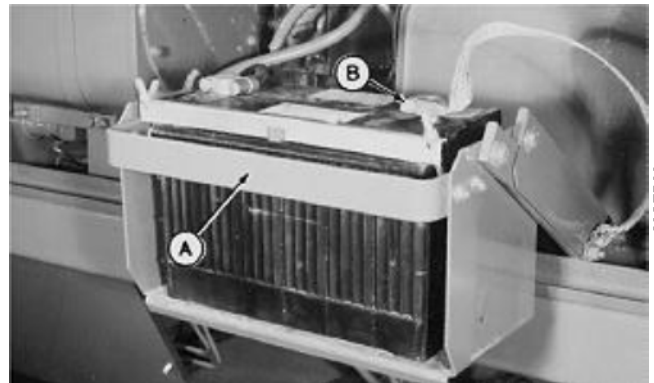

NX1283,2005,H -19-09JUN93

NB6345D1 -JUN-28SEP88

IMPORTANT: Plug fuel supply hose to prevent fuel loss. Leaving hose unplugged may drain fuel tank.

7. Disconnect fuel supply hose (A) from fuel pump (B).
8. Disconnect return hose (C).

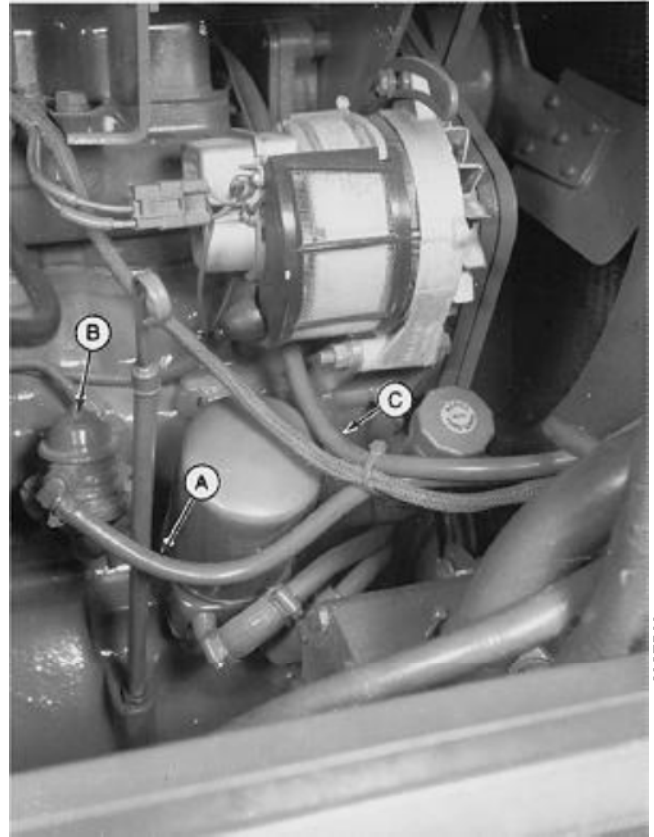

NX1283,2005,I -19-09JUN93

51920
-JUN+28SEP88
NB2243B8

CAUTION: Explosive release of fluids from pressurized cooling system can cause serious burns.

Shut off engine. Only remove filler cap when cool enough to touch with bare hands. Slowly loosen cap to first stop to relieve pressure before removing completely.

9. Drain and discard engine coolant, at radiator (A), oil cooler (B) and at left-hand side of engine block.

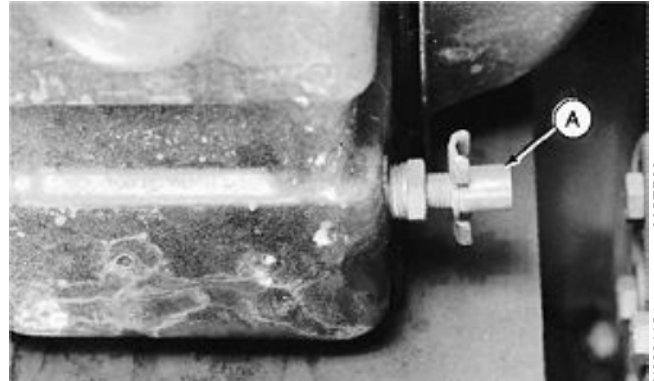

NX1283,2005,J -19-09JUN93

10. Remove upper (A) and lower radiator hoses.

11. Remove upper heater hose (B).

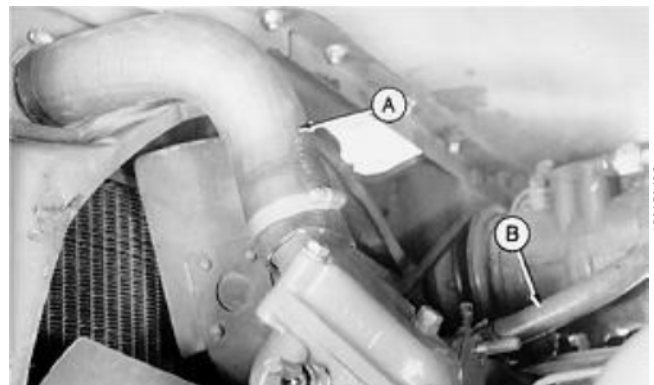

9930 (P.I.N. 2481-) Shown

NX1283,2005,K -19-09JUN93

Remove and Install/Engine

12. Loosen eight radiator mounting bolts (A) and tilt radiator back.

13. Remove four engine fan screws. Remove fan.

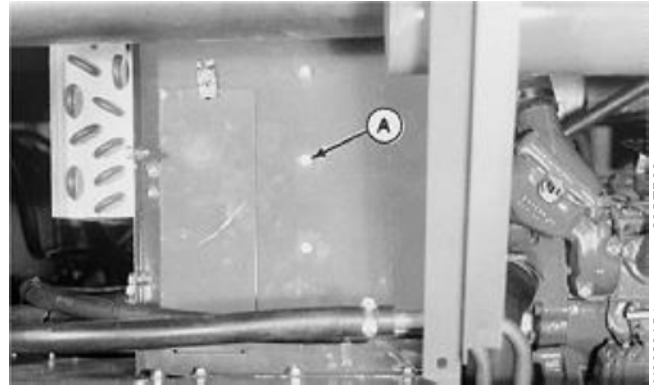

NX1283,2005,L -19-09JUN93

N86234C1 -JUN-28SEP88

7510

13. On 9920 Pickers, S.N. -380, remove pre-cleaner hose from muffler (if equipped).

14. On 9920 Pickers only, loosen clamps (A) and remove muffler.

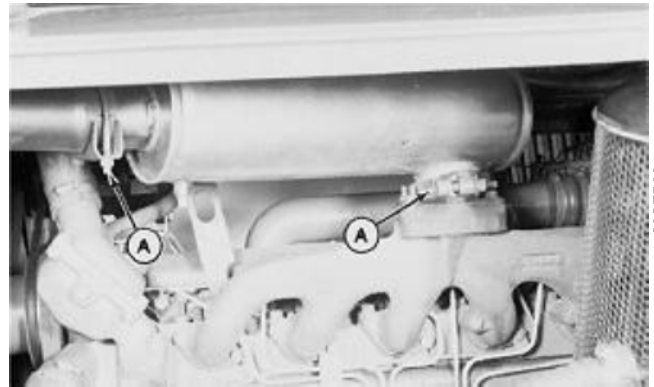

NX1283,2005,M -19-20SEP93

N84025L2 -JUN-28SEP88

15. On 9930 Pickers only, remove elbow (A) between turbocharger exhaust port and tail pipe.

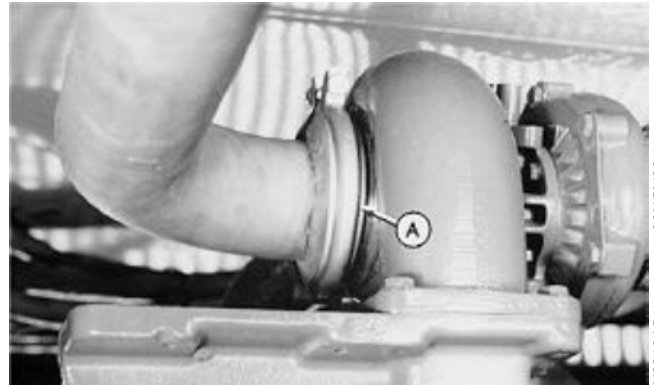

NX1283,2005,N -19-20SEP93

N88194C1 -JUN-30NOV88

9930 (P.I.N. 2481-) Shown

16. Disconnect throttle cable (A) from injection pump.

17. Remove clamp (B) and wire throttle cable to main frame.

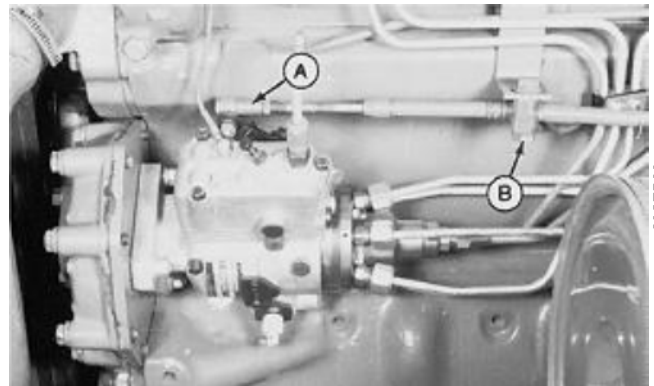

NX1283,2005,O -19-20SEP93

N84025M4 -JUN-28SEP88

18. On 9920 Pickers only, loosen clamps (A).
19. Remove air intake tube (B).

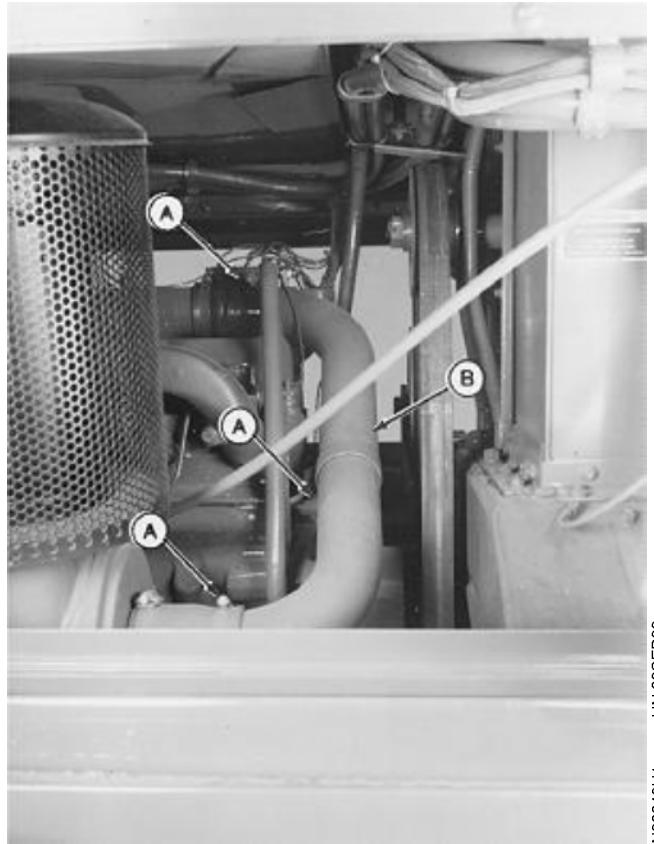

NB2243H1 -JUN-28SEP88

NX1283,2005,P -19-09JUN93

20. On 9930 Pickers only, disconnect air sender wire (A).
21. Remove air sender (B) and ground wire.
22. Loosen clamp (C) and air tube out of rubber elbow.
23. Cap both air tube openings and plug sender opening.

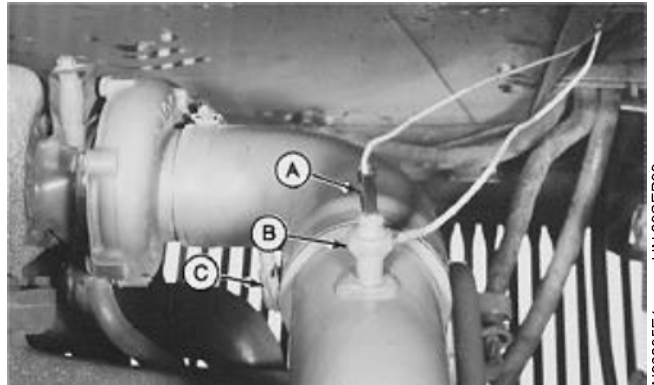

N86295E1 -JUN-28SEP88

NX1283,2005,Q -19-20SEP93

24. Loosen clamp (A) and rotate elbow out-of-the-way.

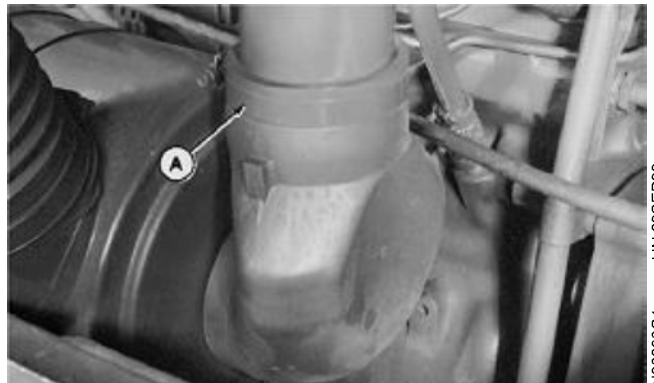

N86296G1 -JUN-28SEP88

NX1283,2005,R -19-09JUN93

Remove and Install/Engine

25. Close heater valve.

26. Disconnect rear heater hose (A).



N86261Y1 -JUN-28SEP88

9920

NX1283,2005,S -19-09JUN93

27. Disconnect the wiring harness from following engine components:

- | | |
|----------------------------|-------------------------|
| Air Restriction Indicator | Oil Pressure Sender |
| Coolant Temperature Sender | Starter Motor (5 wires) |
| Alternator | Ether Start Solenoid |
| Air Conditioner Compressor | Engine Ground Wire |
| | Safety Start Switch |

28. Unclamp harness (A) from along engine.

29. Remove two electrical load center screws (B).

30. Move load center to side of frame. DO NOT disconnect wires from panel.

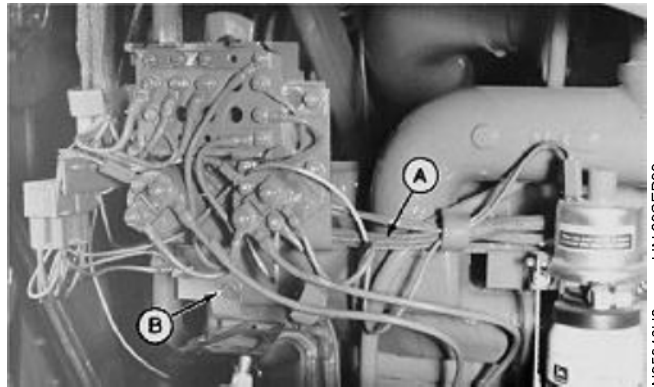

N85346U2 -JUN-28SEP88

NX1283,2005,T -19-20SEP93

31. On 9920 Pickers only, disconnect tachometer cable (A). Save the gasket which may come off with cable. Plug cable opening in back of engine block.

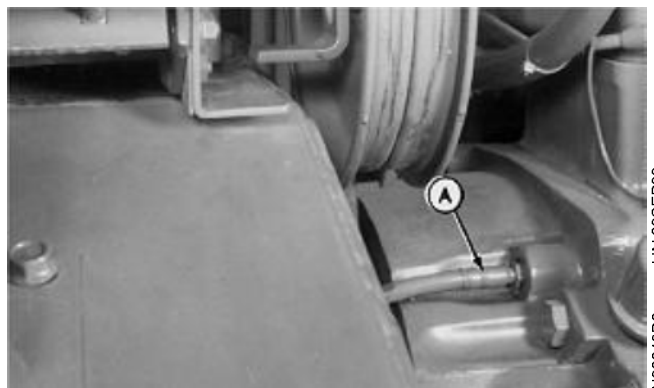

N82243D2 -JUN-28SEP88

NX1283,2005,U -19-09JUN93

Remove and Install/Engine

32. On 9930 Pickers only, at connector (A), disconnect electronic tachometer harness.

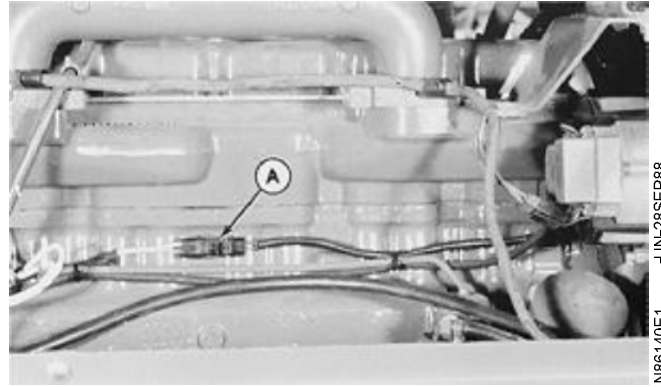

NB6140E1
-JUN-28SEP88

NX1283,2005,V -19-09JUN93

33. On 9930 Pickers, disconnect engine ground strap (A) from frame.



N93278P1
-JUN-16MAR94

9930 Picker (P.I.N. 8001-12065)

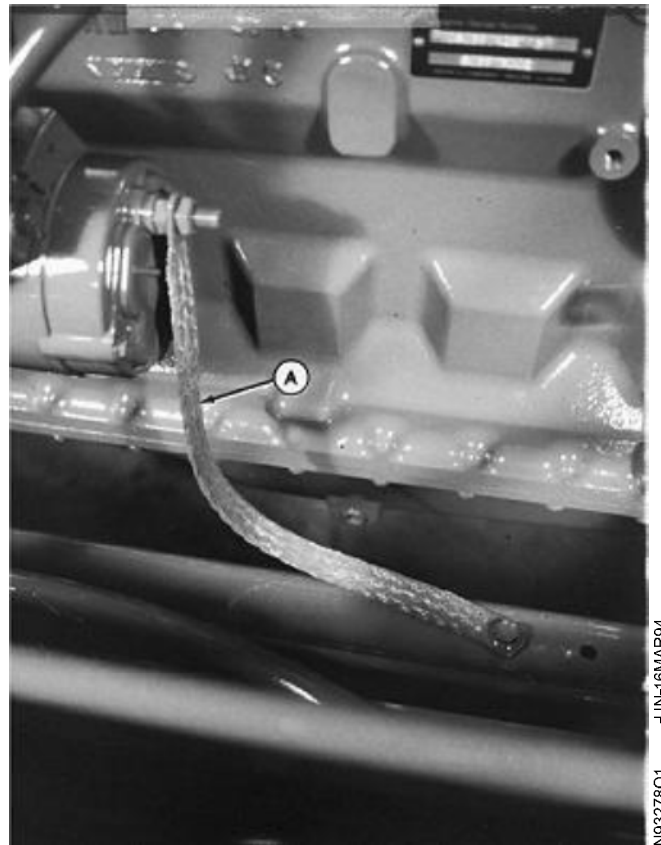

N93278O1
-JUN-16MAR94

9930 Picker (P.I.N. 12066-)

NX1283,2005,AC -19-15OCT93

20
05
10

Remove and Install/Engine

34. On 9920 Pickers only, move lift strap from lower left-hand side of engine to top of engine.

35. Loosen bolt (A) to loosen air conditioner compressor drive belt. Remove belt.

36. Remove compressor mounting bracket (B) from support (C). Wire compressor to main frame.

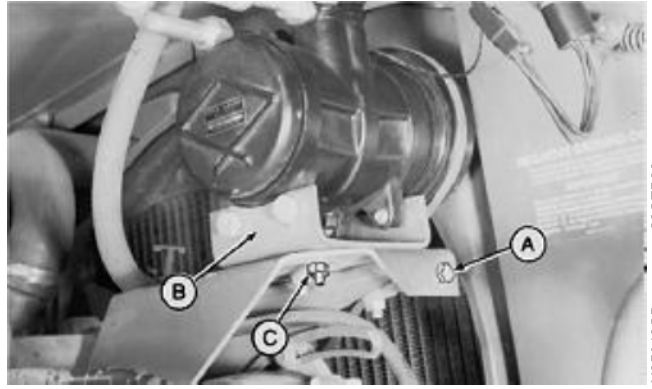

NX1283,2005,W -19-20SEP93

N85046C5 -UN-28SEP88

200511

37. Loosen nut (A) to loosen hydraulic pump belt.

38. Remove belt.

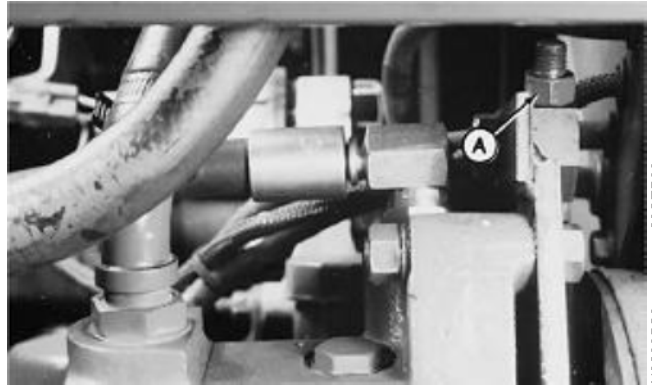

NX1283,2005,X -19-09JUN93

N82335C3 -UN-28SEP88

39. Remove pump bracket pivot bolts (A).

40. Remove pump mounting bracket. DO NOT DISCONNECT HOSES. Wire pump to engine support frame.

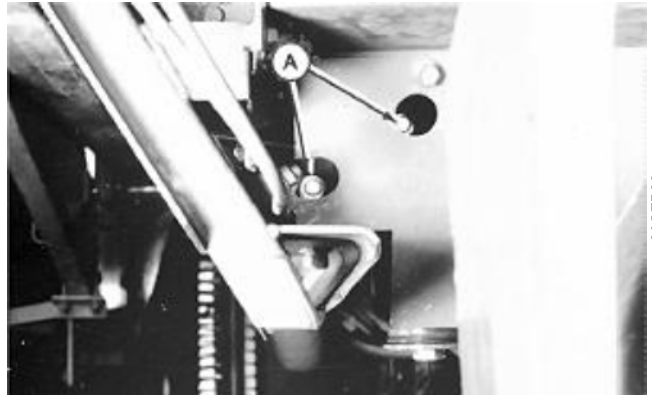

NX1283,2005,Y -19-09JUN93

N82335D1 -UN-30SEP88

9920 Picker Shown

41. Remove belt guide (A).

42. Slip fan drive belt (B) off drive sheave.

43. Remove hydrostatic drive driveline (C).

44. Remove fan drive sheave from flywheel.

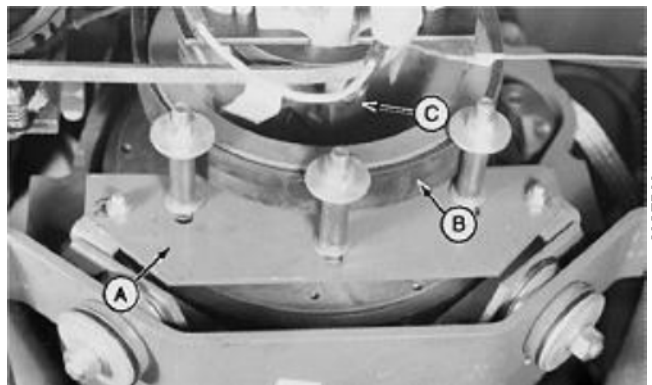

NX1283,2005,Z -19-09JUN93

N8623411 -UN-28SEP88

9930 Picker Shown

CAUTION: Use extreme caution when lifting engine. NEVER permit any part of your body to be positioned under an engine being lifted or suspended.

Engine weighs approximately 464 kg (1023 lb). Use proper capacity lifting device to remove engine.

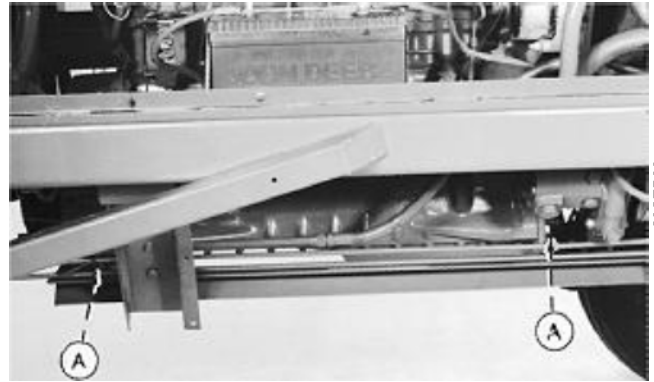

NB2245A2 -UN-28SEP88

20
05
12

45. Connect JDG-23A Lift Bar and Chains to lift straps. Take up slack in chains.

46. Remove engine mounting bolts (A).

47. Slowly lift engine up and out of frame. On 9330 Pickers, avoid striking lubrication system pump.

NX1283,2005,AA -19-09JUN93

INSTALL ENGINE

1. Before installing engine, check condition of rubber cushions and replace as necessary. Tighten to specified torque.
2. Apply T43513 Thread Lock and Sealer (High Strength) to fan drive sheave bolts. Tighten to specified torque.
3. Locate engine so spacing between rear of fan manifold and face of engine flywheel is 79 mm (3.10 in.) for 9920 Pickers and 115 mm (6.10 in.) for 9930 Pickers.
4. Adjust radiator to allow the engine fan to extend outside shroud by 1/3 to 1/2 of fan's width.
5. Fill engine crankcase with John Deere TORQ-GARD SUPREME® engine oil. (See Engine Oils in Section 10.)
6. Fill radiator with a 50/50 mixture of ethylene glycol and water.
7. Bleed fuel system prior to start-up. (See Bleed Fuel System in Section 30.)
8. Check and adjust engine slow and fast idle. (See Check Engine Speed [No Load] in Section 30.)
9. After major engine repairs or installation of a short block, run-in engine. (See Engine Break-in Instructions in CTM4 and CTM8.)

Torque Specifications

| | |
|---|------------------------|
| 5/8 x 3-1/2 in. cushion bolts | 81 N·m (60 lb-ft) max. |
| Fan drive sheave bolts | 115 N·m (85 lb-ft) |
| R.H. front engine support screws | 176 N·m (130 lb-ft) |
| Engine rear support screws | 230 N·m (170 lb-ft) |
| Exhaust elbow clamp screws (9930) | 27 N·m (20 lb-ft) |

Belt Tension

| | |
|--|----------------------------|
| Hydraulic pump drive belt | 845 N (190lb) static |
| Air conditioning compressor belt | 600 N (135 lb) (new) |
| | 401 N (90 lb) after run-in |

Capacity Specifications

| | |
|----------------------------|------------------|
| Crankcase (9920) | 11.4 L (12 qt) |
| Crankcase (9930) | 18.9 L (20.0 qt) |
| Radiator (9920) | 30.3 L (32 qt) |
| Radiator (9930) | 32.2 L (34 qt) |

20
05
14

SERVICE EQUIPMENT AND TOOLS

NOTE: Order tools from the U.S. SERVICEGARD™ Catalog or from the European Microfiche Tool Catalog (MTC). Some tools may be available from a local supplier.

| Name | Use |
|---------------|---------------------------------|
| Pressure Pump | Test radiator and radiator cap. |

NX,N01,2010,DV -19-27MAR92

SPECIFICATIONS

| Item | Measurement | Specification |
|--------------------------------------|---------------|------------------------|
| Radiator Cap | Test Pressure | 41—55 kPa (6—8 psi) |
| Radiator | Test Pressure | 55 kPa (8 psi) |
| Engine Fan Extends Outside of Shroud | Distance | 1/3 to 1/2 fan's width |
| Fan-to-Fan Pulley Cap Screws | Torque | 47 N·m (35 lb-ft) |

NX,CST2010,B -19-27MAR92

20
10
1



Suggest:

If the above button click is invalid.

Please download this document

first, and then click the above link

to download the complete manual.

Thank you so much for reading

ACQUIRE ACCESS TO WATER PUMP

1. Disconnect chassis wiring harness (A) from alternator (B) or alternator harness.
2. Remove alternator, belt, and mounting bracket (C).
3. Loosen air conditioner compressor (D) belt and remove.

A—Wiring Harness
B—Alternator
C—Alternator Bracket
D—A.C. Compressor
E—Heater Hose

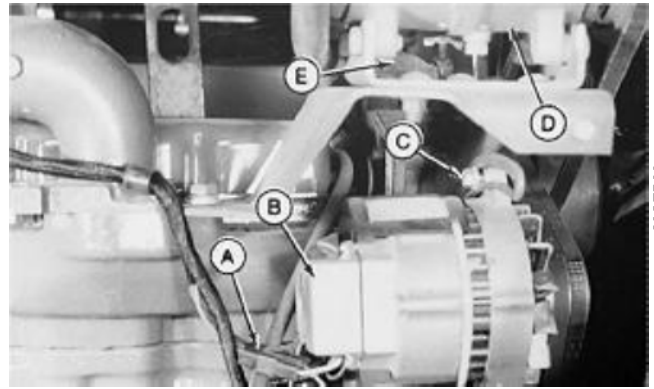

9920, 9930 (P.I.N. -2000)

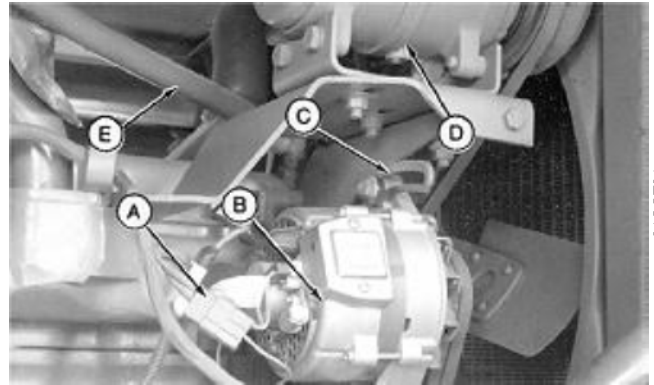

9930 (P.I.N. 2001-12000)

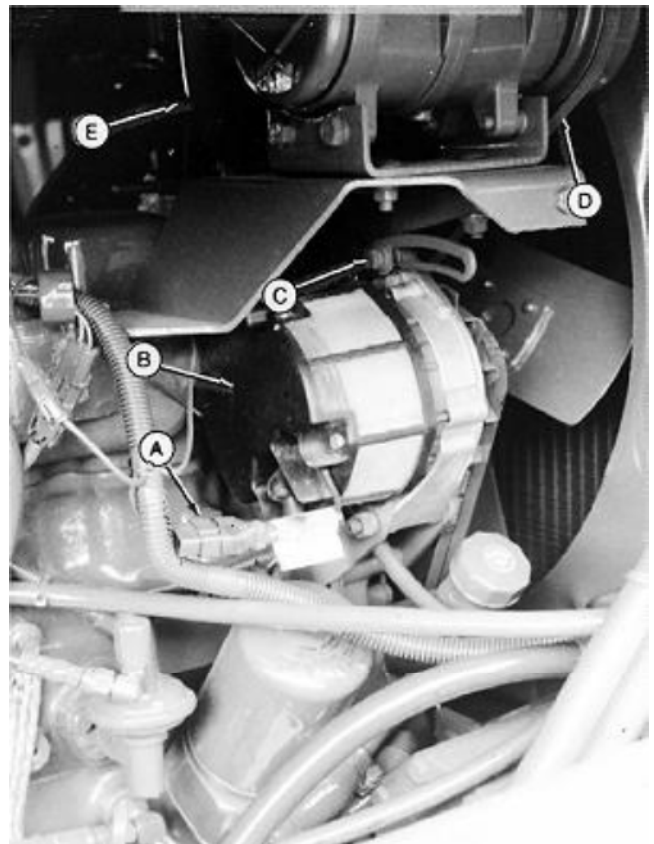

9930 (P.I.N. 12001-)

NX1283,2010,A -19-15OCT93

<https://www.ebooklibonline.com>

Hello dear friend!

Thank you very much for reading.

Enter the link into your browser.

The full manual is available for immediate download.

<https://www.ebooklibonline.com>