

# John Deere 7630 Knuckleboom Loader



JOHN DEERE

## TECHNICAL MANUAL John Deere 7630 Knuckleboom Loader

TM1147 (01OCT75) English

**TM1147 (01OCT75)**

LITHO IN U.S.A. (G) NEW  
ENGLISH



## 7630 KNUCKLEBOOM LOADER

Technical Manual  
TM-1147 (Oct-75)

### CONTENTS

- Section 10 - GENERAL
  - Group 5 Specifications
  - Group 10 Lubricants
  - Group 15 Separation
- Section 20 - ENGINE
  - Group 5 Diagnosing Malfunctions
  - Group 10 Separation and Installation
  - Group 15 Basic Engine
  - Group 20 Engine Lubrication
  - Group 25 Speed Control Linkage
  - Group 30 Engine Cooling System
  - Group 35 Specifications and Special Tools
- Section 30 - FUEL SYSTEM
  - Group 5 Diagnosing Malfunctions
  - Group 10 Fuel Tank, Fuel Filter, Fuel Transfer Pump
  - Group 15 Fuel Injection Pump
  - Group 20 Specifications
- Section 40 - ELECTRICAL SYSTEM
  - Group 5 Wiring Diagrams
  - Group 10 Charging System
  - Group 15 Starting Motor
  - Group 20 Electrical Swivel
  - Group 25 Specifications
- Section 50 - HYDRAULIC SYSTEM
  - Group 5 General Information and Malfunction Diagnosis
  - Group 10 Hydraulic Pump
  - Group 15 Reservoir, Filters, and Oil Cooler
  - Group 20 Main Valve
  - Group 25 Stabilizer Valve (Cab Mount)
  - Group 30 Stabilizer Valve (Rear Mount)
  - Group 35 Swing Motor
  - Group 40 Motion Control Valve
  - Group 45 Hydraulic Swivels
  - Group 50 Selector Valve
  - Group 55 Grapple Inline Crossover Relief Valve
  - Group 60 Hydraulic Cylinders
  - Group 65 Control Lever Linkage
  - Group 70 Grapple Standard Orbit Motor
  - Group 75 Grapple High Torque Orbit Motor
  - Group 80 Specifications
- Section 60 - MISCELLANEOUS
  - Group 5 Grapples
  - Group 10 Stabilizer
  - Group 15 Cab (Rear Mount)

### SI (International System) UNITS OF MEASURE

Metric equivalents have been included, where applicable, throughout this technical manual.

*All information, illustrations and specifications contained in this technical manual are based on the latest information available at the time of publication. The right is reserved to make changes at any time without notice.*

Copyright 1976  
DEERE & COMPANY  
Moline, Illinois  
All rights reserved

## INTRODUCTION

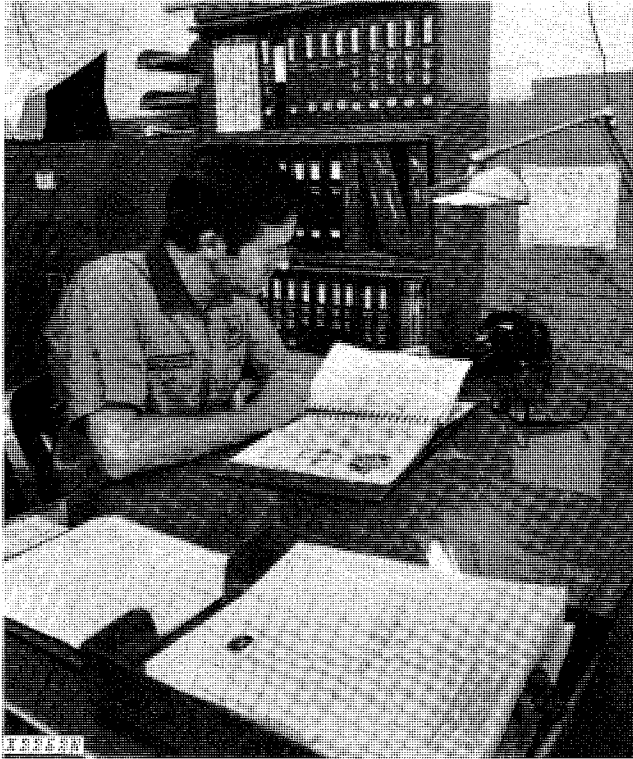

*Use FOS Manuals for Reference*

This technical manual is part of a twin concept of service:

### **FOS Manuals - for reference**

### **Technical Manuals - for actual service**

The two kinds of manuals work as a team to give you both the general background and technical details of shop service.

Fundamentals of Service (FOS) Manuals cover basic theory of operation, fundamentals of trouble shooting, general maintenance, and basic types of failures and their causes. FOS Manuals are for training new personnel and for reference by experienced service technicians.

Technical Manuals are concise service guides for a specific machine. Technical Manuals are on-the-job guides containing only the vital information needed by an experienced service technician.



*Use Technical Manuals for Actual Service*

Some features of this technical manual:

- Table of contents at front of manual
- Exploded views showing parts relationship
- Photos showing service techniques
- Specifications grouped for easy reference

This technical manual was planned and written for you - an experienced service technician. Keep it in a permanent binder in the shop where it is handy. Refer to it whenever in doubt about correct service procedures or specifications.

Using the technical manual as a guide will reduce error and costly delay. It will also assure you the best in finished service work.

**<https://www.ebooklibonline.com>**

Hello dear friend!

Thank you very much for reading.

Enter the link into your browser.

The full manual is available for immediate download.

**<https://www.ebooklibonline.com>**

## MAINTENANCE WITHOUT ACCIDENT WORK SAFELY



T27999N

 This safety alert symbol identifies important safety messages in this manual and on the loader. When you see this symbol, be alert to the possibility of personal injury and carefully read the message that follows.

**EVERY EMPLOYER HAS A  
SAFETY PROGRAM. KNOW  
WHAT IT IS!**

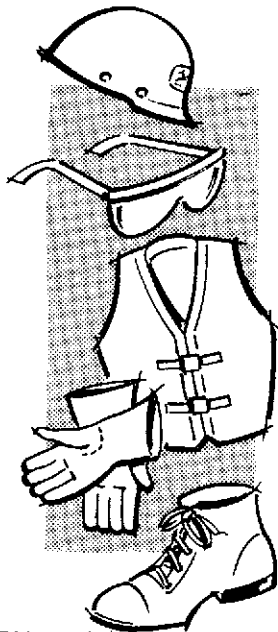

T27501N

Consult your shop supervisor for specific instructions on a job, and the safety equipment required.

For instance, you may need: Hard hat, safety shoes, safety goggles, heavy gloves, reflector vests, ear protectors, respirators.

Litho in U.S.A.



T27502N

ALWAYS AVOID loose clothing or any accessory - flopping cuffs, dangling neckties and scarves, or rings and wrist watches - that can catch in moving parts and put you out of work.

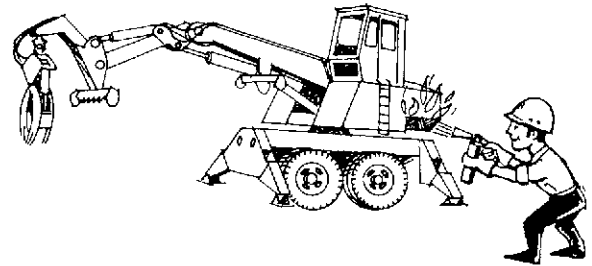

G8396N

### BE ALERT!

Plan ahead—work safely—avoid accidental damage and injury. If a careless moment does cause an accident or fire, react quickly with the tools and skills at hand—know how to use a first aid kit and a fire extinguisher—and where to get aid and assistance. In an emergency split-second action is the key to safety.

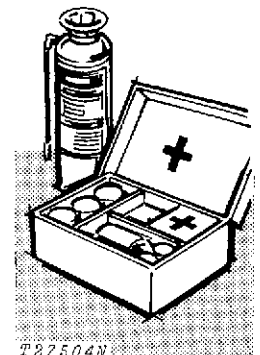

T27504N

## MAINTENANCE WITHOUT ACCIDENT—Continued

Specific safety procedures should always be observed, whether servicing the equipment or making the repairs. Remembering these—in time!—can prevent an injury ... or save your life ...

### AVOID FIRE HAZARDS

#### Fuel is Dangerous!

Don't smoke while refueling.

Don't smoke while handling highly flammable material.

Engine should be shut off when refueling.

Use care in refueling if the engine is hot.

Don't use open pans of gasoline or diesel fuel for cleaning parts. Good commercial, nonflammable solvents are preferred.

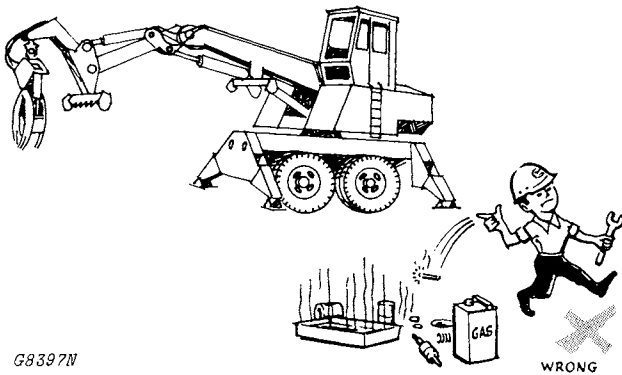

#### Battery Gas Is Highly Flammable!

Provide adequate ventilation when charging batteries.

Don't check battery charge by placing metal objects across the posts.

Don't allow sparks or open flame near batteries.

Don't smoke near battery.

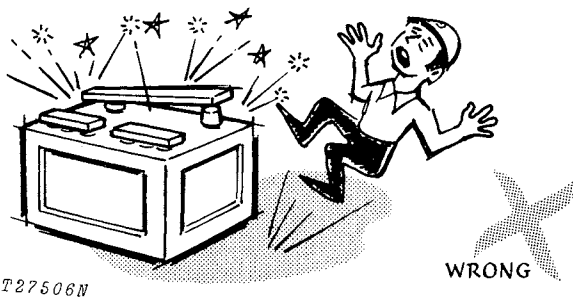

#### Flame Is Not A Flashlight!

Never check fuel, battery electrolyte or coolant levels with an open flame.

Never use an open flame to look for leaks anywhere on the equipment.

Never use an open flame as a light anywhere on or around the equipment.

KNOW WHERE FIRE EXTINGUISHERS ARE KEPT!

### UNDER ALL MAINTENANCE CONDITION -

Do not perform any work on the equipment unless authorized to do so. Then be sure you know what you're doing. Follow recommended procedures.

Never service the equipment while it is being operated.

Avoid working on equipment with the engine running. If it is necessary to make checks with the engine running, ALWAYS USE TWO SERVICE TECHNICIANS—one, the operator, at the controls, the other checking in view of the operator. Also, put the transmission in neutral, set the brake, and apply any safety locks provided. KEEP HANDS AWAY FROM MOVING PARTS.

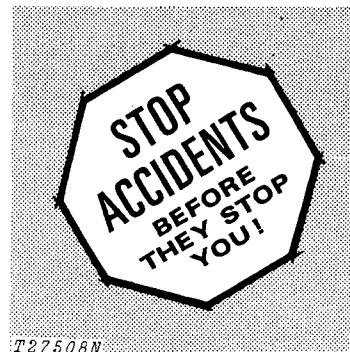

## MAINTENANCE WITHOUT ACCIDENT

Before servicing, adjusting, or repairing - LOWER attachments to the ground - or, if necessary to raise them for access to certain parts, **SECURELY SUPPORT** by external means. **DO NOT** rely on controls to support or position attachments for maintenance.

Never allow **ANYONE** to walk under equipment that is raised and not properly blocked.

Avoid working directly under raised and blocked equipment unless absolutely necessary.

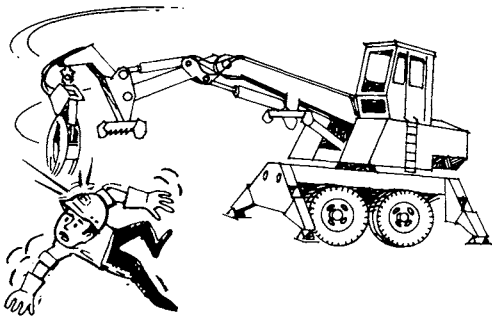

G8398N

If the machine is on an incline, block it securely.

Use hoisting equipment for lifting heavy parts. **TAKE CARE! WATCH OUT FOR OTHER PEOPLE IN THE VICINITY.**

Use extreme caution in removing radiator caps, drain plugs, grease fittings, or hydraulic pressure caps.

Wear safety glasses when drilling, grinding, or hammering metal.

Make sure the maintenance area is adequately vented.

Keep maintenance area **CLEAN AND DRY**. Oily and wet floors are slippery; greasy rags are a fire hazard; wet spots are dangerous when working with electrical equipment.

Store starting aids in a cool and well-ventilated place, out of the reach of unauthorized personnel.

### SERVICING PRECAUTIONS

Stop the engine before cleaning or lubricating the equipment.

Lower mounted equipment and tools to the ground carefully.

Engine coolant gets hot! Don't remove the radiator cap until coolant temperature is below the boiling point. Then turn cap slightly to relieve pressure before removing.

Exhaust gases are dangerous! Periodically check exhaust system for excessive leakage.

Don't forget a hydraulic system may be pressurized! To relieve pressure, follow the technical manual.

When checking hydraulic pressure, be sure to use the correct test gauge for the pressure in the particular system.

## MAINTENANCE WITHOUT ACCIDENT—Continued

Keep ALL equipment free of dirt and oil. This attention will minimize fire hazards and facilitate spotting of loose or defective parts.

When preparing engine for storage, remember that inhibitor is volatile and therefore dangerous. Seal and tape openings after adding the inhibitor. Keep container tightly closed when not in use.

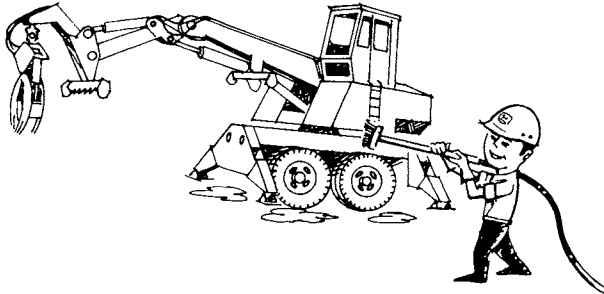

G8398N

Before removing any housing covers, stop engine. Take all objects from your pockets which could fall into the opened housings. Don't let adjusting wrenches fall into opened housing.

### .... for Maintenance Adjustments

Don't attempt to check belt tension while the engine is running.

Don't adjust the fuel system while the machine is in motion.

## PRECAUTIONS DURING REPAIR

Before working on the engine fuel system—close fuel shutoff valve.

Before working on hydraulic system—make sure engine is not running and the system pressure is relieved by working the control levers in all directions with the engine shut off.

Never let your bare hands come in contact with the sharp edges. **WEAR GLOVES.**

Before repairing the electrical system, or performing a major overhaul, make sure the batteries are disconnected.

# Section 10 GENERAL

## CONTENTS OF THIS SECTION

### GROUP 5 - SPECIFICATIONS

7630 (Cab) Loader Design .....	5-3
Serial Number (Cab Mount .....	5-3
7630 (Rear) Loader Design .....	5-4
Serial Number (Rear Mount) .....	5-4
Loader Specifications .....	5-5
Grapples .....	5-6
Boom Lift Capacities (Cab Mount and Rear Mount) .....	5-7
Cab Mount View Side View .....	5-8
Rear Mount Side View .....	5-9
Rear Mount Rear View .....	5-10

### GROUP 10 - LUBRICANTS

Lubricants .....	10-1
Lubrication and Periodic Service .....	10-2
Lubrication and Service Intervals .....	10-2
Periodic Service Chart (Cab Mount) .....	10-3
Cab Mount Lubrication .....	10-4 - 10-6
Periodic Service Chart (Rear Mount) .....	10-7 - 10-8
Rear Mount Lubrication .....	10-9 - 10-12

### GROUP 15 - SEPARATION

General .....	15-1
Separating the 7630 Cab Mount from the Truck .....	15-2
Separating the 7630 Rear Mount from the Truck Frame .....	15-3 - 15-4
Installing Loader Onto Truck .....	15-4

## Group 5 SPECIFICATIONS

### 7630 CAB MOUNT

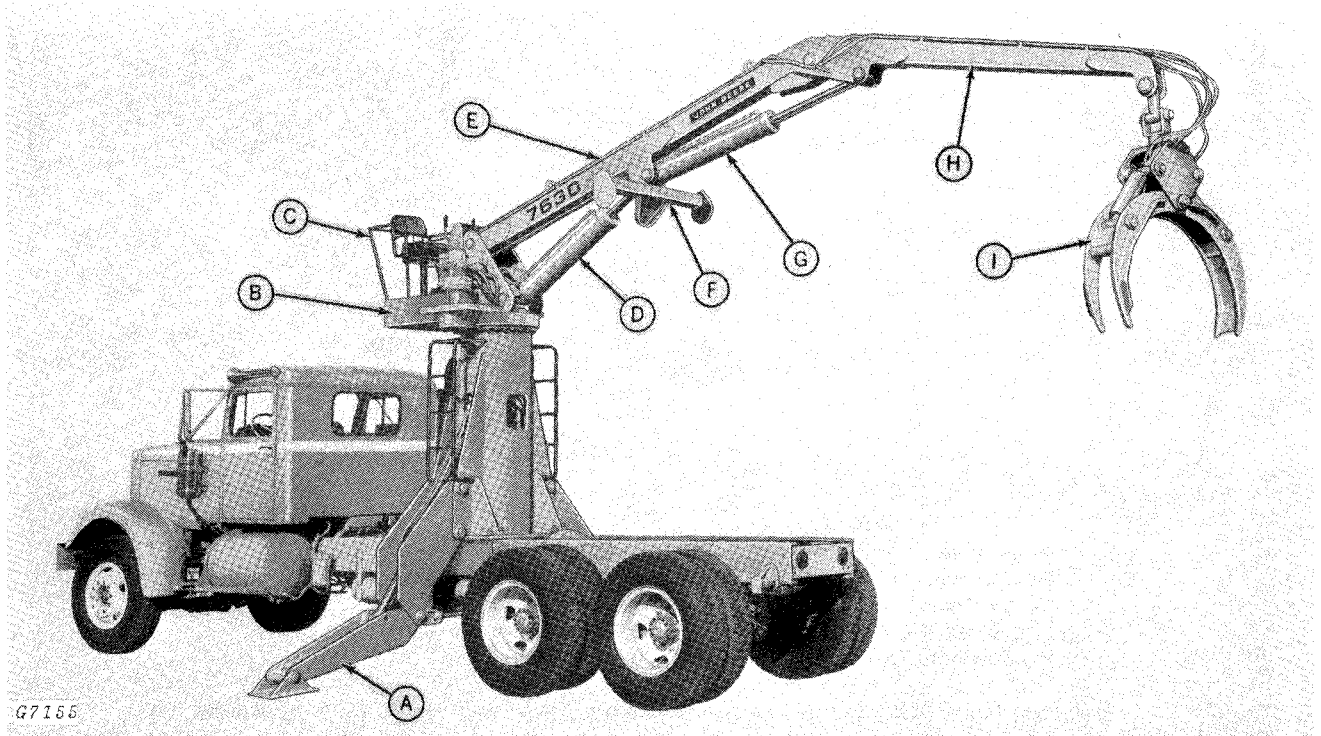

- |                      |                     |
|----------------------|---------------------|
| A—Stabilizer         | F—Heel              |
| B—Operating Platform | G—Jib Boom Cylinder |
| C—Hand Railing       | H—Jib Boom          |
| D—Main Boom Cylinder | I—Grapple           |
| E—Main Boom          |                     |

Fig. 1—John Deere 7630 (Cab Mounted) Knuckleboom Loader with 44-Inch (1.11 m) Grapple

### SERIAL NUMBER

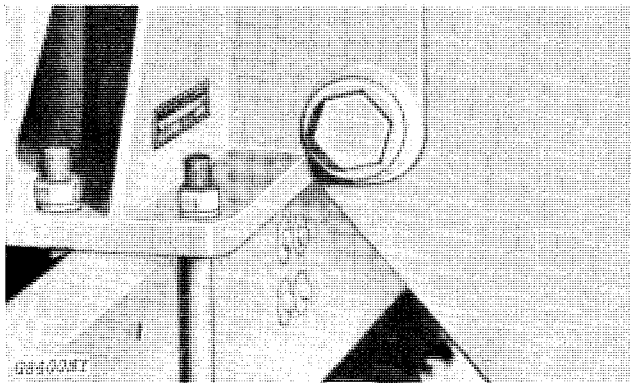
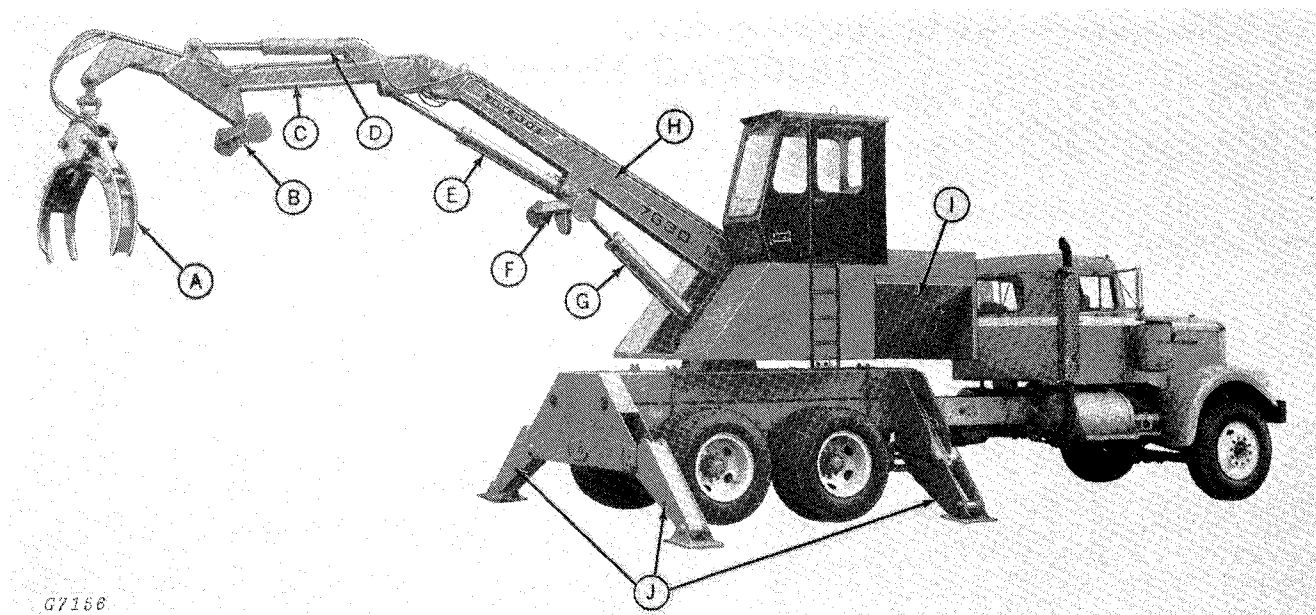

Fig. 2—Cab Mount Serial Number

The loader serial number on the 7630 Cab Mount Knuckleboom Loader is located on the lower front left-hand side of the mounting frame.

## 7630 REAR MOUNT



- A—Grapple
- B—Live Heel
- C—Jib Boom
- D—Live Heel Cylinder
- E—Jib Boom Cylinder
- F—Heel
- G—Main Boom Cylinder
- H—Main Boom
- I—Engine Service Panel
- J—Stabilizers

Fig. 3—John Deere 7630 (Rear Mounted) Knuckleboom Loader with 44-Inch (1.11 m) Grapple

### SERIAL NUMBER

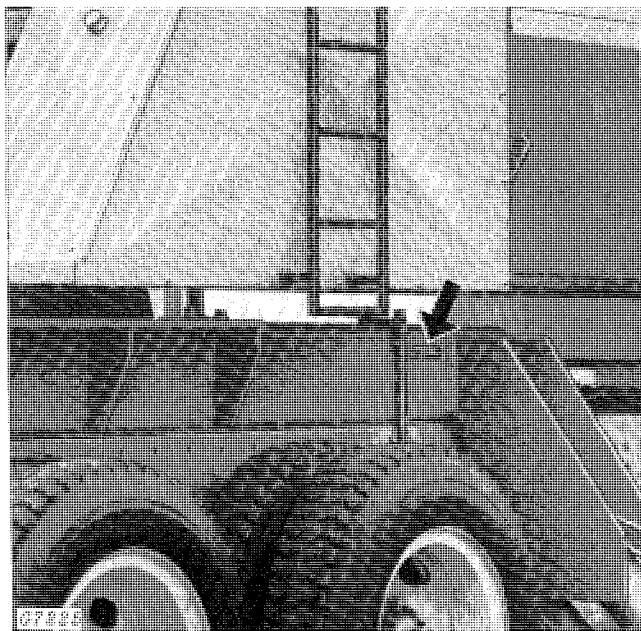

Fig. 4—Rear Mount Serial Number

The loader serial number on the 7630 Rear Mount Knuckleboom Loader is located on the lower rear left-hand side of the mounting frame.

## LOADER SPECIFICATIONS

### Operating Information:

#### Maximum loading reach:

Cab mount .....21 ft. 6 in. (6.55 m)  
Rear mount w/live heel .....23 ft. (7.01 m)  
Swing system ..... Turntable  
Swing arc .....360° continuous  
Swing torque .....20,000 lb-ft (2766 kg-m)  
Swing speed .....6 rpm

#### Stabilizer spread:

Cab mount .....15 ft. 6 in. (4.72 m)  
Rear mount, front .....11 ft. 6 in. (3.51 m)  
Rear mount, rear .....15 ft. 4 in. (4.67 m)  
Stabilizer area, each .....256 sq. in. (1652 cm<sup>2</sup>)

Grapple rotation .....360°  
Grapple swing torque .....175 lb-ft (24.2 kg-m)

#### Grapple opening, maximum:

40 in. (1.02 m) grapple .....40 in. (1.02 m)  
44 in. (1.12 m) grapple .....44 in. (1.12 m)  
1/4 cord (0.9 m<sup>3</sup>) grapple .....50 in. (1.27 m)

#### Transport height:

Cab mount .....13 ft. 2 in. (4.01 m)  
Rear mount .....13 ft. (3.96 m)  
Maximum transport width .....8 ft. (2.44 m)

### Mounting:

Mounting frame integral with main frame. Brackets supplied for universal mounting. Bolts to truck frame.

### Hydraulic Cylinders:

Main .....7x36 in. (178x914 mm), double-acting  
Jib .....6x36 in. (152x914 mm), double-acting  
Live heel (rear-mount only) ...5x24 in. (127x610 mm) double acting

Stabilizer ...6x21 in. (152x533 mm), double-acting  
Grapple:

40 in. (1.02 m) and 1/4 cord (0.9 m<sup>3</sup>) ...3-1/2x8 in. (82x203 mm), double-acting  
44 in. (1.12 m) 4x10 in. (102x254 mm), double-acting

### Hydraulic System:

Controls .....2-lever, stack valve  
Relief pressure .....2000 psi (140.6 kg/cm<sup>2</sup>)  
Pump .....60 gpm (227 l/min) at 1800 rpm

#### Reservoir capacity:

Cab mount .....57 gal. (215.8 liters)  
Rear mount .....70 gal. (265 liters)

#### Drive:

Cab mount .....PTO-driven  
Rear mount .....Engine-driven

### Auxiliary Diesel Power Unit: (rear mount only)

John Deere, 4-cylinder, valve-in-head, 4-stroke cycle. Power (@ 2500 rpm), intermittent...70 hp (52 kW\*) 74.4 DIN-PS

Bore and stroke .....4.02x4.33 in. (102x110 mm)

Piston displacement .....219 cu. in. (3589 cm<sup>3</sup>)

Rotation, facing flywheel end .....Counterclockwise

Compression ratio .....16.3 to 1

Alternator .....12 volt, 35 amp w/regulator

Starter .....12 volt (no battery and cables)

\*In the International System of Units (SI), power is expressed in kilowatts (kW).

### Shipping Weight (approx):

Complete with stabilizers, all cylinders, hydraulic pump and all mounting, less grapples:

Cab mount .....7181 lb. (3257 kg)  
Rear mount .....11,776 lb. (5342 kg)

#### Grapples:

40 in. (1.02 m) interlocking .....585 lb. (265 kg)  
44 in. (1.12 m) interlocking .....695 lb. (315 kg)  
1/4 cord (0.9 m<sup>3</sup>) general purpose .....620 lb. (281 kg)

### GRAPPLES

Three types of grapples are available each with the standard orbital motor or a high torque orbital motor.

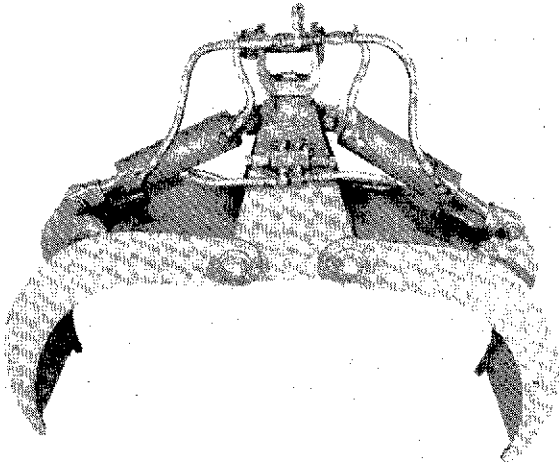

06986Y

Fig. 5-One Quarter Cord Grapple

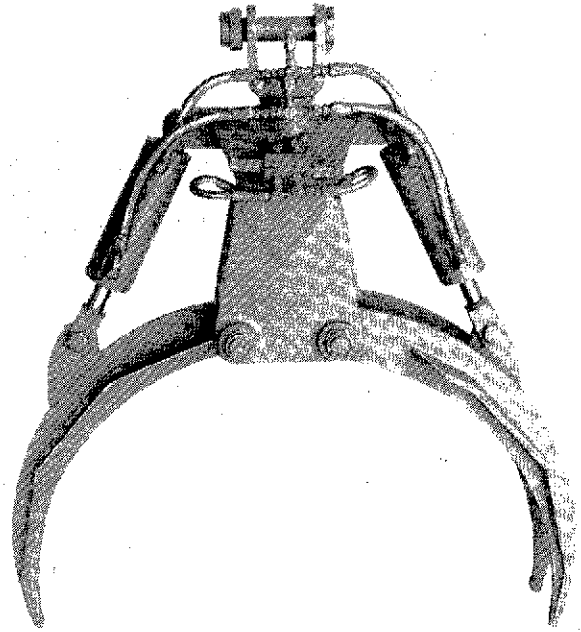

06985Y

Fig. 7-Forty-Inch (1.01 m) Grapple

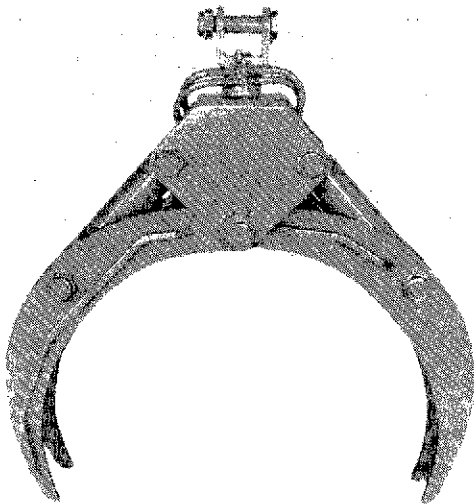

06987Y

Fig. 6-Forty-Four-Inch (1.11 m) Grapple

### BOOM LIFT CAPACITIES (CAB MOUNT AND REAR MOUNT)

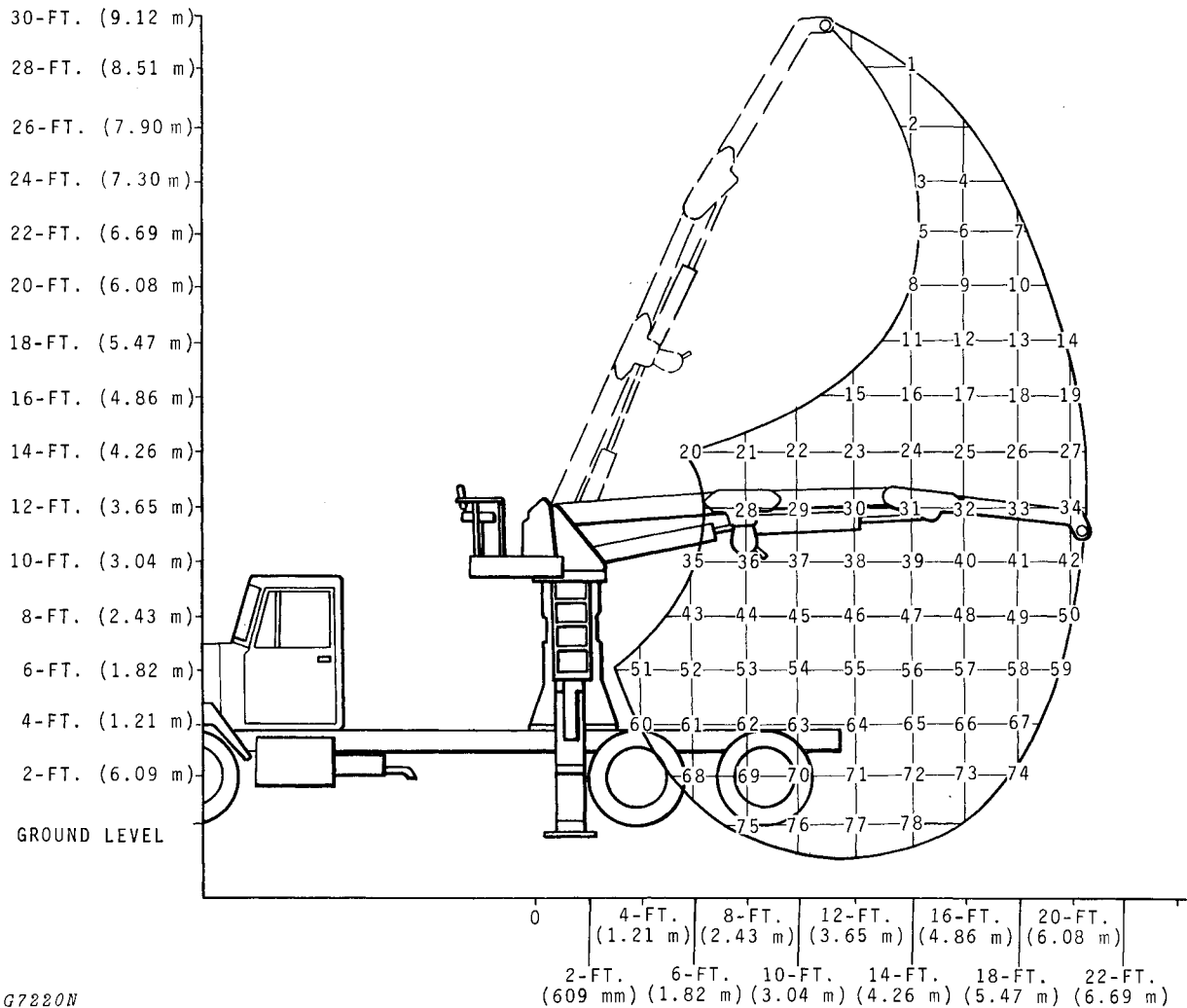

1. 4030 lbs. (17.9 kN)	21. 16670 lbs. (74.2 kN)	41. 8510 lbs. (37.9 kN)	61. 8670 lbs. (38.6 kN)
2. 7330 lbs. (32.6 kN)	22. 13730 lbs. (61.1 kN)	42. 6300 lbs. (28.0 kN)	62. 14890 lbs. (66.2 kN)
3. 7710 lbs. (34.3 kN)	23. 11800 lbs. (52.5 kN)	43. 5610 lbs. (25.0 kN)	63. 14550 lbs. (64.7 kN)
4. 6690 lbs. (22.8 kN)	24. 10410 lbs. (46.3 kN)	44. 14660 lbs. (65.2 kN)	64. 12180 lbs. (54.2 kN)
5. 8170 lbs. (36.3 kN)	25. 9340 lbs. (41.5 kN)	45. 15750 lbs. (70.1 kN)	65. 10290 lbs. (45.8 kN)
6. 7380 lbs. (32.8 kN)	26. 8460 lbs. (36.6 kN)	46. 13070 lbs. (58.1 kN)	66. 8660 lbs. (38.5 kN)
7. 5260 lbs. (23.4 kN)	27. 6370 lbs. (28.3 kN)	47. 11130 lbs. (49.5 kN)	67. 7020 lbs. (31.2 kN)
8. 9000 lbs. (40.0 kN)	28. 18420 lbs. (81.9 kN)	48. 9620 lbs. (42.8 kN)	68. 10600 lbs. (47.2 kN)
9. 7920 lbs. (35.2 kN)	29. 14800 lbs. (65.8 kN)	49. 8310 lbs. (37.0 kN)	69. 14730 lbs. (65.5 kN)
10. 6910 lbs. (30.7 kN)	30. 12460 lbs. (55.4 kN)	50. 5910 lbs. (26.3 kN)	70. 13080 lbs. (58.2 kN)
11. 9510 lbs. (42.3 kN)	31. 10810 lbs. (48.1 kN)	51. 3690 lbs. (16.4 kN)	71. 11010 lbs. (49.0 kN)
12. 8820 lbs. (39.2 kN)	32. 9560 lbs. (42.5 kN)	52. 6940 lbs. (30.9 kN)	72. 9220 lbs. (41.0 kN)
13. 7100 lbs. (31.6 kN)	33. 8530 lbs. (37.9 kN)	53. 13930 lbs. (62.0 kN)	73. 7530 lbs. (33.5 kN)
14. 4020 lbs. (17.9 kN)	34. 6480 lbs. (28.8 kN)	54. 15430 lbs. (68.6 kN)	74. 5370 lbs. (23.9 kN)
15. 11060 lbs. (49.2 kN)	35. 5260 lbs. (23.4 kN)	55. 12850 lbs. (57.2 kN)	75. 12810 lbs. (57.0 kN)
16. 9950 lbs. (44.3 kN)	36. 18460 lbs. (82.1 kN)	56. 10890 lbs. (48.4 kN)	76. 10950 lbs. (48.7 kN)
17. 9070 lbs. (40.3 kN)	37. 15520 lbs. (69.0 kN)	57. 9310 lbs. (41.4 kN)	77. 9220 lbs. (41.0 kN)
18. 7970 lbs. (35.5 kN)	38. 12920 lbs. (57.5 kN)	58. 7870 lbs. (35.0 kN)	78. 7520 lbs. (33.5 kN)
19. 5520 lbs. (24.6 kN)	39. 11080 lbs. (49.3 kN)	59. 4380 lbs. (19.5 kN)	
20. 21700 lbs. (96.5 kN)	40. 9680 lbs. (43.1 kN)	60. 5670 lbs. (25.2 kN)	

These lift values are obtained by use of the boom and jib cylinders and do not account for any additional lift that could be obtained by use of the live heel cylinder for lifting.

Fig. 8-Boom Lift Capacities (Cab Mount and Rear Mount)

### CAB MOUNT SIDE VIEW

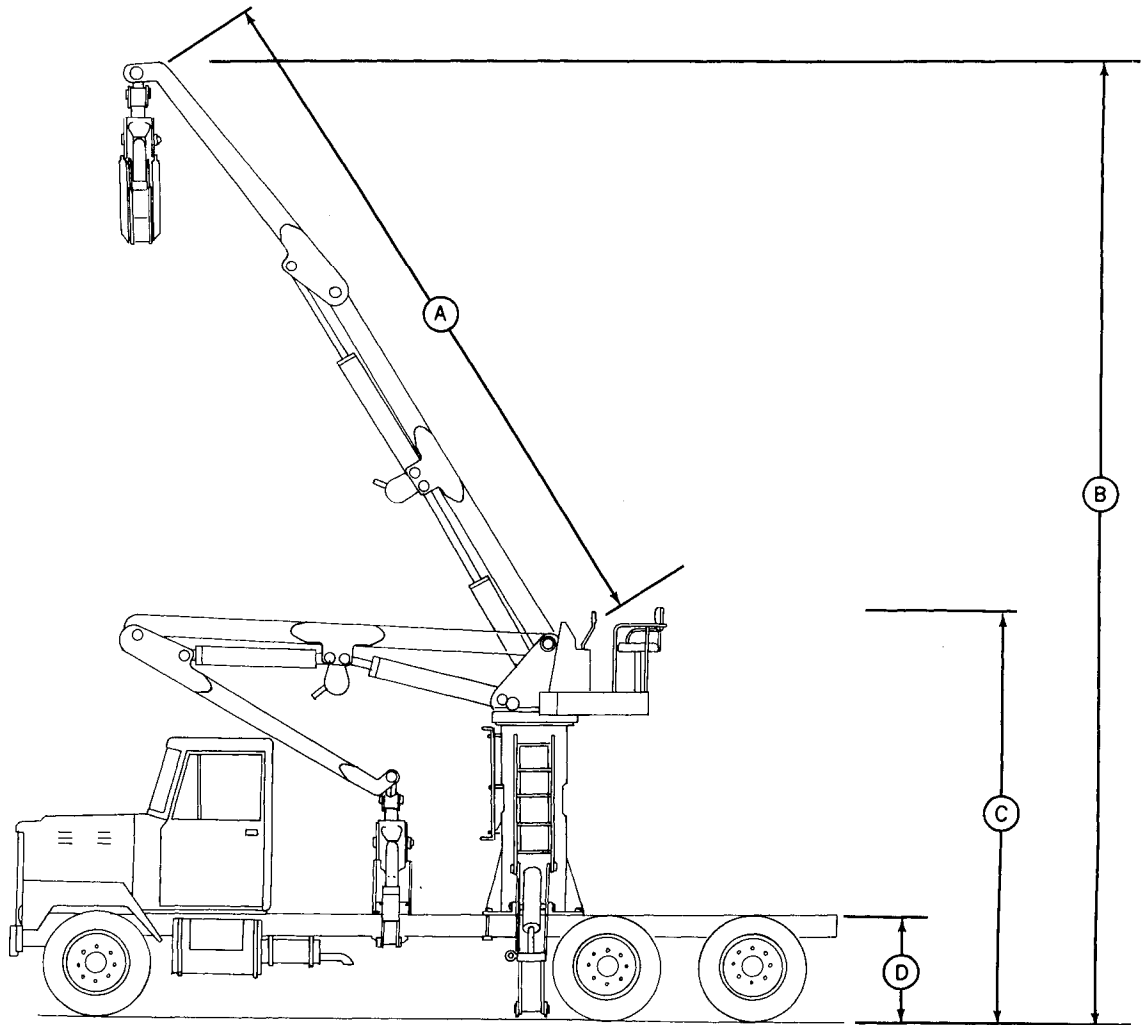

G7217N

A—Boom Length - 21 ft. 6 in. (6.55 m)  
B—Maximum Reach - 31 ft. 8 in. (9.65 m)

C—Transport Height - 13 ft. 2 in. (4.01 m)  
D—Average Truck Bed Height - 3 ft. 6 in. (1.06 m)

Fig. 9-Cab Mount Side View

### REAR MOUNT SIDE VIEW

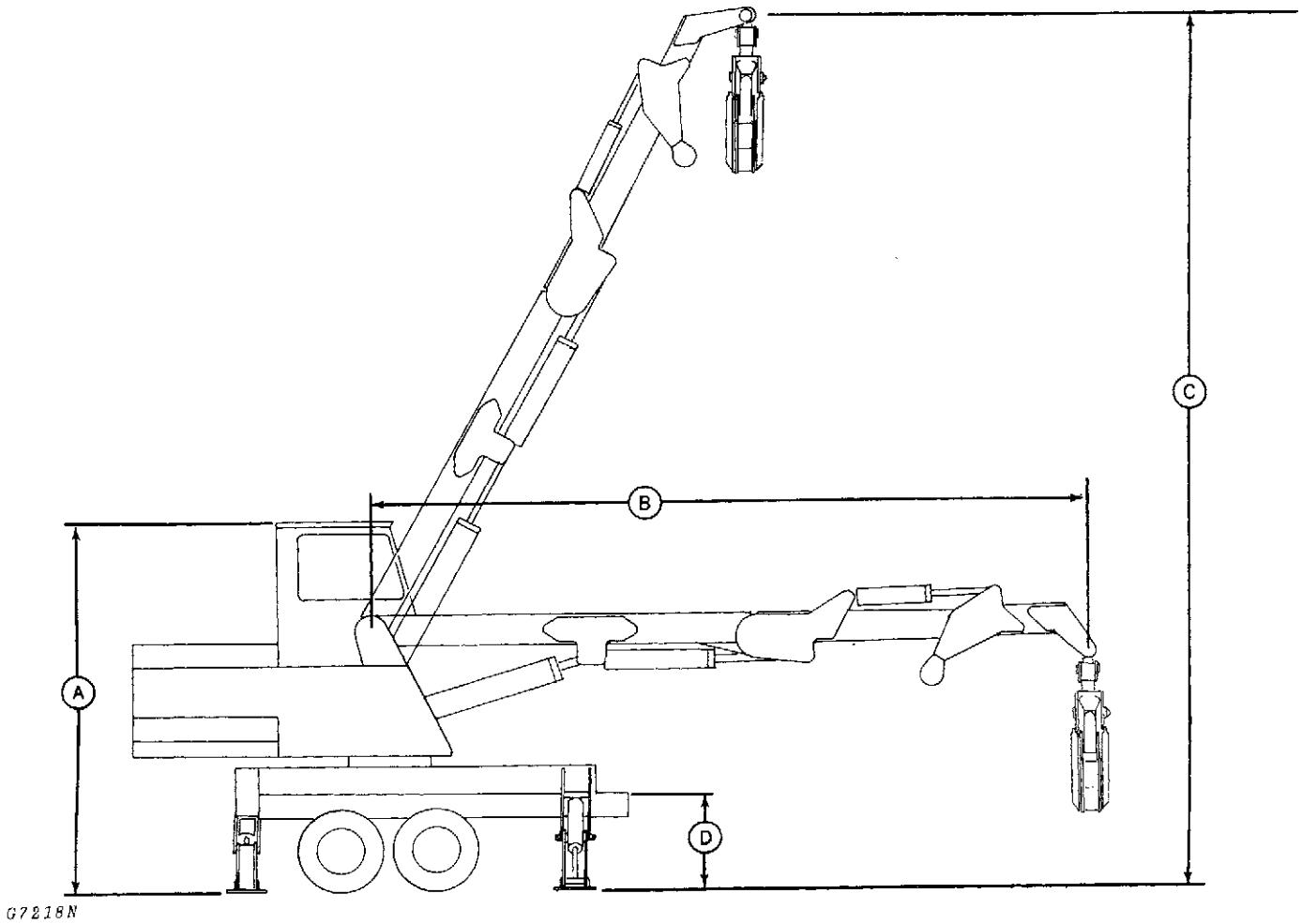

**A**—Transport Height - 13 ft. (3.96 m)  
**B**—Boom Length with Live Heel - 23 ft. (7.01 m)

**C**—Maximum Reach with Live Heel - 28 ft. 10 in. (8.78 m)  
**D**—Average Truck Bed Height - 3 ft. 6 in. (1.06 m)

Fig. 10-7630 (Rear Mount) Side View with Live Heel

### REAR MOUNT REAR VIEW

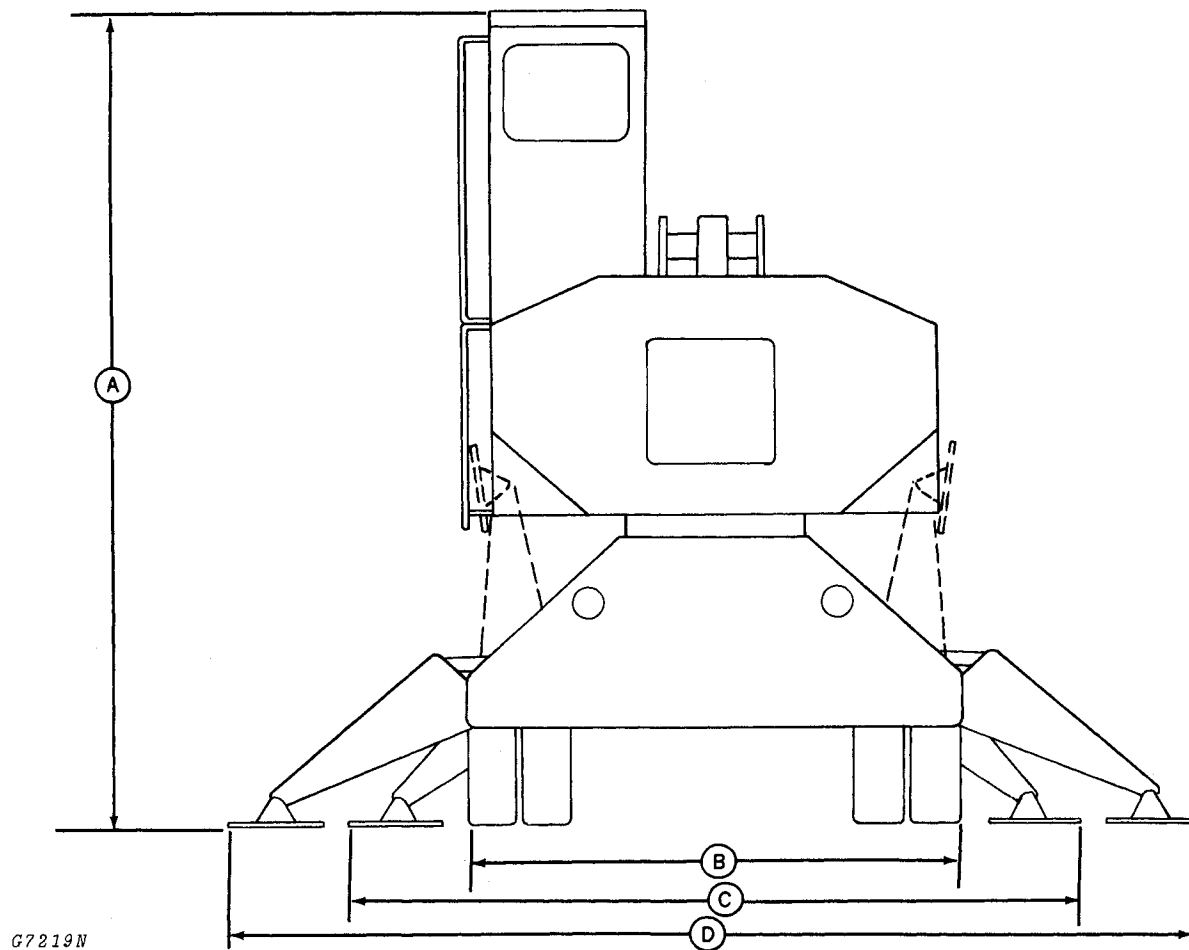

A—Transport Height - 13 ft. (3.96 m)  
B—Average Truck Tread Width - 8 ft. (2.43 m)

C—Front Stabilizer Spread Width - 11 ft. 6 in. (3.5 m)  
D—Rear Stabilizer Spread Width - 15 ft. 4 in. (4.67 m)

Fig. 11-Rear Mount With Live Heel

## Group 10 LUBRICATION

### LUBRICANTS

Effective use of lubricating oils and greases is perhaps the most important step towards low upkeep cost, long engine life, and satisfactory service. Use only lubricants specified in this section; apply them at intervals and according to the instructions in the lubrication and periodic service section.

#### ENGINE LUBRICATING OILS



X3377N

We recommend John Deere Torq-Gard Supreme engine oil for use in the engine crankcase. This oil is compounded specifically for use in John Deere engines and provides superior lubrication under all conditions. NEVER PUT ADDITIVES IN THE CRANKCASE. Torq-Gard Supreme oil is formulated to provide all the protection your engine needs. Additives could reduce this protection rather than help it.

If oil other than Torq-Gard Supreme is used, it must conform to one of the following specifications for all John Deere engines:

##### Single Viscosity Oils

API Service CD/SD  
MIL-L-2104C  
Series 3

##### Multi-Viscosity Oils

API Service CC/SD  
MIL-L-46152

Depending on the expected prevailing temperature for the fill period, use oil viscosity as shown in the following chart.

Air Temperature	John Deere Torq-Gard Oil	Other Oils	
		Single Viscosity Oil	Multi-Viscosity Oil
Above 32°F (0°C)	SAE 30	SAE 30	Not recommended
-10°F to 32°F (-23°C to 0°C)*	SAE 10W-20	SAE 10W	SAE 10W-30
Below -10°F (-23°C)	SAE 5W-20	SAE 5W	SAE 5W-20

\*SAE 5W-20 oil may also be used to insure optimum lubrication at starting, particularly when engine is subjected to -10°F (-23°C) or lower temperatures for several hours.

Some increase in oil consumption may be expected when SAE 5W-20 or SAE 5W oils are used. Check oil level more frequently.

#### STORING LUBRICANTS

Your engine can operate at top efficiency only if clean lubricants are used. Use clean containers to handle all lubricants. Store them in an area protected from dust, moisture, and other contamination.

Do not handicap your engine by using inferior or incorrect oil and grease. Use only quality lubricants at the specified intervals.

#### HYDRAULIC OILS

Use only John Deere Hy-Gard Hydraulic Oil or its equivalent in the hydraulic system reservoir.

For temperatures of 0°F to 30°F (-17.7°C to -1.1°C) use John Deere All Weather Hydrostatic Fluid.

#### GREASES

Use John Deere Multi-Purpose lubricant or an equivalent SAE multipurpose-type grease for all grease fittings. Application of grease as instructed in the lubrication section will provide proper lubrication and will keep loader in top operating condition.

## LUBRICATION AND PERIODIC SERVICE

The instructions on the following pages will help you perform recommended service at proper intervals. Performing the services as instructed will result in long, reliable service.

The intervals at which the various working parts of your knuckleboom should be checked, lubricated, serviced, or adjusted are based on hours of operation.

*NOTE: For engine lubrication refer to the engine operator's manual.*



After the first 50 hours of loader operation change the return line filter in the loader reservoir.

### KEEP LUBRICANTS CLEAN!

Use only high-grade lubricants which have been stored in clean containers. Wipe away all grease and dirt before removing filler caps or plugs.

### LUBRICATION AND SERVICE INTERVALS

The lubrication and service intervals for this knuckleboom are based on operation under average conditions. When the knuckleboom is operated under unusual conditions, such as excessive heat, cold, dust, frequent starts and stops, or with poor quality fuels or lubricants, the knuckleboom should be serviced at MORE FREQUENT INTERVALS.

- #### SYMBOLS
-  Lubricate with John Deere Multi-Purpose Lubricant or an equivalent SAE multipurpose-type grease at hourly intervals indicated on the symbols.
  -  Lubricate Every 10 Hours of Operation with John Deere Hy-Gard Hydraulic Oil or its equivalent.
  -  Oil periodically with John Deere Torq-Gard Supreme Engine Oil or an equivalent SAE 30 oil.

The chart which follows is a condensed list of the knuckleboom components to be serviced at each interval and the service to be performed. Detailed instructions for performing each service are given on the pages which follow the chart. Each item in the chart is numbered, with the corresponding detailed procedure bearing the same number.

Perform the indicated services at the time intervals specified in the chart.

### PERIODIC SERVICE CHART (Cab Mount)

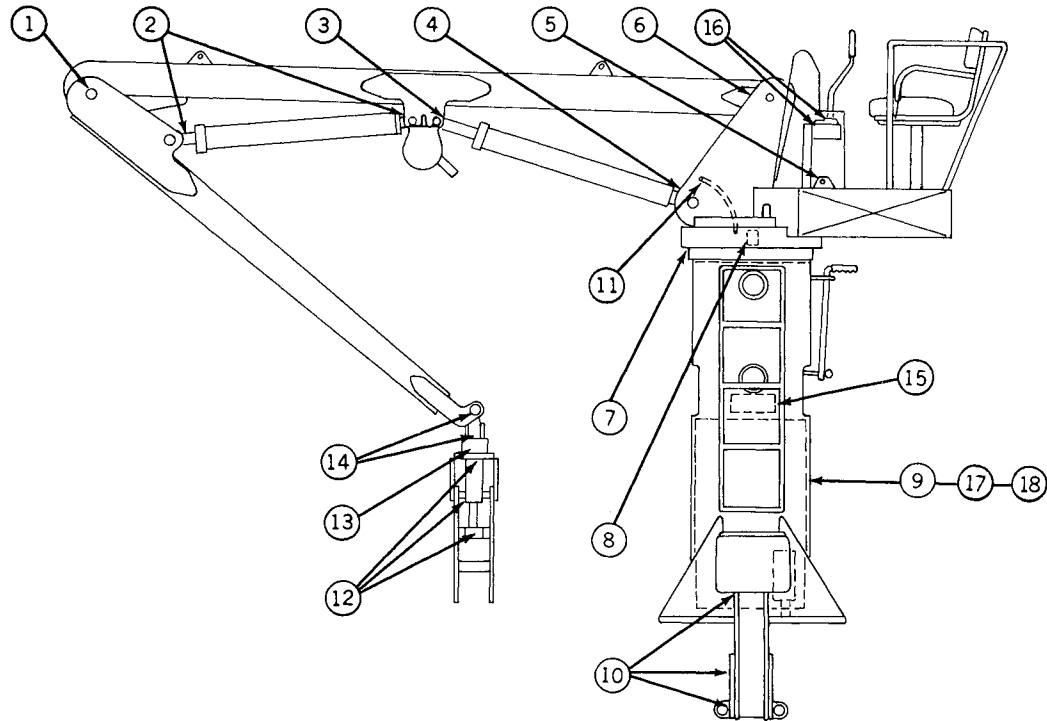

G7170N

Fig. 1-Lubrication Points on Cab Mount

ITEM NO.	INTERVAL HOURS	COMPONENT	SERVICE POINTS	DESCRIPTION OF SERVICE	QUANTITY OF LUBRICANT
1	10 Hours or Daily	Knuckle Bushing	1	Lubricate Grease Fitting	6 Shots*
2		Jib Cylinder Bushings	2	Lubricate Grease Fittings	2 Shots*
3		Main Cylinder Rod Bushing	1	Lubricate Grease Fitting	2 Shots*
4		Main Cylinder Tee Joint	1	Lubricate Grease Fitting	4 Shots*
5		Control Linkage	2	Lubricate Grease Fittings	3 Shots*
6		Main Boom Head Bushing	2	Lubricate Grease Fittings	10 Shots*
7		Ring Gear Teeth	Multi	Grease Gears; Rotate 45°; Grease again; Repeat for 360°	As Needed*
8		Pinion	Multi	Grease Gears; Rotate 45°; Grease Again; Repeat for 360°	As Needed*
9		Hydraulic Reservoir	1	Check Level	4 to 7" (10.16 to 17.19 cm) From Top**
10		Stabilizer Cylinder Bushings and Arm Hinge	6	Lubricate Grease Fittings	2 Shots*
11		Ring Bearing Ball Race	1	Lubricate Grease Fitting	As Needed*
12		Grapple Cylinder Bushings and Arm Hinge	5	Lubricate Grease Fittings	2 Shots*
13		Grapple Heel Bearings	1	Lubricate Grease Fitting	4 Shots*
14		Bucket Cross	2	Lubricate Grease Fittings	2 Shots*
15	100 Hours	Return Line Filter	1	Replace Filter Element	As Needed
16	Control Linkage	Multi	Oil Lightly	As Needed***	
17	500 Hours	Hydraulic Reservoir	1	Drain, Clean, and Refill	57 Gal. (213.4 l)**
18	or Twice Yearly	Suction Screen	2	Clean	****

\*Lubricate with John Deere Multi-Purpose Lubricant or its equivalent

\*\*Lubricate with John Deere Hy-Gard Hydraulic Oil or its equivalent

\*\*\*Lubricate with John Deere Torq-Gard Supreme Engine Oil or its equivalent

\*\*\*\*Clean with diesel fuel or kerosene

(CAB MOUNT)  
EVERY 10 HOURS OR DAILY

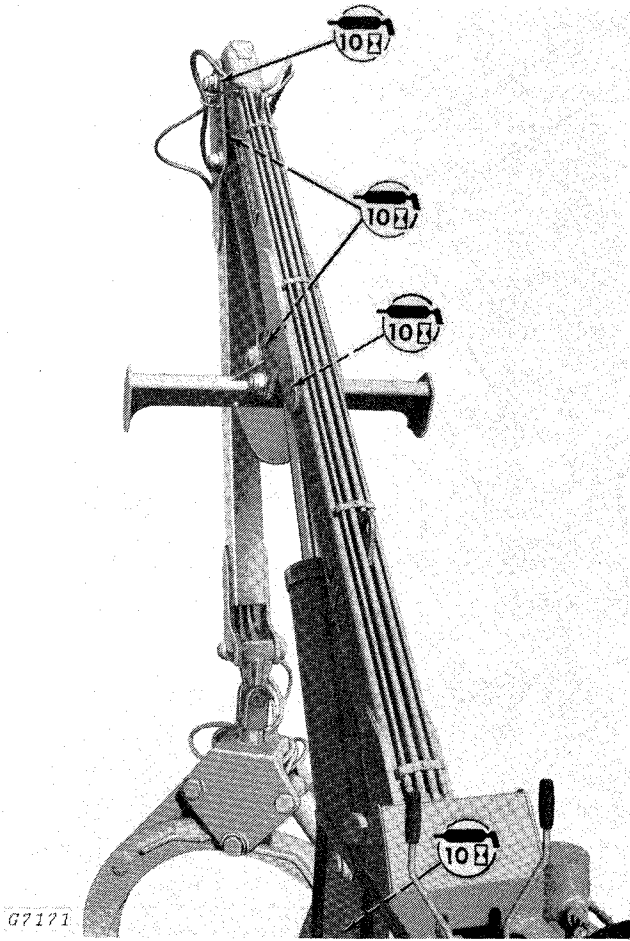

Fig. 2-Bushing Lubrication

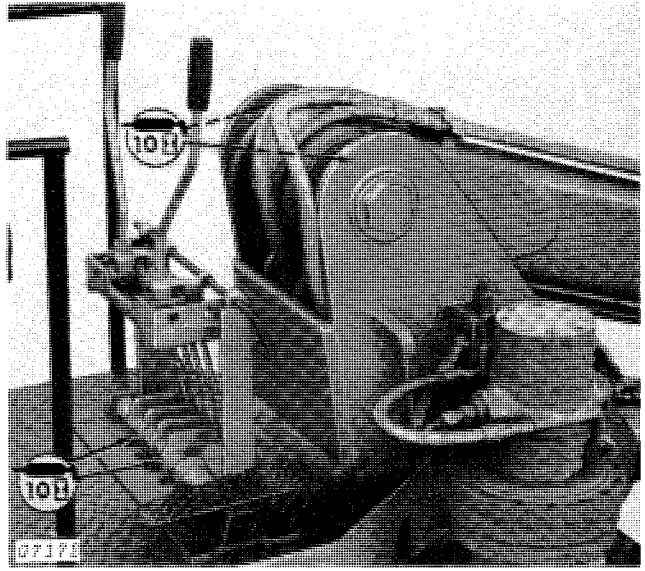

Fig. 3-Control Linkage Lubrication

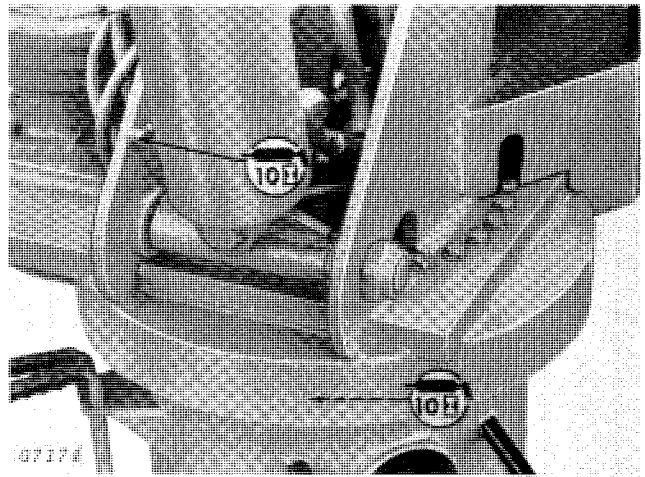

Fig. 4-Pinion Gear

(CAB MOUNT) EVERY 10 HOURS OR DAILY—Continued

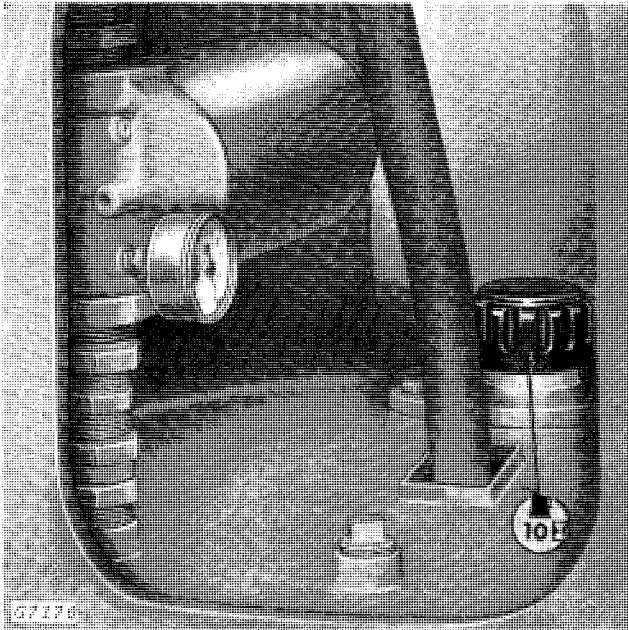

Fig. 5-Hydraulic Reservoir

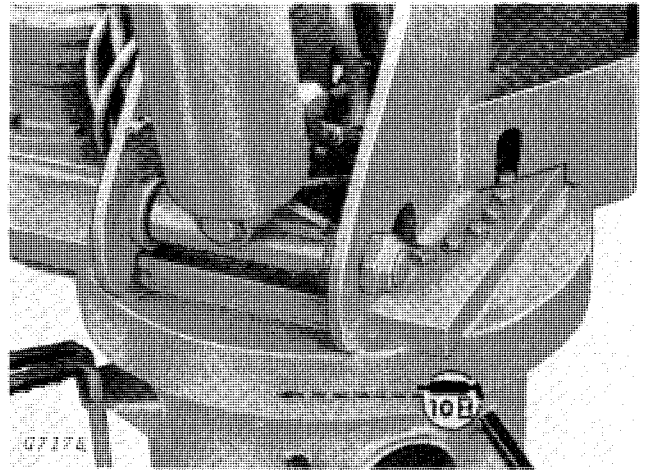

Fig. 7-Ring Bearing Ball Race

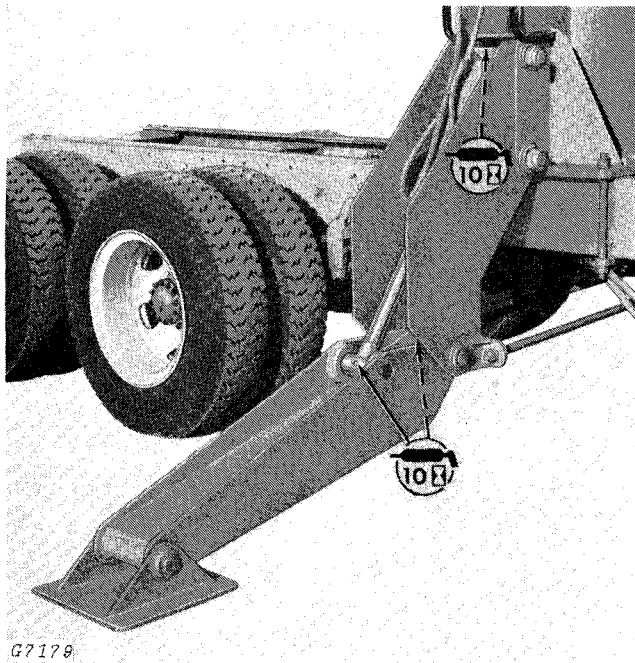

Fig. 6-Stabilizer Fittings

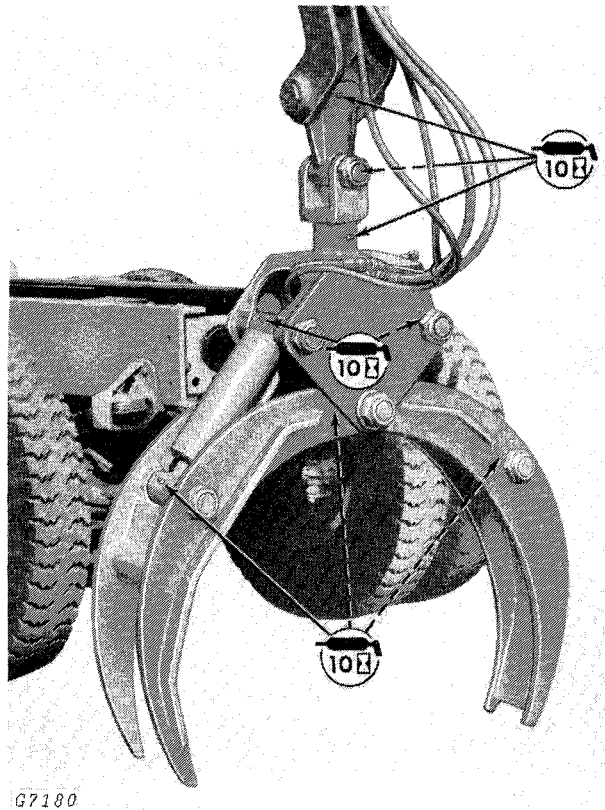

Fig. 8-Grapple

**(CAB MOUNT)  
EVERY 100 HOURS**

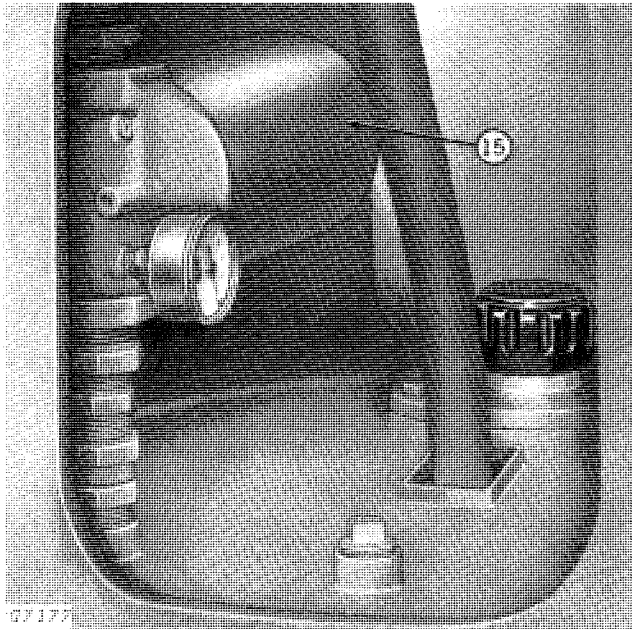

Fig. 9-Return Line Filter

**(CAB MOUNT)  
EVERY 500 HOURS**

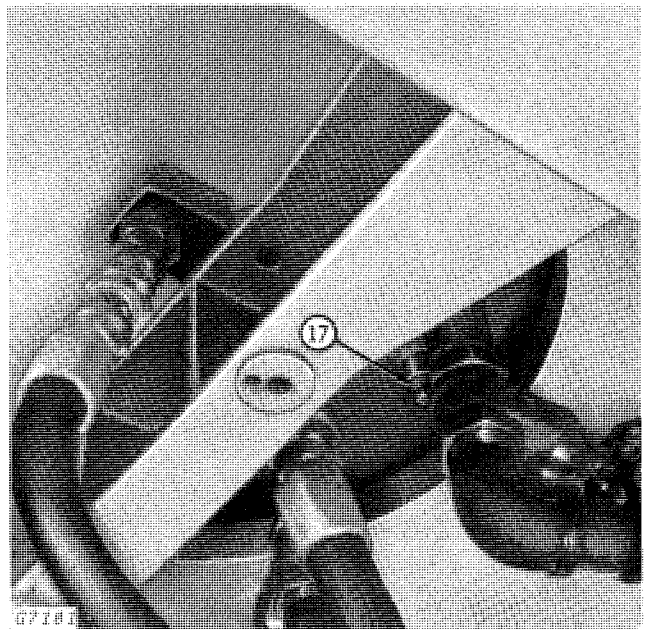

Fig. 11-Hydraulic Reservoir

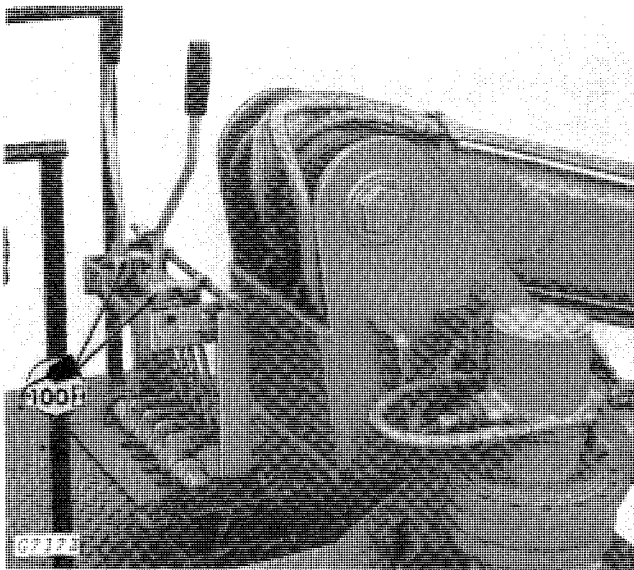

Fig. 10-Control Linkage

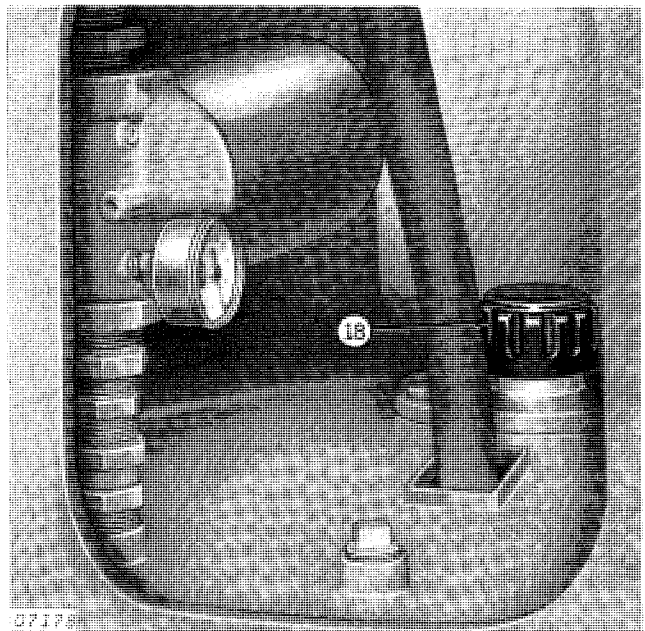
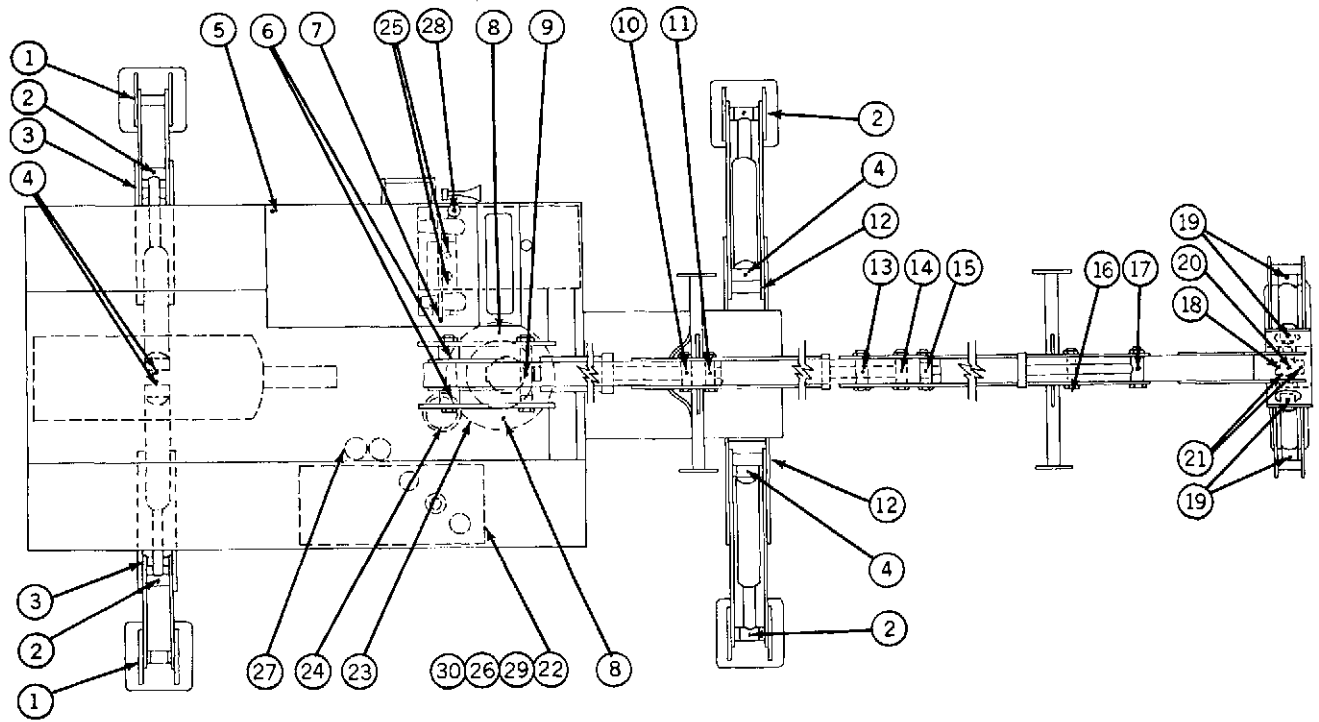

Fig. 12-Suction Screen

### PERIODIC SERVICE CHART (REAR MOUNT)



G7182N

Fig. 13-Lubrication Points on 7630 Rear Mount Knuckleboom Loader

ITEM NO.	INTERVAL HOURS	COMPONENT	SERVICE POINTS	DESCRIPTION OF SERVICE	QUANTITY OF LUBRICANT
1	10 or Daily	Rear Stabilizer Pad Hinge	2	Lubricate Grease Fittings	2 Shots*
2		Stabilizer Cylinder Rod Bushings	4	Lubricate Grease Fittings	2 Shots*
3		Rear Stabilizer Arm Hinge	2	Lubricate Grease Fittings	2 Shots*
4		Stabilizer Cylinder Tee Joints	4	Lubricate Grease Fittings	2 Shots*
5		Cab Door Catch	1	Lubricate Grease Fitting	Grease Lightly*
6		Main Boom Head Bushing†	2	Lubricate Grease Fittings	10 Shots*
7		Control Linkage	2	Lubricate Grease Fittings	3 Shots*
8		Turntable Bearing Ball Race	2	Lubricate Grease Fittings	As Needed*
9		Main Cylinder Tee Joint	1	Lubricate Grease Fittings	4 Shots*
10		Main Cylinder Rod Bushing	1	Lubricate Grease Fitting	2 Shots*
11		Jib Cylinder Tee Joint	1	Lubricate Grease Fitting	2 Shots*
12		Front Stabilizer Arm Hinge	2	Lubricate Grease Fittings	2 Shots*
13		Knuckle Bushing†	1	Lubricate Grease Fitting	6 Shots*
14		Jib Cylinder Rod Bushing	1	Lubricate Grease Fitting	2 Shots*
15		Heel Cylinder Tee Joint	1	Lubricate Grease Fitting	2 Shots*
16		Jib and Heel Hinge	1	Lubricate Grease Fitting	6 Shots*
17		Heel Cylinder Rod Bushing	1	Lubricate Grease Fitting	2 Shots*
18		Grapple Heel Bearings†	1	Lubricate Grease Fitting	4 Shots*
19		Grapple Cylinder Bushings	4	Lubricate Grease Fittings	2 Shots*
20		Grapple Cylinder Arm Hinge	1	Lubricate Grease Fitting	2 Shots*
21		Bucket Cross	2	Lubricate Grease Fittings	2 Shots*
22		Hydraulic Reservoir	1	Check Level	4 to 7" (10.16 to 17.78 cm) from top**
23	Turntable Gear Teeth†	Multi	Grease Gears; Rotate 45°; Grease Again; Repeat for 360°	As Needed*	
24	Pinion Gear†		Grease Gears; Rotate 45°; Grease Again; Repeat for 360°	As Needed*	
25	100	Control Linkage	Multi	Oil Lightly	As Needed***
26		Suction Line Filters††	3	Replace Elements	As Needed
27		Return Line Filters	2	Replace Elements	As Needed
28	500 or Twice Yearly	Air Horn Compressor	1	Oil Lightly	2 Drops***
29		Hydraulic Reservoir†††	1	Drain, Clean and Refill	88 Gals. (264 l)****††
30		Suction Screen	2	Clean	****

\*Lubricate with John Deere Multi-Purpose Lubricant or its equivalent  
 \*\*Lubricate with John Deere Hy-Gard Hydraulic Oil or its equivalent  
 \*\*\*Lubricate with John Deere Torq-Gard Supreme Engine Oil or its equivalent  
 \*\*\*\*Clean with diesel fuel or kerosene

†Grease Every 5 Hours Under Adverse Conditions  
 ††Change Filters After First 50 Hours and 50 Hours After Each Major Hydraulic System Repair  
 †††For Temperature of 0°F to 30°F (-17.7°C to -1.1°C) Use John Deere All Weather Hydrostatic Fluid or its equivalent

(REAR MOUNT)  
EVERY 10 HOURS OR DAILY

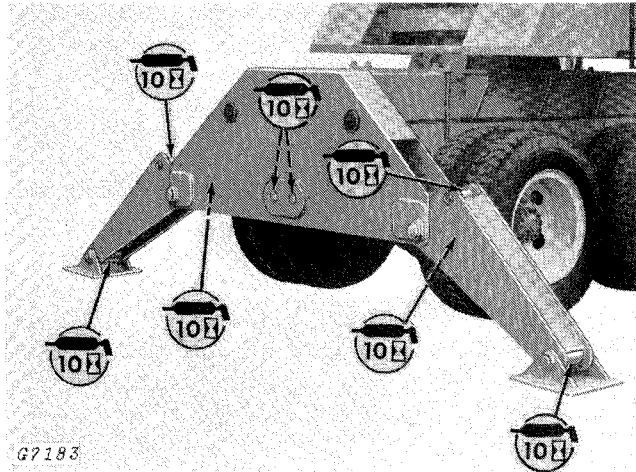

Fig. 14-Rear Stabilizer

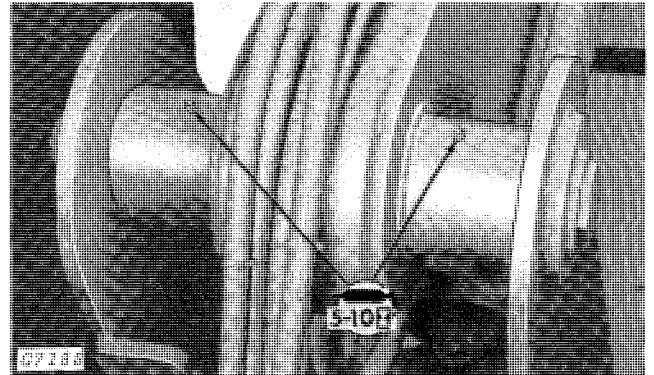

Fig. 16-Head Bushing

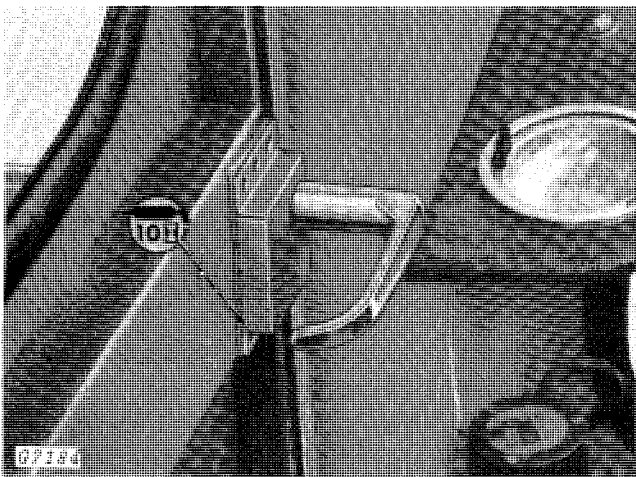

Fig. 15-Door Latch

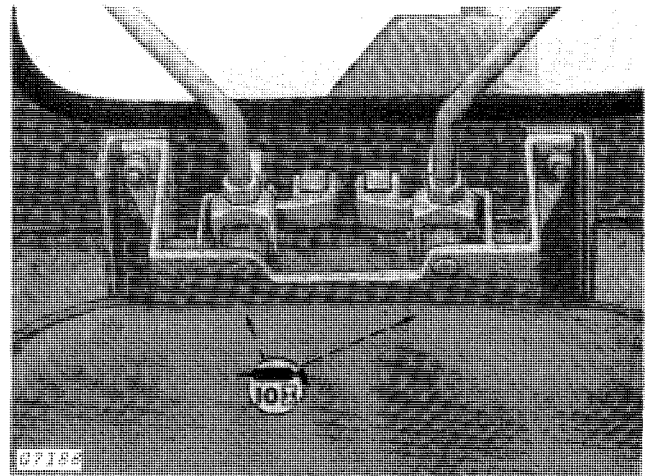

Fig. 17-Control Linkage



**Suggest:**

**If the above button click is invalid.**

**Please download this document**

**first, and then click the above link**

**to download the complete manual.**

**Thank you so much for reading**

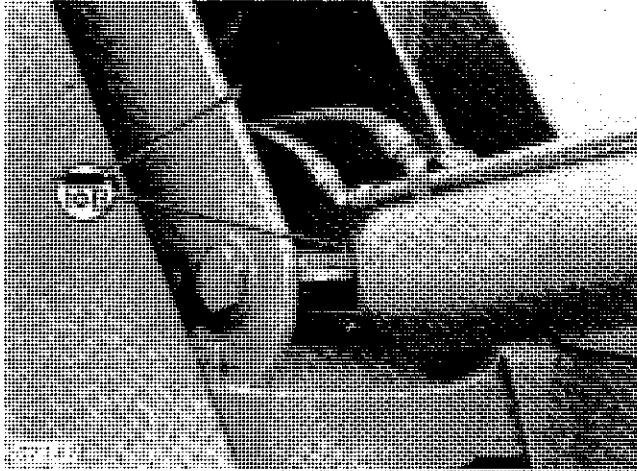

Fig. 18-Head

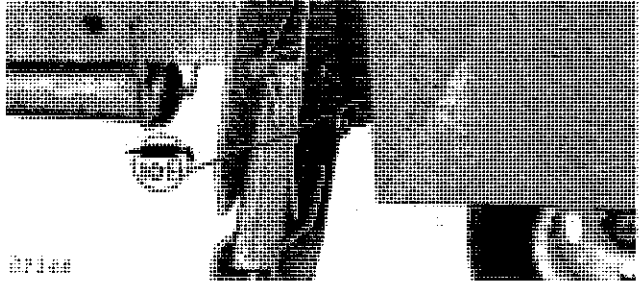

Fig. 20-Stabilizer Arm Hinge

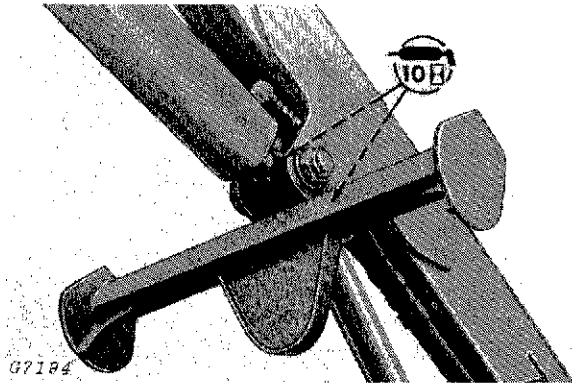

Fig. 19-Main and Jib Cylinder

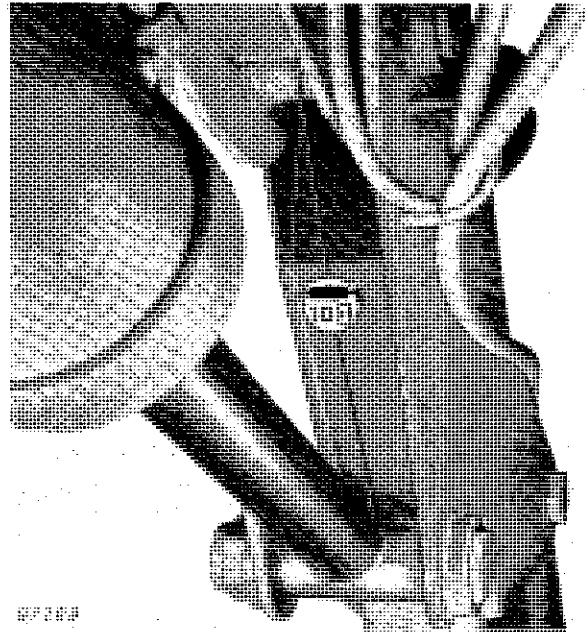

Fig. 21-Knuckle and Jib Bushings

**<https://www.ebooklibonline.com>**

Hello dear friend!

Thank you very much for reading.

Enter the link into your browser.

The full manual is available for immediate download.

**<https://www.ebooklibonline.com>**