



7520 Tractor



JOHN DEERE

TECHNICAL MANUAL 7520 Tractor

TM1053 (01FEB78) English

TM1053 (01FEB78)

LITHO IN U.S.A. (REVISED)
ENGLISH



7520 TRACTOR TECHNICAL MANUAL TM-1053 (Jan-72)

CONTENTS

SECTION 10 - GENERAL

- Group 5 - General Tractor Specifications
- Group 10 - Predelivery, Delivery, and After-Sale Services
- Group 15 - Tune-Up
- Group 20 - Lubrication
- Group 25 - Separation
- Group 30 - Torques and Special Tools

SECTION 20 - ENGINE

- Group 5 - General Information, Diagnosis, and Tests
- Group 10 - Cylinder Head, Valve Train, and Camshaft
- Group 15 - Cylinder Block, Liners, Pistons, and Rods
- Group 20 - Crankshaft, Main Bearings, and Flywheel
- Group 25 - Lubrication System
- Group 30 - Cooling System
- Group 35 - Specifications

SECTION 30 - FUEL SYSTEM

- Group 5 - Diagnosing Malfunctions
- Group 10 - Air Intake System
- Group 15 - Fuel Injection System
- Group 20 - Speed Control Adjustment
- Group 25 - Specifications

SECTION 40 - ELECTRICAL SYSTEM

- Group 5 - Information and Wiring Diagrams
- Group 10 - Motorola Charging Circuit
- Group 15 - Delcotron Charging Circuit
- Group 20 - Starting Circuit
- Group 25 - Lighting and Accessory Circuits
- Group 30 - Specifications

SECTION 50 - POWER TRAIN

- Group 5 - Clutch
- Group 10 - Torque Divider
- Group 15 - Syncro-Range Transmission
- Group 20 - Differentials
- Group 25 - Final Drives
- Group 30 - PTO
- Group 35 - Specifications

SECTION 60 - STEERING AND BRAKES

- Group 5 - General Information

SECTION 70 - HYDRAULIC SYSTEM

- Group 5 - General Information, Diagnosis, and Tests
- Group 10 - Main Reservoir, Filters, Valves, Oil Cooler, and Oil Reservoir
- Group 15 - Hydraulic Pumps
- Group 20 - Power Steering
- Group 25 - Power Brakes
- Group 30 - Selective Control Valve, Breakaway Couplers, and Remote Cylinders
- Group 35 - Specifications

SECTION 80 - MISCELLANEOUS

- Group 5 - Hinge Assembly

All information, illustrations and specifications contained in this technical manual are based on the latest information available at the time of publication. The right is reserved to make changes at any time without notice.

Copyright© 1972
DEERE & COMPANY
Moline, Illinois
All rights reserved

INTRODUCTION

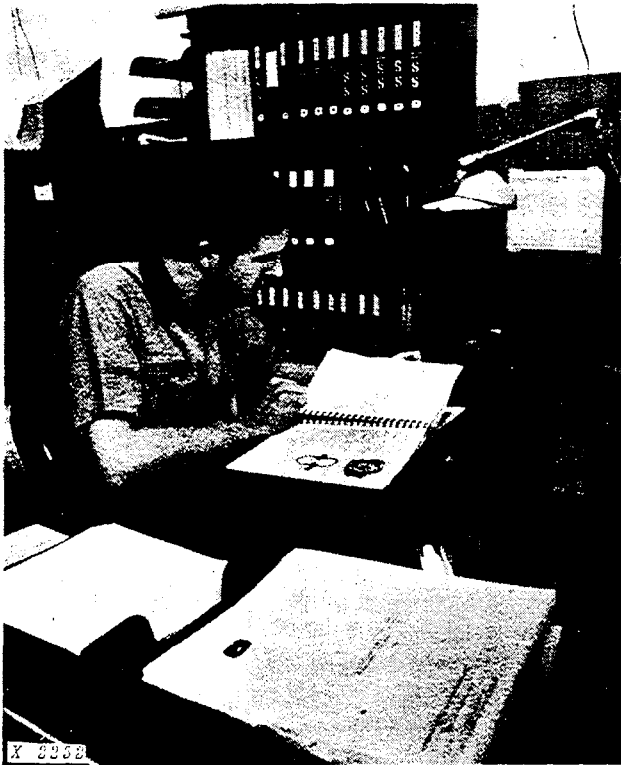

Use FOS Manuals for Reference



Use Technical Manuals for Actual Service

This technical manual is part of a twin concept of service:

- **FOS Manuals—**for reference
- **Technical Manuals—**for actual service

The two kinds of manuals work as a team to give you both the general background and technical details of shop service.

Fundamentals of Service (FOS) Manuals cover basic theory of operation, *fundamentals* of trouble shooting, *general* maintenance, and *basic* types of failures and their causes. FOS Manuals are for training new men and for reference by experienced men.

Technical Manuals are concise service guides for a specific machine. Technical Manuals are on-the-job guides containing only the vital information needed by a journeyman mechanic.



When a serviceman should refer to a FOS Manual for more information, a FOS symbol like the one at the left is used in the TM to identify the reference.

Some features of this technical manual:

- *Table of contents at front of manual*
- *Exploded views showing parts relationship*
- *Photos showing service techniques*
- *Specifications grouped for easy reference*

This technical manual was planned and written for you—a journeyman mechanic. Keep it in a permanent binder in the shop where it is handy. Refer to it whenever in doubt about correct service procedures or specifications.

Using the technical manual as a guide will reduce error and costly delay. It will also assure you the best in finished service work.



This safety alert symbol identifies important safety messages in this manual. When you see this symbol, be alert to the possibility of personal injury and carefully read the message that follows.

<https://www.ebooklibonline.com>

Hello dear friend!

Thank you very much for reading.

Enter the link into your browser.

The full manual is available for immediate download.

<https://www.ebooklibonline.com>

Transmission:

Type Syncro-Range, constant mesh
Clutch Heavy-duty, 13-1/2 in. dual plate, hydraulic assist, foot operated
Gear selections 8 forward and 2 reverse
Shifting ... Two lever shifting, synchronized shifting within stations, except reverse gears; Optional "Hi-Lo" speed selector provides two speeds in each gear for 16 forward and 4 reverse.

Ground Speeds (in miles per hour, 2100 engine rpm)*

Gear	"Lo"	"Hi"
1st	2.08	2.39
2nd	3.33	3.82
3rd	4.39	5.04
4th	5.64	6.48
5th	7.02	8.07
6th	9.20	10.58
7th	11.91	13.70
8th	19.44	22.35
1st reverse	4.27	4.91
2nd	6.84	7.86

Electrical System:

Type 12-volt, negative grounded
Batteries Two, 6-volt, 87-plate, 204-ampere-hour, 7D type, connected in series
Alternator 12-volt, with transistorized regulator; 55 amp without air conditioning; 72 amp with air conditioning

Power Take-Off:

Type Transmission-driven
Speed
1800 engine rpm in "Hi" 1000 rpm
2100 engine rpm in "Lo" or with standard 8-speed transmission 1000 rpm
PTO ahead of drawbar hitch point 20 in.

Hydraulic System:

Type Closed center, constant pressure. Includes power steering, power brakes, implement control, and transmission and differential lubrication
Standby pressure 2250 psi

Brakes Hydraulically power-actuated disk-type operating in oil
Tires* * 23.1-30, 8-ply rating

Wheel Tread: See operator's manual

Dimensions:

Wheel base 125 in.
Over-all length 220 in.
Over-all height 123 in.
-With air conditioner 131 in.

Over-all width 95-7/8 in.
-long-axle-114 in.

Turning radius (80-in. tread) 220 in.

Shipping Weight (With equipment for average field service, less fuel and ballast) 16,790 lbs.

* * Additional tire sizes available

* Ground speeds for tractors with standard 8-speed transmission are the same as "Lo."

(Specifications and design subject to change without notice.)

Group 10 PREDELIVERY, DELIVERY AND AFTER-SALE SERVICE

PREDELIVERY SERVICE

Because of the shipping factors involved, plus extra finishing touches that are necessary, to promote customer satisfaction, proper predelivery service is of prime importance to the dealer.

A tag pointing out the factory-recommended procedure for predelivery service is attached to each new tractor before it leaves the factory.

After completing the factory-recommended dealer checks and services listed on the predelivery tag, remove the tag from the tractor and file it with the shop order for the job. The tag will certify that the tractor has received the proper predelivery service when the portion of the customer's John Deere Delivery Receipt is completed.

NOTE: A Caplug is placed in the muffler outlet to prevent turbocharger rotation during transit. Remove Caplug before unloading tractor. Reinstall Caplug before transporting the tractor to the customer.

Temporary Tractor Storage

Service	Specification	Reference
Check radiator for coolant loss and antifreeze protection	Within 3/4-in. from bottom of filler neck.
Reduce shipping pressure of tires	Operator's manual
Cover tractor and tires for protection and cleanliness

Before Delivering Tractor

ELECTRICAL SYSTEM		
Install electrolyte and charge batteries	FOS - 20 Manual
Date code battery warranty tag	FOS - 20 Manual
Connect Motorola alternator. Do not attempt to polarize	Section 40, Group 10
Install light switch knob
Clean terminals and connect battery cables	Section 40, Group 5
Check alternator belt adjustment	1-inch deflection, 25 lb. force.	Operator's manual
COOLING SYSTEM		
Inspect radiator for coolant loss	Within 3/4-in. from bottom of filler neck.
Check antifreeze protection

Before Delivering Tractor—Continued

Service	Specification	Reference
TIRES AND WHEELS		
Adjust pressure of tires	Operator's manual
Check wheel rim clamp nuts, and wheel retainer cap screws for tightness	Retainer cap screws-300 ft-lbs Rim clamp nuts-170 ft-lbs
Set front and rear wheel tread to a minimum of 80 in., and add at least 1,000 lb. ballast to each wheel for single wheel operation	Operator's manual
Hillside operation—use double wheels only	Operator's manual
LUBRICATION		
Check crankcase oil level	To upper marks on dipstick	Operator's manual
Check transmission-hydraulic system oil level	To top of "SAFE" range on dipstick. Type 303 Special-Purpose Oil	Operator's manual
Check front differential oil level	To level of filler plug opening. Type 303 Special-Purpose Oil.	Operator's manual
Lubricate grease fittings	John Deere Multipurpose Lubricant	Operator's manual
ENGINE		
Check air cleaner	Operator's manual
Fill fuel tank and start engine	Capacity - 78 U.S. gallons each tank	Operator's manual
Check operation of starter, alternator, flasher, gauges, and indicator lights	Operator's manual
Check engine timing	27° BTDC	Section 30, Group 15
Check engine speeds	800 rpm, slow idle speed 2300 rpm fast idle speed and max. transport speed	Section 30, Group 15

Before Delivering Tractor—Continued

Service	Specification	Reference
OPERATION		
Check transmission clutch free travel	Approximately 1-11/16 inches free travel (engine at fast idle)	Operator's manual
Shift transmission through all Speeds	Operator's manual
Check throttle linkage for free operation	Section 30, Group 20
Adjust headlights and check operation	Operator's manual
Check power takeoff operation	Operator's manual
Check brakes and accumulator	3 in. maximum travel when brakes have been bled, and accumulator is working properly.	Operator's manual
Check air conditioning, heater, and pressurizer operation	Operator's manual
Check hydraulic system operation; steering, rockshaft, and remote cylinder	Operator's manual
Check seat operation	Operator's manual
GENERAL		
Tighten accessible nuts and cap screws
Clean tractor and touch up paint

DELIVERY SERVICE

A thorough discussion of the operation and service of a new tractor at the time of delivery helps to assure complete customer satisfaction. Proper delivery should be an important phase of a dealer's program. A portion of the John Deere Delivery Receipt emphasizes the importance of proper delivery service.

Many complaints have arisen simply because the owner was not shown how to operate and service his new tractor properly. Spend enough time, at the customer's convenience, to introduce the owner to his new tractor and explain to him how to operate and service it properly.

IMPORTANT: Install Caplug in muffler outlet if transporting tractor to customer. This will prevent damage to the turbocharger caused by air passing through the turbocharger and rotating it without lubrication when the engine is stopped.

The following procedure is recommended before the serviceman and owner complete the delivery acknowledgments portion of the delivery receipt.

Using the tractor operator's manual as a guide, be sure that the owner understands these points thoroughly:

1. Controls and instruments.
2. How to start and stop the engine.
3. The importance of the break-in period.
4. How to use liquid or cast-iron ballast.
5. All functions of the hydraulic system.
6. Using the power takeoff.
7. The importance of safety.
8. The importance of lubrication and periodic services.

After explaining and demonstrating the above features, have the owner sign the delivery receipt and give him the operator's manual.

AFTER-SALE INSPECTION

The purchaser of a new John Deere tractor is entitled to a free inspection within the warranty period after the equipment has been "run in." The terms of this after-sale inspection are outlined on the back of the John Deere Delivery Receipt.

The purpose of this inspection is to make sure that the customer is receiving satisfactory performance from his tractor. At the same time, the inspection should reveal whether or not the tractor is being operated, lubricated, and serviced properly.

If the recommended after-sale service inspection is followed, the dealer can eliminate a needless volume of service work by preventing minor irregularities from developing into serious problems later on. This will promote strong dealer-customer relations and present the dealer an opportunity to answer questions that may have arisen during the first few days of operation. During the inspection service, the dealer has the further opportunity of promoting the possible sale of other new equipment.

The following inspection program is recommended within the first 100 hours of tractor operation.

Inspection Procedure

Service	Specification	Reference
COOLING SYSTEM		
Check radiator coolant level	Within 3/4-in. from bottom of filler neck.
Clean external surface of radiator core
Check hoses and connections for leaks
FUEL SYSTEM		
Remove water and foreign matter from filter sediment bowl	Operator's manual
Bleed fuel system	Operator's manual
Tighten loose connections and check entire system for leaks, correct if necessary
Check air cleaner element, and unloading valve. Clean element if necessary	Operator's manual
ELECTRICAL SYSTEM		
Check specific gravity of batteries ...	Full charge - 1.260 at 80°F.	Operator's manual
Check level of battery electrolyte	To bottom of filler neck in each cell	Operator's manual
Check belt tension	1-inch deflection with a 25-pound force	Operator's manual



Inspection Procedure—Continued

Service	Specification	Reference
Start engine and check operation of starter, lights, and indicator lamps	Operator's manual
LUBRICATION		
Check crankcase oil level	To upper marks on dipstick	Operator's manual
Check transmission-hydraulic system oil level	In "SAFE" range on dipstick. Use John Deere Type 303 Special-Purpose Oil	Operator's manual
Check front differential oil level	To level with filler plug opening Use John Deere Type 303 Special-Purpose Oil	Operator's manual
ENGINE		
Check valve clearance	Intake: 0.018-inch	Operator's manual
Check engine speed under load, fuel consumption, and horsepower	Exhaust: 0.028-inch	Operator's manual
Check engine speed under load, fuel consumption, and horsepower	Specification	Group 15 of this Section.
TRACTOR AND POWER TRAIN		
Check transmission clutch free travel	Approximately 1-11/16 inches free travel (engine at fast idle)	Operator's manual
Shift transmission through all speeds	Operator's manual
Check power steering	Smooth, easy operation	Section 70, Group 20
Check brakes and accumulator	3 inches maximum brake travel when brakes have been bled and accumulator is working properly.	Operator's manual

Inspection Procedure—Continued

Service	Specification	Reference
HYDRAULIC SYSTEM		
Check rockshaft and remote cylinder operation	Section 70, Group 30
Reverse signal lockout	Section 70, Group 30
Check entire tractor for leaks. Inspect drive shafts, hydraulic system pipes and hoses, and check tractor cab controls for proper operation	Operator's manual
NUTS AND CAP SCREWS		
Tighten accessible nuts and cap screws that seem to require adjustment

TORQUE CHART (ft-lbs)

Bolt Diameter	 Plain Head*	 Three Radial Dashes*	 Six Radial Dashes*
1/4	6	10	14
5/16	13	20	30
3/8	23	35	50
7/16	35	55	80
1/2	55	85	120
9/16	75	130	175
5/8	105	170	240
3/4	185	300	425
7/8	160* *	445	685
1	250* *	670	1030

* The types of bolts and cap screws are identified by head markings as follows:

Plain Head: regular machine bolts and cap screws.

3-Dash Head: tempered steel high-strength bolts and cap screws.

6-Dash Head: tempered steel extra high-strength bolts and cap screws.

** Machine bolts and cap screws 7/8-inch and larger are sometimes formed hot rather than cold, which accounts for the lower torque.

Group 15

TUNE-UP

Before tuning up a tractor, determine whether a tune-up will restore operating efficiency. When there is doubt, the following preliminary tests will help to determine if the engine can be tuned up. If the condi-

tion is satisfactory, proceed with the tune-up. Choose from the following procedures only those necessary to restore the unit.

Preliminary Engine Testing

Operation	Specification	Section-Group Reference
Dynamometer Test (at 2100 engine rpm full load) . . .	Compare with previous recorded output; compare with output after tune-up	FOS - 30 Manual, Chapter 12
Compression Test	330-380 at 200-250 rpm	FOS - 30 Manual, Chapter 12
Engine Coolant Check Test	No air bubbles or oil film in radiator	FOS - 30 Manual, Chapter 12

Engine Tune-up

Operation	Specification	Section-Group Reference
Air Intake System Service air cleaner and check system for leaks	FOS - 30 Manual, Chapter 12
Check system for restrictions using water manometer	FOS - 30 Manual, Chapter 12
Normal reading, inches of water (with clean filter elements) . .	16 in. at 2100 rpm (full load)
Maximum permitted reading . .	25 in. at 2100 rpm (full load)
Check restriction indicator light operation	24-26 in. at 2100 rpm (full load)
Exhaust System Check system for leaks	FOS - 30 Manual, Chapter 12
Check muffler and exhaust pipe for restrictions	FOS - 30 Manual, Chapter 12

Engine Tune-up—Continued

Operation	Specification	Section-Group Reference
Crankcase Ventilating System Check system for restrictions	FOS - 30 Manual, Chapter 12
Cooling System		
Clean grill screen, radiator core, and oil cooler core	20-30
Clean and flush system; check thermostat	20-30
Check pressure cap	6.25 to 7.50 psi release pressure . . .	20-30
Cylinder Head and Valves		
Torque cylinder head cap screws	180 ft-lbs. in sequence	20-10
Set valve clearance	Intake: 0.018-in. Exhaust: 0.028-in.	20-10
Diesel Fuel System		
Check fuel tank for water	30-15
Check fuel pump pressure	Approx. 20 psi	30-15
Change filter	30-15
Injection Pump:		
Service and check timing	27° BTDC	30-15
Adjust throttle linkage	2300 rpm fast idle speed (hand throttle and foot throttle)	30-20
	800 rpm slow idle speed	30-20
Lubrication system		
Check engine oil pressure	40 - 50 psi (2100 rpm)	20-25
Charging System		
Check battery specific gravity . . .	1.240 - 1.260	40-10
Check battery water consump- tion and electrolyte level	40-10
Clean battery, cables, and box	40-10
Check alternator belt tension . . .	25 lbs. at 1-in. belt deflection	40-10
Check alternator output	50 amps (2000 engine rpm). On air conditioned tractors, 65 amps (2000 engine rpm)	40-10
Check alternator regulated voltage	14.1 - 14.7 volts (operating)	40-10

Engine Tune-up—Continued

Operation	Specification	Section-Group Reference
Starting System		
Check start-safety switch operation	40-15
Check battery voltage when starting	Min. 9 volts (cranking)	40-15
Check starter current draw	Approx. 525 amps	40-15
Check operation of alternator and oil pressure indicator lights	40-25

Final Engine Test

Operation	Specification	Section-Group Reference
Dynamometer Test (at 2100 engine rpm)	Compare with previous recorded-output; record for future use	FOS - 30 Manual - ENGINES, Chapter 12

Tractor Tune-up

Operation	Specification	Section-Group Reference
Adjust transmission clutch free travel	1-11/16-in. (engine at fast idle)	50-5
Transmission		
Check shifting	50-10 & 15
Check for proper operation without excessive noise	50-15
Power Take-Off		
Check for proper operation without excessive noise	50-30
Check brake pedal travel and even position	3-inch maximum travel with brakes bled and with accumulator working properly	70-25
Check tire inflation	See operator's manual
Transmission pump	9 gpm at 1900 rpm (in "Lo" or with 8-speed transmission)	70-5
Main hydraulic pump	Standby - 2200 - 2300 psi Capacity - 21 gpm (2000 psi and 1800 rpm)	70-5
Pressure control valve	1650 - 1700 psi at 800 rpm (approximately 5 gpm flow)	70-5
Selective control valve	2 to 20 gpm at 1200 psi and 1900 rpm	70-5

Tractor Tune-up—Continued

Operation	Specification	Section-Group Reference
Rockshaft:		
Lift cycle time (75 degrees rotation)	2.4 - 2.7 seconds at 1900 rpm	70-5
Maximum oil flow	12.5 gpm at 2000 psi and 1900 rpm	70-5
Lever position (depth control) ...	Complete raise with lever rear edge 1/32- to 1/16-inch from rear of slot	70-30
Lever position (load control)	Begins to raise when rear edge of lever is at "O" on quadrant	70-30
Reverse signal lockout	70-30

Hydraulic system pressures, flow rates, or cycle times are for conditions specified in Section 70 (tractor and transmission-hydraulic oil at operating temperature, proper test equipment, correct test sequence, etc.).

Group 20 LUBRICATION

GENERAL INFORMATION

Carefully written and illustrated instructions are included in the tractor operator's manual. Remind your customer to follow the recommendations in these instructions.

For your convenience when servicing the tractor, the following chart showing capacities and type of lubricant for the various components has been included. Additional lubrication information is on page 20-2.

Component	Capacity	Type of Lubricant	Interval of Service
Engine Crankcase	26 U.S. quarts (Includes filter)	See "Engine Lubricating Oils" on page 20-2	10 Hours - Check level 100 Hours - Change oil 200 Hours - Replace filter
Transmission and Hydraulic system	22 U.S. gallons (dry system) 19 U.S. gallons at service intervals	John Deere Type 303 Special-Purpose Oil	200 Hours - Check level 600 Hours - Replace filter 1200 Hours - Change oil
Front differential	7 U.S. gallons	John Deere Type 303 Special-Purpose Oil	1200 Hours - Change oil
Grease Fittings	John Deere Multi-purpose Lubricant	See Operator's Manual

LUBRICANTS

Engine Lubricating Oils



We recommend John Deere Torq-Gard or Torq-Gard Supreme Engine Oil for use in the engine crankcase. These oils are compounded specifically for use in John Deere engines and provide superior lubrication under all conditions. NEVER PUT ADDITIVES IN THE CRANKCASE. Torq-Gard oils are formulated to provide all the protection this engine needs. Additives could reduce this protection rather than help it.

If Torq-Gard or Torq-Gard Supreme is not used, use an engine oil that conforms to one of the following specifications:

SINGLE VISCOSITY OILS

API Service CD/SD
MIL-L-2104C
Series 3*

MULTI-VISCOSITY OILS

API Service CC/SE, CC/SD, or SD
MIL-L-46152

* As further assurance of quality, the oil should also be identified as suitable for API service designation SD.

Depending on the expected prevailing temperature for the fill period, use oil of viscosity as shown in the following chart.

Air Temperature	John Deere Torq-Gard Oil	Other Oils	
		Single Viscosity Oil	Multi-Viscosity Oil
Above 32°F.	SAE 30	SAE 30	Not recommended
-10°F. to 32°F.* *	SAE 10W-20	SAE 10W	SAE 10W-30
Below -10°F.	SAE 5W-20	SAE 5W	SAE 5W-20

* * SAE 5W-20 oil may be used where required to insure optimum lubrication at starting, particularly for an engine subjected to -10°F. or lower for several hours.

Some increase in oil consumption may be expected when SAE 5W-20 or SAE 5W oils are used. Check oil level more frequently.

Transmission Hydraulic Oils

Use only John Deere Type 303 Special-Purpose Oil or its equivalent in the transmission-hydraulic system. Other types of oil will not give satisfactory service, and may result in eventual damage. This special oil may be used in all weather conditions.

Greases

John Deere Multi-Purpose Lubricant or an equivalent SAE Multipurpose-Type grease is recommended for grease fittings. Application of grease as instructed in the lubrication section of the operator's manual will provide proper lubrication and will keep contamination out of bearings.

Storing Lubricants

A tractor can operate at top efficiency only if clean lubricants are used. Use clean containers to handle all lubricants. Store them in an area protected from dust, moisture, and other contamination.

Group 25 SEPARATION

CAUTION: Before separating tractor, be sure that the brake accumulator is discharged. The accumulator can be discharged by opening the right-hand brake bleed screw, and holding the brake pedal down for a few minutes. Do not work around hinge with the engine running.

REMOVING ROLL-GARD CAB

The Roll-Gard cab is bolted to special brackets that are fastened to the front hinge and side frames.

To facilitate the removal of the Roll-Gard cab, turn the tractor to either the extreme left or right turn position, loosen the Roll-Gard attaching bolts, and then turn to the other extreme position, and loosen the bolts (fig. 4).

CAUTION: To prevent possible injury, do not work around the hinge with the engine running. Always be sure that the engine is stopped, and that no one is in cab before proceeding with the removal.

Drain the cooling system. Remove the muffler, vertical air stack, side grille screens, cowi, cab center panel, and hood.

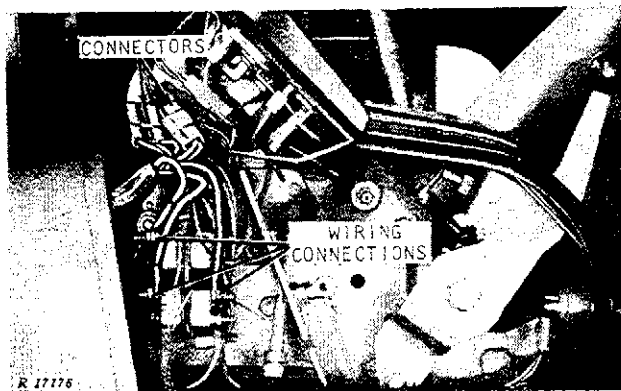

Fig. 1-Cab Wiring Connections

1. Disconnect cab wiring from connectors and circuit breakers (Fig. 1). Remove wiring harness from clamps and lay wiring inside cab. Disconnect wiring from dimmer switch.

2. Disconnect heater pressure and return hoses (Fig. 2).

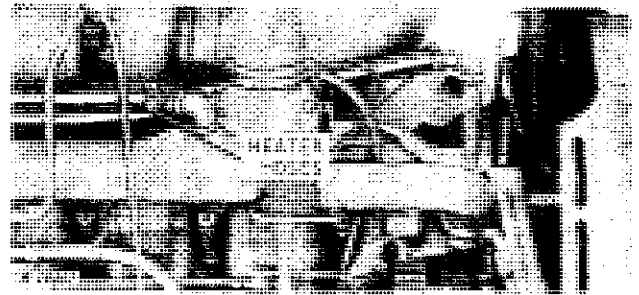

Fig. 2-Heater Hoses

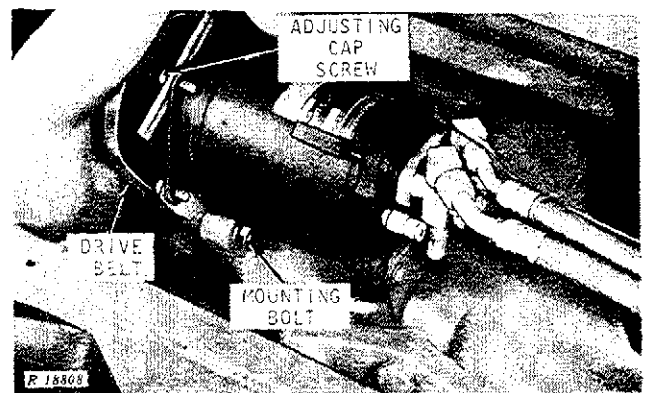

Fig. 3-Compressor Mounting

3. Loosen the compressor drive belt and remove the compressor mounting bolt (Fig. 3). Remove compressor (with refrigerant hoses connected to compressor), and place unit inside cab or fasten to cab. Do not disconnect the refrigerant hoses unless absolutely necessary.

CAUTION: Whenever the refrigerant hoses are to be disconnected, first discharge the compressor or the complete system as explained in SM-2089 (Tractor Air Conditioning and Heating Systems) under **DISCHARGING THE SYSTEM**. Follow all safety precautions listed in the manual to avoid personal injury.

Disconnect hydraulic hoses from breakaway couplers, rockshaft, and selective control valve manifold (pressure and return) on tractors with rockshaft. Remove the cab floor mat, and the necessary cab panels to allow cab to clear the control support housing and seat.

Fasten cab lifting bracket (Group 30, Fig. 2) to the lifting straps on cab roof and attach to an overhead hoist.

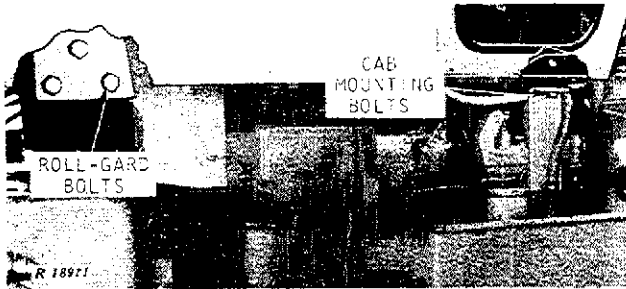

Fig. 4-Roll-Gard and Cab Mounting Bolts

Remove Roll-Gard and cab mounting bolts (Fig. 4). Be sure that all hoses and wiring are disconnected from tractor. Lift off cab.

INSTALLING ROLL-GARD CAB

Reverse the removal steps. Torque Roll-Gard bolts to 670 ft-lbs.

The centerline of cab should line up with the centerline of tractor. The foam rubber seal on center cowl panel of cab should be equally compressed around the contour of hood. Shift cab as required to align correctly.

After the cab panels and extensions are in place, seal all holes and openings with tape, foam material, or sealant before installing floor mat. Careful sealing of all openings must be done for the pressurizer to be effective in keeping out dust and dirt.

Install floor mat. Install air conditioning compressor (if equipped), and adjust the drive belt to 1/4-inch deflection with a 15-pound force.

Position hoses and wiring carefully to prevent rubbing or chafing and premature failure.

SEPARATING ENGINE FROM CLUTCH HOUSING

Use the following method of separation to permit working on clutch or related parts. When removing the engine, use the method explained under "Separating Engine From Tractor Front End," and "Removing Engine."

Discharge the accumulator. Remove muffler, air stack, grille screens, cowl, cab center panel, and hood. Disconnect battery ground cable, and drain cooling system.

Disconnect hydraulic pump inlet pipe at filter relief valve to drain oil from cooler and reservoir.

Disconnect the front differential drive shaft at the universal joint adjacent to the differential housing.

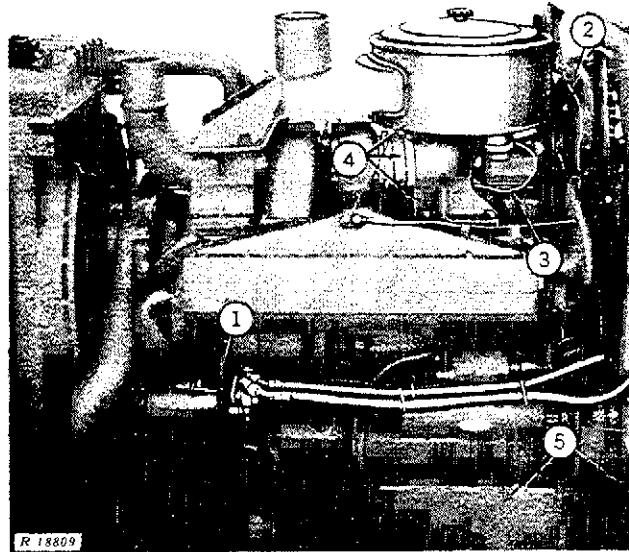

Fig. 5-Left-Hand Removal Steps

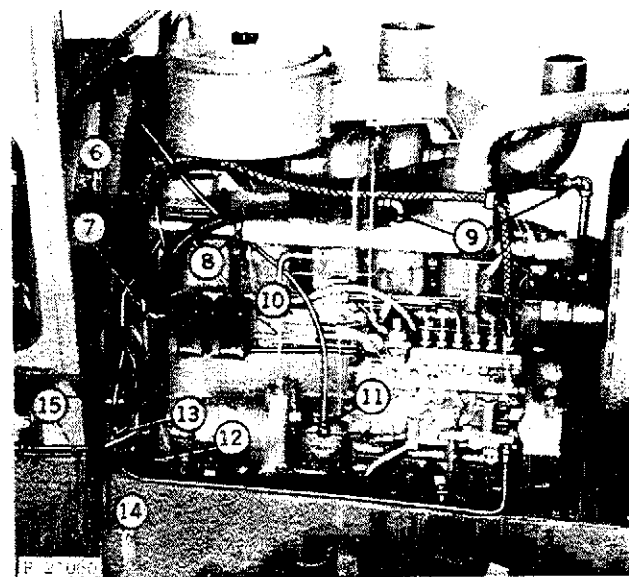

Fig. 6-Right-Hand Removal Steps

1. On tractors with air conditioning, remove the compressor (Figs. 3 and 5) with hoses attached, and place inside the cab.

2. Disconnect ether starting aid pipe at connector, and remove clamp from pipe on firewall.

3. Disconnect ground wire from air cleaner-to-elbow bolt, and disconnect wiring from restriction indicator switch.

4. Loosen air cleaner elbow-to-turbocharger hose clamps, and remove cap screws fastening the air cleaner elbow to engine cylinder head. Remove air cleaner, elbow, and hose.
5. Disconnect front headlamp wiring at connector below starter, and disconnect hydraulic pump inlet pipe at connector next to clutch housing.
6. Disconnect wiring harness from connectors and clamp (Fig. 6).
7. Disconnect and remove fuel return pipe from engine and fuel tank, (Fig. 6 and 7). Disconnect and remove crankcase vent hose and pipe.
8. Disconnect temperature gauge sensing bulb from water manifold.
9. Loosen hose clamps on both heater hoses (if equipped), remove clamp from hoses on firewall, and place hoses out of way.
10. Remove control support covers. Disconnect and remove speed control rod and fuel shut-off cable.
11. Disconnect tachometer cable.
12. Disconnect cooler return pipe at hose connection between side frame and clutch housing.
13. Disconnect fuel pump inlet pipe.
14. Disconnect the hydraulic pump discharge hose at manifold.
15. Remove cap screws from manifold on top of side frame.

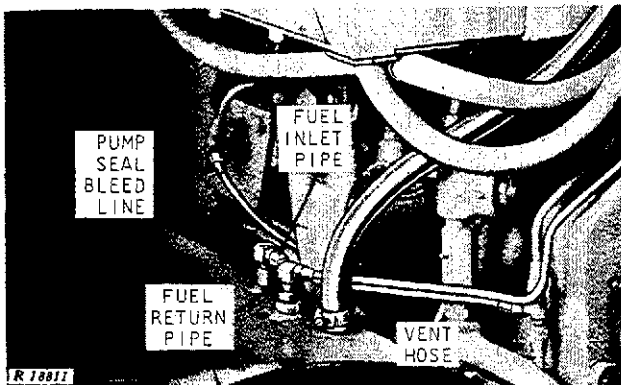

Fig. 7-Bleed line and Fuel Tank Connections

Disconnect the hydraulic pump seal bleed line (Fig. 7).

Drain fuel from both fuel tanks (capacity of each tank is 78 gallons). Be sure to drain the fuel down to a level below the crossover hoses. Place a floor jack under tank support. Disconnect vent hose and fuel inlet pipe from each tank (Fig. 7). Disconnect the fuel gauge sending unit wire from the left-hand tank, and disconnect the crossover hoses from each fuel tank (Fig. 8).

Remove tank mounting bolts and cap screws. Place tank in a stable position, and cover the tank openings to prevent contamination by dirt, water, or other foreign material.

Install JDG-1-9 engine lifting brackets. Attach JDG-1 engine lift sling to engine lifting brackets and to an overhead hoist.

Install a wedge or block between the front axle housing and the engine side frame. A wedge should be used on both sides to prevent rocking of front end.

Place a jack under the front hinge. Use a substantial metal stand to support the rear portion of tractor. **IMPORTANT: Do not place jack at front end of steering cylinder frame.**

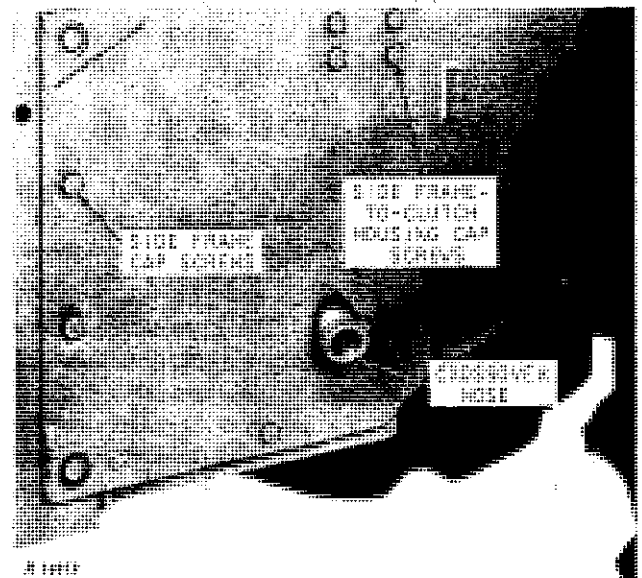

Fig. 8-Disconnecting Side Frames From Tractor

Remove the side frame cap screws, and the side frame-to-clutch housing cap screws (Fig. 8).

Remove the engine-to-clutch housing cap screws.

Roll engine and tractor front end away from clutch housing (Fig. 9).

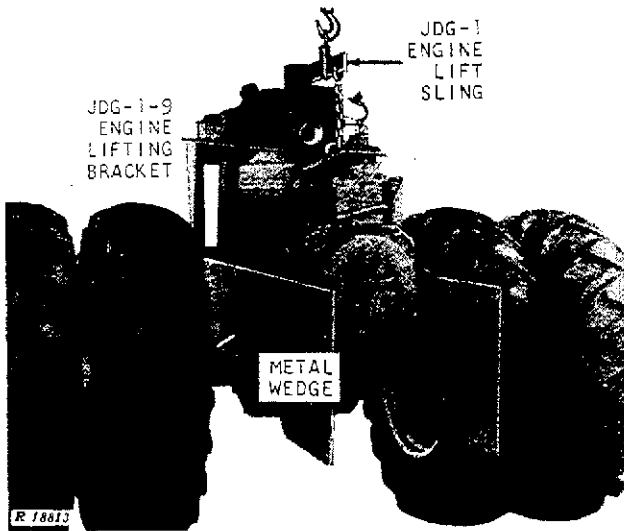

Fig. 9-Engine Separated From Clutch Housing

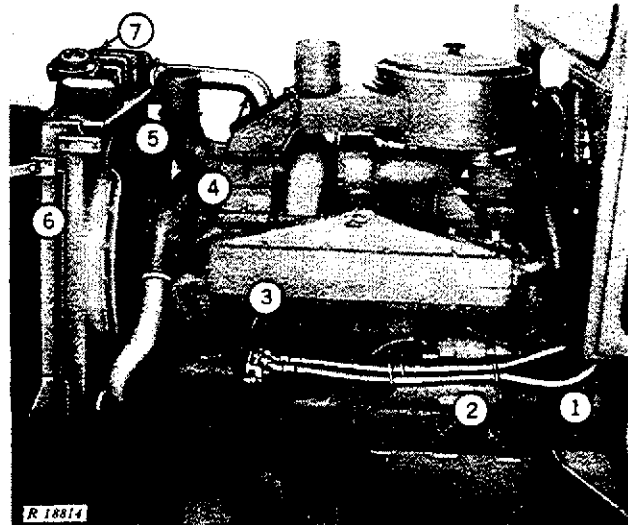

Fig. 10-Left-Hand Side Removal Steps

ASSEMBLY

Apply a light coating of Permatex to engine and clutch housing mating surfaces, and roll front and rear units together. Never use excessive force.

Reverse the removal steps. Tighten cap screws to specification (page 30-1).

Install hood and cowl, muffler, air stack, and fuel tanks. Connect battery ground cable, and fill the cooling system. Start engine and check tractor operation.

SEPARATING ENGINE FROM TRACTOR FRONT END

Use the following method of separation when desiring to remove the tractor front end from the engine for repair.

Discharge the accumulator. Disconnect the battery ground cable and drain cooling system. Remove muffler, air stack, grille screens, cowl, cab center panel, and hood. Disconnect the battery cables and remove the rubber grommets from cables. Remove the battery cables from battery compartment through the holes where rubber grommets were positioned. Drain the cooling system.

Disconnect hydraulic pump inlet pipe at filter relief valve to drain oil from cooler and reservoir.

Disconnect the front differential drive shaft at the universal joint adjacent to the differential housing.

1. Remove fuel tanks (Fig. 10), following instructions given at the top of the right-hand column of previous page.
2. Disconnect front headlamp wiring at connector below starter, and remove headlamp wiring bands from hydraulic pump inlet pipe.
3. Remove air conditioning compressor (Fig. 3) with hoses attached, and place inside cab, if engine is to be removed.
4. Remove upper and lower radiator hoses.
5. Remove the screws fastening fan shroud to radiator.
6. Disconnect radiator support straps from radiator.
7. Remove radiator and fan shroud.

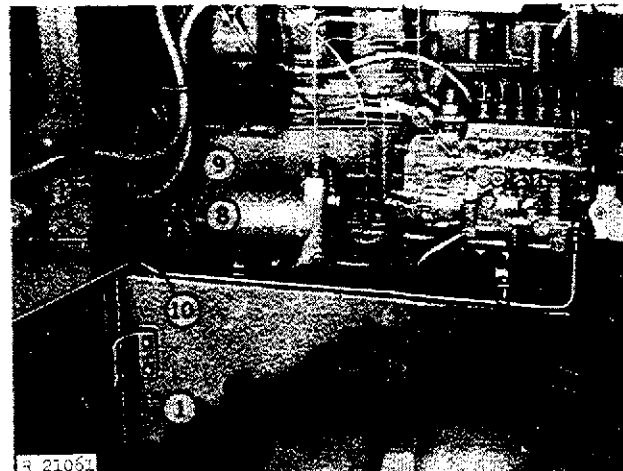

Fig. 11-Right-Hand Side Removal Steps

8. Disconnect cooler return pipe at hose connection between side frame and clutch housing (Fig. 11).

9. Disconnect fuel pipe at connector and at pump.

10. Disconnect hydraulic pump discharge hose at manifold and at pump. Remove discharge hose-to-side frame clamps, and remove discharge hose and fuel pipe.

11. Disconnect manifold from top of side frame by removing the two cap screws.

Disconnect the hydraulic pump seal bleed line (Fig. 7), and remove the spring clips which fasten the bleed line to the top flange of side frame. Remove bleed line.

Disconnect hydraulic oil cooler inlet hose at pump.

Install a wedge or block between the front axle housing and the engine side frame. A wedge should be used on both sides to prevent rocking of front end.

Place a jack under the front hinge. Use a substantial metal stand to support the rear portion of tractor. **IMPORTANT: Do not place jack at front end of steering cylinder frame.**

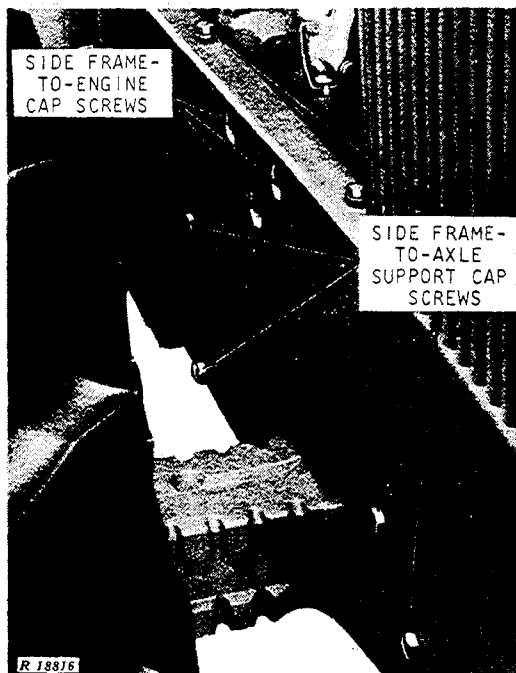

Fig. 12-Engine and Axle Support Cap Screws

Loosen the side frame-to-front axle support cap screws (Fig. 12) to prevent excessive binding of side frames during removal. Remove the cap screws fastening the side frames to engine mounting pads.

Place a chain around each side frame at the front, as shown in Fig. 13, and attach to an overhead hoist.

Remove the side frame cap screws, and the side frame-to-clutch housing cap screws (Fig. 8).

Roll the tractor front end away from engine (Fig. 13). Place a support stand under side frames in front of differential.

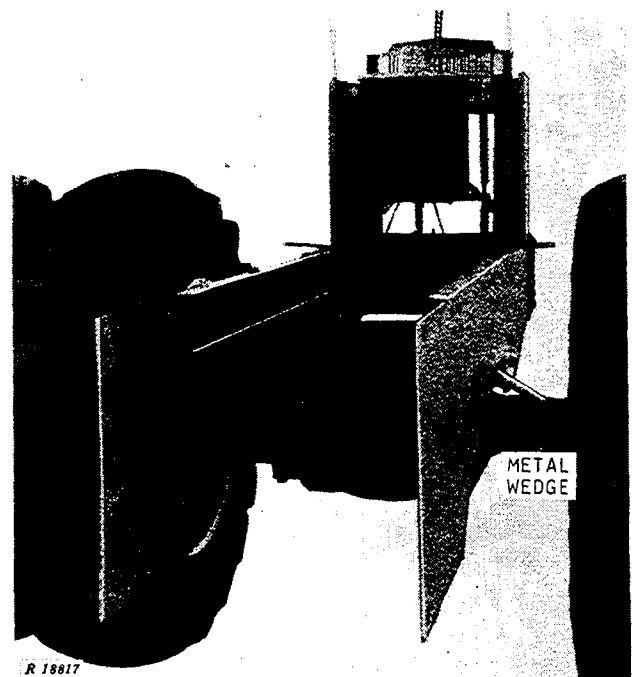

Fig. 13-Tractor Front End After Separation

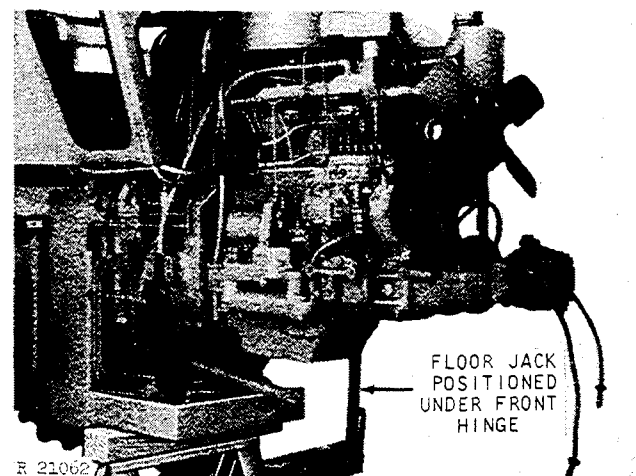

Fig. 14-Engine After Separation

ASSEMBLY

Reverse the numbered removal procedures. Tighten cap screws to specifications.

Install hood, cowl, cab center panel, grille screens, muffler, and air stack. Connect battery cables, and fill the cooling system.

Start engine and check tractor for leaks and for proper operation.

REMOVING ENGINE

Follow instructions given on page 25-4, under "Separating Engine From Tractor Front End." After the tractor front end has been removed from the remaining part of the tractor, use the following procedure to remove the engine.

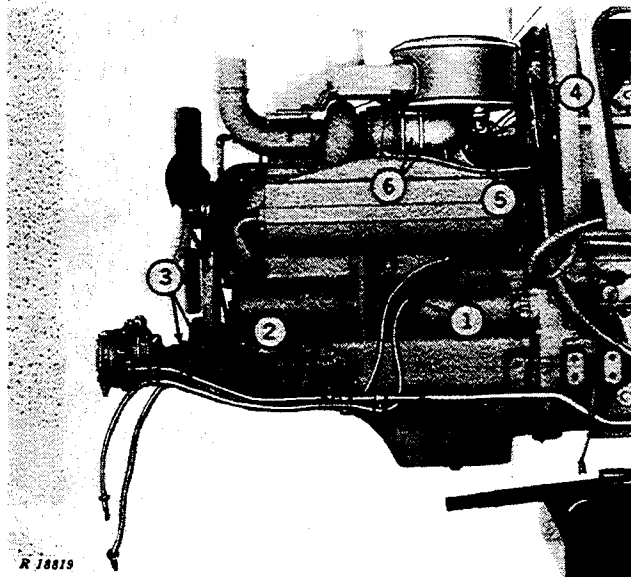

Fig. 15-Left-Hand Side of Engine

1. Disconnect battery cables from starter (Fig. 15).
2. Remove cap screw from hydraulic pump inlet pipe clamp, and disconnect pipe at both ends. Remove pipe with starter cables attached.
3. Disconnect and remove hydraulic pump coupling. Loosen and remove the pump mounting bracket-to-engine cap screws. Remove hydraulic pump with bracket attached.
4. Disconnect ether starting aid pipe.

5. Disconnect ground wire from air cleaner mounting bolt and disconnect wiring from restriction indicator switch.

6. Loosen hose clamps and remove air cleaner elbow-to-cylinder head cap screws. Remove air cleaner, elbow, and hose.

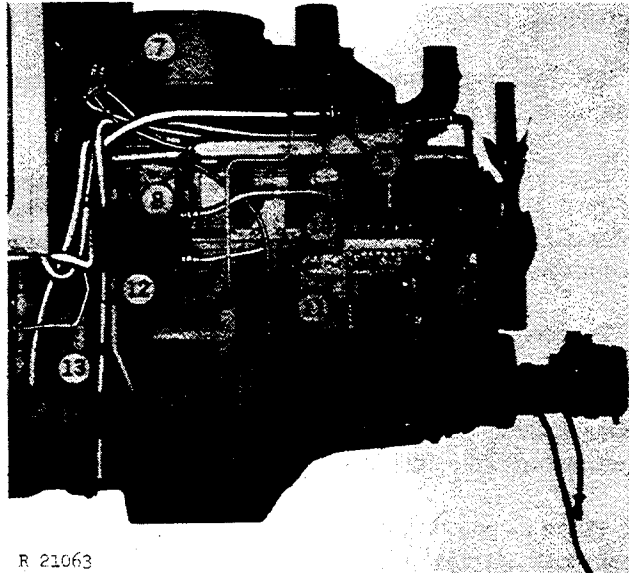

Fig. 16-Right-Hand Side of Engine

7. Disconnect wiring harness from connectors and clamp (Fig. 16).
 8. Disconnect temperature gauge sensing bulb from water manifold.
 9. Loosen hose clamps on both heater hoses (if equipped), remove clamp from hoses on firewall, and place hoses out of way.
 10. Remove control support covers, disconnect the speed control rod, and remove rod. Disconnect fuel shut-off cable.
 11. Disconnect tachometer cable.
 12. Disconnect and remove crankcase vent hose and pipe.
 13. Remove fuel tank vent hose and fuel return pipe, if not already removed.
- Install JDG-1-9 engine lifting brackets. Attach JDG-1 engine lift sling to lift brackets and to overhead hoist.

Remove the cap screws fastening engine to clutch housing, and remove engine (Fig. 17).

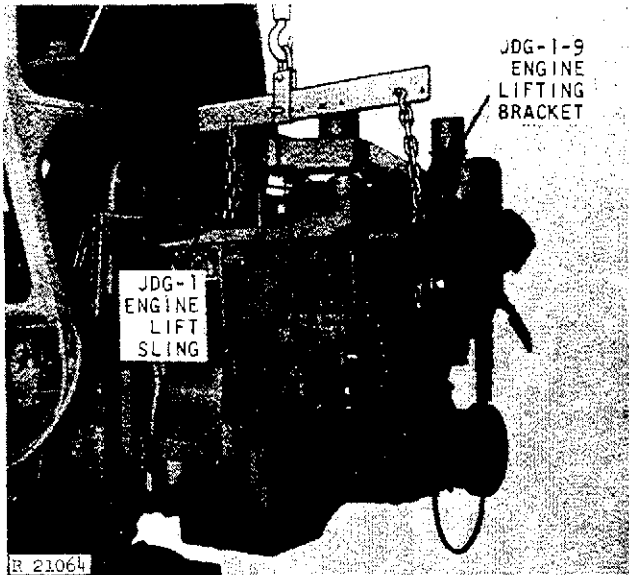

Fig. 17-Removing Engine

ASSEMBLY

Apply a light coating of Permatex to clutch housing and engine mating surfaces, and join together. Never use excessive force.

Reverse the removal steps. Tighten cap screws and bolts to specification.

For information on joining tractor front end to engine and hinge, refer to the preceding page.

REMOVING FRONT AXLE ASSEMBLY WITH AXLE SUPPORT

The front axle assembly may be removed with or without the axle support (Fig. 18). Remove the axle assembly with axle support when work is to be done on the engine without removing side frames. Remove the axle assembly without the axle support when repair is to be made on the axle assembly only.

CAUTION: When removing or installing front axle assembly with axle support, the differential and axle support will turn upside down if assembly is allowed to get out of balance. Keep differential and axle support balanced or supported to prevent possible injury.

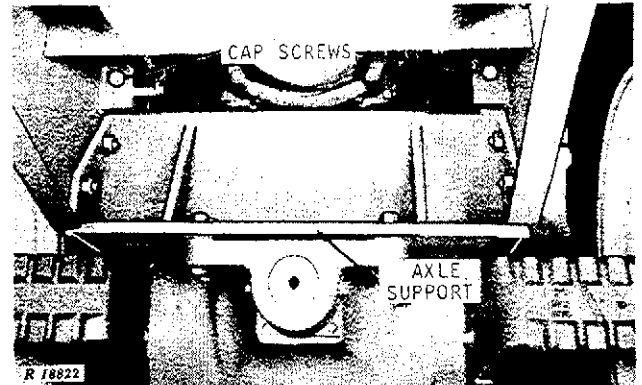

Fig. 18-Front Axle Support Upper Cap Screws

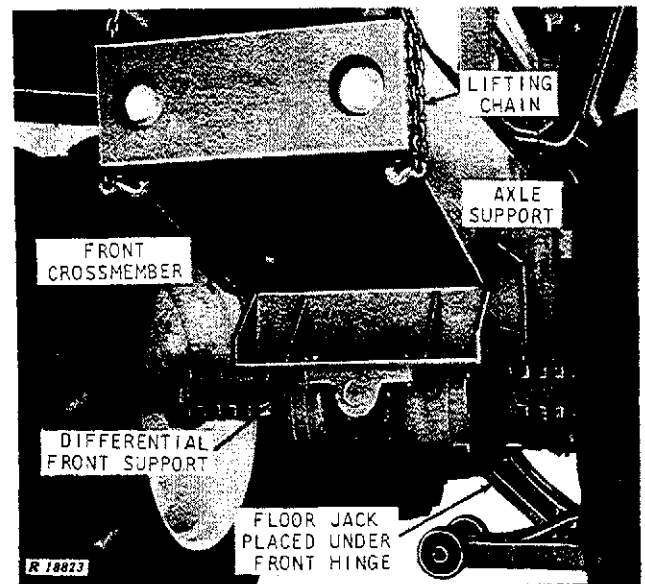

Fig. 19-Removing Front Axle Assembly With Axle Support

Refer to Figs. 18 and 19 while performing the following steps:

1. Disconnect the front differential drive shaft at the universal joint next to the differential housing.
2. Remove the two upper cap screws (Fig. 18).
3. Wrap a chain around each side frame and support with a suitable overhead hoist. Do not lift from front crossmember.
4. Place a jack under the front hinge to help lift and support the tractor front end.
5. Remove the six cap screws on each side frame fastening the front axle support to the engine side frame (Fig. 12).
6. Raise the tractor front end and roll axle assembly out from under tractor (Fig. 19).

ASSEMBLY

Reverse the removal steps. Tighten the axle support-to-side frame cap screws to 300 ft-lbs torque. Be sure differential drive shaft universal joints are correctly "timed." Tighten universal joint cap screws to 70 ft-lbs torque.

REMOVING FRONT AXLE ASSEMBLY WITHOUT AXLE SUPPORT

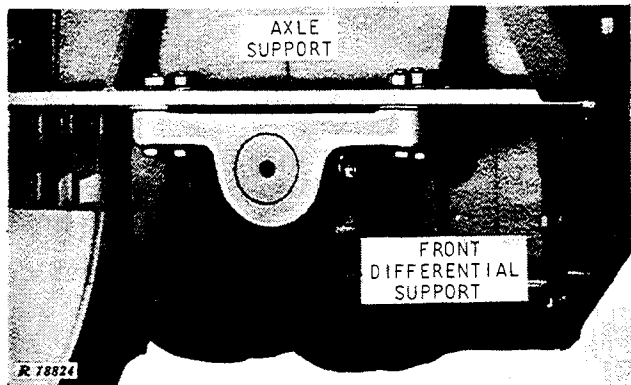

Fig. 20-Differential Front Support

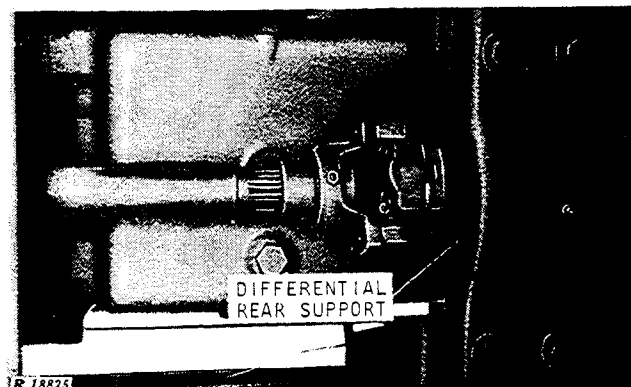

Fig. 21-Differential Rear Support

Remove the bolts fastening the differential front support to the axle support (Fig. 20).

Wrap a chain around each side frame and support with a suitable overhead hoist. Do not lift from the front crossmember.

Place a floor jack under the front hinge to help lift and support the tractor front end.

Remove the eight cap screws fastening the differential rear support to the axle support (Fig. 21).

Disconnect the front differential drive shaft at the universal joint next to the differential housing.

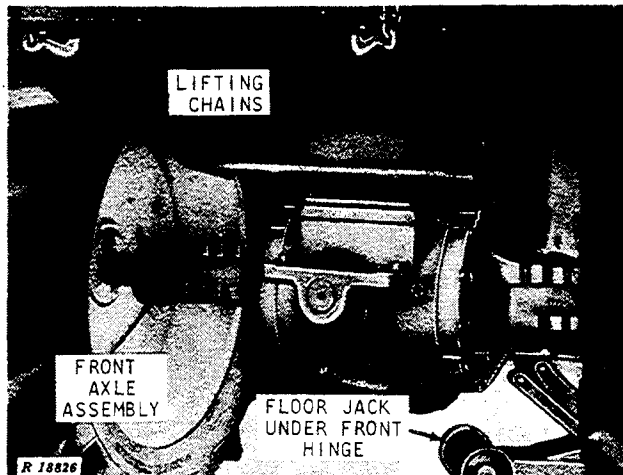

Fig. 22-Removing Front Axle Assembly Without Axle Support

Raise the tractor front end as shown in Fig. 22, and roll front axle assembly out from under tractor.

ASSEMBLY

Roll front axle assembly back under tractor, and reverse the removal procedures. Tighten the differential front support-to-axle support bolts to 170 ft-lbs torque. Tighten the differential rear support-to-axle support cap screws to 300 ft-lbs for 3/4-inch screws, and to 445 ft-lbs for 7/8-inch screws.

Be sure differential drive shaft universal joints are "in time". Tighten universal joint cap screws to 70 ft-lbs torque.

SEPARATING TRANSMISSION AND DIFFERENTIAL FROM TORQUE DIVIDER

Install hinge lock pin.

Discharge accumulator (open right-hand brake bleed screw, and hold brake pedal down for a few minutes).

Drain the transmission. Remove the drawbar and drawbar support. Install JDG-2M rear support stand under transmission case (Fig. 25).

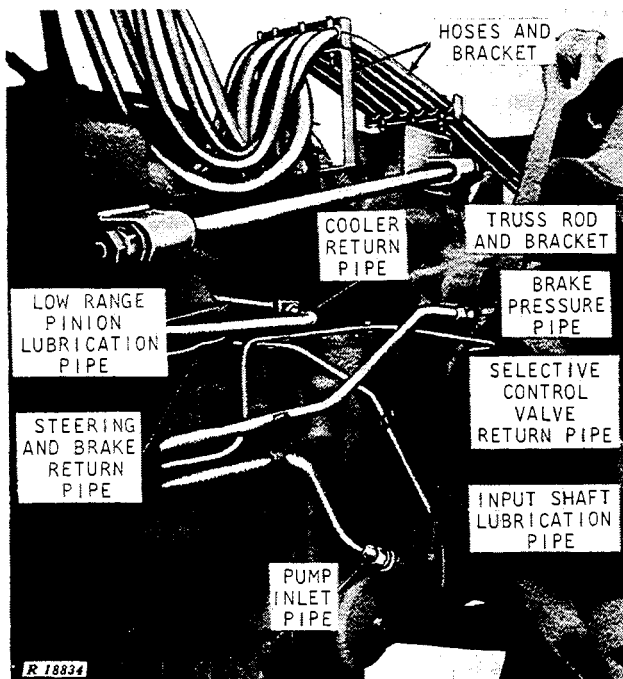

Fig. 23-Left-Hand Side of Transmission Case

Disconnect remote cylinder outlets from top of differential housing, leaving hoses attached. Remove hose guide. On tractors with a rockshaft, disconnect pressure hoses from remote cylinder outlets and rockshaft. After capping the hoses, remove the hoses and bracket (Fig. 23), and place out of way.

Disconnect the hydraulic cooler return pipe steering and return pipe, brake pressure pipe, hydraulic pump inlet pipe, selective control valve return pipe, and lubrication pipes for torque divider. Remove rockshaft-to-rear hinge truss rods with bracket.

NOTE: When the torque divider input shaft lubrication pipe has been disconnected from the oil filter relief valve housing, the transmission pump check valve and spring may or may not drop out. Be sure that these parts are in place before connecting pipe.

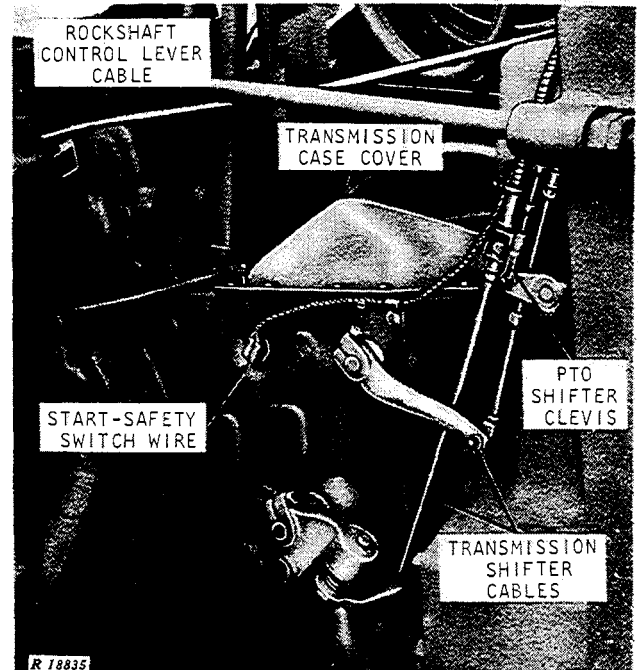

Fig. 24-Right-Hand Side of Transmission Case

Disconnect the start-safety switch wire and transmission shifter cables from arms (Fig. 24). On tractors with a rockshaft, disconnect the rockshaft control lever cable.

Remove the transmission case cover and remove the two cap screws inside transmission case which fasten case to torque divider.

Disconnect the front differential drive shaft at universal joint next to front hinge.

Place a substantial jack under front hinge, and place an adequate support stand under rear hinge.

Remove the three long cap screws (Fig. 26) which fasten the transmission case and torque divider to the rear hinge. Then remove the cap screws fastening the transmission case to the torque divider housing. Roll tractor rear end away from torque divider housing (Figs. 25 and 26).

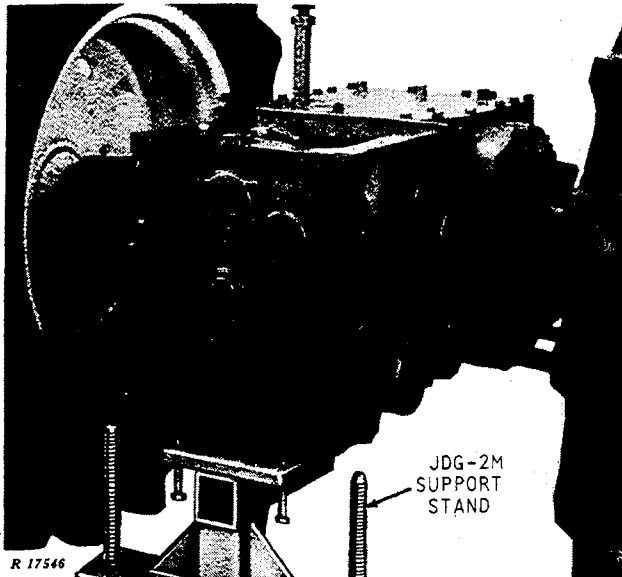

Fig. 25-Rear Section of Tractor After Separation (Tractor without Rockshaft)

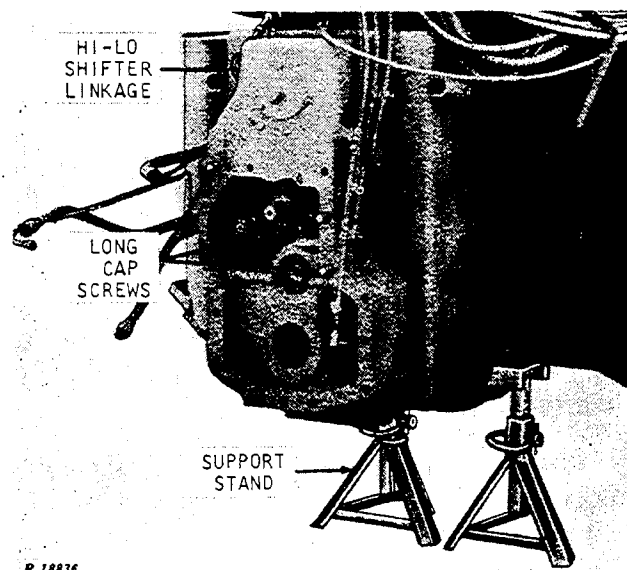

Fig. 26-Front Section of Tractor After Separation

ASSEMBLY

Reverse the removal steps. Be sure that transmission pump check valve and spring are installed in oil filter relief valve housing before installing torque divider input shaft lubrication pipe.

Be sure differential drive shaft universal joints are "in time". Tighten universal joint cap screws to 70 lbs torque.

IMPORTANT: When installing drive shafts, arrows (Fig. 27) must point together on all drive shafts. Each drive shaft assembly is a balanced unit. Do not permit shaft assemblies to become intermixed.



Fig. 27-Drive Shaft Arrows

Tighten cap screws and bolts to specification. Remove hinge lock pin, and JDG-2M support stand. Install drawbar support and drawbar.

Fill transmission with oil to correct level. Check tractor for proper operation.

SEPARATING TORQUE DIVIDER AND TRACTOR REAR END FROM HINGE

Install hinge lock pin.

Discharge accumulator (open right-hand brake bleed screw, and hold brake pedal down for a few minutes).

Drain the transmission. Remove the drawbar and drawbar support. Install JDG-2M rear support stand under transmission case (Fig. 25).

Disconnect the oil cooler return pipe, steering and brake return pipe, hydraulic pump inlet pipe, selective control valve return pipe, and the brake pressure pipe from left-hand side of tractor (Fig. 23). Install cap-plugs to prevent entry of foreign material into hydraulic system.

Disconnect transmission shifter cables, rockshaft control lever cable (if equipped), PTO shifter clevis, and start-safety switch wire (Fig. 24). Remove cap screws securing shifter cable clamps to the torque

divider case. Disconnect the Hi-Lo shifter linkage (Fig. 26). Disconnect both drive shafts at the universal joints inside hinge next to the torque divider case. On tractors with rockshaft, disconnect hoses from remote cylinder outlets, and rockshaft pressure hose. Disconnect rockshaft-to-rear hinge truss rods.

Remove cap screws fastening torque divider and tractor rear end to hinge. Roll unit back away from hinge (Figs. 28 and 29).

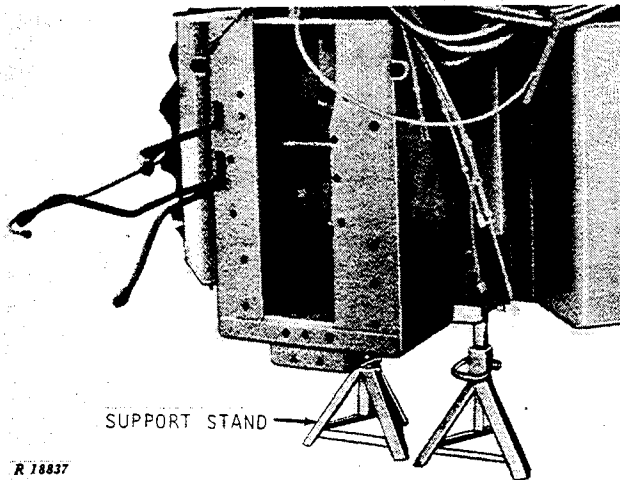

R 18837

Fig. 28-Front Section of Tractor After Separation

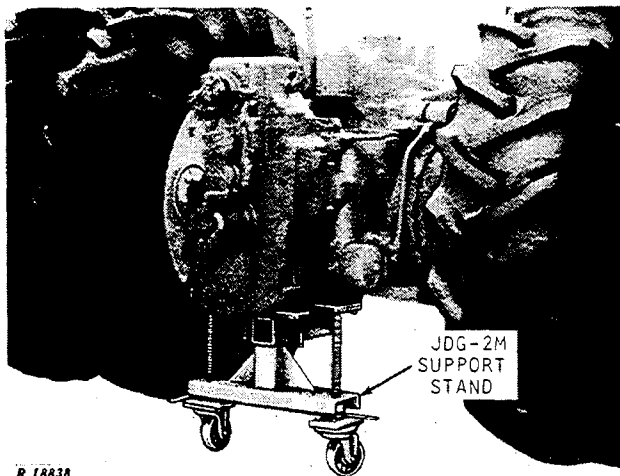

R 18838

Fig. 29-Rear Section of Tractor After Separation

ASSEMBLY

Reverse the removal steps. Remove caplugs from pipes and fittings.

Be sure differential drive shaft universal joints are "in time". Tighten universal joint cap screws to 90 ft-lbs torque.

IMPORTANT: When installing drive shafts, arrows (Fig. 27) must point together on all drive shafts. Each drive shaft assembly is a balanced unit. Do not permit shaft assemblies to become intermixed.

Tighten cap screws and bolts to specifications. Remove hinge lock pin, and JDG-2M support stand. Install drawbar support and drawbar.

Fill transmission with oil to correct level. Check tractor for proper operation.

SEPARATING CLUTCH HOUSING FROM FRONT HINGE

To facilitate removal of the clutch housing cap screws and pipes inside the front hinge, turn the tractor to the extreme right. Shut off engine.

Discharge the brake accumulator (open right-hand brake bleed screw and hold brake pedal down for a few minutes).

Separate the engine and tractor front end from the clutch housing. See page 25-2.

Remove Roll-Gard cab. See page 25-1.

Disconnect the pipes from brake reservoir and pressure control valve. Disconnect the transmission and PTO shift-cables. Disconnect drive shafts at the front hinge.

Disconnect pipes, hoses, and wiring from front hinge that are connected to the control support.

Disconnect the control support from clutch housing. Install control support lift bracket (Group 30, Fig. 1), and attach to an overhead hoist. Remove control support.

Remove the cap screws that fasten the clutch housing to the front hinge, and remove clutch housing.

ASSEMBLY

Reverse the removal procedures. Tighten the clutch housing-to-front hinge cap screws to 300 ft-lbs torque.

After the tractor has been completely assembled, check for leaks and test operation.

REMOVING FINAL DRIVE ASSEMBLY

Drain the transmission. Raise tractor enough to remove rear wheel.

Wrap a chain around the axle housing, and attach to an overhead hoist. Remove the cap screws fastening the rear axle housing to the transmission case. Hold backing plate to transmission case when removing the housing.

Remove sun pinion, brake backing plate, and brake disk.

To remove the front final drive assembly, remove the front axle assembly without axle support, described on page 25-8. Then remove the final drive as described on this page.

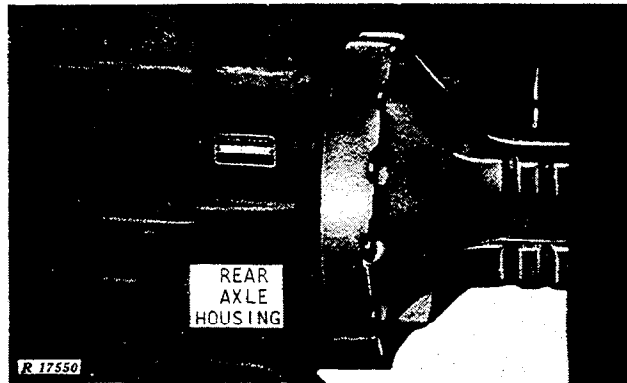

Fig. 30-Rear Axle Housing

INSTALLING FINAL DRIVE

Reverse the removal procedure.

IMPORTANT: To prevent serious damage when installing the final drive housing, be sure that the sun pinion does not work outward far enough to allow the brake disk to drop inside the sun pinion teeth.

Tighten axle housing cap screws to 170 ft-lbs torque.

Group 30

SPECIFICATIONS AND SPECIAL TOOLS

SPECIFICATIONS

Item	Specification
Air conditioning compressor	
belt deflection (at 15 lbs pull)	0.25 in.
Fan belt deflection (at 25 lbs pull)	1 in.

Item	Torque (Ft-Lbs)
Hydraulic pump drive coupling	30
Hydraulic pump support-to-engine	85
Side frames-to-engine	300
Side frames-to-hinge	300
Side frames-to-axle support	
5/8-inch cap screws	170
3/4-inch bolts	300
Clutch housing-to-engine	300
Clutch housing-to-hinge	300
Torque divider and input	
housing-to-hinge (long cap screws)	300
Transmission-to-torque divider	300
Front differential-to-axle support	
5/8-inch (front) bolts	170
3/4-inch (rear) cap screws	300
7/8-inch (rear) cap screws	445
Front axle drive shafts	
Front drive shaft U-joints	70
Rear drive shaft U-joints	90
Input housing drive shaft U-joints	70
Drawbar support-to-transmission case	300
Wheel hub-to-axle	300
Roll-Gard-to-hinge	670
Axle housing-to-transmission case	170
Rockshaft-to-rear hinge truss rods	100

SPECIAL TOOLS

No.	Name	Use
JDG-1-9*	Engine Lift	
	Brackets	Engine removal
JDG-1*	Engine Sling	Engine removal
JDG-2M*	Rear Stand	Tractor separation
	Lift Bracket	Lifting clutch housing assembly
	Lift Bracket	Lifting Roll-Gard Cab

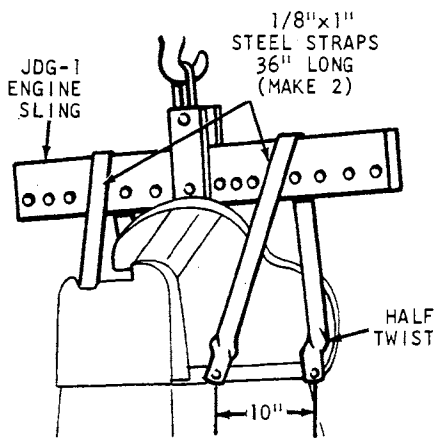

R 14392

Fig. 1-Clutch Housing Assembly Lift Bracket

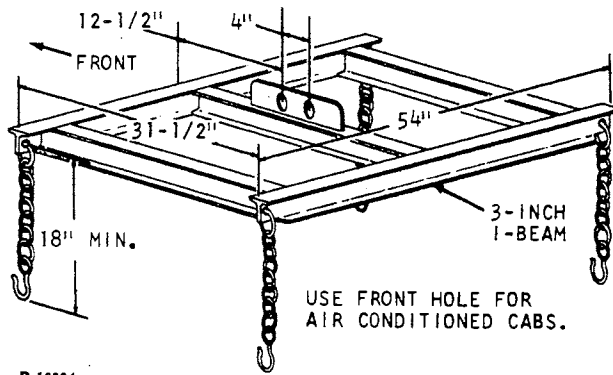

R 18024

Fig. 2-Cab Lift Bracket

* Order from Service Tools, Inc., 1901 Indiana Avenue, Chicago, Illinois 60616.

Section 20 ENGINE

CONTENTS OF THIS SECTION

	Page		Page
GROUP 5 - GENERAL INFORMATION AND DIAGNOSIS		Inspection and Repair	
General Information	5-2	Crankshaft and Flywheel	20-1
Diagnosing Engine Malfunctions	5-2	Main Bearings and Journals	20-2
		Damper Pulley	20-3
		Rear Crankshaft Oil Seal, Housing, and Wear Sleeve	20-3
GROUP 10 - CYLINDER HEAD, VALVES, AND CAMSHAFT		Front Oil Seal and Wear Sleeve	20-3
General Information	10-1	Assembly	20-3
Diagnosing Malfunctions	10-1	Installation	20-5
Cylinder Head and Valves			
Removal and Repair	10-2	GROUP 25 - LUBRICATION SYSTEM	
Assembly and Installation	10-4	General Information	25-1
Valve Clearance Adjustment	10-4	Diagnosing Malfunctions	25-1
Camshaft		Oil Pressure Regulating Housing Repair	25-1
Removal	10-4	Oil Pump Repair	25-2
Repair	10-5	Assembly	25-3
Installation	10-5		
GROUP 15 - CYLINDER BLOCK, LINERS, PISTONS AND RODS		GROUP 30 - COOLING SYSTEM	
General Information	15-1	General Information	30-1
Diagnosing Malfunctions	15-1	Diagnosing Malfunctions	30-1
Removal	15-2	Radiator And Fan	30-1
Repair		Water Pump	30-1
Pistons	15-2	Water Manifold and Thermostats	30-3
Liners	15-3		
Rods	15-4	GROUP 35 - SPECIFICATIONS	
Assembly	15-4	Cylinder Head, Valves, and Camshaft	35-1
Installation	15-5	Cylinder Block, Liners, Pistons and Rods	35-1
		Crankshaft, Main Bearings and Flywheel	35-1
GROUP 20 - CRANKSHAFT, MAIN BEARINGS, AND FLYWHEEL		Lubrication System	35-2
General Information	20-1	Cooling System	35-2
Diagnosing Malfunctions	20-1	Torques for Hardware	35-2
Checking End Play	20-1	Special Tools	35-3
Removal	20-1	Engine Break-In	35-3

Group 5 GENERAL INFORMATION AND DIAGNOSIS

GENERAL INFORMATION

The engine is a turbo-charged, liquid-cooled, 6-cylinder, diesel fueled, valve-in-head, vertical in-line four-cycle engine.



For basic theory of engine operation see FOS-30 "Engines" manual.

DIAGNOSING ENGINE MALFUNCTIONS

Will Not Start

Fuel System Malfunction—See Section 30

- Foreign matter in fuel
- Improper fuel
- Faulty fuel pump
- Fuel shut off at tank
- Restricted air intake system
- Faulty injection nozzles
- Plugged fuel filter

Electrical System Malfunction—See Section 40

- Corroded or loose battery
- Weak battery

Uneven Running or Frequent Stalling

Basic Engine Problem—See This Section

- Improper valve clearance
- Cylinder head gasket leaking
- Valves sticking or burned
- Worn or broken compression rings
- Low compression
- Incorrect timing
- Coolant temperature below normal
- Engine overheating

Service Problem—See Section 10

- Low fuel supply

Fuel System Malfunction—See Section 30

- Restricted fuel lines or filters
- Faulty fuel pump
- Faulty injection pump
- Faulty injection nozzles
- Exhaust system restricted

Engine Misses

Basic Engine Problem—See This Section

- Weak valve springs
- Incorrect valve clearance
- Burned, warped, pitted, or sticking valves
- Low compression
- Worn camshaft lobes (could be caused by faulty damper)
- Incorrect timing
- Engine overheating

Fuel System Malfunction—See Section 30

- Air in fuel
- Faulty injection nozzles
- Faulty injection pump
- Detonation
- Water in fuel
- Mixture of gasoline and diesel fuel

Lack of Power

Basic Engine Problem—See This Section

- Blown cylinder head gasket
- Worn camshaft lobes
- Incorrect valve clearance
- Incorrect valve timing
- Burned, warped, pitted or sticking valves
- Weak valve springs
- Low compression
- Incorrect timing
- Wrong viscosity crankcase oil
- Engine overheating

Service Problem—See Section 10

- Dirty or obstructed air cleaners
- Improper fuel
- Wrong oil viscosity

Fuel System Malfunction—See Section 30

- Plugged fuel filters
- Faulty injection pump
- Faulty injection nozzles
- Faulty fuel pump
- Restricted exhaust system
- Low intake manifold pressure
- Incorrect throttle linkage
- Plugged fuel tank vent

Power Train Malfunction—See Section 50

- Clutch slipping

Engine Overheats

Basic Engine Problem—See This Section

- Defective head gasket
- Incorrect engine timing
- Crankcase oil level low
- Low coolant level
- Radiator or side grille screen dirty
- Loose or broken fan belt
- Faulty thermostat
- Cooling system limed up
- Defective radiator pressure cap
- Faulty water pump

Service Problem—See Section 10

- Engine overloaded
- Crankcase oil level low
- Improper fuel

Fuel System Malfunction—See Section 30

- Excessive fuel delivery
- Improper injection pump timing

Excessive Oil Consumption

Basic Engine Problem—See This Section

- Restricted oil passage from valve cover
- Worn valve guides or valve stems
- Oil control rings worn or broken
- Scored liners or pistons
- Excessive ring groove wear in piston
- Rings sticking in grooves of piston
- Oil return holes in piston clogged
- Insufficient piston ring tension
- Piston ring gaps not staggered
- Worn crankshaft thrust bearing (misaligned piston and rod)
- Front or rear crankshaft oil seal faulty
- Crankcase oil too thin
- Oil pressure too high
- Oil level too high

Plugged oil cooler—oil or water passages

Service Problem—See Section 10

- Crankcase oil too thin
- Oil level too high

Fuel System Malfunction—See Section 30

- Restricted air intake system

Low Oil Pressure

Basic Engine Problem—See This Section

- Excessive main and connecting rod bearing clearance
- Low oil level
- Leakage at internal oil passages
- Faulty oil pump
- Improper regulating valve adjustment
- Improper oil
- Defective engine oil cooler

Service Problem—See Section 10

- Low oil level
- Improper oil

Electrical System Malfunction—See Section 40

- Defective oil pressure indicator lamp
- Faulty oil pressure sending unit

High Oil Pressure

Basic Engine Problem—See This Section

- Stuck or improperly adjusted regulating valve

Excessive Fuel Consumption

Basic Engine Problem—See This Section

- Low compression
- Incorrect engine timing

Service Problem—See Section 10

- Engine overloaded

Fuel System Malfunction—See Section 30

- Leaks in fuel system
- Restricted air cleaners
- Faulty injection pump
- Faulty injection nozzles

Black or Gray Exhaust Smoke

Basic Engine Problem—See This Section

- Incorrect engine timing

Service Problem—See Section 10

- Improper grade of fuel
- Engine overloaded

Fuel System Malfunction—See Section 30

- Excessive fuel delivery
- Faulty injection nozzles
- Restricted air cleaners
- Defective muffler
- Defective turbocharger

White Exhaust Smoke

Basic Engine Problem—See This Section
Low compression

Fuel System Malfunction—See Section 30
Faulty injection nozzles
Improper fuel

Slow Acceleration

Fuel System Malfunction—See Section 30
Faulty injection pump
Faulty injection nozzles

Detonation

Basic Engine Problem—See This Section
Carbon buildup in compression chambers

Fuel System Malfunction—See Section 30
Oil picked up by intake air stream
Faulty injection nozzles

Abnormal Engine Noise

Basic Engine Problem—See This Section
Excessive valve clearance
Worn cam followers
Bent push rods
Worn rocker arm shafts
Worn main or connecting rod bearings
Foreign material in combustion chamber
Worn piston pin bushings and pins
Scored piston
Incorrect engine timing
Excessive crankshaft end play
Loose main bearing caps
Worn timing gears
Worn oil pump gears
Broken pump shaft
Low engine oil level
Camshaft oil pump drive gear worn or broken



Suggest:

If the above button click is invalid.

Please download this document

first, and then click the above link

to download the complete manual.

Thank you so much for reading

Group 10

CYLINDER HEAD, VALVES, AND CAMSHAFT

GENERAL INFORMATION

The cylinder head is equipped with replaceable valve guides and valve seat inserts.

Dual valve springs for each valve reduce vibration and valve flutter. Valve rotators are installed at the bottom of the valve springs on both intake and exhaust valves.

The camshaft is supported by four pressure-lubricated bushings mounted in bores in the cylinder block. A thrust plate mounted on the front of the cylinder block takes up camshaft thrust.

DIAGNOSING MALFUNCTIONS

The following is a list of possible valve train malfunctions and causes:

Sticking Valves

- Carbon deposits on valve stem
- Worn valve guides
- Warped valve stems
- Cocked or broken valve springs
- Worn or distorted valve seats
- Insufficient lubrication

Warped, Worn, or Distorted Valve Guides

- Lack of lubrication
- Cylinder head distortion
- Excessive heat
- Unevenly tightened cylinder head cap screws

Distorted Cylinder Head and Cylinder Head Gasket Leakage

- Improperly tightened cylinder head cap screws
- Faulty gasket installation
- Excessive oil pressure
- Improper cylinder liner height above cylinder block

Worn or Broken Valve Seats

- Misaligned valves
- Distorted cylinder head
- Carbon deposits on seats due to incomplete combustion
- Valve spring tension too weak
- Excessive heat
- Improper valve clearance
- Improper valve timing

Camshaft Failures

- Scored camshaft lobes due to inadequate lubrication
- Excessive end play due to thrust plate wear
- Broken or warped camshaft due to improper timing

Burned, Pitted, Worn, or Broken Valves

- Worn or distorted valve seats
- Worn valve guides
- Insufficient cooling
- Insufficient lubrication
- Cocked or broken valve springs
- Detonation
- Improper engine operation
- Improper valve train timing
- Faulty valve rotators
- Warped or distorted valve stems
- "Stretched" valves due to excessive spring tension
- Distorted cylinder head
- Bent push rods
- Carbon build-up on valve seats
- Rocker arm failure

Check condition of other visible valve train parts for indication of malfunctions.

Prior to cylinder head removal, inspect and check engine operation.

Remove rocker arm cover. Check vent tube oil separator for clogging.

Check valve clearance. Intake valve clearance should be 0.018 inch. Exhaust valve clearance should be 0.028 inch.

<https://www.ebooklibonline.com>

Hello dear friend!

Thank you very much for reading.

Enter the link into your browser.

The full manual is available for immediate download.

<https://www.ebooklibonline.com>