

JOHN DEERE
WORLDWIDE COMMERCIAL & CONSUMER
EQUIPMENT DIVISION

Compact Utility Tractors
4210, 4310 and 4410

TM1985 DECEMBER 2002

TECHNICAL MANUAL



JOHN DEERE

North American Version
Litho in U.S.A. Litho in USA

INTRODUCTION

Manual Description

This technical manual is written for an experienced technician and contains sections that are specifically for this product. It is a part of a total product support program.

The manual is organized so that all the information on a particular system is kept together. The order of grouping is as follows:

- Table of Contents
- Specifications and Information
- Identification Numbers
- Tools and Materials
- Component Location
- Schematics and Harnesses
- Theory of Operation
- Operation and Diagnostics
- Diagnostics
- Tests and Adjustments
- Repair
- Other

NOTE: Depending on the particular section or system being covered, not all of the above groups may be used.

The bleed tabs for the pages of each section will align with the sections listed on this page. Page numbering is consecutive from the beginning of the Safety section through the last section.

We appreciate your input on this manual. If you find any errors or want to comment on the layout of the manual please contact us.

All information, illustrations and specifications in this manual are based on the latest information at the time of publication. The right is reserved to make changes at any time without notice.

COPYRIGHT© 2002
Deere & Co.
John Deere Worldwide Commercial and
Consumer Equipment Division
All rights reserved
Previous Editions
COPYRIGHT©

Safety

Specifications and Information

Engine

Electrical

Power Train (Gear)

Power Train (Hydro)

Power Train (ePRT)

Power Train (Final Drive)

Hydraulics

Steering

Brakes

Miscellaneous

SAFETY

Recognize Safety Information

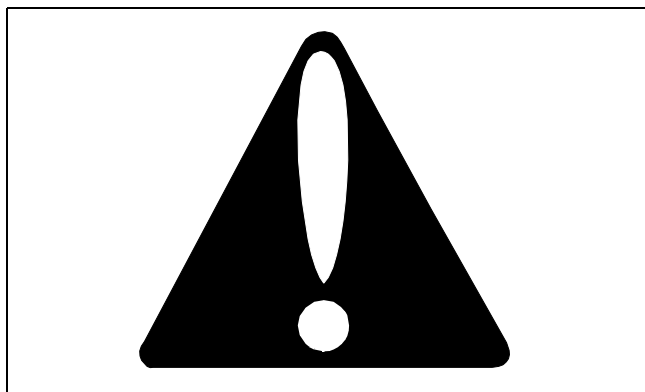

MIF

This is the safety-alert symbol. When you see this symbol on your machine or in this manual, be alert to the potential for personal injury.

Follow recommended precautions and safe servicing practices.

Understand Signal Words

A signal word - DANGER, WARNING, or CAUTION - is used with the safety-alert symbol. DANGER identifies the most serious hazards.

DANGER or WARNING safety signs are located near specific hazards. General precautions are listed on CAUTION safety signs. CAUTION also calls attention to safety messages in this manual.

Replace Safety Signs

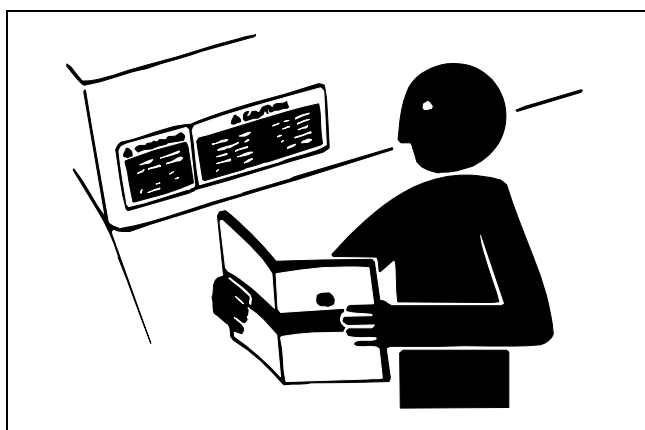

MIF

Replace missing or damaged safety signs. See the machine operator's manual for correct safety sign placement.

Handle Fluids Safely - Avoid Fires

Be Prepared For Emergencies

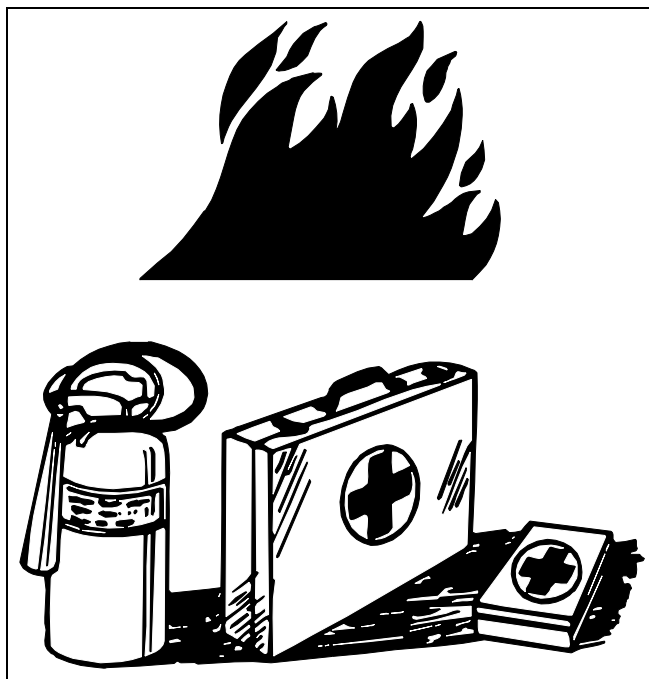

MIF

- When you work around fuel, do not smoke or work near heaters or other fire hazards.
- Store flammable fluids away from fire hazards. Do not incinerate or puncture pressurized containers.
- Make sure machine is clean of trash, grease, and debris.
- Do not store oily rags; they can ignite and burn spontaneously.
- Be prepared if a fire starts.
- Keep a first aid kit and fire extinguisher handy.
- Keep emergency numbers for doctors, ambulance service, hospital, and fire department near your telephone.

Use Care In Handling And Servicing Batteries

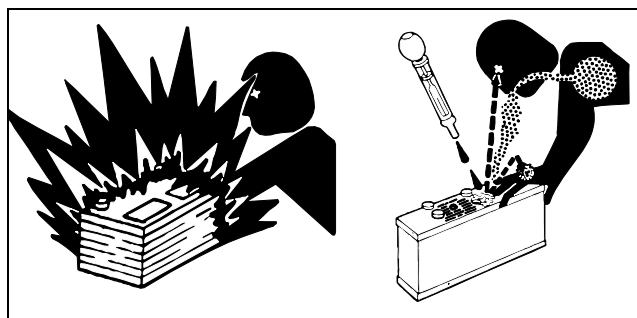

MIF

<https://www.ebooklibonline.com>

Hello dear friend!

Thank you very much for reading.

Enter the link into your browser.

The full manual is available for immediate download.

<https://www.ebooklibonline.com>

SAFETY

Prevent Battery Explosions

- Keep sparks, lighted matches, and open flame away from the top of battery. Battery gas can explode.
- Never check battery charge by placing a metal object across the posts. Use a volt-meter or hydrometer.
- Do not charge a frozen battery; it may explode. Warm battery to 16°C (60°F).

Prevent Acid Burns

- Sulfuric acid in battery electrolyte is poisonous. It is strong enough to burn skin, eat holes in clothing, and cause blindness if splashed into eyes.

Avoid acid burns by:

1. Filling batteries in a well-ventilated area.
2. Wearing eye protection and rubber gloves.
3. Avoiding breathing fumes when electrolyte is added.
4. Avoiding spilling or dripping electrolyte.
5. Use proper jump start procedure.

If you spill acid on yourself:

1. Flush your skin with water.
2. Apply baking soda or lime to help neutralize the acid.
3. Flush your eyes with water for 10 - 15 minutes.
4. Get medical attention immediately.

If acid is swallowed:

1. Drink large amounts of water or milk.
2. Then drink milk of magnesia, beaten eggs, or vegetable oil.
3. Get medical attention immediately.

Wear Protective Clothing

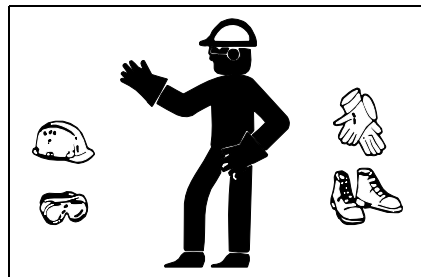

MIF

Wear close fitting clothing and safety equipment appropriate to the job.

Prolonged exposure to loud noise can cause impairment or loss of hearing. Wear a suitable hearing protective device such as earmuffs or earplugs to protect against objectionable or uncomfortable loud noises.

Operating equipment safely requires the full attention of the operator. Do not wear radio or music headphones while operating machine.

Use Care Around High-pressure Fluid Lines

Avoid High-Pressure Fluids



MIF

Escaping fluid under pressure can penetrate the skin causing serious injury.

Avoid injury from escaping fluid under pressure by stopping the engine and relieving pressure in the system before disconnecting or connecting hydraulic or other lines. Tighten all connections before applying pressure.

Search for leaks with a piece of cardboard. Protect hands and body from high pressure fluids.

If an accident occurs, see a doctor immediately. Any fluid injected into the skin must be surgically removed within a few hours or gangrene may result. Doctors unfamiliar with this type of injury should reference a knowledgeable medical source. Such information is available from Deere & Company Medical Department in Moline, Illinois, U.S.A.

SAFETY

Avoid Heating Near Pressurized Fluid Lines



MIF

Flammable spray can be generated by heating near pressurized fluid lines, resulting in severe burns to yourself and bystanders. Do not heat by welding, soldering, or using a torch near pressurized fluid lines or other flammable materials. Pressurized lines can be accidentally cut when heat goes beyond the immediate flame area.

Service Machines Safely

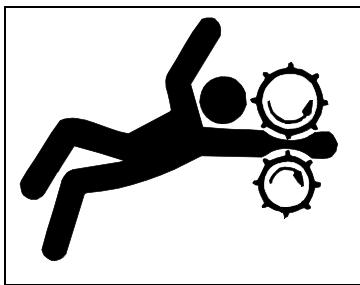

MIF

Tie long hair behind your head. Do not wear a necktie, scarf, loose clothing, or necklace when you work near machine tools or moving parts. If these items were to get caught, severe injury could result.

Remove rings and other jewelry to prevent electrical shorts and entanglement in moving parts.

Use Proper Tools

Use tools appropriate to the work. Makeshift tools and procedures can create safety hazards. Use power tools only to loosen threaded parts and fasteners. For loosening and tightening hardware, use the correct size tools. **DO NOT** use U.S. measurement tools on metric fasteners. Avoid bodily injury caused by slipping wrenches. Use only service parts meeting John Deere specifications.

Park Machine Safely

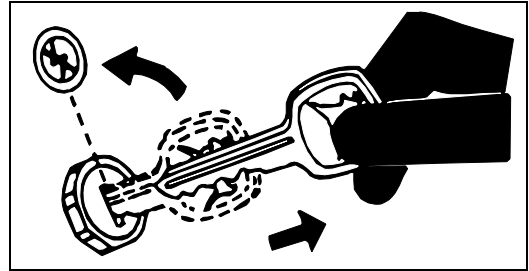

MIF

Before working on the machine:

1. Lower all equipment to the ground.
2. Stop the engine and remove the key.
3. Disconnect the battery ground strap.
4. Hang a "DO NOT OPERATE" tag in operator station.

Support Machine Properly And Use Proper Lifting Equipment

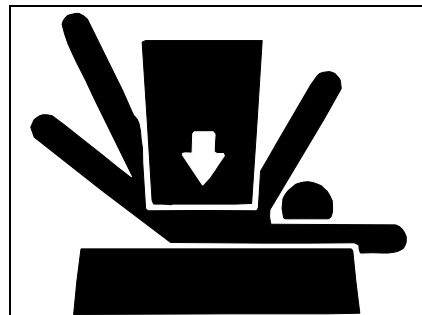

MIF

If you must work on a lifted machine or attachment, securely support the machine or attachment.

Do not support the machine on cinder blocks, hollow tiles, or props that may crumble under continuous load. Do not work under a machine that is supported solely by a jack. Follow recommended procedures in this manual.

Lifting heavy components incorrectly can cause severe injury or machine damage. Follow recommended procedure for removal and installation of components in the manual.

Work In Clean Area

Before starting a job:

1. Clean work area and machine.
2. Make sure you have all necessary tools to do your job.
3. Have the right parts on hand.
4. Read all instructions thoroughly; do not attempt shortcuts.

SAFETY

Using High Pressure Washers

Directing pressurized water at electronic/electrical components or connectors, bearings, hydraulic seals, fuel injection pumps or other sensitive parts and components may cause product malfunctions. Reduce pressure and spray at a 45 to 90 degree angle.

Illuminate Work Area Safely

Illuminate your work area adequately but safely. Use a portable safety light for working inside or under the machine. Make sure the bulb is enclosed by a wire cage. The hot filament of an accidentally broken bulb can ignite spilled fuel or oil.

Work In Ventilated Area

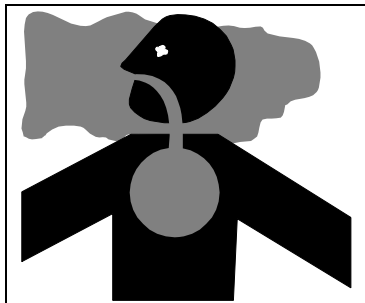

MIF

Engine exhaust fumes can cause sickness or death. If it is necessary to run an engine in an enclosed area, remove the exhaust fumes from the area with an exhaust pipe extension.

If you do not have an exhaust pipe extension, open the doors and get outside air into the area.

Warning: California Proposition 65 Warning

Gasoline engine exhaust from this product contains chemicals known to the State of California to cause cancer, birth defects, or other reproductive harm.

Diesel engine exhaust and some of its constituents are known to the State of California to cause cancer, birth defects, and other reproductive harm.

Remove Paint Before Welding Or Heating

Avoid potentially toxic fumes and dust. Hazardous fumes can be generated when paint is heated by welding, soldering, or using a torch. Do all work outside or in a well ventilated area. Dispose of paint and solvent properly. Remove paint before welding or heating: If you sand or grind paint, avoid breathing the dust. Wear an approved respirator. If you use solvent or paint stripper, remove stripper with soap and water before welding. Remove

solvent or paint stripper containers and other flammable material from area. Allow fumes to disperse at least 15 minutes before welding or heating.

Avoid Harmful Asbestos Dust

Avoid breathing dust that may be generated when handling components containing asbestos fibers. Inhaled asbestos fibers may cause lung cancer.

Components in products that may contain asbestos fibers are brake pads, brake band and lining assemblies, clutch plates, and some gaskets. The asbestos used in these components is usually found in a resin or sealed in some way. Normal handling is not hazardous as long as airborne dust containing asbestos is not generated.

Avoid creating dust. Never use compressed air for cleaning. Avoid brushing or grinding material containing asbestos. When servicing, wear an approved respirator. A special vacuum cleaner is recommended to clean asbestos. If not available, apply a mist of oil or water on the material containing asbestos. Keep bystanders away from the area.

Service Tires Safely

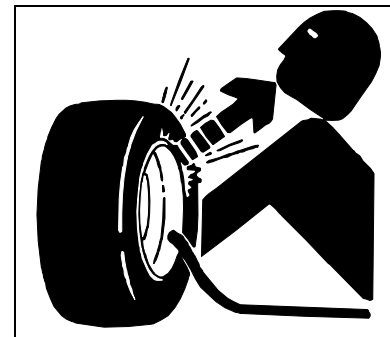

MIF

Explosive separation of a tire and rim parts can cause serious injury or death.

Do not attempt to mount a tire unless you have the proper equipment and experience to perform the job.

Always maintain the correct tire pressure. Do not inflate the tires above the recommended pressure. Never weld or heat a wheel and tire assembly. The heat can cause an increase in air pressure resulting in a tire explosion. Welding can structurally weaken or deform the wheel.

When inflating tires, use a clip-on chuck and extension hose long enough to allow you to stand to one side and NOT in front of or over the tire assembly. Use a safety cage if available.

Check wheels for low pressure, cuts, bubbles, damaged rims or missing lug bolts and nuts.

ENGINE - DIESEL TABLE OF CONTENTS

Table of Contents	
Specifications25	Rocker Arm Assembly 58
General Specifications25	Cylinder Head and Valves
Repair Specifications.....26	Removal and Installation 60
Tests and Adjustment Specifications31	Cylinder Head and Valves
Operational Tests31	Disassembly and Assembly..... 61
Torque Values, Non-Standard Fasteners.....32	Valve Seats..... 62
Special Tools32	Valve Recession 64
Other Materials32	Valve Guides 64
Theory of Operation33	Valve Springs..... 65
Fuel and Air System Operation33	Exhaust Manifold 65
Cooling System Operation34	Intake Manifold 65
Lubrication System Operation35	Grind Valve Seats..... 66
Diagnostics36	Lap Valves 66
Engine Troubleshooting36	Measure Piston-To-Cylinder Head
Diagnostic Table.....41	Clearance 66
Tests and Adjustments43	Piston and Connecting Rod 67
Cylinder Compression Test43	Piston Inspection 70
Slow Idle Adjustment.....44	Cylinder Bore 73
Valve Clearance Adjustment44	Crankshaft Rear Oil Seal 75
Connecting Rod Side Play Check46	Crankshaft Front Oil Seal 75
Connecting Rod Bearing	Crankshaft and Main Bearings 75
Clearance Check.....46	Flywheel and Coupling 78
Crankshaft End Play Check47	Camshaft 79
Crankshaft Main Bearing	Camshaft Followers 81
Clearance Check.....47	Timing Gear Cover 83
Valve Lift Check48	Idler Gear..... 84
Camshaft End Play Check49	Timing Gear Cover Mounting Plate 85
Timing Gear Backlash Check.....49	Oil Pan and Strainer 85
Fuel Injection Nozzle Test49	Oil Pump 85
Thermostat Opening Test.....51	Thermostat and Water Pump..... 86
Injection Pump Static Timing Adjustment.....51	Fuel Filter Assembly 88
Injection Pump Timing	Component Location Fuel Supply..... 89
Adjustment (EPA Engines).....53	Fuel Injection Pump 90
Fan/Alternator Drive Belt Adjustment53	Fuel Injection Nozzles..... 92
Radiator Bubble Test.....53	Starting Motor Removal and Installation..... 95
Cooling System Pressure Test.....54	Starting Motor
Radiator Pressure Cap Test.....54	Disassembly and Assembly..... 96
Engine Oil Pressure Test55	Starting Motor Inspection/Test..... 98
Fuel Transfer Pump Tests.....55	Starting Motor Gear Train 99
Fuel System Leakage Test.....56	Starting Motor Solenoid 101
Bleed Fuel System56	Alternator Removal and Installation..... 102
Repair.....57	Alternator Disassembly..... 102
Engine Removal57	Alternator Components..... 105
Rocker Cover Removal and Installation58	

ENGINE - DIESEL TESTS AND ADJUSTMENTS

Slow Idle Adjustment

IMPORTANT: Avoid damage! The slow idle adjustment is the only adjustment that can be made on this engine.

The fast idle and torque capsule adjustments are pre-set by the engine manufacturer to comply with strict EPA/CARB emissions requirements, and are adjustable **ONLY** by authorized diesel service facilities.

Reason:

To achieve proper slow idle rpm setting. Provides adequate rpm to keep the engine running smoothly without stalling.

Equipment:

- JT05719 Hand Held Digital Tachometer

NOTE: Make sure the air cleaner is clean and not restricted. Replace the air cleaner element as necessary.

Procedure:

1. Place a small piece of reflective tape on the crankshaft pulley.
2. Start the engine and run for 5 minutes to attain operating temperature.
3. Move the throttle lever to slow idle position.
4. Use JT05719 Hand Held Digital Tachometer to check engine speed at the crankshaft pulley.
5. Visually check that the injection pump throttle lever is against slow idle stop screw. Slow idle speed is set to specification.

Specifications:

SST and ePowrReverser Machines 950 ± 50 rpm
eHydro Machines 1000 ± 50 rpm

Results:

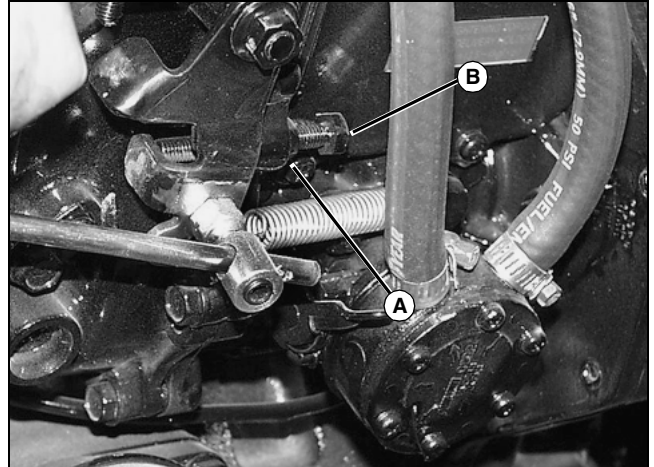

MX9887

- If the slow idle rpm is not according to specifications, loosen the nut (A) and turn the slow idle stop screw (B) clockwise to increase the engine speed, or counterclockwise to decrease the engine speed until the slow idle speed is correct. After adjustment, tighten the nut.

Valve Clearance Adjustment

Reason:

To be sure the valves are fully opening and closing at the correct time, and not wearing the valve train unnecessarily.

Equipment:

- Feeler Gauge
- 10 mm End Wrench
- Flat Blade Screwdriver
- 17 mm Wrench

Procedure:

1. The engine must be cool (room temperature) before the valve clearance is checked.
2. Be sure ignition key is OFF before attempting to turn engine by hand.
3. Open the hood and remove the engine side covers.
4. Remove the rocker arm cover. See "Rocker Cover Removal and Installation" on page 58.

ENGINE - DIESEL TESTS AND ADJUSTMENTS

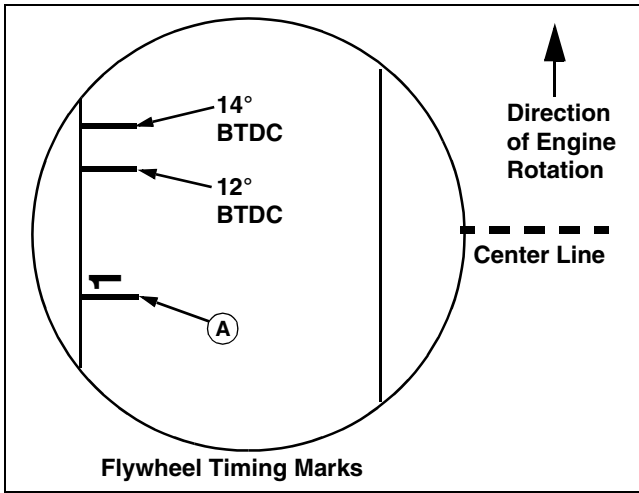

MIF

5. Locate the inspection hole in right side of the transmission tunnel. The flywheel can be seen inside the inspection hole.

NOTE: "Top dead center (TDC)" is when the piston is at its' highest point of travel in the cylinder on the compression stroke.

Number one cylinder is located at rear of engine (flywheel side).

6. Turn the crankshaft pulley while watching the flywheel inside the inspection hole. Align the number one TDC mark (A) on the flywheel with the pointer on the tunnel.

NOTE: When top dead center is reached, the rocker arms for that cylinder will be motionless as the crankshaft if rotated. If rocker arms are still moving when TDC is approached, rotate crankshaft one full revolution and try again.

7. Try to move rocker arms and/or push rods for No. 1 cylinder:

- If the rocker arms and push rods are loose, the piston is at TDC on the compression stroke. Go to step 8.
- If the rocker arms and/or push rods are not loose, rotate the flywheel one revolution (360°), and recheck the rocker arms and push rods.

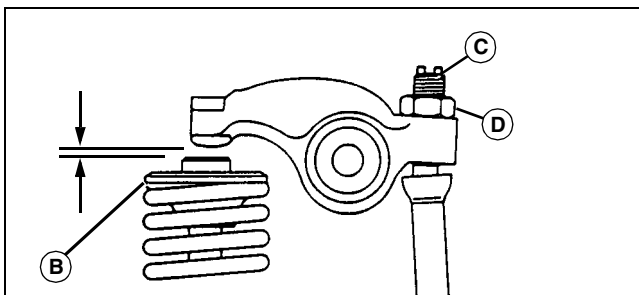

MX1194

8. Slide a feeler gauge between the valve cap (B) and rocker arm to measure the clearance.

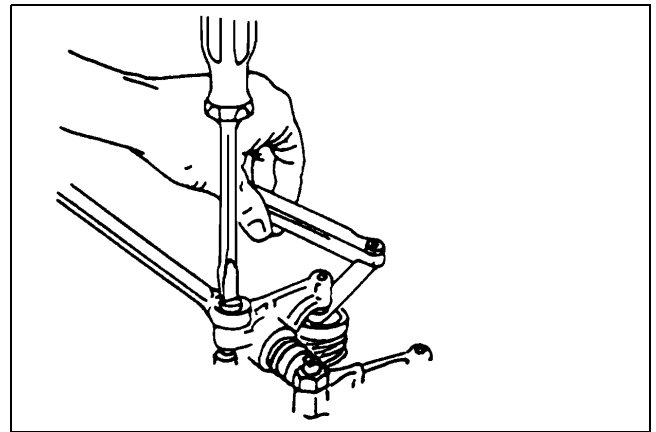

T6105BF

9. To adjust the valves, loosen the lock nut (D) and turn the adjusting screw (C) until the blade of the feeler gauge can be inserted between the rocker arm and valve cap. Hold the adjusting screw while tightening the lock nut.

10. Recheck the valve clearance after tightening the lock nut.

Specification:

Valve Clearance 0.15 - 0.25 mm (0.006 - 0.010 in.)

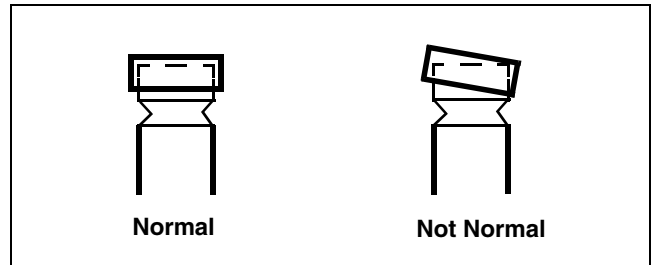

MIF

11. Check that the valve cap on the valve stem remained seated on the valve and inside the valve spring retainer.

12. Turn the crankshaft pulley counter clockwise (as viewed from operator's seat or flywheel end) approximately 2/3 of a revolution (240°) while watching the observation hole for the number three timing mark.

13. Check that the rocker arms and push rods for cylinder number three are loose.

14. Repeat steps 7 - 13 for number three cylinder.

15. Repeat steps 7 - 11 for number two cylinder.

16. Replace the rocker arm cover, air cleaner bracket and housing, and the muffler.

17. Replace the engine side covers and hood.

ENGINE - DIESEL TESTS AND ADJUSTMENTS

Connecting Rod Side Play Check

Reason:

To determine proper side clearance between the crankshaft and the connecting rod.

Equipment:

- Feeler Gauge

NOTE: The engine must be removed from the machine to perform this test.

Procedure:

1. Remove the oil pan, crankcase extension, oil pick-up, and balancer assembly.
2. Insert a feeler gauge, according to specifications, between the connecting rod cap and the crankshaft.

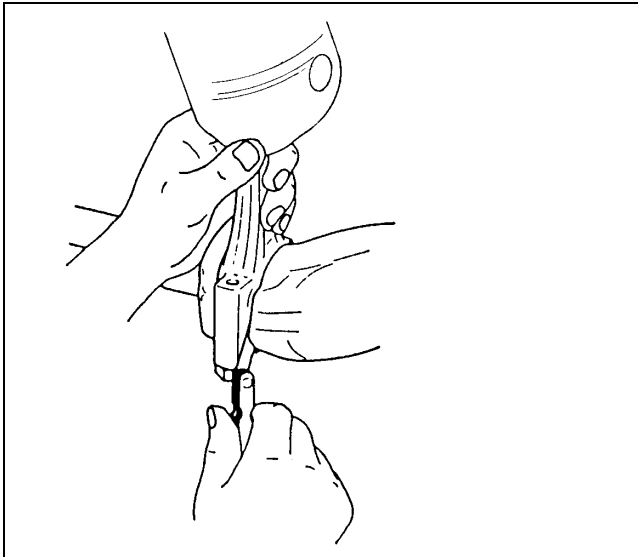

M82116A

3. Connecting rod side play is **0.2 - 0.4 mm (0.008 - 0.016 in.)**.

Results:

- If the side play exceeds specification, replace the bearing inserts or the connecting rod.

Connecting Rod Bearing Clearance Check

Reason:

To measure oil clearance between connecting rod bearing and crankshaft journal.

Equipment:

- PLASTIGAGE®

NOTE: The engine must be removed from the machine to perform this procedure.

Procedure:

1. Remove the oil pan, and oil pickup.

IMPORTANT: Avoid damage! The connecting rod caps must be installed on the same connecting rod and in the same direction to prevent crankshaft and connecting rod damage.

2. Remove the connecting rod cap.
3. Wipe oil from the bearing insert and the crankshaft journal.
4. Put a piece of PLASTIGAGE® (A), or an equivalent, along the full length of the bearing insert approximately **6 mm (0.25 in.)** off center.

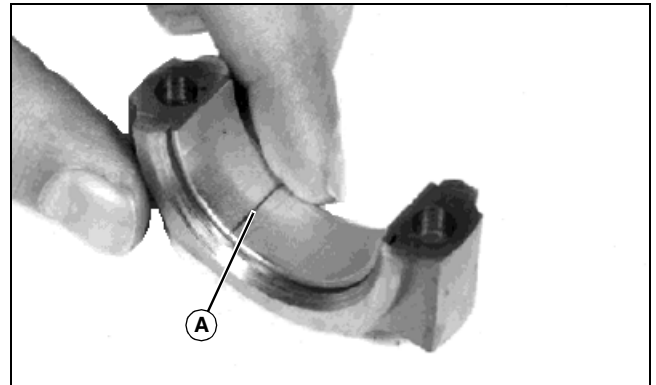

M35351

5. Turn the crankshaft approximately 30° from bottom dead center.
6. Install the connecting rod end cap and original rod bolts. Tighten the rod bolts to specification.

Specifications:

Connecting Rod Bolt Torque

4210	37 - 41 N•m (27 - 30 lb-ft)
4310, 4410	44 - 54 N•m (33 - 40 lb-ft)

7. Remove the rod bolts and the connecting rod cap.

NOTE: The flattened PLASTIGAGE® (A) will be found on either the bearing insert or crankshaft journal.

8. Use the graduation marks on the envelope (C) to compare the width of the flattened PLASTIGAGE at its widest point. The number within the graduation marks indicates the bearing clearance in inches or millimeters depending on which side of the envelope is used.

ENGINE - DIESEL TESTS AND ADJUSTMENTS

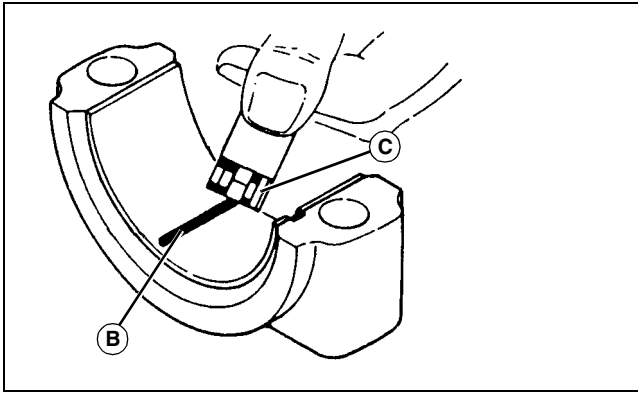

M82117A

9. Measure the connecting rod bearing oil clearance.

Specification:

Connecting Rod Bearing Oil Clearance

4210 0.04 - 0.09 mm (0.002 - 0.004 in.)

Wear Limit 0.25 mm (0.010 in.)

4310, 4410 0.04 - 0.07 mm (0.002 - 0.003 in.)

Wear Limit 0.16 mm (0.006 in.)

Results:

- If the clearance exceeds the wear limit specification, replace the bearing inserts.
- Remove the PLASTIGAGE®.

Crankshaft End Play Check

Reason:

To determine proper side clearance between the crankshaft and the engine block.

Equipment:

- Dial Indicator

Procedure:

NOTE: Crankshaft end play can be measured at front end or rear end of crankshaft. Procedure is performed from the rear end. The flywheel is removed to show detail.

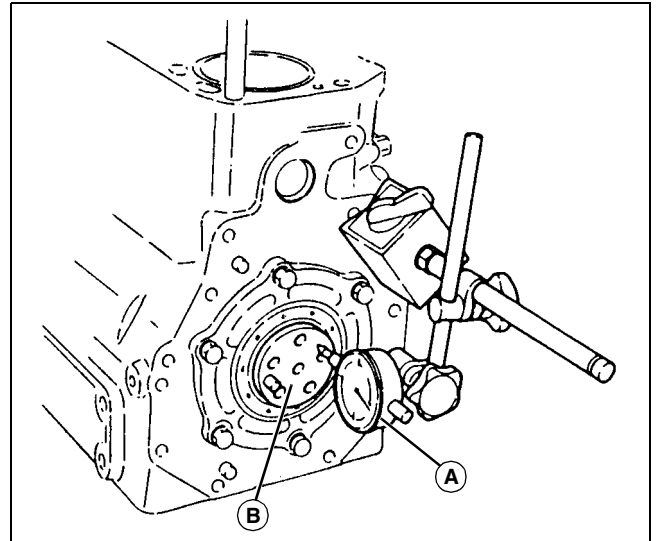

M82118A

1. Fasten the dial indicator (B) to engine and position indicator tip on end of crankshaft (A).

IMPORTANT: Avoid damage! Do not use excessive force when moving crankshaft to avoid damaging bearings.

2. Push the crankshaft toward rear as far as possible.
3. Zero the dial indicator.
4. Using a bar, gently pry the crankshaft as far forward as possible.
5. Crank shaft end play is **0.09 - 0.27 mm (0.004 - 0.011 in.)**.

Results:

- If the end play exceeds **0.27 mm (0.011 in.)**, replace the thrust bearings.

Crankshaft Main Bearing Clearance Check

Reason:

To measure oil clearance between main bearing and crankshaft journal.

Equipment:

- PLASTIGAGE®

NOTE: The engine must be removed from the machine to perform this test.

Procedure:

1. Remove the oil pan, and oil pickup.

ENGINE - DIESEL TESTS AND ADJUSTMENTS

IMPORTANT: Avoid damage! Main bearing caps must be installed on the same main bearing and in the same direction to prevent crankshaft and main bearing damage.

2. Remove the main bearing cap.
3. Wipe oil from the bearing insert and the crankshaft journal.

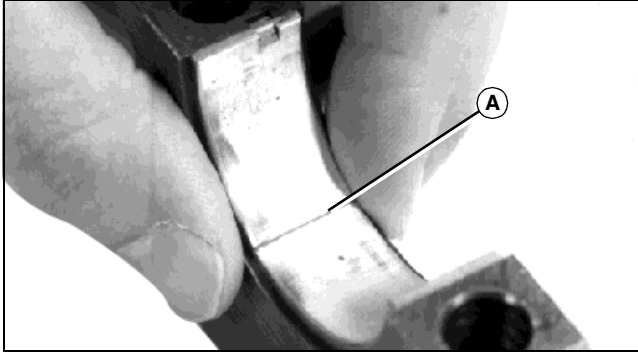

M35382

4. Put a piece of PLASTIGAGE® (A), or an equivalent, along the full length of the bearing insert approximately **6 mm (0.25 in.)** off center.
5. Install the main bearing cap and bolts. Tighten the bolts to specification.

Specification:

Main Bearing Bolt Torque

4210 76.5 - 80.4 N•m (56 - 59 lb-ft)
4310, 4410 96 - 100 N•m (71 - 74 lb-ft)

6. Remove the bolts and main bearing caps.

NOTE: The flattened PLASTIGAGE® (B) will be found on either the bearing insert or crankshaft journal.

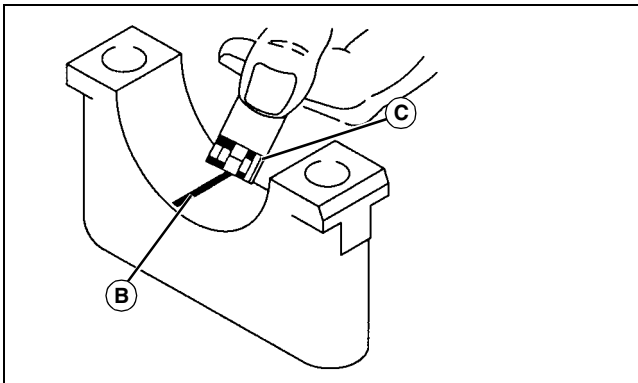

M82119A

7. Use the graduation marks (C) on the envelope to compare the width of the flattened PLASTIGAGE® at its widest point. The number within the graduation marks indicates the bearing clearance in inches or millimeters, depending on which side of the envelope is used.

Specification:

Main Bearing Oil Clearance

4210 0.04 - 0.09 mm (0.002 - 0.004 in.)

Wear Limit 0.25 mm (0.010 in.)

4310, 4410 0.04 - 0.07 mm (0.002 - 0.003 in.)

Wear Limit 0.16 mm (0.006 in.)

Results:

- If the clearance exceeds the wear limit specification, replace the bearing inserts.
- Remove PLASTIGAGE®.

®PLASTIGAGE is a registered trademark of the DANA Corporation.

Valve Lift Check

Reason:

Check wear on cam lobes, followers, and/or push rods.

Equipment:

- Dial Indicator

Procedure:

1. Remove the rocker arm cover. See "Rocker Cover Removal and Installation" on page 58.
2. Adjust the valve clearance.

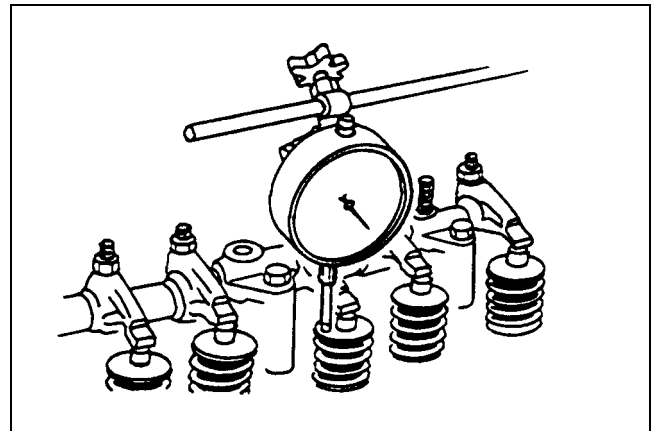

T6333DT

3. Fasten the dial indicator to the engine and position the indicator tip on the valve retainer. The valve must be fully closed and the rocker arm must move freely.
4. Zero the dial indicator.
5. Manually turn the crankshaft pulley clockwise (from the fan end).
6. Observe the dial indicator as the valve is moved to the full open position. Repeat for each valve.

ENGINE - DIESEL TESTS AND ADJUSTMENTS

Results:

- The valve lift should be the same for all valves. If one or more valves have less travel than the others, remove and inspect the camshaft, followers and push rods. See “Camshaft” on page 79. If the camshaft, followers and push rods are within specification remove and inspect the cylinder head. See “Cylinder Head and Valves Removal and Installation” on page 60.

Camshaft End Play Check

Reason:

To determine proper side clearance between camshaft gear end journal and thrust plate.

Equipment:

- Dial Indicator

Procedure:

1. Remove the timing gear cover. See “Timing Gear Cover” on page 83.
2. Fasten the dial indicator to the engine and position indicator tip on end of camshaft.
3. Push the camshaft toward the rear as far as possible.
4. Zero the dial indicator.
5. Pull the camshaft forward as far as possible.

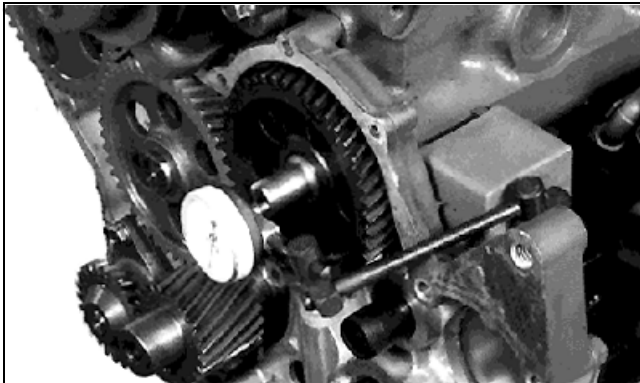

M37512

6. Standard end play is **0.05 - 0.25 mm (0.002 - 0.010 in.)**.

Results:

- If the end play exceeds **0.25 mm (0.010 in.)**, remove the camshaft and replace the thrust plate.

Timing Gear Backlash Check

Reason:

To check for wear between meshing gears, resulting in excessive noise and poor engine performance.

Equipment:

- Dial Indicator

Procedure:

1. Measure the backlash between meshing gears.
2. The backlash for all gears EXCEPT the oil pump gear is **0.07 - 0.15 mm (0.003 - 0.006 in.)**.
3. The backlash for the oil pump gear is **0.11 - 0.19 mm (0.004 - 0.008 in.)**.

Results:

- If the backlash exceeds specifications, replace meshing gears as a set:

Idle Gear, Camshaft Gear, Crankshaft Gear, Oil Pump Gear AND/OR Idle Gear, Fuel Injection Pump Gear.

Fuel Injection Nozzle Test



CAUTION: Avoid Injury! Escaping fluid under pressure can penetrate the skin causing serious injury. Avoid the hazard by relieving pressure before disconnecting hydraulic or other lines. Tighten all connections before applying pressure. Search for leaks with a piece of cardboard. Protect hands and body from high pressure fluids.

If an accident occurs, see a doctor immediately. Any fluid injected into the skin must be surgically removed within a few hours or gangrene may result. Doctors unfamiliar with this type of injury should reference a knowledgeable source. Such information is available from the Deere & Company Medical Department in Moline, Illinois, U.S.A.

Reason:

To determine opening pressure, leakage, chatter and spray pattern of the fuel injection nozzle.

Equipment:

- D01110AA Adapter Set
- D01109AA Diesel Fuel Injection Nozzle Tester

ENGINE - DIESEL TESTS AND ADJUSTMENTS

- 23622 Straight Adapter

- Container

Connections:

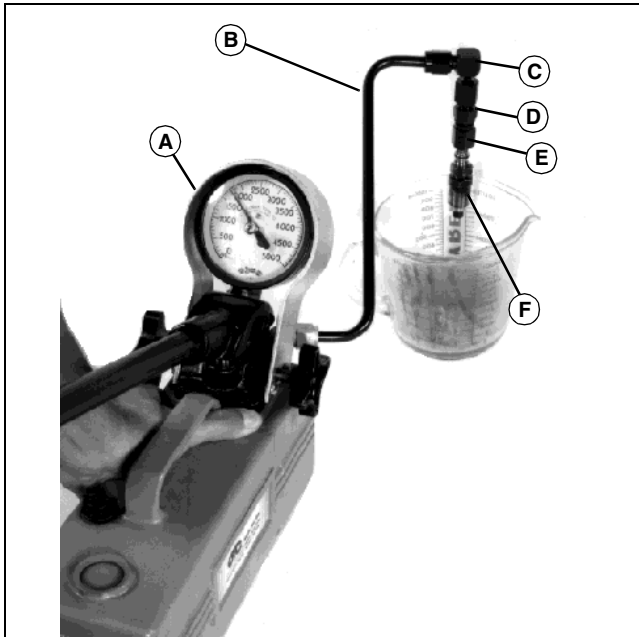

M35913

1. Connect the fuel injection nozzle (F) to D01109AA Diesel Fuel Injection Nozzle Tester (A) using parts 36352 (B), 23617 (C), 23621 (D) from D01110AA Adapter Set, and 23622 straight adapter.

IMPORTANT: Avoid damage! Use clean filtered diesel fuel when testing injection nozzles to get best test results.

Procedure 1:

Test the fuel injection nozzle opening pressure following the Nozzle Tester manufacturer's instructions.

The opening pressure is **19600 + 1000/-0 kPa (2843 + 145/-0 psi)**.

Results:

- If the pressure reading does not meet specification, disassemble the injection nozzle and inspect for contamination or a stuck valve. If necessary, add or remove shims to change opening pressure.

Procedure 2:

Test fuel injection nozzle leakage following the nozzle tester manufacturer's instructions.

1. Dry the nozzle completely using a lint-free cloth.
2. Pressurize the nozzle to **19600 kPa (2843 psi)**.
3. Watch for leakage from nozzle spray orifice.

Results:

- Fuel should not leak from the nozzle when the nozzle is pressurized.
- If the injection nozzle leaks fuel, disassemble and inspect the nozzle assembly for contamination. Inspect the valve seating surface. Replace the nozzle assembly if necessary.

Procedure 3:

Test the fuel injection nozzle chatter and spray pattern following the nozzle tester manufacturer's instructions.

1. Pressurize nozzle to **19600 kPa (2843 psi)**.
2. With slow hand lever movement there should be a "chatter" sound.
3. With fast hand lever movement the nozzle should exhibit an even, fine atomized spray pattern (G).
4. Place a sheet of white paper **30 cm (12 in.)** below the nozzle. The injection spray should form a perfect circle on the paper.

Results:

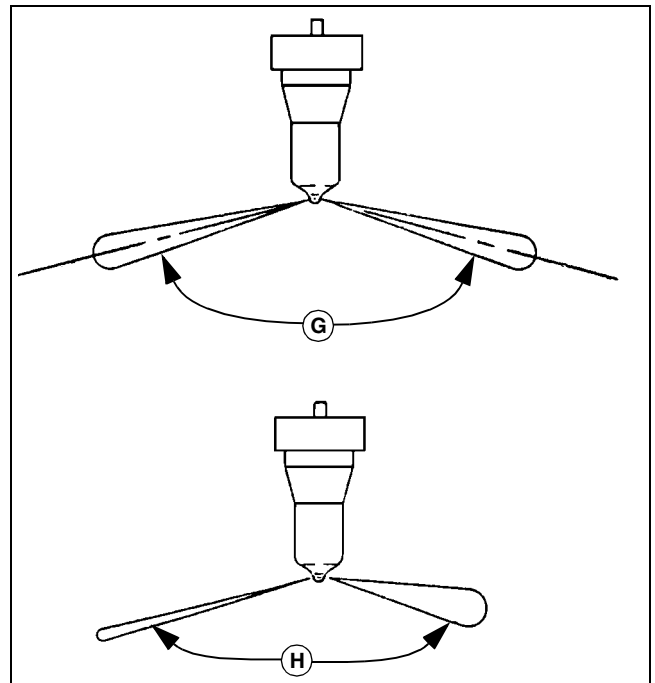

M82121A

- If nozzle chatter or the spray pattern does not meet specifications, disassemble the injection nozzle and inspect the nozzle assembly for contamination. Inspect the valve seating surface. Replace the nozzle assembly if necessary.
- If there is excessive difference in the spray angle or injection angle, incomplete atomizing or sluggish starting/stopping of injection (H), disassemble the injection nozzle and inspect the nozzle assembly for contamination. Replace the nozzle assembly if necessary.

ENGINE - DIESEL TESTS AND ADJUSTMENTS

Thermostat Opening Test

Reason:

To determine opening temperature of thermostat.

Equipment:

- Thermometer
- Glass Container
- Heating Unit

Procedure:



CAUTION: Avoid Injury! DO NOT allow thermostat or thermometer to rest against the side or bottom of glass container when heating water. Either may rupture if overheated.

1. Suspend the thermostat and a thermometer in a container of water.
2. Heat and stir the water. Observe the opening action of the thermostat as the water heats up.
3. Remove the thermostat and observe the closing action as it cools.

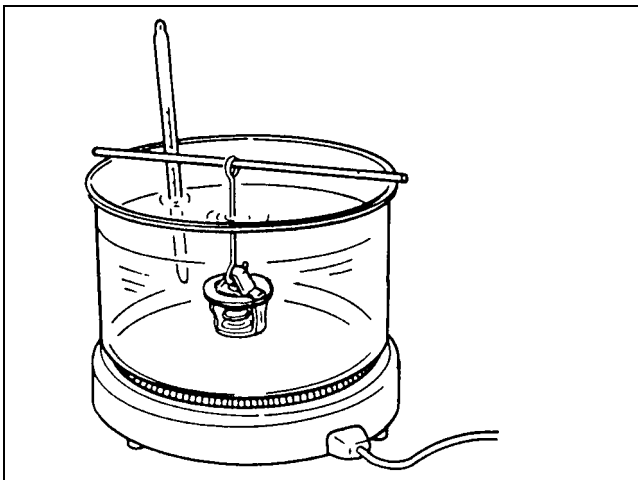

M82122A

Results:

- The thermostat should begin opening at **69.5 - 72.5° C (157 - 163° F)** and be fully open at **85° C (185° F)**.
- Replace the thermostat if the fully open lift height is less than **8 mm (0.31 in.)**, or if the closing action is not smooth and slow.

Injection Pump Static Timing Adjustment

Reason:

To make sure that the injection pump timing is set to manufacturers specification.

Equipment:

- Timing Tool (Made from high pressure pipe, nut and a clear plastic straw**)
- ** straw from WD40, carburetor cleaner, brake parts cleaner, etc.
- External fuel supply

Procedure:

IMPORTANT: Avoid damage! The injection pump timing should be correct. The timing is set at the factory, and will not normally change during the life of the engine. Check and adjust the timing only as the last option, or if there is reason to believe the timing has been altered. Check the fuel, fuel supply system, injectors, air intake system and cylinder compression before continuing.

NOTE: If the injection pump has been removed from engine without disturbing engine crankshaft and pump gear, perform step 1 to obtain a close starting point, then perform the entire timing procedure.

1. Align the arrow or line on the injection pump flange on the mark noted during pump removal.

NOTE: Normal rotation, as viewed from the flywheel end, is counterclockwise. The number one fuel injection line is toward the flywheel.

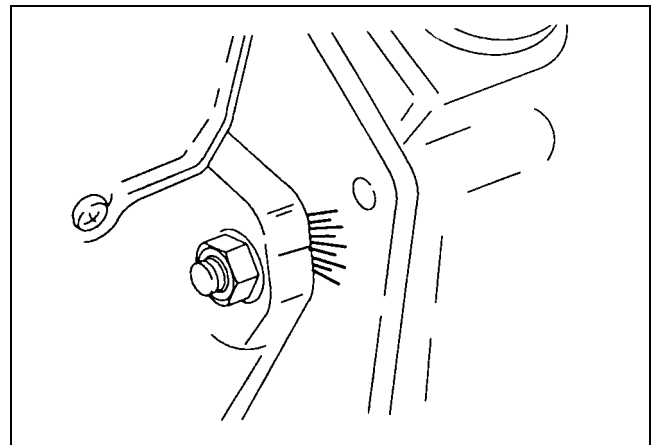

M57132

2. Remove the number one fuel injection line.

ENGINE - DIESEL TESTS AND ADJUSTMENTS

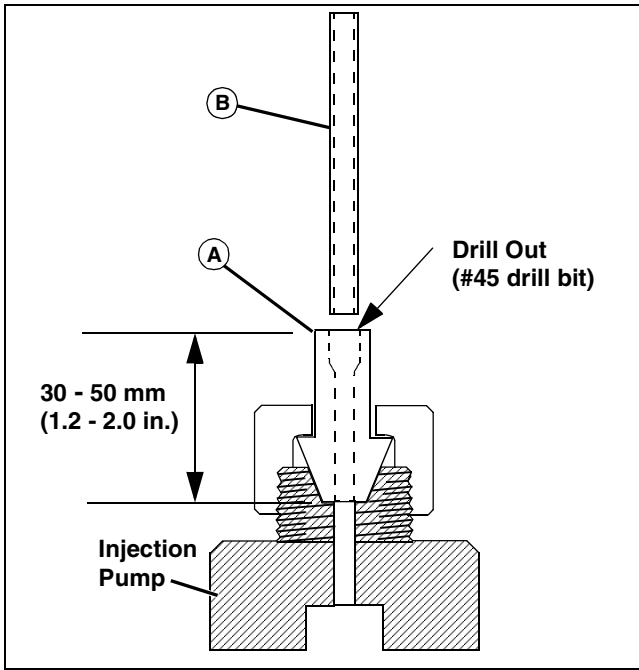

MIF

3. Install the timing tool (A) and clear straw (B).
4. Remove the access panel from the flywheel housing.
5. Prime the pump to fill it with fuel.
6. Disconnect battery negative (-) terminal and remove fuel shutoff solenoid.
7. Turn the flywheel counterclockwise (as viewed from the flywheel end) until the timing tool straw has fuel showing.

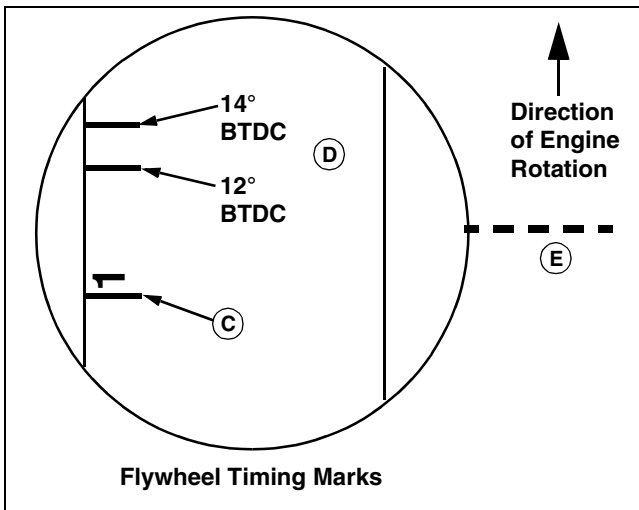

MIF

8. Turn the crankshaft pulley clockwise (back) until the No. 1 cylinder top dead center (TDC) mark (C) and pump timing marks (D) have gone past the center of the timing hole in the flywheel housing (E) by at least 50 mm (2 in.).
9. Snap the straw with your finger until the level of the fuel, or a bubble, is set part way up the straw. This will be the point to watch for fuel movement.

10. Slowly turn the flywheel counterclockwise (as viewed from the flywheel end) until the fuel in the straw just starts to move. Stop rotating the flywheel the instant the fuel begins to move.

NOTE: If there is no fuel movement, engine may be on exhaust stroke. Rotate flywheel 360° and repeat test.

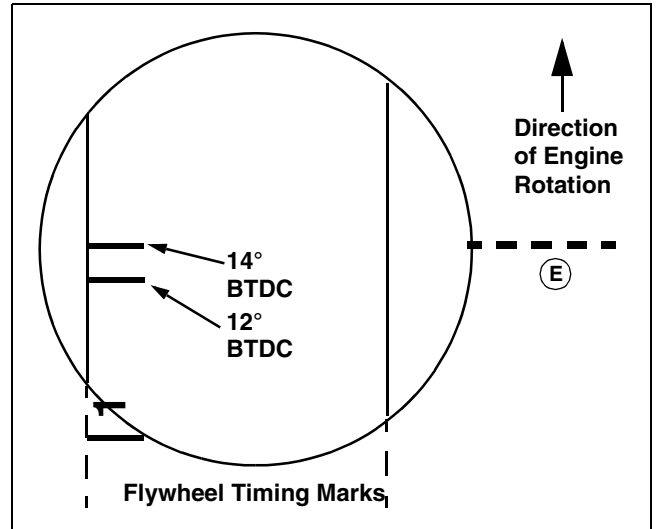

MIF

11. Check the injection pump timing marks on the flywheel. The 14° mark on the flywheel must line up with the center of the timing hole (E) in the flywheel housing.

Results:

- If the timing is not within specifications, loosen the pump mounting bolts and turn the pump toward the engine block to retard the timing or away from the block to advance the timing. Recheck the timing. If the timing did not change, remove pump and have tested by an authorized diesel injection service shop.
- If the timing is correct, remove timing tool, install number one injection line, install the access cover to the flywheel housing.

ENGINE - DIESEL TESTS AND ADJUSTMENTS

Injection Pump Timing Adjustment (EPA Engines)

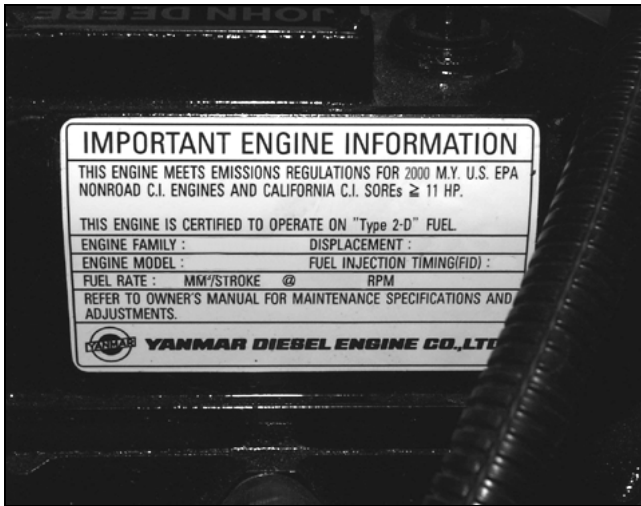

MX1339A

EPA engines have EPA compliance sticker on rocker arm cover as shown above.



CAUTION: Avoid Injury! DO NOT attempt to adjust the fuel injection pump timing. For most engine problems, the fuel injection pump timing will not have to be adjusted. If the engine performed well at one time, then performance dropped, the fuel injection timing is NOT the problem. Fuel injection timing, once set by the engine manufacturer, should NOT change during the life of the engine.

IMPORTANT: Avoid damage! Fuel injection pump timing should NOT change during the life of the engine unless the pump has been altered illegally, or there is excessive wear to the camshaft injection pump cam lobes and lifters.

First check the fuel quality, fuel supply, fuel injectors, air intake system, and engine compression in all cylinders before considering fuel injection timing problems.

If all other possibilities have been ruled out and it is determined that the fuel injection pump and governor assembly are in need of repair, they must be replaced ONLY as complete assemblies.

Only an authorized factory trained technician is allowed to remove and install these assemblies

Fan/Alternator Drive Belt Adjustment

Reason:

To keep proper tension on the belt to drive the water pump and the alternator. To prevent shortened belt and bearing life.

Equipment:

- JDG529 or JDST28 Belt Tension Gauge
- Straight Edge

Procedure:

1. Check the belt tension between the fan and alternator using a belt tension gauge and a straight edge.

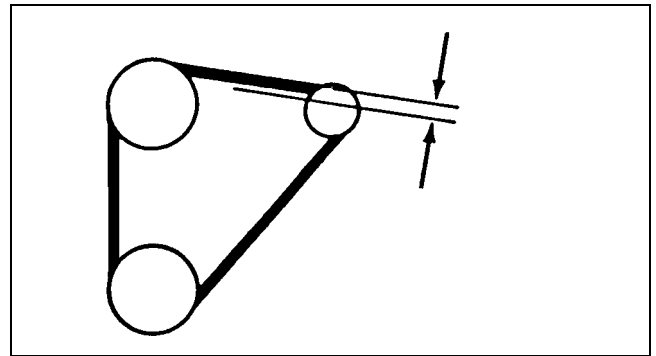

M54014

2. With applied force of **98 N (22 lb-force)** the belt deflection is **10 - 15 mm (0.4 - 0.6 in.)**.

Results:

- If deflection is not within specifications, loosen both alternator mounting cap screws/nuts. Apply force to FRONT alternator housing only (near the belt) until tension is correct. Tighten cap screws/nuts.

Radiator Bubble Test

Reason:

To determine if compression pressure is leaking from cylinder.

Equipment:

- JDG560 Adapter

Procedure:

1. With the coolant at the proper level and the radiator cap tight, run the engine for 5 minutes to bring it to operating temperature.
2. Remove the cap from the recovery tank.
3. Check for bubbles coming from the overflow hose at the bottom of the tank.

ENGINE - DIESEL TESTS AND ADJUSTMENTS

- If bubbles are present, isolate the source of the compression leak.
4. Remove the injection nozzles.
 5. Install JDG560 Adapter in the injection port of the cylinder to be tested.
 6. Move the piston to the bottom of the stroke with intake and exhaust valves closed.
 7. Connect the hose from a compressed air source to the adapter.
 8. Apply shop air pressure into the cylinder.
 9. Check for bubbles in the recovery tank or air escaping from the muffler, air cleaner or oil fill opening.
 10. Repeat for each cylinder.

Results:

- If bubbles are present in the recovery tank, check for cracks in the cylinder head and block. Check for a damaged head gasket.
- If air escapes from the muffler, check for a worn exhaust valve.
- If air escapes from the air cleaner, check for a worn intake valve.
- If air escapes from the engine oil fill, check for worn piston rings.

Cooling System Pressure Test

Reason:

Inspect the cooling system for leaks.

Equipment:

- D05104ST Cooling System Pressure Pump
- JDG692 Radiator Pressure Test Kit (Adapters)

Procedure:

1. Remove the cap and attach the pressure pump to radiator.
2. Apply pressure according to specifications, not to exceed **97 kPa (14 psi)**.
3. Check for leaks throughout the cooling system. After 15 seconds the minimum pressure is **88 kPa (12.8 psi)**.

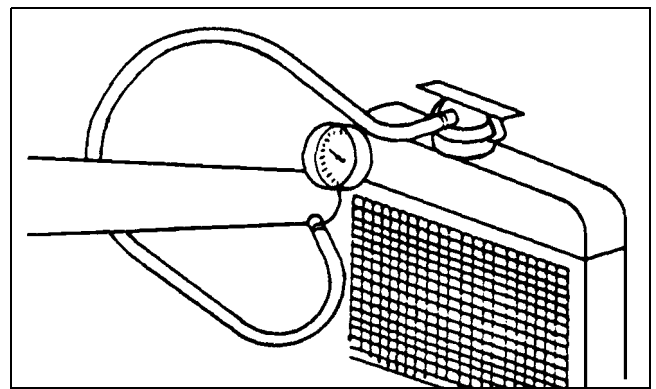

T6333AW

Results:

- Pressure should hold to **88 ± 15 kPa (12.8 ± 2.2 psi)**. If pressure decreases, check for leaks. Repair leaks or replace parts as necessary.
- If the pressure test still indicates leakage after all external leaks have been stopped, a defective head gasket, cracked block, or cylinder head may be the cause. See "Radiator Bubble Test" on page 53.

Radiator Pressure Cap Test

Reason:

Test the radiator cap for operating in the correct pressure range.

Equipment:

- D05104ST Cooling System Pressure Pump
- JDG692 Radiator Pressure Test Kit (Adapters)

Procedure:

1. Install the radiator cap (A) on the pressure pump.
2. Apply pressure. Pressure valve in the cap should open at **88 kPa (12.8 psi)**.

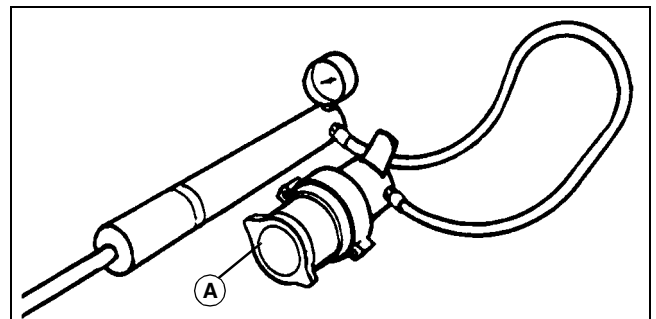

T6333AX

Results:

- If the cap leaks, retighten and test again. Replace the cap if pressure is not within specification.

ENGINE - DIESEL TESTS AND ADJUSTMENTS

Engine Oil Pressure Test

Reason:

To determine if the engine bearings or the lubrication system components are worn.

Equipment:

- JT03017 Hose Assembly
- JT05577 Pressure Gauge (100 psi)
- JT03349 Connector

Procedure:

1. Remove the oil pressure sender.

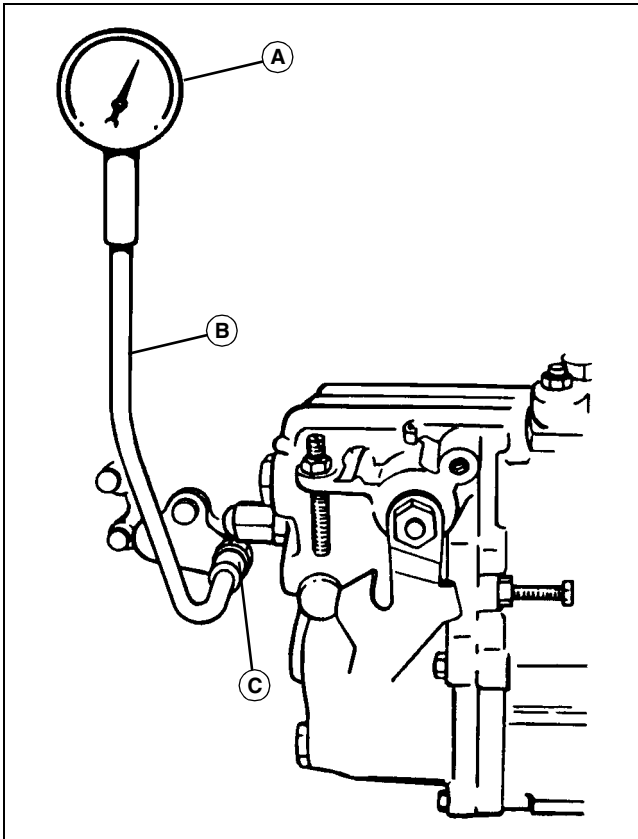

T6471FB

2. Install JT03349 Connector (C).
3. Connect JT03017 Hose Assembly (B) and JT05577 Pressure Gauge (A).

IMPORTANT: Avoid damage! DO NOT run the engine if there is insufficient oil pressure!

4. Start the engine. If the pressure reading is below **0.06 MPa (8.7 psi)** at slow idle rpm, STOP THE ENGINE.
5. If the oil pressure is at least **0.06 MPa (8.7 psi)** run the engine approximately five minutes to heat the oil. Check the oil pressure at **2700 rpm**.

Specification:

Oil Pressure

4210 **0.29 ± 0.05 MPa (42 ± 7.2 psi)**

4310, 4410 **0.34 ± 0.05 MPa (49 ± 7.2 psi)**

Results:

- If the oil pressure is not within specifications, inspect the oil pump.
- If the oil pump is within specifications, the engine may have parts worn beyond specifications. See “Engine Troubleshooting” on page 36.

Fuel Transfer Pump Tests

Pressure Test

Reason:

To determine supply pump operating pressure.

Equipment:

- JDG356 Fuel Pump Pressure Test Kit

Procedure:

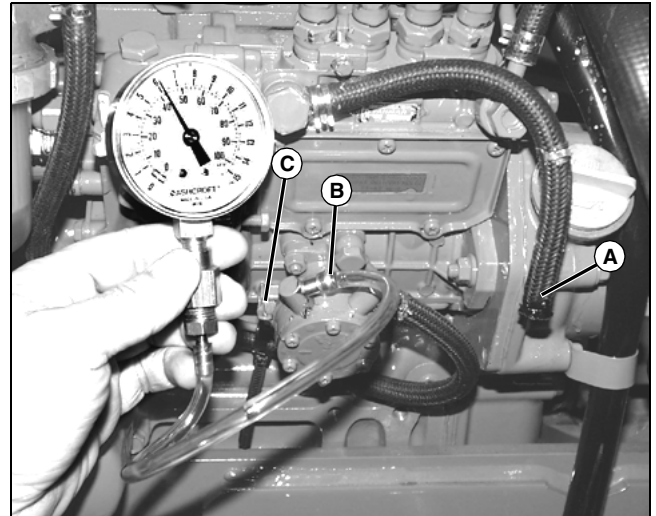

MX1155

1. Disconnect the transfer pump to injector pump hose (A).
2. Install the hose and gauge to outlet side of transfer pump (B).
3. Crank or start engine, or operate transfer pump with hand primer lever (C) if equipped.
4. Record fuel pressure reading on gauge.

Results:

- If the pressure is below specification, replace the fuel supply pump.

ENGINE - DIESEL TESTS AND ADJUSTMENTS

Specification:

Fuel Pressure 29 kPa (4.2 psi) min.)

Flow Test

Conditions:

Fuel Temperature For Tests. 15 - 25°C (59 - 77°F)

Procedure:

1. Disconnect fuel shutoff solenoid wire.

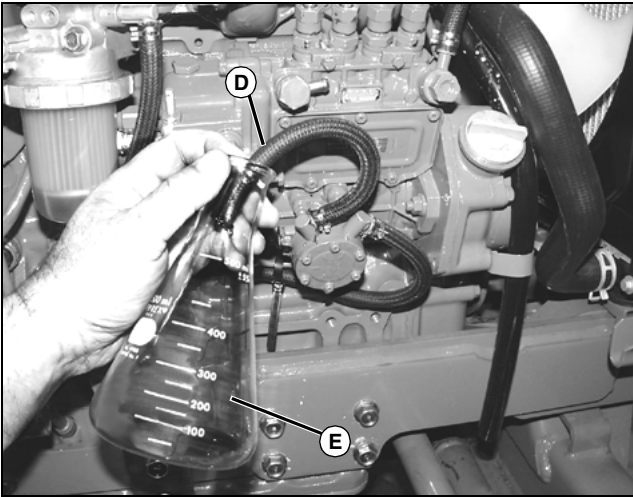

MX1156

2. Disconnect fuel transfer pump outlet hose from fuel injection pump (D). Collect fuel in graduated container (E) as key switch is turned to "START" position to crank engine 15 seconds. Compare fuel amount to specification.

Specification:

Fuel Flow 15 sec. 50 mL (1.5 oz min.)

Fuel System Leakage Test

Reason:

Tests the fuel system plumbing for external leakage. This test also determines if air is entering the fuel system at connections, allowing fuel to siphon back to tank.

Procedure:

1. Disconnect the fuel supply line and return line at the fuel tank.
2. Place the fuel return line into a suitable container to catch drained fuel.



CAUTION: Avoid Injury! DO NOT apply more than 103 kPa (15 psi) air pressure to the fuel system. Damage to the injection pump or personal injury may result.

3. Apply **34 - 69 kPa (5 - 10 psi)** air pressure to fuel supply hose until all fuel is drained from the system.
4. Plug the end of the fuel return hose.
5. Apply **34 - 69 kPa (5 - 10 psi)** air pressure to the fuel system at the fuel supply line. **DO NOT** exceed a maximum pressure of **103 kPa (15 psi)**.
6. Apply liquid soap and water solution to all joints and connections in the fuel system, and inspect for leaks.

Results:

- Find leaks and repair or replace parts as necessary.

Bleed Fuel System

All engines are equipped with an automatic air venting system which makes the fuel system self-bleeding.

- Assure that all fuel line connections are securely tightened.
- Add fuel to the fuel tank.
- Crank the engine to allow fuel system to bleed itself.

ENGINE - DIESEL REPAIR

Repair

Engine Removal

1. Split the machine between the flywheel housing and the tunnel. See "Machine Splitting - Front" in the appropriate power train section.
2. Remove the hood.
3. Drain the coolant from the radiator and the engine block.
4. Drain the lubrication oil, and the fuel tank.
5. Remove the battery.
6. Remove the muffler.
7. Remove the coolant overflow tank.
8. Remove the air cleaner.
9. Remove the radiator coolant hoses.
10. Disconnect the hydraulic cooler lines.
11. Remove the radiator.
12. Remove the dipstick and tube.
13. Remove the starting motor wires.
14. Disconnect the intake manifold air heater.

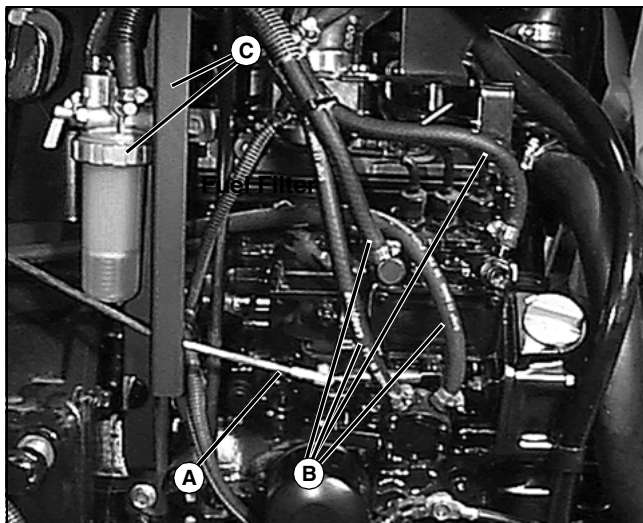

M94772a

15. Disconnect the throttle rod (A).
16. Label and disconnect the fuel hoses (B).
17. Remove the fuel filter shield and fuel filter (C) from the engine.
18. Disconnect the fuel solenoid.
19. Disconnect the oil pressure sending unit.
20. Remove the hood support.
21. Disconnect the fuel tank sending unit.
22. Remove the flasher, if equipped.

23. Remove the steering wheel.
24. Remove the control panel.
25. Remove the left side shield.
26. Disconnect the wiring harness, oil pressure switch, and ground wires from the engine.
27. Remove the return springs, and the left side brake pedals.
28. Remove the bushing from the brake pedal shaft.
29. Remove the return spring, cotter pin, and washer from the brake pedal shaft, and remove the right side pedal with the pedal shaft from the machine.
30. Label and remove the fuel hoses from the fuel tank.
31. Loosen the dash board support, and pull the support toward the rear of the machine.
32. Lift out the fuel tank.
33. Remove the pedal support.
34. Install lifting brackets to the cylinder head.
35. Install the engine hoist to the lift brackets. Lift the engine slightly and safely support the machine frame.

NOTE: Use more than one support to support the frame. The frame will pivot on the front axle, and could slip off of a single support.

36. Disconnect the front wiring harness.

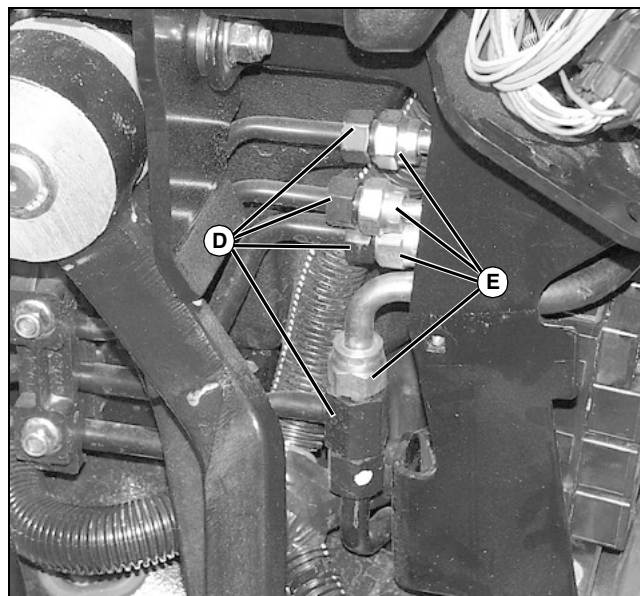

MX9840

37. Label the hydraulic lines (D) and hoses from the steering control unit (E) and disconnect.
38. Remove the flywheel from the engine. See "Flywheel and Coupling" on page 78.
39. Remove the flywheel housing from the engine.

ENGINE - DIESEL REPAIR

NOTE: The flywheel housing is heavy. Use an assistant, and proper tools to remove and lift the flywheel housing.

The starting motor may be removed with the flywheel housing.

40. With the frame supported, and the engine attached to the engine hoist, remove the cap screws that fasten the engine oil pan to the frame (eight on each side). Lift and slide the engine out of the back of the frame. Place the engine on a bench or suitable engine stand.

NOTE: The engine is heavy and is a tight fit to the frame. Use an engine hoist and an assistant to remove the engine from the frame.

Rocker Cover Removal and Installation

Removing:

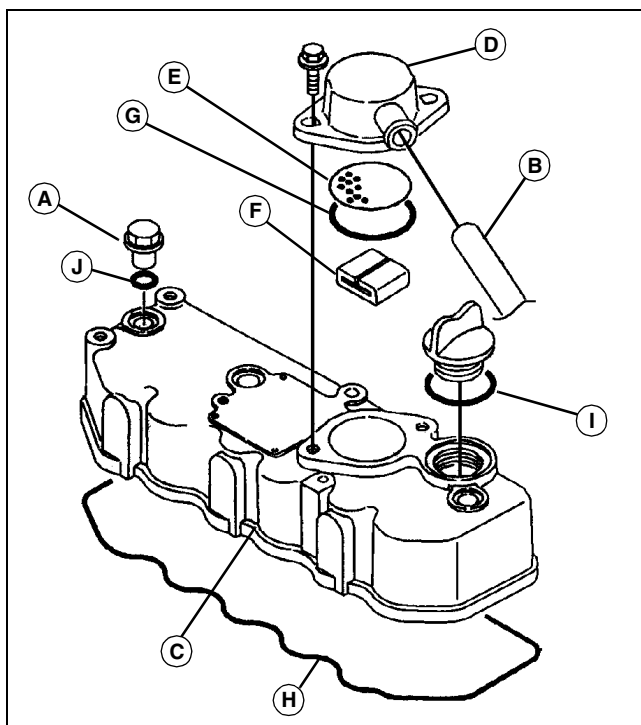

M91950

1. Remove the air cleaner and muffler.
2. Remove three rocker cover nuts (A).
3. Remove the breather hose (B).
4. Remove the rocker cover (C) from the cylinder head.
5. Remove the breather cap (D), plate (E), and baffle (F).
6. Wash the baffle in a safe solvent and blow dry with air. Replace the baffle if it comes apart or is deteriorated.

Installing:

1. Install the baffle.

2. Install the breather plate and a new O-Ring (G) before replacing breather cover.

3. Inspect the rocker cover gasket (H), and O-rings (I) and (J) for before reinstalling the rocker arm cover. Replace if damaged.

4. Clean the cylinder head surface and install the rocker cover to the cylinder head. Install the rocker cover nuts.

Rocker Arm Assembly

Removal/Installation and Disassembly/Assembly:

1. Remove the rocker cover. See "Rocker Cover Removal and Installation" on page 58.

2. Remove the rocker arm end support and rocker arm center support mounting cap screws.

3. Lift the rocker arm assembly from the cylinder head and set the assembly on a bench.

NOTE: If the rocker arm shaft assembly is to be disassembled, replace components in same location on the rocker arm shaft they were removed from.

4. Note the positions of the rocker arm assembly components. Slide the components off the rocker arm shaft.

5. Lift the push rods from the cylinder head and note the order of removal for reassembly.

6. Inspect the rocker arm components and push rods.

7. Reinstall the push rods to their original location in the cylinder head, with the ball shaped end down in head.

8. Lubricate all parts with clean oil during assembly.

9. Assemble the rocker arm assembly components in the reverse order of removal.

10. Place the rocker arm assembly on the cylinder head.

- Align the rocker arms with the valves and push rods.
- Align the rocker arm end supports and center supports with the corresponding holes in the head.

11. Install the rocker arm support cap screws. Tighten the cap screws to **26 N•m (19 lb-ft)**.

12. Adjust the valve clearance.

ENGINE - DIESEL REPAIR

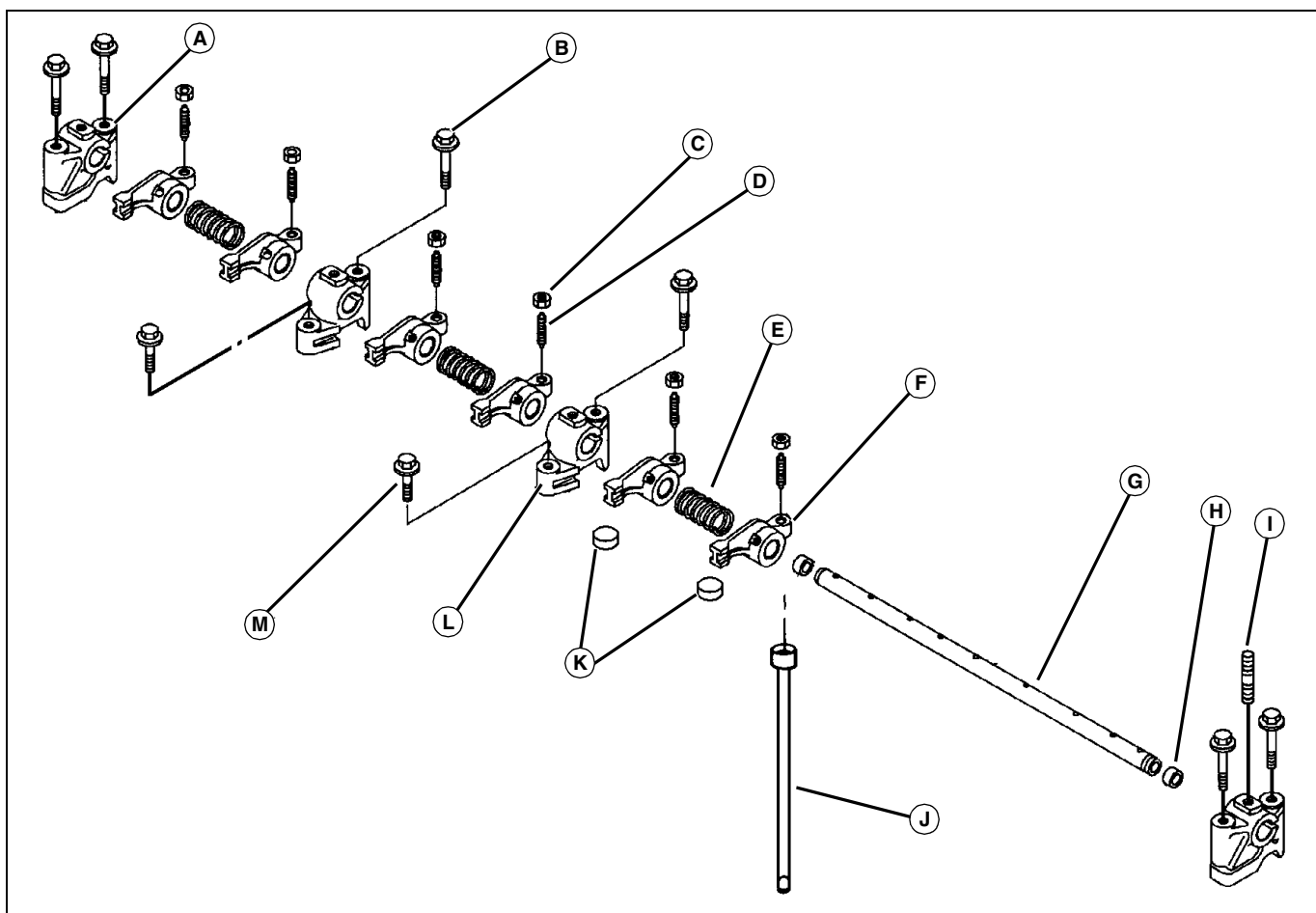

M91949B

- A - Shaft End Support (2)
- B - Cap Screw, M8 x 50 (6)
- C - Jam Nut (6)
- D - Adjuster Screw (6)
- E - Spring (3)
- F - Rocker Arm
- G - Rocker Arm Shaft
- H - Plug (2)
- I - Stud
- J - Push Rod (6)
- K - Valve Caps (6)
- L - Center Support (2)
- M - Cap Screw, M8 x 25

Inspection:



M35262

1. Measure the outer diameter of the rocker arm shaft.
 - Rocker arm shaft OD is **15.97 - 15.98 mm (0.628 - 0.629 in.)**.
 - Replace the rocker arm shaft if the OD is less than **15.95 mm (0.628 in.)**.

ENGINE - DIESEL REPAIR

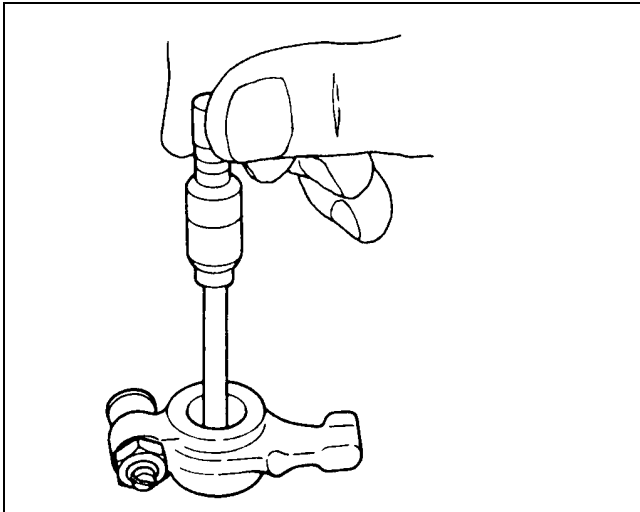

M82022A

2. Measure the inner diameters of the rocker arms and supports.
 - Standard ID is **16.00 - 16.02 mm (0.630 - 0.631 in.)**.
 - Replace the rocker arms or supports if the ID is more than **16.09 mm (0.633 in.)**.
3. Measure the rocker arm shaft to rocker arm bushing oil clearance. Oil clearance is the difference between the OD of the rocker arm shaft and the ID of the rocker arms.
 - Standard oil clearance is **0.02 - 0.05 mm (0.001 - 0.002 in.)**.
 - If the clearance exceeds **0.14 mm (0.006 in.)** replace the rocker arm shaft and rocker arms.

Measure bending of push rod:

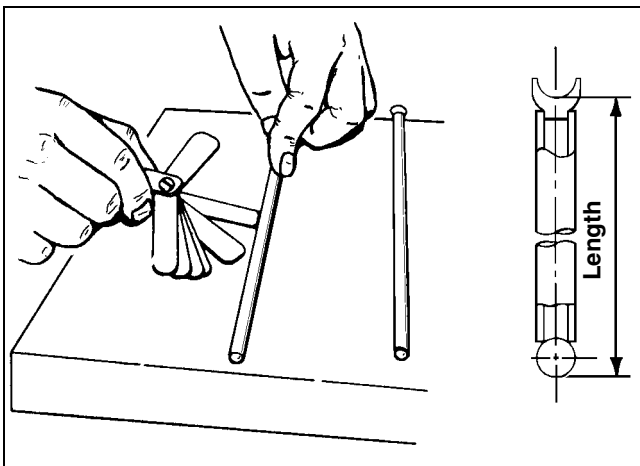

M82023A

1. Place the push rod on a flat surface. Use a feeler gauge to measure any gaps between the push rod and flat surface.
 - Replace any push rod with more than **(0.03 mm (0.001 in.)** bend.

Inspect Rocker Arm Contact Surfaces:

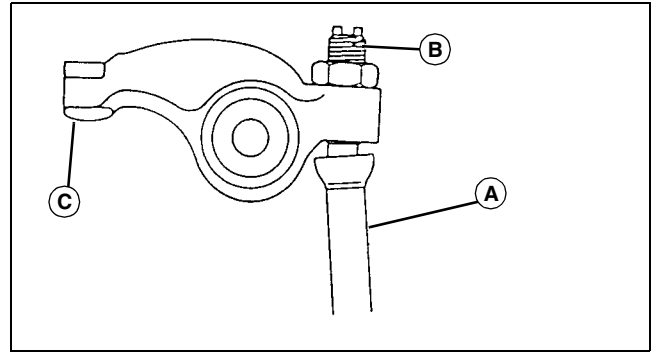

M76398

1. Check the surface of the adjusting screw that contacts the push rod (A) for wear. Replace the adjusting screw (B) if it is worn or damaged.
2. Check the surface (C) of the rocker arm that comes in contact with the valve cap for wear. Replace rocker arm if necessary.
3. Check the socket portion of the push rod where the valve clearance adjusting screw contacts the push rod. Replace the push rod if it is worn or damaged.

Cylinder Head and Valves Removal and Installation

Removing:

1. Remove the rocker arm cover. See "Rocker Cover Removal and Installation" on page 58.
2. Remove the rocker arm assembly, push rods and valve caps. See "Rocker Arm Assembly" on page 58.
3. Remove the exhaust and intake manifolds. See "Exhaust Manifold" on page 65.
4. Remove the water pump. See "Thermostat and Water Pump" on page 86.
5. Remove the fuel injection nozzles. See "Fuel Injection Nozzles" on page 92.



Suggest:

If the above button click is invalid.

Please download this document

first, and then click the above link

to download the complete manual.

Thank you so much for reading

ENGINE - DIESEL REPAIR

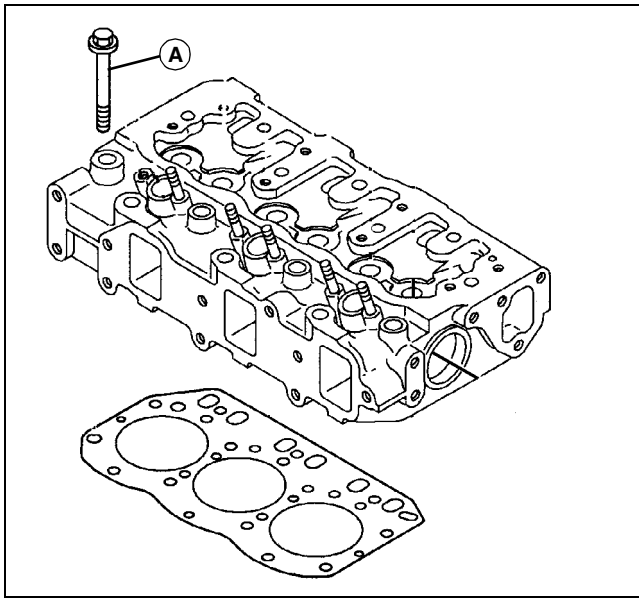

M91949A

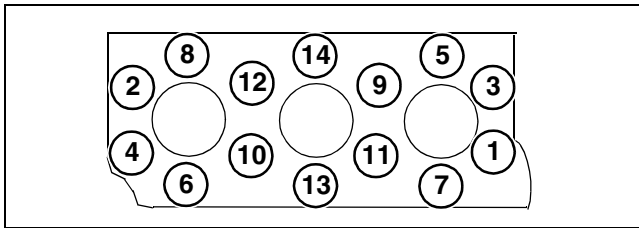

MIF

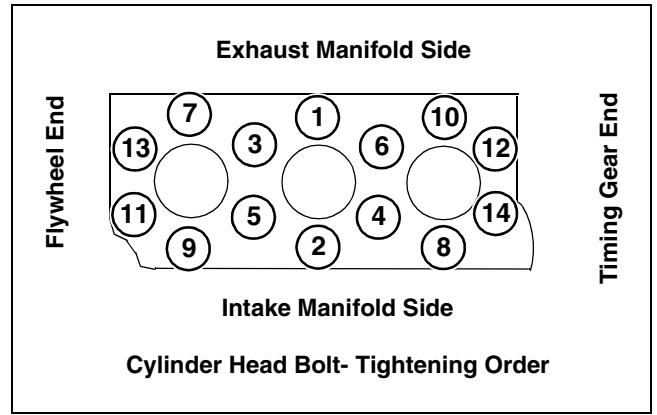

MIF

6. Remove the cylinder head bolts (A) in the order shown.
7. Remove the cylinder head from the engine block.
8. Disassemble and inspect the cylinder head and valves. See "Cylinder Head and Valves Disassembly and Assembly" on page 61.

Installing:

1. Reassemble the cylinder head and valves. See "Cylinder Head and Valves Disassembly and Assembly" on page 61.

IMPORTANT: Avoid damage! The oil passage in the gasket must be located over the oil passage in cylinder block.

2. Place a new cylinder head gasket on the engine block. Dowels in the engine block will assist in aligning the gasket.
3. Place the cylinder head on the engine block. Dowels in the engine block will again assist in alignment.

4. Dip the head bolts in clean engine oil, install and tighten in the sequence shown, in three stages of gradually-increasing torque. Tighten the head bolts to specification.

Specification:

Cylinder Head Bolt Torque:

4210 Initial Torque	35 N•m (26 lb-ft)
Second Step Torque	48 N•m (36 lb-ft)
Final Torque	69 N•m (51 lb-ft)
4310-4410 Initial Torque	44 N•m (33 lb-ft)
Second Step Torque	62 N•m (45 lb-ft)
Final Torque	88 N•m (65 lb-ft)

IMPORTANT: Avoid damage! Cylinder head bolts must be checked for proper torque after 50 hours of engine operation.

5. Install the fuel injection nozzles. See "Fuel Injection Nozzles" on page 92.
6. Install the water pump. See "Thermostat and Water Pump" on page 86.
7. Install the exhaust and intake manifolds. See "Exhaust Manifold" on page 65, and "Intake Manifold" on page 65.
8. Install the rocker arm assembly, push rods and valve caps.

Cylinder Head and Valves Disassembly and Assembly

Removing:

1. Remove the valve caps from the valves. The valve caps should be installed on the valves they were removed from.
2. Compress the valve spring using a valve spring compressor and remove the collet halves, retainer, valve spring and valve stem seal for each valve.
3. The intake and exhaust valve guides are press fit.

<https://www.ebooklibonline.com>

Hello dear friend!

Thank you very much for reading.

Enter the link into your browser.

The full manual is available for immediate download.

<https://www.ebooklibonline.com>