

**JOHN DEERE**  
**WORLDWIDE COMMERCIAL & CONSUMER**  
**EQUIPMENT DIVISION**

---

**Compact Utility Tractor**  
**4010**

OMLVU13343 D2

**OPERATOR'S MANUAL**



**JOHN DEERE**

European Version  
Litho in U.S.A.

# INTRODUCTION

---

## Thank You for Purchasing a John Deere Product

We appreciate having you as a customer and wish you many years of safe and satisfied use of your machine.

## Using Your Operator's Manual

This manual is an important part of your machine and should remain with the machine when you sell it.

Reading your operator's manual will help you and others avoid personal injury or damage to the machine. Information given in this manual will provide the operator with the safest and most effective use of the machine. Knowing how to operate this machine safely and correctly will allow you to train others who may operate this machine.

If you have an attachment, use the safety and operating information in the attachment operator's manual along with the machine operator's manual to operate the attachment safely and correctly.

This manual and safety signs on your machine may also be available in other languages (see your John Deere dealer to order).

Sections in your operator's manual are placed in a specific order to help you understand all the safety messages and learn the controls so you can operate this machine safely. You can also use this manual to answer any specific operating or servicing questions. A convenient index located at the end of this book will help you to find needed information quickly.

The machine shown in this manual may differ slightly from your machine, but will be similar enough to help you understand our instructions.

RIGHT-HAND and LEFT-HAND sides are determined by facing in the direction the machine will travel when going forward. When you see a broken line arrow (----->), the item referred to is hidden from view.

Before delivering this machine, your dealer performed a predelivery inspection to ensure best performance.

## Machine Use

This machine is designed solely for use in customary agricultural use, for park and amenity area maintenance and for winter work. Use in any other way is considered as contrary to the intended use.

The manufacturer accepts no liability for damage or injury resulting from this misuse, and these risks must be borne solely by the user. Compliance with and strict adherence to the conditions of operation, service and repair as specified

by the manufacturer also constitute essential elements for the intended use.

This machine should be operated, serviced and repaired only by persons familiar with all its particular characteristics and acquainted with the relevant safety rules (accident prevention). The accident prevention regulations, all other generally recognized regulations on safety and occupational medicine and the road traffic regulations must be observed at all times.

Setting fuel delivery beyond published factory specifications or otherwise overpowering will result in loss of warranty protection for this machine.

Any arbitrary modifications carried out on this machine will relieve the manufacturer of all liability for any resulting damage or injury.

## Special Messages

Your manual contains special messages to bring attention to potential safety concerns, machine damage as well as helpful operating and servicing information. Please read all the information carefully to avoid injury and machine damage.



**CAUTION: Avoid injury! This symbol and text highlight potential hazards or death to the operator or bystanders that may occur if the hazards or procedures are ignored.**

**IMPORTANT: Avoid damage! This text is used to tell the operator of actions or conditions that might result in damage to the machine.**

**NOTE: General information is given throughout the manual that may help the operator in the operation or service of the machine.**

# PRODUCT IDENTIFICATION

## Record Identification Numbers

### Compact Utility Tractor with a Hydrostatic Transmission

4010 PIN (110001- )

If you need to contact an Authorized Service Center for information on servicing, always provide the product model and serial number.

You will need to locate the model and serial number for the machine and for the engine of your machine and record the information in the spaces provided below.

DATE OF PURCHASE:

\_\_\_\_\_

DEALER NAME:

\_\_\_\_\_

DEALER PHONE:

\_\_\_\_\_

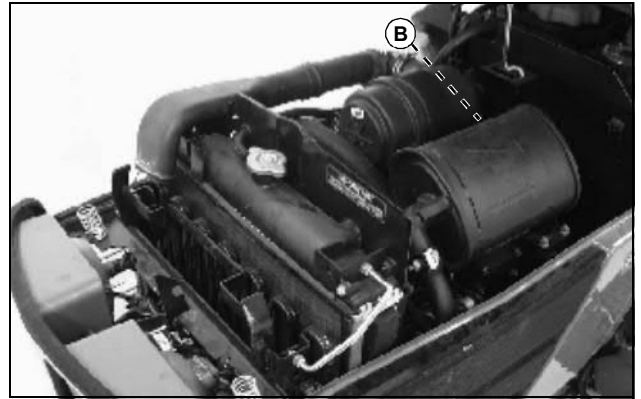

MX15576

ENGINE SERIAL NUMBER (B):

\_\_\_\_\_

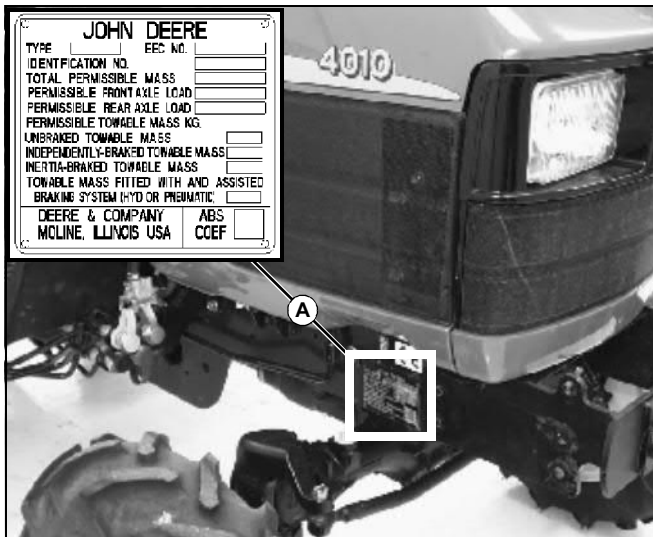

MX15985

PRODUCT IDENTIFICATION NUMBER (A):

\_\_\_\_\_

**<https://www.ebooklibonline.com>**

Hello dear friend!

Thank you very much for reading.

Enter the link into your browser.

The full manual is available for immediate download.

**<https://www.ebooklibonline.com>**

# TABLE OF CONTENTS

---

Safety .....	1
Operating .....	8
Replacement Parts .....	29
Service Intervals .....	30
Service Lubrication .....	31
Service Engine .....	34
Service Transmission .....	45
Service Electrical .....	49
Service Miscellaneous .....	55
Troubleshooting .....	58
Storage .....	61
Assembly .....	62
Specifications .....	63
Index .....	68

All information, illustrations and specifications in this manual are based on the latest information at the time of publication. The right is reserved to make changes at any time without notice.

COPYRIGHT© 2002  
Deere & Co.  
John Deere Worldwide Commercial and  
Consumer Equipment Division  
All rights reserved  
Previous Editions  
COPYRIGHT©

OMLVU13343 D2 - English

# SAFETY

## Pictorial Safety Signs



At several important places on this machine safety signs are affixed intended to signify potential danger. The hazard is identified by a pictorial in a warning triangle. An adjacent pictorial provides information how to avoid personal injury. These safety signs, their placement on the machine and a brief explanatory text are shown in this Safety Signs section.

## CAUTION



MX15988, M805494

Danger of injury at the side of seat backrest and in area behind seat. Parts of the body may be crushed or get entangled.

## WARNING

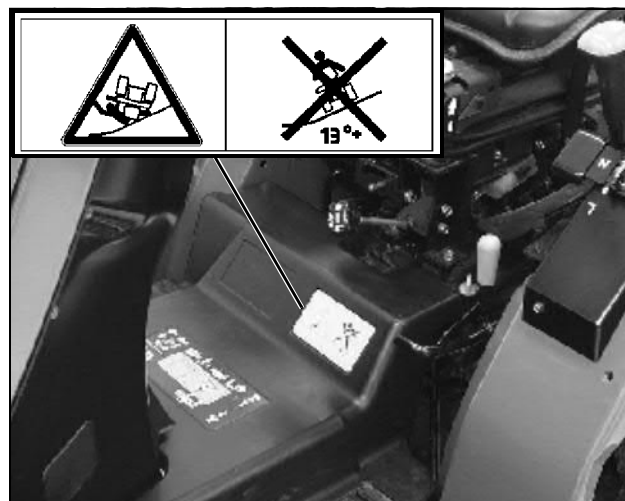

MX15986, M606451

Do not drive where tractor could slip or tip. Do not drive on a slope with more than a 13° incline.

## CAUTION



MX15987, M63037a

1. Read operator's manual before operating this tractor.
2. Keep all shields in place.
3. Hitch towed loads only to drawbar to avoid rearward upset.
4. Make certain everyone is clear of machine before starting engine or operation.
5. Keep all riders off tractor and equipment.
6. Keep hands, feet and clothing away from power-driven parts.

# SAFETY

7. Use seat belt. Extend belt completely from any wind-up device before adjusting to fit.
8. Reduce speed when turning or applying individual brakes or operating around hazards, on rough ground or steep slopes.
9. Couple brake pedals together for road travel and locking the park brake.
10. Use flashing warning lights on highway unless prohibited by law.
11. Stop engine, lower implement to ground, shift to N neutral and set park brake securely before dismounting.
12. Wait for all movement to stop before servicing machinery.
13. Remove key if leaving tractor unattended.

## CAUTION: HOT SURFACE

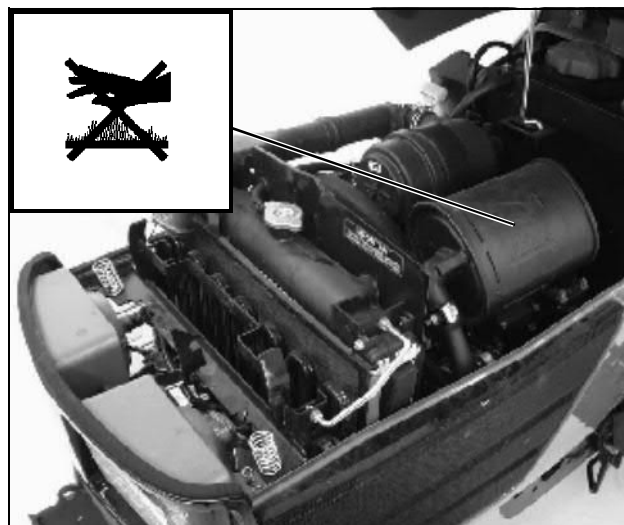

MX15576, M88248

**Picture Note: No-text warning molded into muffler.**

Do not touch engine muffler, it may be very hot.

## DANGER/POISON



MX15978, M88249

**Picture Note: Front grille removed for photo clarity.**

SHIELD EYES: EXPLOSIVE GASES CAN CAUSE BLINDNESS OR INJURY.

NO SPARKS, FLAMES, SMOKING.

SULFURIC ACID CAN CAUSE BLINDNESS OR SEVERE BURNS.

FLUSH EYES IMMEDIATELY WITH WATER. GET MEDICAL ATTENTION FAST.

KEEP OUT OF REACH OF CHILDREN. DO NOT TIP. DO NOT OPEN BATTERY.

## DRAWBAR EEC LABEL



MX15989

# SAFETY

## WAGON HITCH EEC INFORMATION

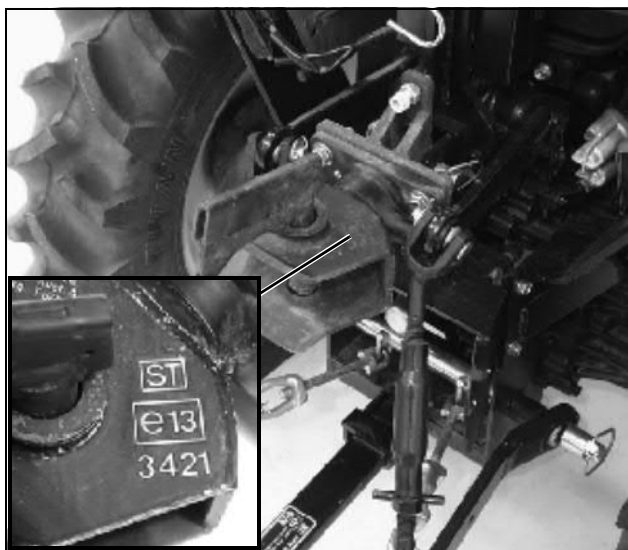

MX15990, M72571

**Picture Note:** Information stamped into top of hitch

## ROLLOVER PROTECTION CERTIFICATION PLATE

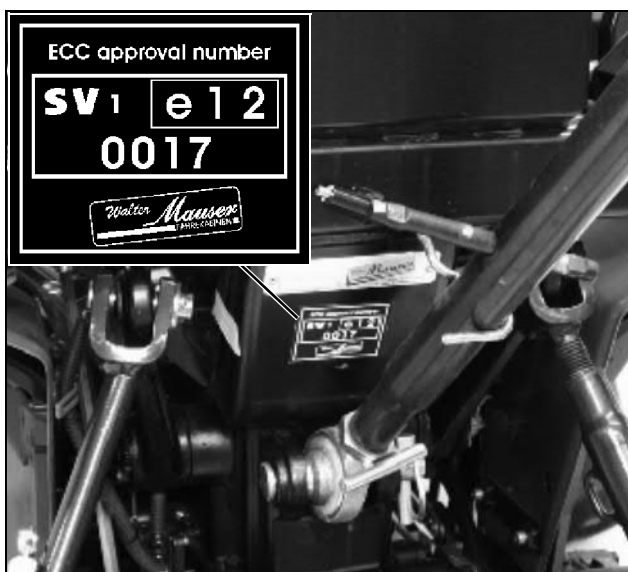

MX15945

## Operating Safely

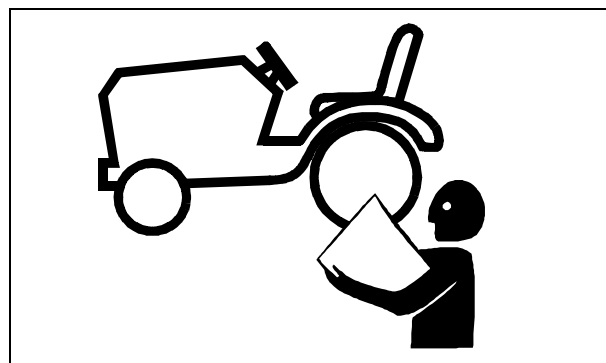

- Inspect machine before you operate. Be sure hardware is tight. Repair or replace damaged, badly worn, or missing parts. Be sure guards and shields are in good condition and fastened in place. Make any necessary adjustments before you operate.
- Be sure all drives are in neutral and parking brake is locked before starting engine. Only start engine from the operator's position.
- Check before each use that operator presence controls are functioning correctly. Test safety systems. Do not operate unless they are functioning correctly.
- Do not change the engine governor setting or overspeed the engine.
- Check brake action before you operate. Adjust or service brakes as necessary.
- Stop machine if anyone enters the area.
- If you hit an object, stop and inspect the machine. Make repairs before you operate. Keep machine and attachments properly maintained and in good working order.
- Do not leave machine unattended when it is running.
- Only operate during daylight or with good artificial light.
- Slow down and be careful of traffic when operating near or crossing roadways. Use care when approaching blind corners, shrubs, trees, or other objects that may obscure vision.
- Be aware of the mower discharge direction and make sure that no one is in the path of the discharge direction.

## Parking Safely

1. Stop machine on a level surface, not on a slope.
2. Stop attachments.
3. Lower attachments to the ground.
4. Lock park brake.

# SAFETY

5. Stop engine.
6. Remove key.
7. Wait for engine and all moving parts to stop before you leave the operator's station.
8. Close fuel shut-off valve, if your machine is equipped.

## Avoid Tipping

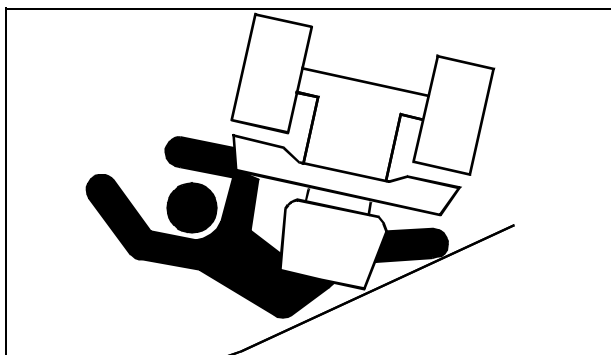

- Slopes are a major factor related to loss-of-control and tip-over accidents, which can result in severe injury or death.
- Do not drive where machine could slip or tip.
- Stay alert for holes and other hidden hazards in the terrain.
- Keep away from drop-offs, ditches, and embankments.
- Slow down before you make a sharp turn or operate on a slope. On gear models, choose a low gear so that shifting and stopping will not be necessary while on the slope.
- Limit loads to those you can safely control. Use only approved hitches when pulling loads or using heavy equipment. Use counterweights or wheel weights as required in this manual or your attachment manual.
- Drive machine very slowly and avoid quick stops when attachment is removed.
- Drive up and down a hill - not across. If necessary, turn slowly and in the downhill direction. Do not shift to neutral and coast downhill.
- Do not stop when going up hill or down hill. If machine stops going up hill, back down slowly.
- Operating machine when grass is wet can cause reduced traction and sliding.

## Keep Riders Off



- Only allow the operator on the machine. Keep riders off.
- Riders on the machine or attachment may be struck by foreign objects or thrown off the machine causing serious injury.
- Riders obstruct the operator's view resulting in the machine being operated in an unsafe manner.

## Checking Wheel Bolts

- A serious accident could occur causing serious injury if wheel bolts are not tight.
- Check wheel bolt tightness often during the first 100 hours of operation.
- Wheel hardware must be tightened to specified torque using the proper procedure anytime it is loosened.

## Stay Clear of Rotating Drivelines



Entanglement in rotating driveline can cause serious injury or death.

- Wear close fitting clothing.
- Stop the engine and be sure PTO driveline is stopped before getting near it.

# SAFETY

## Wear Appropriate Clothing

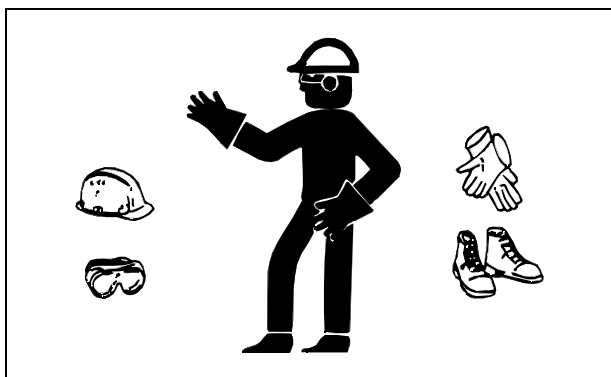

- Wear close fitting clothing and safety equipment appropriate for the job.
- Always wear safety goggles or safety glasses with side shields when operating the mower.
- Wear a suitable protective device such as earplugs. Loud noise can cause impairment or loss of hearing.
- Do not wear radio or music headphones. Safe service and operation requires your full attention.
- Long hair, loose clothing, or jewelry may get tangled in moving parts.

## Practice Safe Maintenance



- Only qualified, trained adults should service this machine.
- Understand service procedure before doing work. Keep area clean and dry.
- Never lubricate, service, or adjust machine while it is moving. Keep safety devices in place and in working condition. Keep hardware tight.
- Keep hands, feet, clothing, jewelry, and long hair away from any moving parts, to prevent them from getting caught.
- Stop machine on a level surface and lower attachments to the ground before servicing machine. Disengage all power and stop the engine. Lock park brake and remove the key. Let machine cool.
- Disconnect battery or remove spark plug wire before making any repairs.
- Before servicing machine, carefully release pressure from components with stored energy such as hydraulic components.
- Keep all nuts and bolts tightened.
- Securely support any machine elements that must be raised for service work. Lock service latches before working on machine with raised attachments.
- Use jack stands to support components when needed.
- Never run engine unless park brake is locked.
- Keep all parts in good condition and properly installed. Fix damage immediately. Replace worn or broken parts. Replace all worn or damaged safety and instruction decals.
- To prevent fires, remove any buildup of grease, oil, or debris from the machine, especially the engine compartment.
- Charge batteries in an open, well-ventilated area, away from sparks. Unplug battery charger before connecting or disconnecting from the battery. Wear protective clothing and use insulated tools.

## Driving Safely on Public Roads

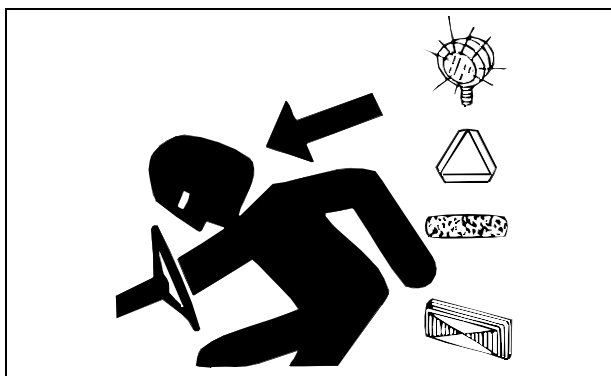

- Use safety lights and devices. Slow moving machines when driven on public roads are hard to see, especially at night.
- Whenever driving on public roads, use flashing warning lights and turn signals according to local regulations. Extra flashing warning lights may need to be installed.

# SAFETY

- Do not modify machine or safety devices. Unauthorized modifications may impair its function and safety.
- Do not wear radio or music headphones while servicing the machine. Safe service requires your full attention.

## Avoid High Pressure Fluids



- Hydraulic hoses and lines can fail due to physical damage, kinks, age, and exposure. Check hoses and lines regularly. Replace damaged hoses and lines.
- Hydraulic fluid connections can loosen due to physical damage and vibration. Check connections regularly. Tighten loose connections.
- Escaping fluid under pressure can penetrate the skin causing serious injury. Avoid the hazard by relieving pressure before disconnecting hydraulic or other lines. Tighten all connections before applying pressure.
- Search for leaks with a piece of cardboard. Protect hands and body from high pressure fluids.
- If an accident occurs, see a doctor immediately. Any fluid injected into the skin must be surgically removed within a few hours or gangrene may result. Doctors unfamiliar with this type of injury should reference a knowledgeable medical source. Such information is available from Deere & Company Medical Department in Moline, Illinois, U.S.A. Information may be obtained in the United States and Canada only by calling 1-800-822-8262.

## Prevent Fires

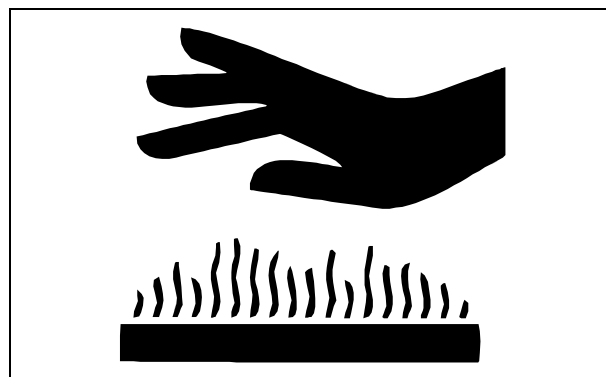

- Never remove fuel cap, or add fuel with engine running or hot. Allow engine to cool for several minutes.
- Never store equipment with fuel in the tank inside a building where fumes may reach an open flame or spark.
- Allow engine to cool before storing in any enclosure.
- To reduce fire hazard, keep engine free of grass, leaves, or excessive grease.
- Close fuel shut-off valve when storing or transporting, if machine is equipped.

## Tire Safety

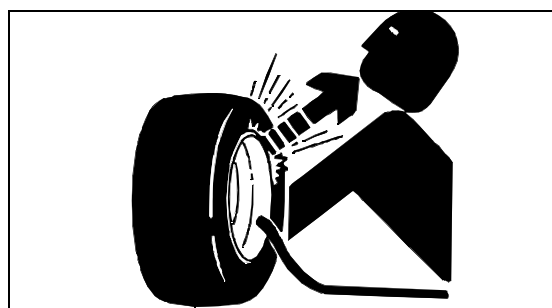

- Do not attempt to mount a tire without the proper equipment and experience to perform the job.
- Always maintain the correct tire pressure. Do not inflate the tires above the recommended pressure. Never weld or heat a wheel and tire assembly. The heat can cause an increase in air pressure resulting in a tire explosion. Welding can structurally weaken or deform the wheel.
- When inflating tires, use a clip-on chuck and extension hose long enough to allow you to stand to one side and not in front of or over the tire assembly.
- Check tires for low pressure, cuts, bubbles, damaged rims or missing lug bolts and nuts.

# SAFETY

## Handling Waste Product and Chemicals

Waste products, such as, used oil, fuel, coolant, brake fluid, and batteries, can harm the environment and people:

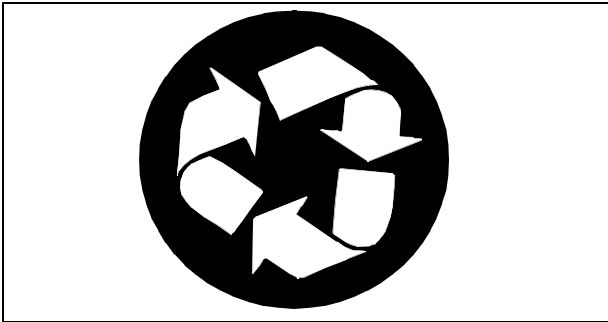

- DO NOT use beverage containers for waste fluids - someone may drink from them.
- See your local Recycling Center or John Deere dealer to learn how to recycle or get rid of waste products.

## Handling Fuel Safely

Fuel and fuel vapors are highly flammable and explosive:



- Do not refuel machine while you smoke, when machine is near an open flame or sparks, or when engine is running. Stop engine and allow to cool before filling.
- Never remove the fuel cap or add fuel with the engine running.
- Never fill fuel tank or drain fuel from a machine in an enclosed area. Fill fuel tank outdoors.
- Prevent fires. Clean up spilled fuel immediately.
- Do not store machine with fuel in tank in a building where fumes may reach an open flame or spark.
- Prevent fire and explosion caused by static electric discharge. Use only non-metal, portable fuel containers approved by the Underwriter's Laboratory (U.L.) or the American Society for Testing & Materials (ASTM). If using a funnel, make sure it is plastic and has no screen or filter.



- Static electric discharge can ignite gasoline vapors in an ungrounded fuel container. Remove the fuel container from the bed of a vehicle or the trunk of a car and place on the ground away from the vehicle before filling. Keep nozzle in contact with container opening while filling.
- When practical, remove equipment from trailers or truck beds and refuel them on the ground. If this is not possible, use a portable, plastic fuel container to refuel equipment on a truck bed or trailer.
- For gasoline engines, do not use gas with methanol. Methanol is harmful to your health and to the environment.

# OPERATING

## Daily Operating Checklist

- Test safety systems.
- Check tire pressure.
- Check fuel level.
- Check engine oil level.
- Check transmission oil level.
- Check coolant level on liquid cooled engine.
- Remove grass and debris from machine.
- Clean air intake screen.
- Check area below machine for leaks.
- Check wheel bolt torque.

- F - Park Brake Lock
- G - Position/Taillight Switch
- H - Cruise Control Lever
- I - Hazard/Warning Light Switch
- J - Horn Switch
- K - Power Take Off (PTO) Switch
- L - Ignition Key Switch
- M - Engine Speed Hand Throttle
- N - Forward Travel Pedal
- O - Reverse Travel Pedal
- P - Selective Control Valve (SCV) Lever
- Q - Rockshaft Control Lever
- R - Power Take Off (PTO) Control Lever
- S - Neutral Lockout Lever
- T - Transmission Range Shift Lever

## Avoid Damage to Plastic and Painted Surfaces

- Do not wipe plastic parts unless rinsed first.
- Insect repellent spray may damage plastic and painted surfaces. Do not spray insect repellent near machine.
- Be careful not to spill fuel on machine. Fuel may damage surface. Wipe up spilled fuel immediately.

## Operator Station

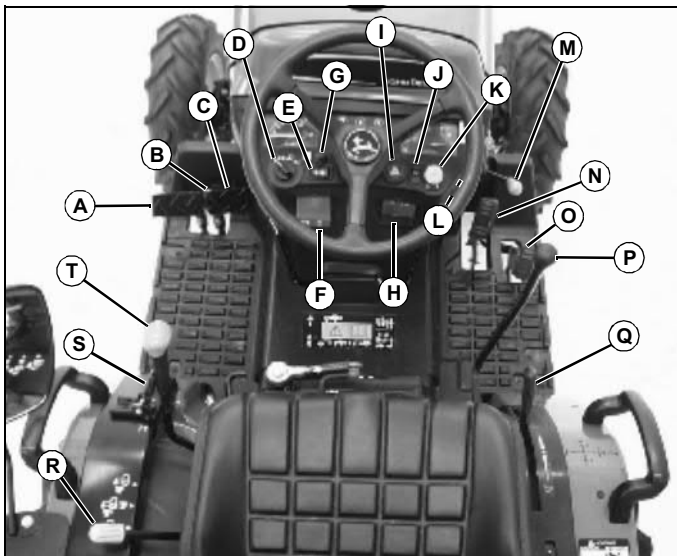

- A - Left Turn Brake Pedal
- B - Transport/Park Brake Lock Lever
- C - Right Turn Brake Pedal
- D - Operating Light Control Switch
- E - Turn Signal Switch

## Floor Panel Controls

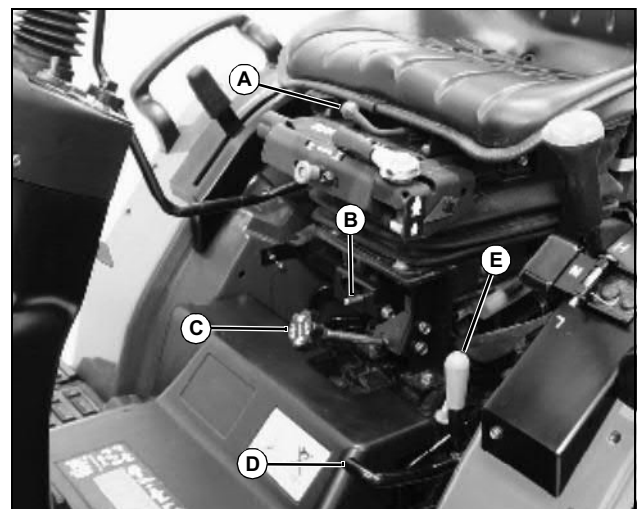

- A - Operator Seat Adjustment Lever
- B - Selective Control Valve (SCV) Lock
- C - Rockshaft Rate-of Drop Control Knob
- D - Differential Lock Pedal
- E - Mechanical Front Wheel Drive (MFWD) Control Lever

## Adjusting Operator Seat

**NOTE:** Before starting engine to operate machine, adjust operator seat position, height and suspension.

### Adjusting Seat Position

1. Sit on operator seat.

# OPERATING

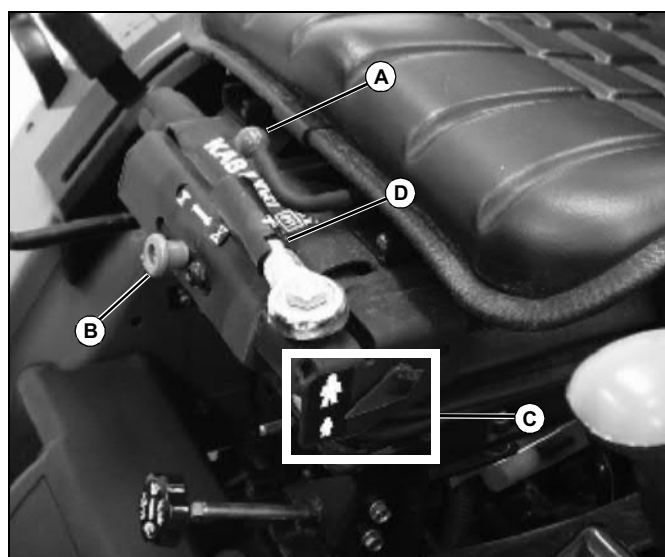

MX15992

2. Rotate seat lever (A) to the left.
3. Slide seat forward or rearward to desired position.
4. Release lever to lock seat in position. Make sure all controls can be easily accessed.

## Adjusting Seat Height

1. Move knob (B) right to lower operator seat.
2. Move knob (B) left to raise operator seat.

## Adjusting Seat Suspension

Adjust seat suspension to accommodate the weight of the operator. Refer to operator size label and indicator arrow (C) on the left side of seat suspension frame when making an adjustment.

### For a firmer ride:

1. Rotate handle (D) to the "+" position.
2. Move handle with ratcheting motion to increase seat spring tension.

### For a softer ride:

1. Rotate handle (D) to the "-" position.
2. Move handle with ratcheting motion to decrease seat spring tension.

## Testing Safety Systems

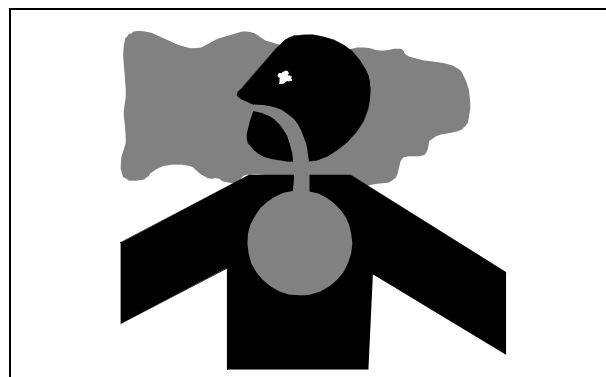

**CAUTION: Avoid injury! Engine exhaust fumes contain carbon monoxide and can cause serious illness or death.**

**Move the vehicle to an outside area before running the engine.**

**Do not run an engine in an enclosed area without adequate ventilation.**

- **Connect a pipe extension to the engine exhaust pipe to direct the exhaust fumes out of the area.**
- **Allow fresh outside air into the work area to clear the exhaust fumes out.**

Use the following checkout procedure to check for normal operation of machine.

If there is a malfunction during one of these procedures, Do not operate machine. **See your John Deere dealer for service.**

Perform these tests in a clear open area. Keep bystanders away.

## Testing the Neutral Start Switch

1. Sit on operator's seat.
2. Push PTO knob down to the disengaged/off position.
3. Move the transmission range shift lever to the H (high) or L (low) position.
4. Depress completely forward or reverse hydrostatic drive pedal.
5. Turn key switch to START position.
  - Engine must not crank.
6. Turn key switch to the OFF position.

# OPERATING

## Testing the Power-Take-Off (PTO) Switch

1. Sit on operator's seat.
2. Place the range shift lever in the N (neutral) position.
3. Pull PTO knob up to the engaged/on position.
4. Turn key to the START position.
  - Engine must not crank.
5. Push PTO knob down to the disengaged/off position.
6. Turn key switch to the OFF position.

## Testing the Seat Switch/PTO Interface

1. Sit on operator's seat.
2. Return hydrostatic travel pedals to neutral position and lock the park brake.
3. Start machine engine.
4. Pull PTO knob up to the engaged/on position.
5. Raise up from operator's seat. Do not dismount machine.
6. Engine shut-off solenoid must de-energize in 1/2 second, causing the engine and all attachments to stop.

## Testing the Seat Switch

1. Sit on operator's seat.
2. Return hydrostatic travel pedals to neutral position and lock the park brake.
3. Start machine engine.
4. Move the 2-speed range lever to the H (high) or L (low) position.
5. Raise up from operator's seat. Do not dismount machine.
6. Engine shut-off solenoid must de-energize in 1/2 second, causing the engine to stop.

## Using Ignition Switch

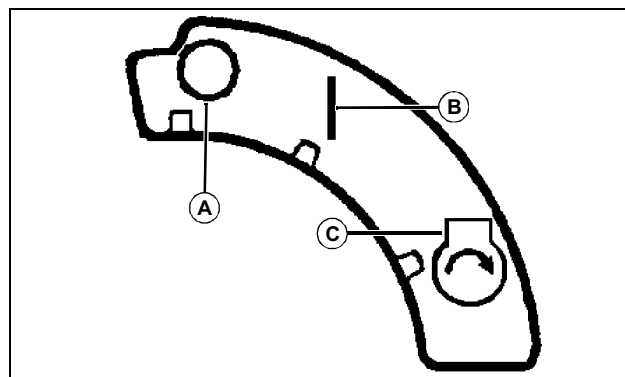

M94144

Position (A)- In this position the engine is OFF will not be running.

Position (B) - Move key to this ON position and the engine oil pressure light and battery charging light will turn on. You will also hear the engine fuel shut-off solenoid engage with a click.

Position (C) - Move key to this START position and the starter will engage the engine flywheel to start the engine. When the key is released it will automatically return to the ON position allowing the engine to run.

## Understanding Instrument Panel - Right Side

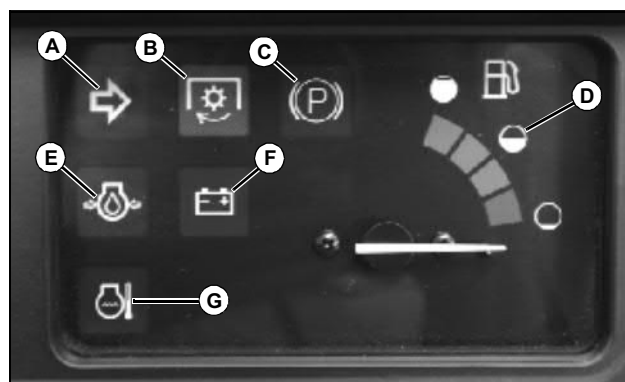

MX12100

**A -Warning Flasher/Turn Signal Indicator Light** - This indicator light will turn on and flash when the light switch is turned to the warning flasher lights ON position, the headlights, taillights, and warning flasher lights ON position or the turn signal switch is moved to the right hand turn position.

**B - PTO Engagement Light** - This light will turn on when the PTO is engaged.

**C - Park Brake Light** - This light will turn on and flash when the park brake is locked.

**D - Fuel Gauge** - Show approximately how much fuel is in



**Suggest:**

**If the above button click is invalid.**

**Please download this document**

**first, and then click the above link**

**to download the complete manual.**

**Thank you so much for reading**

# OPERATING

the fuel tank.

**E - Engine Oil Pressure Light** - This light will turn on when the ignition key is in the ON position and the engine is not running. If this light turns on while the engine is running, engine oil pressure is too low. Stop engine.

**F - Alternator/Battery Charging Light** - This light will turn on when the ignition key is in the ON position and the engine is not running. If this light turns on while the engine is running, the alternator output is too low. Move the throttle lever to the full throttle position. Stop the engine if light remains on.

**G - Engine Coolant Temperature Light** - This light will turn on when the engine coolant is approaching a dangerously hot temperature. If this light turns on during operation, remove load on machine immediately. Reduce engine to idle speed and check for something blocking air flow to the radiator and check engine coolant level. If light stays on after cleaning grille, stop engine.

## Understanding Instrument Panel - Left Side



MX15484

**A - Tachometer** - Shows engine speed. Engine speed is shown in 100's. Example: If indicator is pointing at 20 (20 x 100 = 2000 RPM). Note the special marker labeled 540. With the indicator pointing at the 540 marker, this is the proper engine speed for the 540 RPM Power Take Off (PTO).

- Slow idle speed.....1300 ± 25 rpm
- Rated speed.....3000 rpm
- Fast idle speed.....3225 ± 25 rpm

**B - Warning Flasher/Turn Signal Indicator Light** - This indicator light will turn on and flash when the light switch is turned to the warning flasher lights ON position, the headlights, taillights, and warning flasher lights ON position or the turn signal switch is moved to the left hand turn position.

**C - Hour Meter** - Shows total number of accumulated running hours at rated speed. Use the hour meter as a

guide when servicing various components of this machine.

## Using Operating Light Switch

**NOTE:** The light switch will operate only when the ignition key switch is in the ON position.

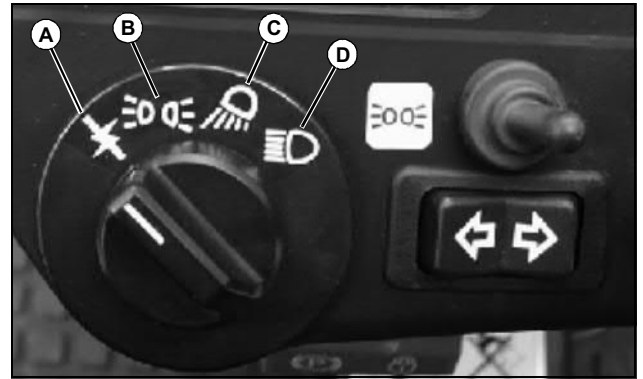

MX13672

- A - All Lights Off**
- B - Position Lights and Taillight On**
- C - Headlights and Taillight On**
- D - Headlights, Position Lights and Taillight On**

## Using Position Light and Taillight Switch

**NOTE:** Position Lights will operate with the ignition key switch in the ON or OFF position.



MX13672

Switch (A) controls the operation of the front and rear position lights.

- Move toggle switch (A) to the left. The front and rear position lights and rear taillights will illuminate.

## Using Turn Signal Switch

**NOTE:** Turn signals will operate only when the ignition key switch is in the ON position.

**<https://www.ebooklibonline.com>**

Hello dear friend!

Thank you very much for reading.

Enter the link into your browser.

The full manual is available for immediate download.

**<https://www.ebooklibonline.com>**