

**3940, 3950,  
3960 and 3970  
Forage Harvesters**

**John Deere Ottumwa Works  
TM1203 (08APR02)**

LITHO IN U.S.A.  
ENGLISH

# Contents

## SECTION 10—GENERAL INFORMATION

- Group 05—Safety
- Group 10—Specifications
- Group 15—General Information
- Group 20—Lubricants

## SECTION 20—DRIVE TRAIN

- Group 10—Diagnosing Malfunctions
- Group 15—PTO Hookup—Recirculating Ball Slip
- Group 16—PTO Hookup—Non-Metallic Bushing Type
- Group 17—PTO Hookup—Grobe Spline Type
- Group 20—Powershaft
- Group 25—Bevel Gear Case
- Group 30—Feed Roll Gear Case
- Group 35—Feed Roll Drives

## SECTION 30—HYDRAULIC SYSTEM

- Group 05—General Information
- Group 10—Diagnosing Malfunctions
- Group 15—Electrohydraulic Valve
- Group 20—Tongue Position Cylinder
- Group 25—Hydraulic Shift Cylinders
- Group 30—Cutterhead Lift System
- Group 35—Hydraulic Downstop (3940/3960)
- Group 40—Spout Cap Cylinder
- Group 45—Spout Control Motor
- Group 50—Flow Divider Valve

## SECTION 40—ELECTRICAL SYSTEM

- Group 05—Component Location
- Group 10—System Functional Checks and Diagnosing Malfunctions
- Group 15—Tests and Adjustments
- Group 20—Harness Repair
- Group 25—IRON-GARD™ Metal Detector (3950/3970)
- Group 30—SPOUT-TRAK™ (3950/3970)
- Group 35—Downstop and Float Systems (3950/3970)
- Group 40—ROW-TRAK™ (3950/3970)
- Group 45—Electrical Diagrams

## SECTION 50—CUTTERHEAD ASSEMBLY

- Group 05—Diagnosing Malfunctions
- Group 10—Feed Rolls—3940/3960
- Group 11—Feed Rolls—3950/3970
- Group 15—Smooth Roll Scraper—Stationary Knife and Adjuster
- Group 20—Radius and Feed Roll Arms
- Group 25—Knife Sharpener
- Group 30—Cutterhead and Bearings

## SECTION 60—MISCELLANEOUS

- Group 05—Auger
- Group 10—Wheels
- Group 15—Fan and Spout

## SECTION 99—DEALER FABRICATED TOOLS

- Group 05—Dealer Fabricated Tools

## Index

*All information, illustrations and specifications in this manual are based on the latest information available at the time of publication. The right is reserved to make changes at any time without notice.*

TM1203-19-08APR02

COPYRIGHT© 1998  
DEERE & COMPANY  
Moline, Illinois

All rights reserved  
A John Deere ILLUSTRATION™ Manual  
Previous Editions  
Copyright 1996, 1991, 1984, 1979 Deere & Company

# Section 10 GENERAL INFORMATION

## Contents

### Page

**Group 05—Safety** . . . . . 10-05-1

**Group 10—Specifications**

Machine Specifications . . . . . 10-10-1

Bolt and Cap Screw Torque Value Charts

    Unified Inch . . . . . 10-10-5

    Metric . . . . . 10-10-6

**Group 15—General Information** . . . . . 10-15-1

**Group 20—Lubricants**

Lubrication Specifications . . . . . 10-20-1

Grease . . . . . 10-20-2

Gear Oil . . . . . 10-20-2

Mixing of Lubricants . . . . . 10-20-3

Lubricant Storage . . . . . 10-20-3

**<https://www.ebooklibonline.com>**

Hello dear friend!

Thank you very much for reading.

Enter the link into your browser.

The full manual is available for immediate download.

**<https://www.ebooklibonline.com>**

## RECOGNIZE SAFETY INFORMATION

This is the safety-alert symbol. When you see this symbol on your machine or in this manual, be alert to the potential for personal injury.

Follow recommended precautions and safe operating practices.



DX,ALERT -19-29SEP98

T81389 -UN-07DEC88

## UNDERSTAND SIGNAL WORDS

A signal word—DANGER, WARNING, or CAUTION—is used with the safety-alert symbol. DANGER identifies the most serious hazards.

DANGER or WARNING safety signs are located near specific hazards. General precautions are listed on CAUTION safety signs. CAUTION also calls attention to safety messages in this manual.



DX,SIGNAL -19-03MAR93

TS187 -19-30SEP88

## FOLLOW SAFETY INSTRUCTIONS

Carefully read all safety messages in this manual and on your machine safety signs. Keep safety signs in good condition. Replace missing or damaged safety signs. Be sure new equipment components and repair parts include the current safety signs. Replacement safety signs are available from your John Deere dealer.

Learn how to operate the machine and how to use controls properly. Do not let anyone operate without instruction.

Keep your machine in proper working condition. Unauthorized modifications to the machine may impair the function and/or safety and affect machine life.

If you do not understand any part of this manual and need assistance, contact your John Deere dealer.

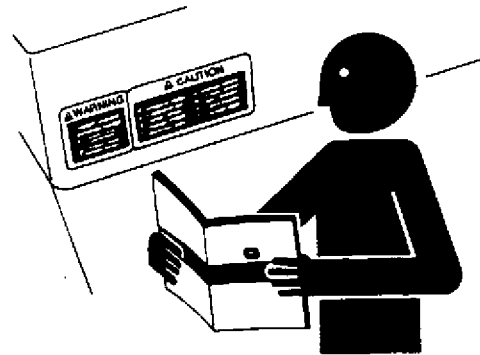

DX,READ -19-03MAR93

TS201 -UN-23AUG88

**OPERATE FORAGE HARVESTER SAFELY**

All machinery must be operated by responsible persons who have been properly instructed and delegated to do so.

Do not stand under discharge spout while harvester is operating.

Do not stand between harvesting unit and tongue while positioning tongue.

Harvesting unit may move suddenly or fall while detaching. Release stored energy from pickup float system before detaching harvesting unit.

Do not put hands or feet between tongue and frame opening while positioning tongue.

Always operate machine at rated PTO speed.

To avoid injury or death:

Disengage drives, shut off engine, and make sure electrical power is off before servicing or unplugging the harvesting unit or machine. The feed rolls can feed crop material faster than you can release your grip on the material.

Do not use your hands or feet to feed crop into the forage harvester, with or without a harvesting unit.

Do not stand between harvesting unit and tongue when detaching harvesting unit.

This forage harvester is intended for mobile field operation only. Never use or modify machine to be used in a stationary operation.

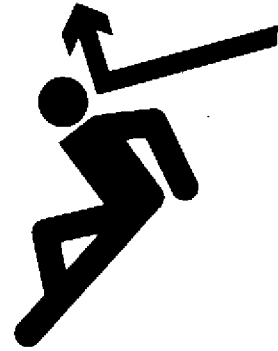

TS263 -UN-23AUG88

E32293 -UN-12SEP88

E03.3970C.U -19-29NOV91

### KEEP RIDERS OFF MACHINE

Keep riders off.

Riders are subject to injury such as being struck by foreign objects and being thrown off of the machine. Riders also obstruct the operator's view resulting in the machine being operated in an unsafe manner.



EX,9451C,H -19-13FEB97

TS249 -UN-23AUG88

10  
3  
5

### HANDLE FLUIDS SAFELY—AVOID FIRES

When you work around fuel, do not smoke or work near heaters or other fire hazards.

Store flammable fluids away from fire hazards. Do not incinerate or puncture pressurized containers.

Make sure machine is clean of trash, grease, and debris.

Do not store oily rags; they can ignite and burn spontaneously.



DX,FLAME -19-29SEP98

TS227 -UN-23AUG88

### PREPARE FOR EMERGENCIES

Be prepared if a fire starts.

Keep a first aid kit and fire extinguisher handy.

Keep emergency numbers for doctors, ambulance service, hospital, and fire department near your telephone.

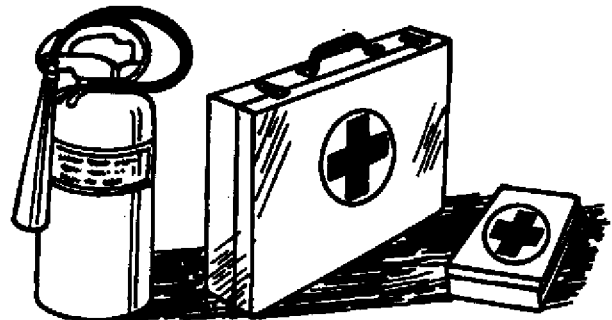

DX,FIRE2 -19-03MAR93

TS291 -UN-23AUG88

10  
05  
4

## HANDLE CHEMICAL PRODUCTS SAFELY

Direct exposure to hazardous chemicals can cause serious injury. Potentially hazardous chemicals used with John Deere equipment include such items as lubricants, coolants, paints, and adhesives.

A Material Safety Data Sheet (MSDS) provides specific details on chemical products: physical and health hazards, safety procedures, and emergency response techniques.

Check the MSDS before you start any job using a hazardous chemical. That way you will know exactly what the risks are and how to do the job safely. Then follow procedures and recommended equipment.

(See your John Deere dealer for MSDS's on chemical products used with John Deere equipment.)

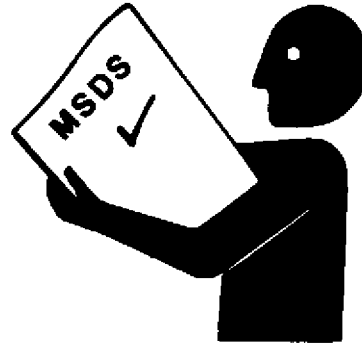

TS1132 -JUN-26NOV90

DX,MSDS,NA -19-03MAR93

## AVOID HIGH-PRESSURE FLUIDS

Escaping fluid under pressure can penetrate the skin causing serious injury.

Avoid the hazard by relieving pressure before disconnecting hydraulic or other lines. Tighten all connections before applying pressure.

Search for leaks with a piece of cardboard. Protect hands and body from high pressure fluids.

If an accident occurs, see a doctor immediately. Any fluid injected into the skin must be surgically removed within a few hours or gangrene may result. Doctors unfamiliar with this type of injury should reference a knowledgeable medical source. Such information is available from Deere & Company Medical Department in Moline, Illinois, U.S.A.

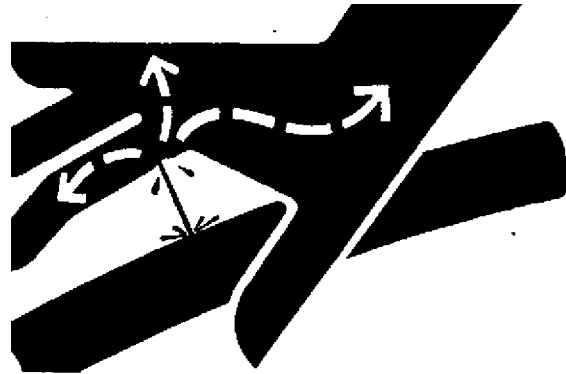

X9811 -JUN-23AUG88

DX,FLUID -19-03MAR93

### SUPPORT MACHINE PROPERLY

Always lower the attachment or implement to the ground before you work on the machine. If you must work on a lifted machine or attachment, securely support the machine or attachment.

Do not support the machine on cinder blocks, hollow tiles, or props that may crumble under continuous load. Do not work under a machine that is supported solely by a jack. Follow recommended procedures in this manual.

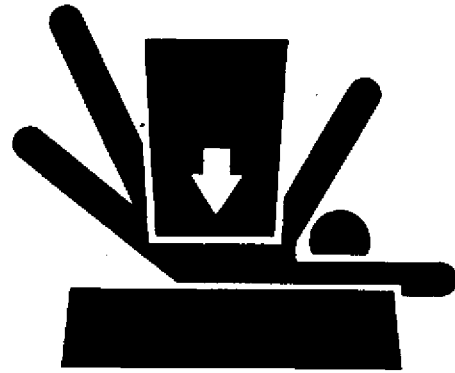

DX,LOWER -19-04JUN90

10  
51  
-JUN-23AUG88  
TS229

### WEAR PROTECTIVE CLOTHING

Wear close fitting clothing and safety equipment appropriate to the job.

Prolonged exposure to loud noise can cause impairment or loss of hearing.

Wear a suitable hearing protective device such as earmuffs or earplugs to protect against objectionable or uncomfortable loud noises.

Operating equipment safely requires the full attention of the operator. Do not wear radio or music headphones while operating machine.

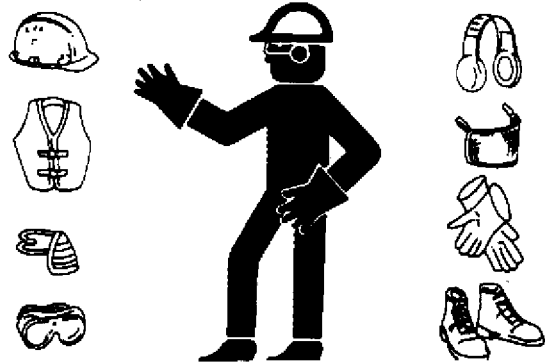

DX,WEAR -19-10SEP90

-JUN-23AUG88  
TS206

### SERVICE MACHINES SAFELY

Tie long hair behind your head. Do not wear a necktie, scarf, loose clothing, or necklace when you work near machine tools or moving parts. If these items were to get caught, severe injury could result.

Remove rings and other jewelry to prevent electrical shorts and entanglement in moving parts.

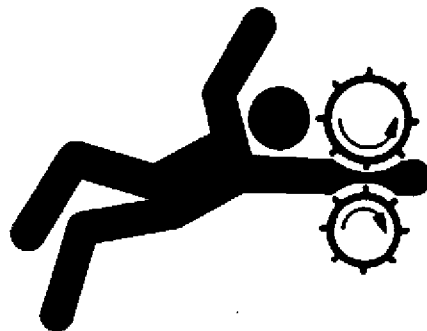

DX,LOOSE -19-04JUN90

-JUN-23AUG88  
TS228

### WORK IN CLEAN AREA

Before starting a job:

- Clean work area and machine.
- Make sure you have all necessary tools to do your job.
- Have the right parts on hand.
- Read all instructions thoroughly; do not attempt shortcuts.

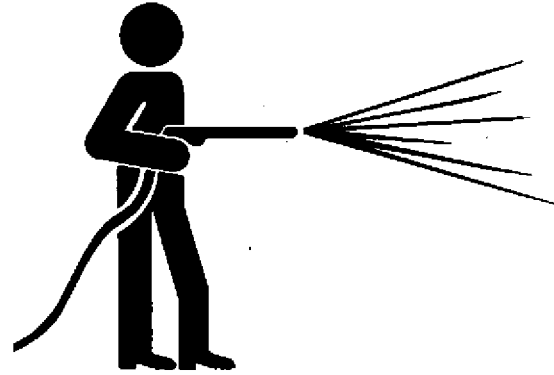

DX,CLEAN -19-04JUN90

T6642EJ -JUN-18OCT88

### ILLUMINATE WORK AREA SAFELY

Illuminate your work area adequately but safely. Use a portable safety light for working inside or under the machine. Make sure the bulb is enclosed by a wire cage. The hot filament of an accidentally broken bulb can ignite spilled fuel or oil.



DX,LIGHT -19-04JUN90

TS223 -JUN-23AUG88

### REPLACE SAFETY SIGNS

Replace missing or damaged safety signs. See the machine operator's manual for correct safety sign placement.

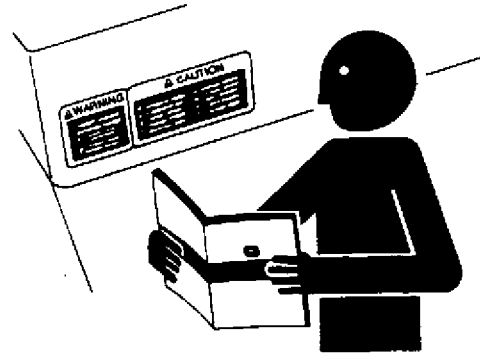

DX,SIGNS1 -19-04JUN90

TS201 -JUN-23AUG88

### USE PROPER LIFTING EQUIPMENT

Lifting heavy components incorrectly can cause severe injury or machine damage.

Follow recommended procedure for removal and installation of components in the manual.

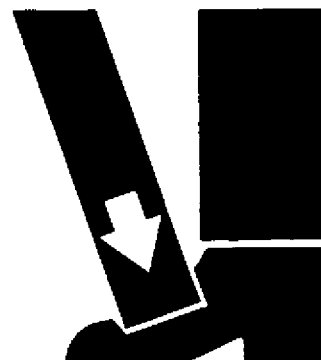

DX,LIFT -19-04JUN90

TS226 -JUN-23AUG88

## REMOVE PAINT BEFORE WELDING OR HEATING

Avoid potentially toxic fumes and dust.

Hazardous fumes can be generated when paint is heated by welding, soldering, or using a torch.

Do all work outside or in a well ventilated area. Dispose of paint and solvent properly.

Remove paint before welding or heating:

- If you sand or grind paint, avoid breathing the dust. Wear an approved respirator.
- If you use solvent or paint stripper, remove stripper with soap and water before welding. Remove solvent or paint stripper containers and other flammable material from area. Allow fumes to disperse at least 15 minutes before welding or heating.

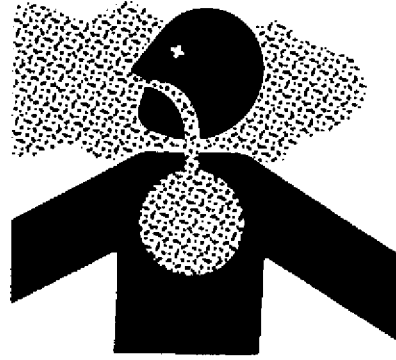

DX,PAINT -19-03MAR93

10  
05  
7  
-JUN-23AUG88  
TS220

## AVOID HEATING NEAR PRESSURIZED FLUID LINES

Flammable spray can be generated by heating near pressurized fluid lines, resulting in severe burns to yourself and bystanders. Do not heat by welding, soldering, or using a torch near pressurized fluid lines or other flammable materials. Pressurized lines can be accidentally cut when heat goes beyond the immediate flame area.



DX,TORCH -19-03MAR93

-JUN-15MAY90  
TSS953

**SERVICE TIRES SAFELY**

Explosive separation of a tire and rim parts can cause serious injury or death.

Do not attempt to mount a tire unless you have the proper equipment and experience to perform the job.

Always maintain the correct tire pressure. Do not inflate the tires above the recommended pressure. Never weld or heat a wheel and tire assembly. The heat can cause an increase in air pressure resulting in a tire explosion. Welding can structurally weaken or deform the wheel.

When inflating tires, use a clip-on chuck and extension hose long enough to allow you to stand to one side and NOT in front of or over the tire assembly. Use a safety cage if available.

Check wheels for low pressure, cuts, bubbles, damaged rims or missing lug bolts and nuts.



TS862 -JUN-12APR90

DX,TIRECP -19-24AUG90

**PRACTICE SAFE MAINTENANCE**

Understand service procedure before doing work. Keep area clean and dry.

Never lubricate, service, or adjust machine while it is moving. Keep hands, feet, and clothing from power-driven parts. Disengage all power and operate controls to relieve pressure. Lower equipment to the ground. Stop the engine. Remove the key. Allow machine to cool.

Securely support any machine elements that must be raised for service work.

Keep all parts in good condition and properly installed. Fix damage immediately. Replace worn or broken parts. Remove any buildup of grease, oil, or debris.

Disconnect battery ground cable (-) before making adjustments on electrical systems or welding on machine.



TS218 -JUN-23AUG88

DX,SERV -19-03MAR93

### USE PROPER TOOLS

Use tools appropriate to the work. Makeshift tools and procedures can create safety hazards.

Use power tools only to loosen threaded parts and fasteners.

For loosening and tightening hardware, use the correct size tools. DO NOT use U.S. measurement tools on metric fasteners. Avoid bodily injury caused by slipping wrenches.

Use only service parts meeting John Deere specifications.



9510  
-JUN-08NOV89  
TS779

DX,REPAIR -19-04JUN90

### CONSTRUCT DEALER-MADE TOOLS SAFELY

Faulty or broken tools can result in serious injury. When constructing tools, use proper, quality materials, and good workmanship.

Do not weld tools unless you have the proper equipment and experience to perform the job.

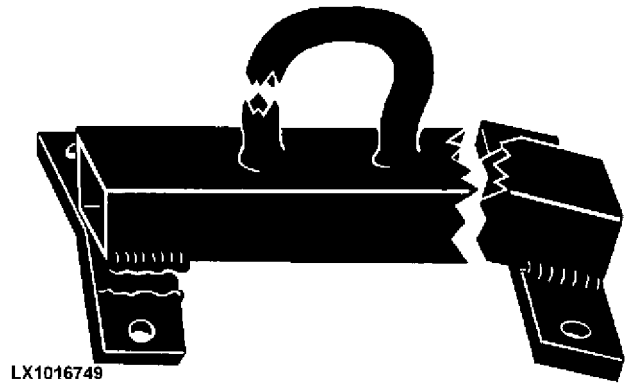

LX1016749

-JUN-01JUL97  
LX1016749

DX,SAFE,TOOLS -19-19SEP97

10  
05  
10

### DISPOSE OF WASTE PROPERLY

Improperly disposing of waste can threaten the environment and ecology. Potentially harmful waste used with John Deere equipment include such items as oil, fuel, coolant, brake fluid, filters, and batteries.

Use leakproof containers when draining fluids. Do not use food or beverage containers that may mislead someone into drinking from them.

Do not pour waste onto the ground, down a drain, or into any water source.

Air conditioning refrigerants escaping into the air can damage the Earth's atmosphere. Government regulations may require a certified air conditioning service center to recover and recycle used air conditioning refrigerants.

Inquire on the proper way to recycle or dispose of waste from your local environmental or recycling center, or from your John Deere dealer.

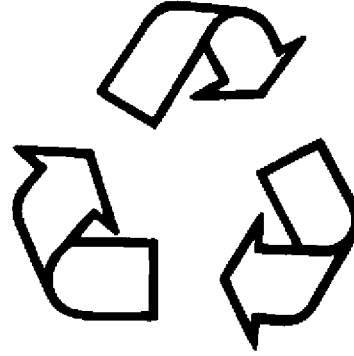

TS1133 -JUN-26NOV90

DX,DRAIN -19-03MAR93

### LIVE WITH SAFETY

Before returning machine to customer, make sure machine is functioning properly, especially the safety systems. Install all guards and shields.



TS231 -19-07OCT88

DX,LIVE -19-15APR98

**FORAGE HARVESTER SPECIFICATIONS**

**CUTTERHEAD:**

Diameter	18 in. (457 mm)
Width	
(3940/3950)	18-3/4 in. (476 mm)
(3960/3970)	22-3/4 in. (578 mm)
Number of Knives	
(3940/3950)	36
(3960/3970)	48
Knife Type	Small, straight knife in helical pattern
Knife Size	
(3940/3950)	6-13/32 x 3-21/64 in. (163 x 85 mm)
(3960/3970)	5-27/32 x 3-21/64 in. (148 x 85 mm)
Speed	850 rpm

**FEED ROLLS AND HOUSING:**

Housing Width	
(3940/3950)	18 in. (457 mm)
(3960/3970)	22 in. (559 mm)
Feed Roll Rise	6 in. (152 mm)
Feed Roll Opening	
(3940/3950)	108 in <sup>2</sup> . (696.8 cm <sup>2</sup> )
(3960/3970)	132 in <sup>2</sup> . (851.7 cm <sup>2</sup> )
Upper Feed Roll Protection	
(3940/3960)	Shear Bolt
(3950/3970)	Shear Bolt or Slip Clutch
Length of Cut	
(With Full Set of Knives)	1/4 to 1/2-in. (6.4 to 12.7 mm)
(With Half Set of Knives)	1/2 to 1 in. (12.7 to 25.4 mm)
Lower Feed Roll Protection	
(3940—3960)	Direct Drive
(3950/3970)	Slip Clutch or Direct Drive

**BLOWER FAN:**

Number of Blades	4
Diameter	32 in. (813 mm)
Speed	722 rpm or 1000 rpm (changed with interchangeable sheaves)

**CONTROLS:**

(3940/3960)	
Standard	Manual
Optional	Electro-Hydraulic
(3950/3970—Standard)	Electro-Hydraulic

**FEED ROLL DRIVE:**

Gear Case	Enclosed
Shift	
(3940/3960)	Manual or Hydraulic (Forward, Reverse and Neutral)
(3950/3970)	Hydraulic (Forward, Reverse and Neutral)

Continued on next page.

EX.3940,1005,A2-19-16NOV98

10  
10-2

TIRE SIZE AND OPERATING PRESSURE:

Standard

3940

9.5-14, 6 ply rating . . . . . 28 psi (193 kPa) (1.93 bar)

3950/3960

11L-14, 6 ply rating . . . . . 28 psi (193 kPa) (1.93 bar)

3970

11L-15, 8 ply rating . . . . . 32 psi (221 kPa) (2.21 bar)

3950/3970 (S.N. 915001— )

11L-14, 8 ply rating

Normal . . . . . 30 psi (207 kPa) (2.1 bar)

When harvesting with a 3-Row Row-Crop,

2-Row Ear Corn, or 3-Row Ear Corn . . . . . 36 psi (248 kPa) (2.5 bar)

Optional

3940

11L-14, 6 ply rating . . . . . 28 psi (193 kPa) (1.93 bar)

3960

11L-15, 8 ply rating . . . . . 32 psi (221 kPa) (2.21 bar)

3950/3970 (S.N. 915001— )

31.5 x 13.5 x 15, 6 ply rating . . . . . 30 psi (207 kPa) (2.1 bar)

Continued on next page.

EX,3940,1005,A3-19-16NOV98

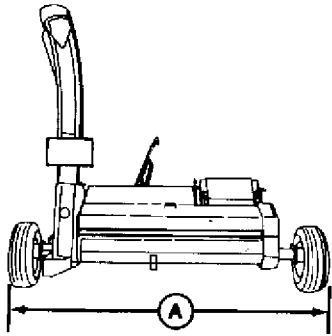

E23389 -UN-24OCT91

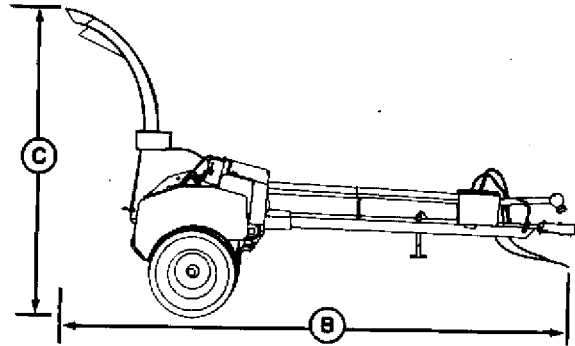

E23390 -UN-24OCT91

**OVERALL DIMENSIONS:**

**3940/3950 Width (A)**

Minimum (less wheel extensions) . . . . .	121 in. (3 075 mm)
Maximum Width (with maximum wheel extensions) . . . . .	160 in. (4 064 mm)

**3960/3970 Width (A)**

Minimum (less wheel extensions) . . . . .	122 in. (3 099 mm)
Maximum (with maximum wheel extensions) . . . . .	161 in. (4 089 mm)

**3940/3950 Length (B)**

Minimum (540 rpm) (3940 only) . . . . .	227 in. (5 766 mm)
Maximum (1000 rpm) . . . . .	284 in. (7 214 mm)

**3960/3970 Length (B)**

Minimum (1000 rpm-short tongue) . . . . .	224 in. (5 690 mm)
Maximum (1000 rpm-long tongue) . . . . .	306 in. (7 772 mm)

**Height (C)**

Minimum (no spout extension) . . . . .	106.2 in. (2697 mm)
Maximum (with spout extensions) . . . . .	179.7 in. (4564 mm)

*Continued on next page.*

EX.3940,1005,B1-19-16NOV98

10  
10  
3

10  
10  
4

**AUGER:**

Diameter ..... 11 in. (279.4 mm)  
 Speed ..... 392 or 540 rpm (through interchangeable sheaves)

**PTO SHAFT SPEED:**

(3940/3950) ..... 540 or 1000 rpm  
 (3960/3970) ..... 1000 rpm

**SIZE OF TRACTOR RECOMMENDED:**

**PTO HP**

(3940)  
 540 rpm (Cat. 5) ..... Up to 80 hp (60 kW)  
 1000 rpm (Cat. 4) ..... Up to 130 hp (97 kW)  
 (3950)  
 540 rpm (Cat. 5) ..... Up to 80 hp (60 kW)  
 1000 rpm (Cat. 5) ..... Up to 150 hp (112 kW)  
 (3960)  
 1000 rpm (Cat. 5) ..... Up to 150 hp (112 kW)  
 1000 rpm (Cat. 6) ..... Up to 180 hp (134 kW)  
 (3970)  
 1000 rpm (Cat. 5) ..... Up to 150 hp (112 kW)  
 1000 rpm (Cat. 6) (1-3/8 in. (34.9 mm) PTO Shaft Only) ..... Up to 150 hp (112 kW)  
 1000 rpm (Cat. 6)  
 (S.N. —915000) ..... Up to 190 hp (143 kW)  
 (Cat. 6) (S.N. 915001— ) ..... Up to 200 hp (149 kW)

**PTO HOOKUP:**

	<b>RPM</b>	<b>PTO Size</b>	<b>Spline</b>	<b>Type</b>
Category 4	1000	1-3/8 in. (34.9 mm)	21	Non-Metallic Bushing Type
Category 5	540	1-3/8 in. (34.9 mm)	6	Recirculating Ball Slip
	1000	1-3/8 in. (34.9 mm)	21	Non-Metallic Bushing Type Recirculating Ball Slip (Optional)
Category 6	1000	1-3/8 in. (34.9 mm)	21	Grobe Spline
	1000	1-3/4 in. (44.4 mm)	20	Recirculating Ball Slip Grobe Spline

(Specifications and design subject to change without notice.)

**UNIFIED INCH BOLT AND CAP SCREW TORQUE VALUES**

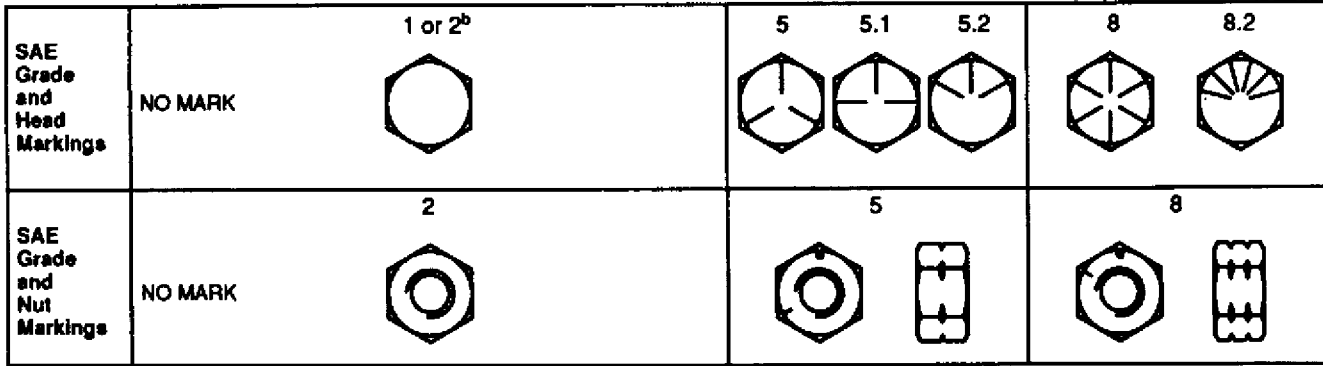

Size	Grade 1				Grade 2 <sup>b</sup>				Grade 5, 5.1, or 5.2				Grade 8 or 8.2			
	Lubricated <sup>a</sup>		Dry <sup>a</sup>		Lubricated <sup>a</sup>		Dry <sup>a</sup>		Lubricated <sup>a</sup>		Dry <sup>a</sup>		Lubricated <sup>a</sup>		Dry <sup>a</sup>	
	N·m	lb-ft	N·m	lb-ft	N·m	lb-ft	N·m	lb-ft	N·m	lb-ft	N·m	lb-ft	N·m	lb-ft	N·m	lb-ft
1/4	3.7	2.8	4.7	3.5	6	4.5	7.5	5.5	9.5	7	12	9	13.5	10	17	12.5
5/16	7.7	5.5	10	7	12	9	15	11	20	15	25	18	28	21	35	26
3/8	14	10	17	13	22	16	27	20	35	26	44	33	50	36	63	46
7/16	22	16	28	20	35	26	44	32	55	41	70	52	80	58	100	75
1/2	33	25	42	31	53	39	67	50	85	63	110	80	120	90	150	115
9/16	48	36	60	45	75	56	95	70	125	90	155	115	175	130	225	160
5/8	67	50	85	62	105	78	135	100	170	125	215	160	240	175	300	225
3/4	120	87	150	110	190	140	240	175	300	225	375	280	425	310	550	400
7/8	190	140	240	175	190	140	240	175	490	360	625	450	700	500	875	650
1	290	210	360	270	290	210	360	270	725	540	925	675	1050	750	1300	975
1-1/8	400	300	510	375	400	300	510	375	900	675	1150	850	1450	1075	1850	1350
1-1/4	570	425	725	530	570	425	725	530	1300	950	1650	1200	2050	1500	2600	1950
1-3/8	750	550	950	700	750	550	950	700	1700	1250	2150	1550	2700	2000	3400	2550
1-1/2	1000	725	1250	925	990	725	1250	930	2250	1650	2850	2100	3600	2650	4550	3350

DO NOT use these values if a different torque value or tightening procedure is given for a specific application. Torque values listed are for general use only. Check tightness of fasteners periodically.

Shear bolts are designed to fail under predetermined loads. Always replace shear bolts with identical grade.

<sup>a</sup> "Lubricated" means coated with a lubricant such as engine oil, or fasteners with phosphate and oil coatings. "Dry" means plain or zinc plated without any lubrication.

<sup>b</sup> Grade 2 applies for hex cap screws (not hex bolts) up to 152 mm (6-in.) long. Grade 1 applies for hex cap screws over 152 mm (6-in.) long, and for all other types of bolts and screws of any length.

Fasteners should be replaced with the same or higher grade. If higher grade fasteners are used, these should only be tightened to the strength of the original.

Make sure fasteners threads are clean and that you properly start thread engagement. This will prevent them from failing when tightening.

Tighten plastic insert or crimped steel-type lock nuts to approximately 50 percent of the dry torque shown in the chart, applied to the nut, not to the bolt head. Tighten toothed or serrated-type lock nuts to the full torque value.

10-10-5  
-19-04/MAR91  
TS1162

**METRIC BOLT AND CAP SCREW TORQUE VALUES**

10  
10  
6

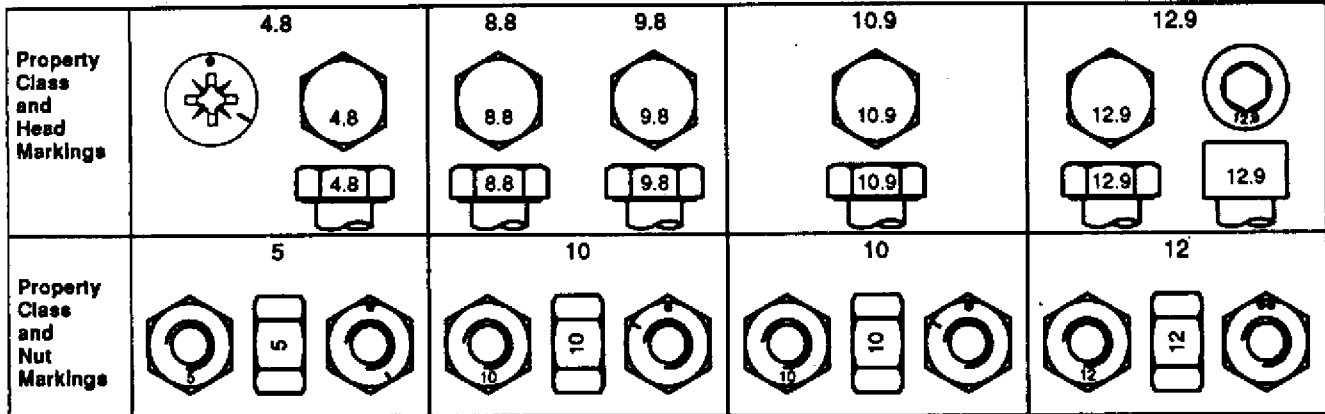

TS1163 -19-041VAR91

Size	Class 4.8				Class 8.8 or 9.8				Class 10.9				Class 12.9			
	Lubricated <sup>a</sup>		Dry <sup>a</sup>		Lubricated <sup>a</sup>		Dry <sup>a</sup>		Lubricated <sup>a</sup>		Dry <sup>a</sup>		Lubricated <sup>a</sup>		Dry <sup>a</sup>	
	N-m	lb-ft	N-m	lb-ft	N-m	lb-ft	N-m	lb-ft	N-m	lb-ft	N-m	lb-ft	N-m	lb-ft	N-m	lb-ft
M6	4.8	3.5	6	4.5	9	6.5	11	8.5	13	9.5	17	12	15	11.5	19	14.5
M8	12	8.5	15	11	22	16	28	20	32	24	40	30	37	28	47	35
M10	23	17	29	21	43	32	55	40	63	47	80	60	75	55	95	70
M12	40	29	50	37	75	55	95	70	110	80	140	105	130	95	165	120
M14	63	47	80	60	120	88	150	110	175	130	225	165	205	150	260	190
M16	100	73	125	92	190	140	240	175	275	200	350	255	320	240	400	300
M18	135	100	175	125	260	195	330	250	375	275	475	350	440	325	560	410
M20	190	140	240	180	375	275	475	350	530	400	675	500	625	460	800	580
M22	260	190	330	250	510	375	650	475	725	540	925	675	850	625	1075	800
M24	330	250	425	310	650	475	825	600	925	675	1150	850	1075	800	1350	1000
M27	490	360	625	450	950	700	1200	875	1350	1000	1700	1250	1600	1150	2000	1500
M30	675	490	850	625	1300	950	1650	1200	1850	1350	2300	1700	2150	1600	2700	2000
M33	900	675	1150	850	1750	1300	2200	1650	2500	1850	3150	2350	2900	2150	3700	2750
M36	1150	850	1450	1075	2250	1650	2850	2100	3200	2350	4050	3000	3750	2750	4750	3500

DO NOT use these values if a different torque value or tightening procedure is given for a specific application. Torque values listed are for general use only. Check tightness of fasteners periodically.

Make sure fasteners threads are clean and that you properly start thread engagement. This will prevent them from failing when tightening.

Shear bolts are designed to fail under predetermined loads. Always replace shear bolts with identical property class.

Tighten plastic insert or crimped steel-type lock nuts to approximately 50 percent of the dry torque shown in the chart, applied to the nut, not to the bolt head. Tighten toothed or serrated-type lock nuts to the full torque value.

Fasteners should be replaced with the same or higher property class. If higher property class fasteners are used, these should only be tightened to the strength of the original.

<sup>a</sup> "Lubricated" means coated with a lubricant such as engine oil, or fasteners with phosphate and oil coatings. "Dry" means plain or zinc plated without any lubrication.

GENERAL

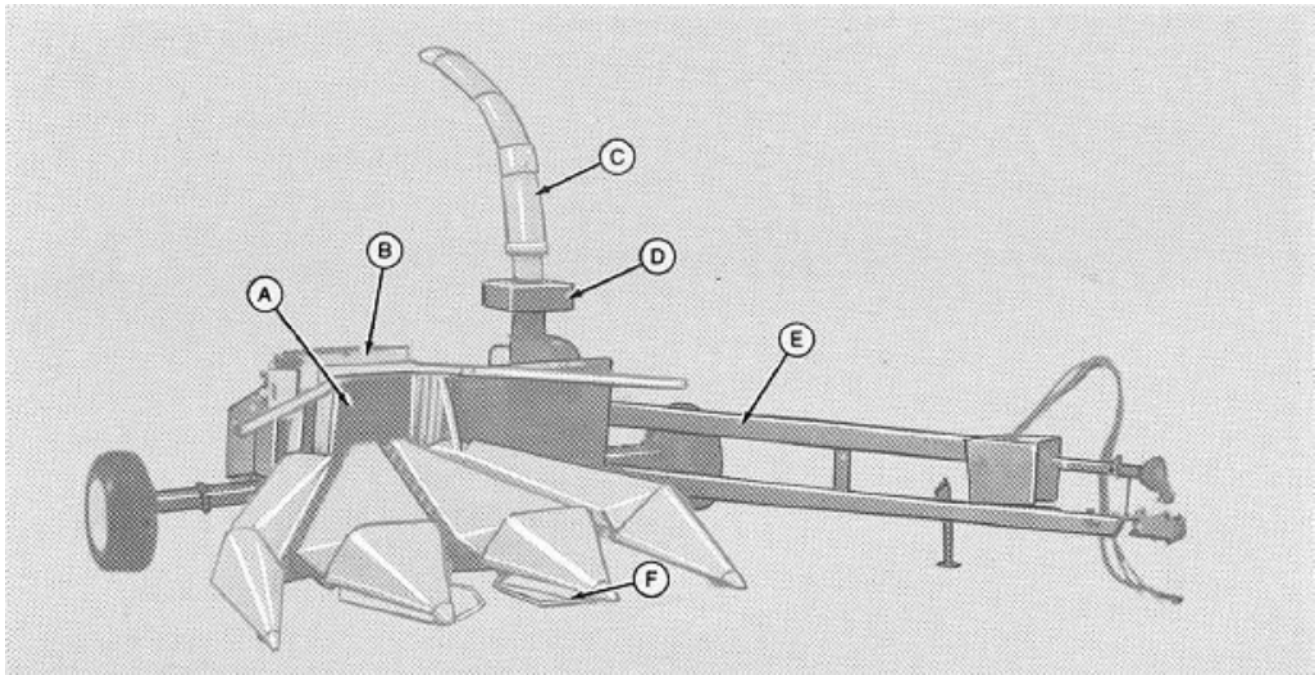

E23391  
-JUN-13DEC91

A—Feed Rolls  
B—Cutterhead Assembly

C—Spout  
D—Automatic SPOUT TRAK  
(Optional)

E—Tongue  
F—Automatic ROW TRAK  
(Optional)

*Harvester with Row-Crop Attachment*

The 3940 was one or two row pull-type forage harvester. It was available with 1000 rpm ASAE Category 4 hookup or with 540 rpm (3940) ASAE Category 5 hook-up.

The 3950 is a two or three row pull-type forage harvester. The 540 rpm ASAE Category 5 hookup is no longer available.

The 3960 was a two or three row machine for tractors up to 134 kW (180 hp). It is available in 1000 rpm only with ASAE Category 5 or 6, 34.9 mm (1-3/8-inch) PTO, or Category 6, 44 mm (1-3/4-inch) PTO.

The 3970 is for use with tractors up to 112 kW (150 hp) when equipped with 1000 rpm ASAE Category 5 or 6 hookup 34.9 mm (1-3/8-inch) PTO, or 149 kW (200 hp) with Category 6, 44 mm (1-3/4-inch) PTO.

The harvesters feature the new Dura-Drum cutterheads which produce a uniformly cut forage product. A metal detector, that is optional on the 3950 and 3970, stops the feed rolls before ferrous metal enters the cutterhead. Segmented cutterhead knives help reduce damage due to foreign material and cost of replacement if damage does occur.

The two speed fan gives a high speed (1000 rpm) for "hard-to-blow" crops and a low speed (722 rpm) for "easy-to-blow" crops that require less power.

The basic components of the harvesters include the main frame and wheels, feed rolls (A), cutterhead assembly (B), spout (C), optional SPOUT TRAK (D), tongue (E), and optional ROW TRAK (F).

Beginning with 1999 model year production, a transport lighting package (not shown) has become a standard feature.

EX.3940,1015,A1-19-16NOV98

**LUBRICATION SPECIFICATIONS**

Carefully written and illustrated lubrication instructions are included in the operator's manual furnished with your customer's machine. Remind the customer to follow these instructions.

For your convenience, the following chart shows capacities and types of lubricants for the harvester.

<b>Component</b>	<b>Capacity</b>	<b>Type of Lubricant</b>	<b>Interval of Service</b>
Roller Chains		John Deere PT 508 Special Lubricant or SAE 30 engine oil	Daily
Feed Roll Drive Gear Case	3 qts. (2.8 L)	SAE 85-140 API-GL5 Gear Lubricant	Every 100 Hours or Annually
Bevel Drive Gear Case			
One Piece Housing	4 qt (3.8 L)	SAE 85-140 API-GL5 Gear Lubricant	Every 100 Hours or Annually
Split Case Housing	3.7 qt (3.5 L)	SAE 85-140 API-GL5 Gear Lubricant	Every 100 Hours or Annually
Wheel Bearings		John Deere Multi-Purpose Lubricant or an equivalent SAE Multipurpose type grease	Each Season

EX,3940,1020,A -19-16JAN92

## GREASE

Use grease based on NLGI consistency numbers and the expected air temperature range during the service interval.

The following greases are preferred:

- John Deere HIGH TEMPERATURE EP GREASE
- John Deere MOLY HIGH TEMPERATURE EP GREASE
- John Deere GREASE-GARD™

Other greases may be used if they meet one of the following:

- NLGI Performance Classification GC-LB

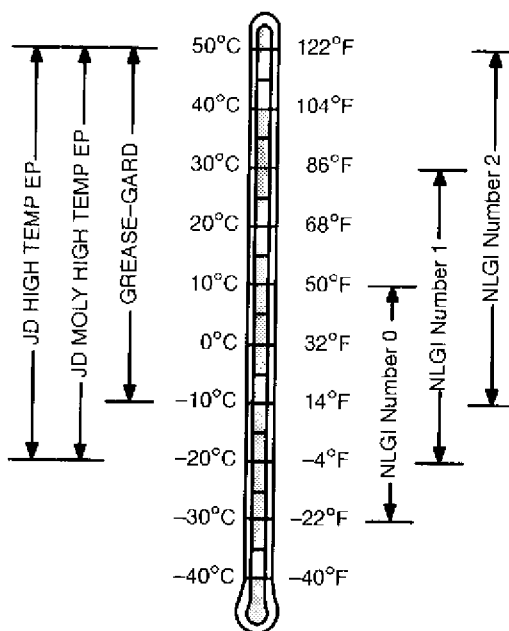

DX.GREA1 -19-18MAR96

TS1654 -JUN-14MAR96

## GEAR OIL

Use oil viscosity based on the expected air temperature range during the period between oil changes.

The following oils are preferred:

- John Deere EXTREME-GARD™
- John Deere GL-5 GEAR LUBRICANT

Other oils may be used if they meet the following:

- API Service Classification GL-5

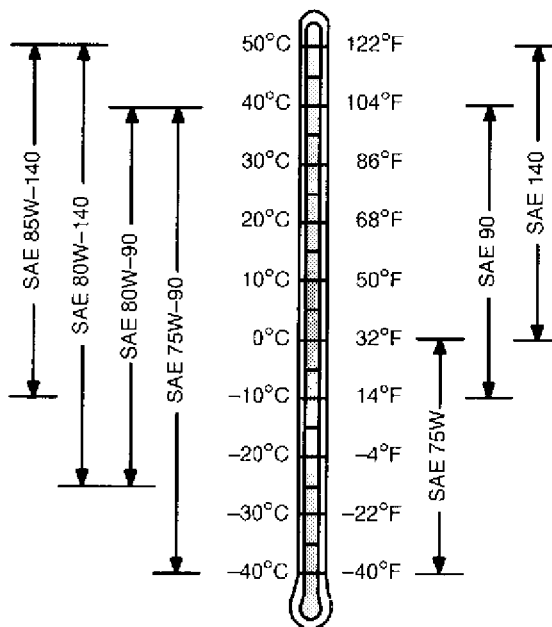

DX.GEOL -19-18MAR96

TS1653 -JUN-14MAR96



**Suggest:**

**If the above button click is invalid.**

**Please download this document**

**first, and then click the above link**

**to download the complete manual.**

**Thank you so much for reading**

## MIXING OF LUBRICANTS

In general, avoid mixing different brands or types of oil. Oil manufacturers blend additives in their oils to meet certain specifications and performance requirements.

Mixing different oils can interfere with the proper functioning of these additives and degrade lubricant performance.

Consult your John Deere dealer to obtain specific information and recommendations.

DX,LUBMIX -19-18MAR96

## LUBRICANT STORAGE

Your equipment can operate at top efficiency only when clean lubricants are used.

Use clean containers to handle all lubricants.

Whenever possible, store lubricants and containers in an area protected from dust, moisture, and other contamination. Store containers on their side to avoid water and dirt accumulation.

Make certain that all containers are properly marked to identify their contents.

Properly dispose of all old containers and any residual lubricant they may contain.

DX,LUBST -19-18MAR96

**<https://www.ebooklibonline.com>**

Hello dear friend!

Thank you very much for reading.

Enter the link into your browser.

The full manual is available for immediate download.

**<https://www.ebooklibonline.com>**