

JOHN DEERE
WORLDWIDE COMMERCIAL & CONSUMER
EQUIPMENT DIVISION

Professional Greens Mower
2500, 2500A, and 2500E

TM1757 DEC05

TECHNICAL MANUAL



JOHN DEERE

North American Version
Litho in U.S.A.

INTRODUCTION

Manual Description

This technical manual is written for an experienced technician and contains sections that are specifically for this product. It is a part of a total product support program.

The manual is organized so that all the information on a particular system is kept together. The order of grouping is as follows:

- Table of Contents
- Specifications and Information
- Identification Numbers
- Tools and Materials
- Component Location
- Schematics and Harnesses
- Theory of Operation
- Operation and Diagnostics
- Diagnostics
- Tests and Adjustments
- Repair
- Other

NOTE: Depending on the particular section or system being covered, not all of the above groups may be used.

The bleed tabs for the pages of each section will align with the sections listed on this page. Page numbering is consecutive from the beginning of the Safety section through the last section.

We appreciate your input on this manual. If you find any errors or want to comment on the layout of the manual please contact us.

Safety

Specifications and Information

Gas Engine

Diesel Engine

Electrical

Power Train

Hydraulics

Steering

Brakes

Attachments

Miscellaneous

All information, illustrations and specifications in this manual are based on the latest information at the time of publication. The right is reserved to make changes at any time without notice.

COPYRIGHT© 2005

Deere & Co.

John Deere Worldwide Commercial and Consumer Equipment Division

All rights reserved

Previous Editions

COPYRIGHT© 2003, 2004, 2005

SAFETY

Recognize Safety Information

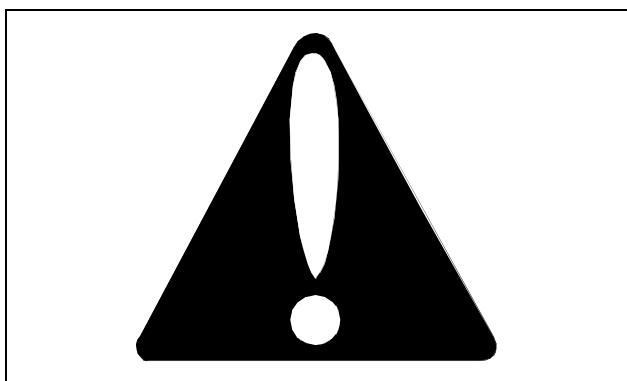

MIF

This is the safety-alert symbol. When you see this symbol on your machine or in this manual, be alert to the potential for personal injury.

Follow recommended precautions and safe servicing practices.

Understand Signal Words

A signal word - DANGER, WARNING, or CAUTION - is used with the safety-alert symbol. DANGER identifies the most serious hazards.

DANGER or WARNING safety signs are located near specific hazards. General precautions are listed on CAUTION safety signs. CAUTION also calls attention to safety messages in this manual.

Replace Safety Signs

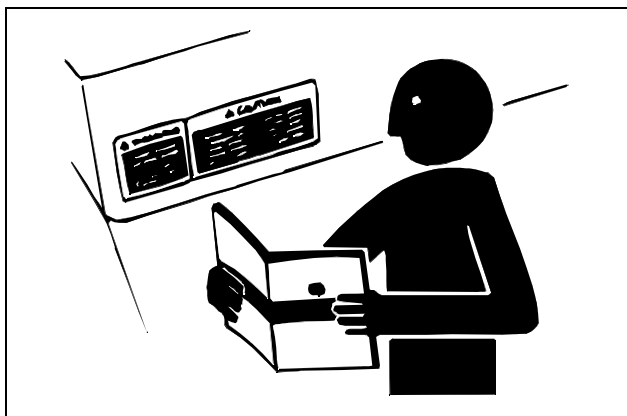

MIF

Replace missing or damaged safety signs. See the machine operator's manual for correct safety sign placement.

Handle Fluids Safely - Avoid Fires

Be Prepared For Emergencies

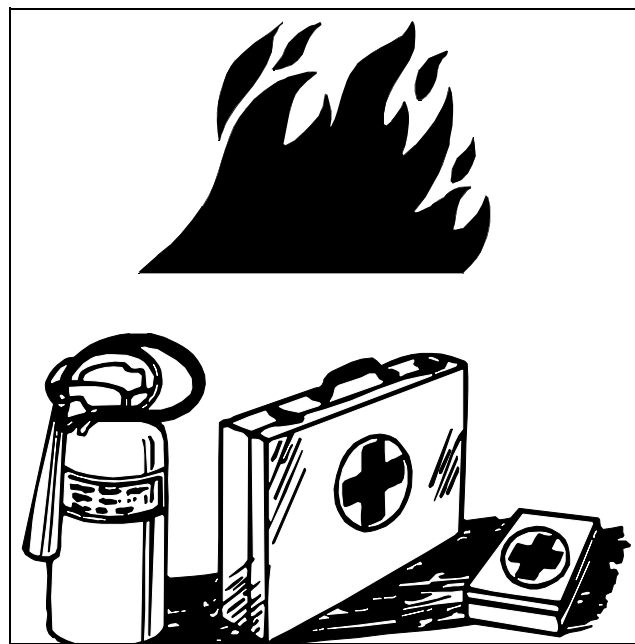

MIF

- When you work around fuel, do not smoke or work near heaters or other fire hazards.
- Store flammable fluids away from fire hazards. Do not incinerate or puncture pressurized containers.
- Make sure machine is clean of trash, grease, and debris.
- Do not store oily rags; they can ignite and burn spontaneously.
- Be prepared if a fire starts.
- Keep a first aid kit and fire extinguisher handy.
- Keep emergency numbers for doctors, ambulance service, hospital, and fire department near your telephone.

Use Care In Handling and Servicing Batteries

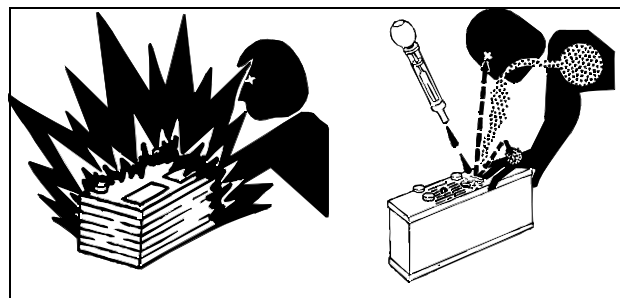

MIF

<https://www.ebooklibonline.com>

Hello dear friend!

Thank you very much for reading.

Enter the link into your browser.

The full manual is available for immediate download.

<https://www.ebooklibonline.com>

SAFETY

Prevent Battery Explosions

- Keep sparks, lighted matches, and open flame away from the top of battery. Battery gas can explode.
- Never check battery charge by placing a metal object across the posts. Use a volt-meter or hydrometer.
- Do not charge a frozen battery; it may explode. Warm battery to 16°C (60°F).

Prevent Acid Burns

- Sulfuric acid in battery electrolyte is poisonous. It is strong enough to burn skin, eat holes in clothing, and cause blindness if splashed into eyes.

Avoid acid burns by:

1. Filling batteries in a well-ventilated area.
2. Wearing eye protection and rubber gloves.
3. Avoiding breathing fumes when electrolyte is added.
4. Avoiding spilling or dripping electrolyte.
5. Use proper jump start procedure.

If you spill acid on yourself:

1. Flush your skin with water.
2. Apply baking soda or lime to help neutralize the acid.
3. Flush your eyes with water for 10 - 15 minutes.
4. Get medical attention immediately.

If acid is swallowed:

1. Drink large amounts of water or milk.
2. Then drink milk of magnesia, beaten eggs, or vegetable oil.
3. Get medical attention immediately.

Wear Protective Clothing

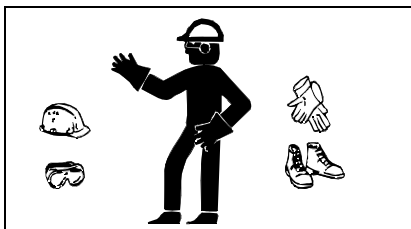

Wear close fitting clothing and safety equipment appropriate to the job.

Prolonged exposure to loud noise can cause impairment or loss of hearing. Wear a suitable hearing protective device such as earmuffs or earplugs to protect against objectionable or uncomfortable loud noises.

Operating equipment safely requires the full attention of the operator. Do not wear radio or music headphones while operating machine.

Use Care Around High-Pressure Fluid Lines

Avoid High-Pressure Fluids

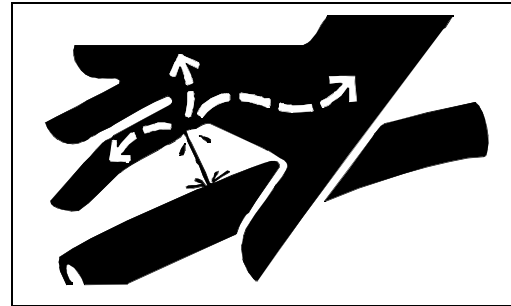

MIF

Escaping fluid under pressure can penetrate the skin causing serious injury.

Avoid injury from escaping fluid under pressure by stopping the engine and relieving pressure in the system before disconnecting or connecting hydraulic or other lines. Tighten all connections before applying pressure.

Search for leaks with a piece of cardboard. Protect hands and body from high pressure fluids.

If an accident occurs, see a doctor immediately. Any fluid injected into the skin must be surgically removed within a few hours or gangrene may result. Doctors unfamiliar with this type of injury should reference a knowledgeable medical source. Such information is available from Deere & Company Medical Department in Moline, Illinois, U.S.A.

Avoid Heating Near Pressurized Fluid Lines



MIF

Flammable spray can be generated by heating near pressurized fluid lines, resulting in severe burns to yourself and bystanders. Do not heat by welding, soldering, or using a torch near pressurized fluid lines or other flammable materials. Pressurized lines can be accidentally cut when heat goes beyond the immediate flame area.

SAFETY

Service Machines Safely

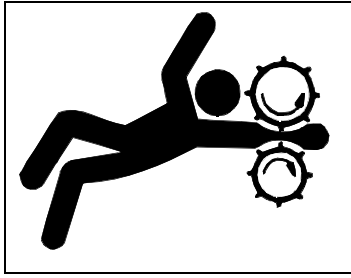

MIF

Tie long hair behind your head. Do not wear a necktie, scarf, loose clothing, or necklace when you work near machine tools or moving parts. If these items were to get caught, severe injury could result.

Remove rings and other jewelry to prevent electrical shorts and entanglement in moving parts.

Use Proper Tools

Use tools appropriate to the work. Makeshift tools and procedures can create safety hazards. Use power tools only to loosen threaded parts and fasteners. For loosening and tightening hardware, use the correct size tools. Do not use U.S. measurement tools on metric fasteners. Avoid bodily injury caused by slipping wrenches. Use only service parts meeting John Deere specifications.

Park Machine Safely

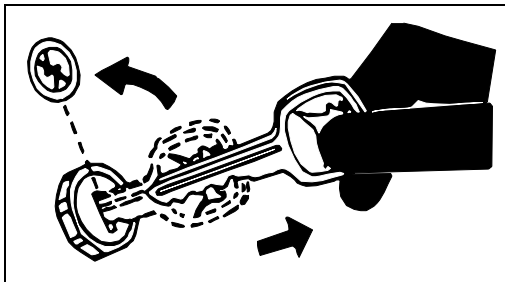

MIF

Before working on the machine:

1. Lower all equipment to the ground.
2. Stop the engine and remove the key.
3. Disconnect the battery ground strap.
4. Hang a "Do Not Operate" tag in operator station.

Support Machine Properly and Use Proper Lifting Equipment

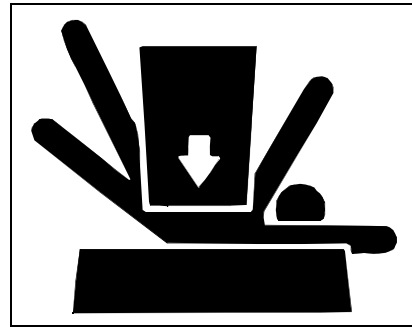

MIF

If you must work on a lifted machine or attachment, securely support the machine or attachment.

Do not support the machine on cinder blocks, hollow tiles, or props that may crumble under continuous load. Do not work under a machine that is supported solely by a jack. Follow recommended procedures in this manual.

Lifting heavy components incorrectly can cause severe injury or machine damage. Follow recommended procedure for removal and installation of components in the manual.

Work In Clean Area

Before starting a job:

1. Clean work area and machine.
2. Make sure you have all necessary tools to do your job.
3. Have the right parts on hand.
4. Read all instructions thoroughly; do not attempt shortcuts.

Using High Pressure Washers

Directing pressurized water at electronic/electrical components or connectors, bearings, hydraulic seals, fuel injection pumps or other sensitive parts and components may cause product malfunctions. Reduce pressure and spray at a 45 to 90 degree angle.

Illuminate Work Area Safely

Illuminate your work area adequately but safely. Use a portable safety light for working inside or under the machine. Make sure the bulb is enclosed by a wire cage. The hot filament of an accidentally broken bulb can ignite spilled fuel or oil.

SAFETY

Work In Ventilated Area

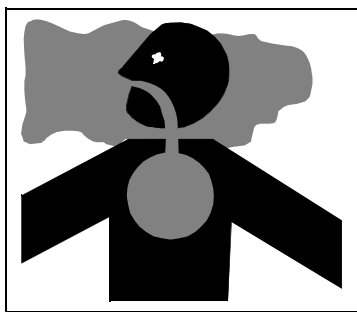

MIF

Engine exhaust fumes can cause sickness or death. If it is necessary to run an engine in an enclosed area, remove the exhaust fumes from the area with an exhaust pipe extension.

If you do not have an exhaust pipe extension, open the doors and get outside air into the area.

Warning: California Proposition 65 Warning

Gasoline engine exhaust from this product contains chemicals known to the State of California to cause cancer, birth defects, or other reproductive harm.

Diesel engine exhaust and some of its constituents are known to the State of California to cause cancer, birth defects, and other reproductive harm.

Remove Paint Before Welding or Heating

Avoid potentially toxic fumes and dust. Hazardous fumes can be generated when paint is heated by welding, soldering, or using a torch. Do all work outside or in a well ventilated area. Dispose of paint and solvent properly. Remove paint before welding or heating: If you sand or grind paint, avoid breathing the dust. Wear an approved respirator. If you use solvent or paint stripper, remove stripper with soap and water before welding. Remove solvent or paint stripper containers and other flammable material from area. Allow fumes to disperse at least 15 minutes before welding or heating.

Avoid Harmful Asbestos Dust

Avoid breathing dust that may be generated when handling components containing asbestos fibers. Inhaled asbestos fibers may cause lung cancer.

Components in products that may contain asbestos fibers are brake pads, brake band and lining assemblies, clutch plates, and some gaskets. The asbestos used in these components is usually found in a resin or sealed in some way. Normal handling is not hazardous as long as airborne dust containing asbestos is not generated.

Avoid creating dust. Never use compressed air for cleaning. Avoid brushing or grinding material containing asbestos. When servicing, wear an approved respirator. A special vacuum cleaner is recommended to clean asbestos. If not available, apply a mist of oil or water on the material containing asbestos. Keep bystanders away from the area.

Service Tires Safely

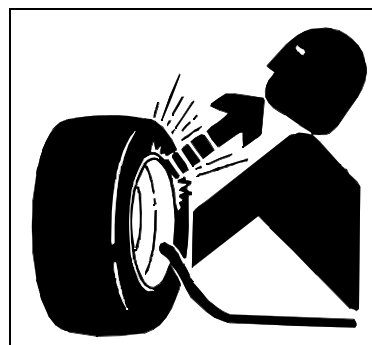

MIF

Explosive separation of a tire and rim parts can cause serious injury or death.

Do not attempt to mount a tire unless you have the proper equipment and experience to perform the job.

Always maintain the correct tire pressure. Do not inflate the tires above the recommended pressure. Never weld or heat a wheel and tire assembly. The heat can cause an increase in air pressure resulting in a tire explosion. Welding can structurally weaken or deform the wheel.

When inflating tires, use a clip-on chuck and extension hose long enough to allow you to stand to one side and not in front of or over the tire assembly. Use a safety cage if available.

Check wheels for low pressure, cuts, bubbles, damaged rims or missing lug bolts and nuts.

SAFETY

Avoid Injury From Rotating Blades, Augers and PTO Shafts

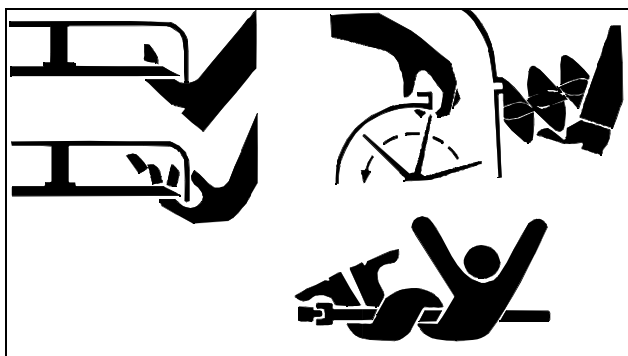

MIF

Keep hands and feet away while machine is running. Shut off power to service, lubricate or remove mower blades, augers or PTO shafts.

Service Cooling System Safely

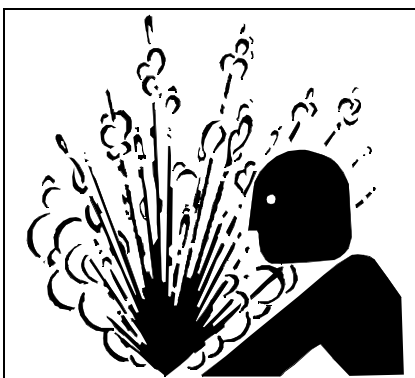

MIF

Explosive release of fluids from pressurized cooling system can cause serious burns.

Shut off machine. Only remove filler cap when cool enough to touch with bare hands. Slowly loosen cap to first stop to relieve pressure before removing completely.

Handle Chemical Products Safely

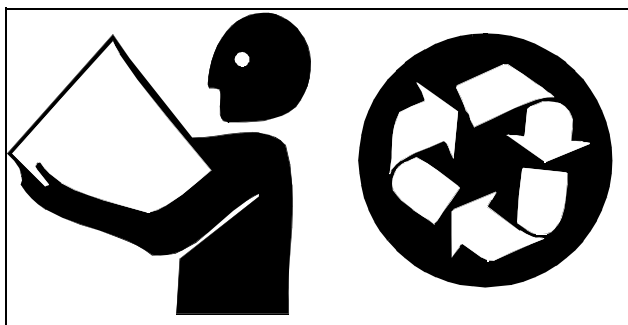

MIF

Direct exposure to hazardous chemicals can cause serious injury. Potentially hazardous chemicals used with John Deere equipment include such items as lubricants, coolants, paints, and adhesives.

A Material Safety Data Sheet (MSDS) provides specific details on chemical products: physical and health hazards, safety procedures, and emergency response techniques. Check the MSDS before you start any job using a hazardous chemical. That way you will know exactly what the risks are and how to do the job safely. Then follow procedures and recommended equipment.

Dispose Of Waste Properly

Improperly disposing of waste can threaten the environment and ecology. Potentially harmful waste used with John Deere equipment include such items as oil, fuel, coolant, brake fluid, filters, and batteries. Use leakproof containers when draining fluids. Do not use food or beverage containers that may mislead someone into drinking from them. Do not pour waste onto the ground, down a drain, or into any water source. Inquire on the proper way to recycle or dispose of waste from your local environmental or recycling center, or from your John Deere dealer.

Live With Safety



MIF

Before returning machine to customer, make sure machine is functioning properly, especially the safety systems. Install all guards and shields.

SPECIFICATIONS AND INFORMATION TABLE OF CONTENTS

Table of Contents

Specifications	9
General Vehicle Specifications.....	9
Repair Information.....	12
Metric Fastener Torque Values	12
Metric Fastener Torque Values - Grade 7	13
Inch Fastener Torque Values	14
O-Ring Seal Service Recommendations	15
Fuel	19
Using Proper Fuel	19
Oils & Lubricants	20
Engine Oil	20
Hydrostatic Transmission and Hydraulic Oil.....	20
Grease.....	21
Alternative Lubricants.....	21
Synthetic Lubricants	21
Lubricant Storage	21
Mixing of Lubricants	21
Oil Filters	22
Coolant Specifications	22
Engine Coolant.....	22
Engine Coolant Drain Interval	23
Identification Numbers.....	24
Machine Identification Number Locations	24
Operational Checkout	25
Interlock System Operation	25
General Information.....	26
Diesel Engine Air Filter Restriction Indicator Check	26
Hydraulic Reservoir Oil Level Check.....	26
Hydraulic Oil Filter Restriction Indicator Check	27
Start Circuit Check	28
Electronic Control Module Check.....	28

SPECIFICATIONS AND INFORMATION SPECIFICATIONS

Specifications

General Vehicle Specifications

NOTE: Specifications and design subject to change without notice.

Gasoline Engine

Make	Kawasaki
Type	4 Cycle, V-Twin
Model	FD620D
Displacement	617 mL (37.7 cu in.)
Aspiration	Natural
Cooling System	Liquid cooled
Cooling System Capacity	3.5 L (3.7 qt)
Lubrication	Full pressure
Engine Oil Capacity (With Filter)	1.9 L (2.0 qt)
Oil Filter	Replaceable, full flow
Valving	Overhead valves
Air Cleaner	Paper element with foam pre-cleaner
Bore	79 mm (3.11 in.)
Stroke	68 mm (2.68 in.)
Compression Ratio	9.0:1
Slow Idle	1550 ± 100 rpm
Fast Idle	3400 ± 50 rpm

Fuel System - Gasoline Engine

Fuel Tank Location	Behind operator seat
Fuel Tank Capacity	32.2 L (8.5 gal)
Fuel (Minimum Octane)	Unleaded gasoline, 87 octane
Fuel Delivery	Electric fuel pump
Carburetor	Float-type, down draft
Fuel Filter	Replaceable element
Gasoline/Alcohol Blends	Up to 10% Ethyl Alcohol/90% Unleaded (by volume)
Gasoline/Ether Blends	Up to 15% MTBE/85% Unleaded (by volume)
Fuel Shutoff Solenoid	Below carburetor float bowl

SPECIFICATIONS AND INFORMATION SPECIFICATIONS

Diesel Engine

Make	Yanmar
Type	4 Cycle, 3 cylinder, in-line
Model	3TNE68
Displacement	784 mL (47.8 cu in.)
Aspiration	Natural
Cooling System	Liquid cooled
Cooling System Capacity	3.5 L (3.7 qt)
Lubrication	Full pressure
Engine Oil Capacity (With Filter)	2.2 L (2.3 qt)
Oil Filter	Replaceable, full flow
Valving	Overhead valves
Air Cleaner	Semi-cyclone, dry type duel stage
Bore	68 mm (2.68 in.)
Stroke	72 mm (2.83 in.)
Compression Ratio	23:1
Slow Idle	1450 ± 100 rpm
Fast Idle	3225 ± 50 rpm

Fuel System - Diesel Engine

Fuel Tank Location	Behind operator seat
Fuel Tank Capacity	32.2 L (8.5 gal)
Fuel (Above 4°C [40°F])	Grade No. 2-D
Fuel (Below 4°C [40°F])	Grade No. 1-D
Fuel (All Temperatures - Above 1500 M [5000 ft])	Grade No. 1-D
Fuel Centane (Minimum)	45
Fuel Delivery	Mechanical fuel pump

Drive Train

Type	Hydrostatic
Drive Wheels	Front
Pump Drive	Flex coupler on engine flywheel-to-driven coupler on pump shaft
Travel Speed (Forward)	0-12.9 km/h (0-8.0 mph)
Travel Speed (Forward - Mowing)	0-6.4 km/h (0-4.0 mph)
Travel Speed (Reverse)	0-7.1 km/h (0-4.4 mph)

Hydraulics

Hydraulic Reservoir Oil Capacity	20.4 L (5.4 gal)
Hydraulic System Oil Capacity	28.8 L (7.6 gal)
Pump Type - 2500, 2500A	Triple gear
Pump Type - 2500E	Double gear
Pump Drive	Driven coupler from hydrostatic pump shaft
Systems	Mow (reel drive), lift, and steering
Cutting Unit Lift	Front and rear cylinder
Oil Cooler	Standard - all except "E" model
Mow/Backlap Valve - 2500 and 2500A	Electro-hydraulic
Mow/Backlap Function - 2500E	Electrically controlled
Lift Control Valve	Electro-hydraulic

SPECIFICATIONS AND INFORMATION SPECIFICATIONS

Steering

Type Power, hydraulic, rear wheel

Brakes

Main Braking Hydrostatic (dynamic)

Park Brake Dual disc

Park Brake Actuation Pedal

Cutting Units

Number of Cutting Units 3

Cutting Unit Drive - 2500 and 2500A Direct hydraulic motors

Cutting Unit Drive - 2500E 48V Electric with controllers

Reel Diameter 12.7 cm (5 in.)

Number of Blades (Standard) 11

Number of Blades (Optional) 7

Clip Frequency @ 6.4 km/h (4.0 mph) 4.44 mm (0.175 in.)

Front Rollers Optional - smooth or grooved

Bed Knife Adjustment Bed knife-to-reel

Height-of-Cut¹ 2.4-22 mm (3/32-7/8 in.)

Tires

Smooth - Front and Rear 18 x 10.50-10, 2 Ply

Smooth - Front and Rear 20 x 10.00-10, 2 Ply

Soft Trac - Front and Rear 20 x 10.00-10, 4-Ply

Weights and Dimensions

Weight

Machine (Gasoline Powered) 576 kg (1270 lb)

Machine (Diesel Powered) 626 kg (1380 lb)

Overall Width

Without Cutting Reels 1294.9 mm (51 in.)

With Cutting Reels 1694.8 mm (66.7 in.)

With Optional Grass Catchers 1847.9 mm (72.75 in.)

Overall Length

Without Cutting Reels 2272 mm (89.5 in.)

With Cutting Reels 2272 mm (89.5 in.)

With Optional Grass Catchers 2630 mm (103.5 in.)







Overall Height 1940.3 mm (76.5 in.)

1. Minimum 2 mm (0.080 in.) with ultra low cut tournament bedknife.

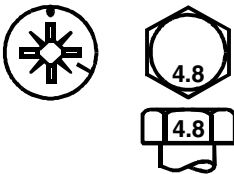
SPECIFICATIONS AND INFORMATION REPAIR INFORMATION

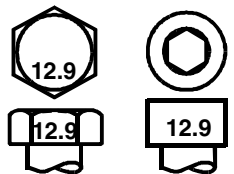
Repair Information

Metric Fastener Torque Values

Property Class and Head Markings				
Property Class and Nut Markings				

MIF (TS1163)

SIZE	Class 4.8				Class 8.8 or 9.8				Class 10.9				Class 12.9			
	Lubricated ¹		Dry ^a		Lubricated ^a		Dry ^a		Lubricated ^a		Dry ^a		Lubricated ^a		Dry ^a	
	N•m	lb-ft	N•m	lb-ft	N•m	lb-ft	N•m	lb-ft	N•m	lb-ft	N•m	lb-ft	N•m	lb-ft	N•m	lb-ft
M6	4.8	3.5	6	4.5	9	6.5	11	8.5	13	9.5	17	12	15	11.5	19	14.5
M8	12	8.5	15	11	22	16	28	20	32	24	40	30	37	28	47	35
M10	23	17	29	21	43	32	55	40	63	47	80	60	75	55	95	70
M12	40	29	50	37	75	55	95	70	110	80	140	105	130	95	165	120
M14	63	47	80	60	120	88	150	110	175	130	225	165	205	150	260	109
M16	100	73	125	92	190	140	240	175	275	200	350	225	320	240	400	300
M18	135	100	175	125	260	195	330	250	375	275	475	350	440	325	560	410
M20	190	140	240	180	375	275	475	350	530	400	675	500	625	460	800	580
M22	260	190	330	250	510	375	650	475	725	540	925	675	850	625	1075	800
M24	330	250	425	310	650	475	825	600	925	675	1150	850	1075	800	1350	1000
M27	490	360	625	450	950	700	1200	875	1350	1000	1700	1250	1600	1150	2000	1500
M30	675	490	850	625	1300	950	1650	1200	1850	1350	2300	1700	2150	1600	2700	2000
M33	900	675	1150	850	1750	1300	2200	1650	2500	1850	3150	2350	2900	2150	3700	2750
M36	1150	850	1450	1075	2250	1650	2850	2100	3200	2350	4050	3000	3750	2750	4750	3500

1. "Lubricated" means coated with a lubricant such as engine oil, or fasteners with phosphate and oil coatings. "Dry" means plain or zinc plated (yellow dichromate - Specification JDS117) without any lubrication.

DO NOT use these hand torque values if a different torque value or tightening procedure is given for a specific application. Torque values listed are for general use only and include a ±10% variance factor. Check tightness of fasteners periodically. DO NOT use air powered wrenches.

Shear bolts are designed to fail under predetermined loads. Always replace shear bolts with identical grade.

Fasteners should be replaced with the same class. Make sure fastener threads are clean and that you properly start

thread engagement. This will prevent them from failing when tightening.

When bolt and nut combination fasteners are used, torque values should be applied to the NUT instead of the bolt head.

Tighten toothed or serrated-type lock nuts to the full torque value.

Reference: JDS-G200.

SPECIFICATIONS AND INFORMATION REPAIR INFORMATION

Metric Fastener Torque Values - Grade 7

Size	Steel or Gray Iron Torque		Aluminum Torque	
	N•m	lb-ft	N•m	lb-ft
M6	11	8	8	6
M8	24	18	19	14
M10	52	38	41	30
M12	88	65	70	52
M14	138	102	111	82
M16	224	165	179	132

SPECIFICATIONS AND INFORMATION OILS & LUBRICANTS

Grease

IMPORTANT: Avoid damage! Use recommended John Deere greases to avoid component failure and premature wear.

The recommended John Deere greases are effective within an average air temperature range of -29° to 135° C (-20° to 275° F).

If operating outside that temperature range, contact your Servicing dealer for a special-use grease.

The following greases are preferred (this may change for high-speed applications such as cutting units):

- John Deere Multi-Purpose SD Polyurea Grease
- John Deere Multi-Purpose HD Lithium Complex Grease

If not using any of the preferred greases, be sure to use a general all-purpose grease with an NLGI grade No. 2 rating.

Wet or high-speed conditions may require use of a special-use grease. Contact your Servicing dealer for information.

Chassis And Roller Water Resistant Grease

This grease is specially formulated to prevent corrosion and water washout when used in a wet environment.

The following water resistant greases are **PREFERRED**:

- Special Purpose HD Water Resistant Grease - TY24425.
- Multi-Purpose HD Lithium Complex Grease - TY24416.

Other greases may be used if they meet or exceed the following specifications:

- John Deere Standard JDM J13A2, NLGI Grade 2.

IMPORTANT: Avoid damage! ONLY use quality grease in this application. DO NOT mix any other greases in this application. DO NOT use any BIO-GREASE in this application.

Alternative Lubricants

Conditions in certain geographical areas outside the United States and Canada may require different lubricant recommendations than the ones printed in this technical manual or the operator's manual. Consult with your John Deere Dealer, or Sales Branch, to obtain the alternative lubricant recommendations.

IMPORTANT: Avoid damage! Use of alternative lubricants could cause reduced life of the component.

If alternative lubricants are to be used, it is recommended that the factory fill be thoroughly removed before switching to any alternative lubricant.

Synthetic Lubricants

Synthetic lubricants may be used in John Deere equipment if they meet the applicable performance requirements (industry classification and/or military specification) as shown in this manual.

The recommended air temperature limits and service or lubricant change intervals should be maintained as shown in the operator's manual.

Avoid mixing different brands, grades, or types of oil. Oil manufacturers blend additives in their oils to meet certain specifications and performance requirements. Mixing different oils can interfere with the proper functioning of these additives and degrade lubricant performance.

Lubricant Storage

All machines operate at top efficiency only when clean lubricants are used. Use clean storage containers to handle all lubricants. Store them in an area protected from dust, moisture, and other contamination. Store drums on their sides. Make sure all containers are properly marked as to their contents. Dispose of all old, used containers and their contents properly.

Mixing of Lubricants

In general, avoid mixing different brands or types of lubricants. Manufacturers blend additives in their lubricants to meet certain specifications and performance requirements. Mixing different lubricants can interfere with the proper functioning of these additives and lubricant properties which will downgrade their intended specified performance.

SPECIFICATIONS AND INFORMATION COOLANT SPECIFICATIONS

Oil Filters

IMPORTANT: Avoid damage! Filtration of oils is critical to proper lubrication performance. Always change filters regularly.

The following John Deere oil filters are PREFERRED:

- AUTOMOTIVE AND LIGHT TRUCK ENGINE OIL FILTERS.

Most John Deere filters contain pressure relief and anti-drainback valves for better engine protection.

Other oil filters may be used if above recommended John Deere oil filters are not available, provided they meet the following specification:

- ASTB Tested In Accordance with SAE J806.

Coolant Specifications

Engine Coolant

The engine cooling system when filled with a proper dilution mixture of anti-freeze and deionized or distilled water provides year-round protection against corrosion, cylinder or liner pitting, and winter freeze protection down to -37°C (-34°F).

The following John Deere coolant is PREFERRED:

- **COOL-GARD™ PRE-DILUTED SUMMER COOLANT (TY16036).**

This coolant satisfies specifications for “Automobile and Light Duty Engine Service” and is safe for use in John Deere Lawn and Grounds Care/Golf and Turf Division equipment, including aluminum block gasoline engines and cooling systems.

The above preferred pre-diluted anti-freeze provides:

- Adequate heat transfer
- Corrosion-resistant chemicals for the cooling system
- Compatibility with cooling system hose and seal material
- Protection during extreme cold and extreme hot weather operations
- Chemically pure water for better service life
- Compliance with ASTM D4656 (JDM H24C2) specifications

If above preferred pre-diluted coolant is not available, the following John Deere concentrate is recommended:

- **COOL-GARD™ CONCENTRATED SUMMER COOLANT CONCENTRATE™ (TY16034).**

If either of above recommended engine coolants are not available use any Automobile and Light Duty Engine Service ethylene glycol base coolant, meeting the following specification:

- ASTM D4985 (JDM H24A2).

Read container label completely before using and follow instructions as stated.

SPECIFICATIONS AND INFORMATION COOLANT SPECIFICATIONS

IMPORTANT: Avoid damage! To prevent engine damage, DO NOT use pure anti-freeze or less than a 50% anti-freeze mixture in the cooling system. DO NOT mix or add any additives/conditioners to the cooling system in Lawn and Grounds Care/Golf and Turf Division equipment. Water used to dilute engine coolant concentrate must be of high quality - clean, clear, potable water (low in chloride and hardness - see table below) is generally acceptable. DO NOT use salt water. Deionized or distilled water is ideal to use. Coolant that is not mixed to these specified levels and water purity can cause excessive scale, sludge deposits, and increased corrosion potential.

Property	Requirements
Total Solids, Maximum	340 ppm (20 grns/gal)
Total Hardness, Maximum	170 ppm (10 grns/gal)
Chloride (as Cl), Maximum	40 ppm (2.5 grns/gal)
Sulfate (as SO ₄), Maximum	100 ppm (5.8 grns/gal)

Mix 50 percent anti-freeze concentrate with 50 percent distilled or deionized water. This mixture and the pre-diluted mixture (TY16036) will protect the cooling system down to -37°C (-34°F) and up to 108°C (226°F).

Certain geographical areas may require lower air temperature protection. See the label on your anti-freeze container or consult your John Deere dealer to obtain the latest information and recommendations.

Engine Coolant Drain Interval

When using John Deere Pre-Diluted (TY16036) Automobile and Light Duty Engine Service coolants, drain and flush the cooling system and refill with fresh coolant mixture every 36 months or 3,000 hours of operation, whichever comes first.

When using John Deere Concentrate (TY16034) Automobile and Light Duty Engine Service coolants, drain and flush the cooling system and refill with fresh coolant mixture every 24 months or 2,000 hours of operation, whichever comes first.

If above John Deere Automobile and Light Duty Engine Service coolants are not being used; drain, flush, and refill the cooling system according to instructions found on product container or in equipment operator's manual or technical manual.

SPECIFICATIONS AND INFORMATION IDENTIFICATION NUMBERS

Identification Numbers

Machine Identification Number Locations

When ordering parts or submitting a warranty claim, it is **IMPORTANT** that the machine product identification number and component serial number are included.

The location of the machine identification number and component serial numbers are shown.

Machine Identification Number

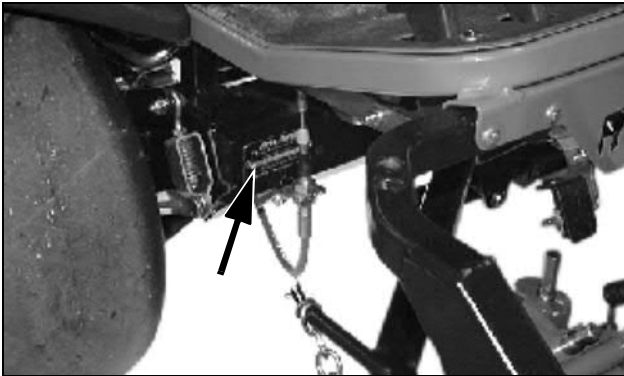

M84560

Gasoline Engine Serial Number

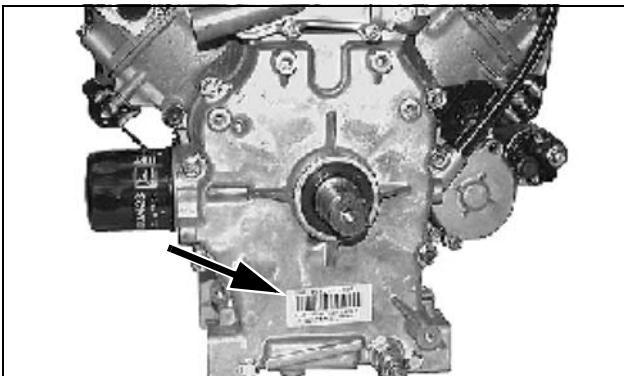

M84561

Diesel Engine Serial Number

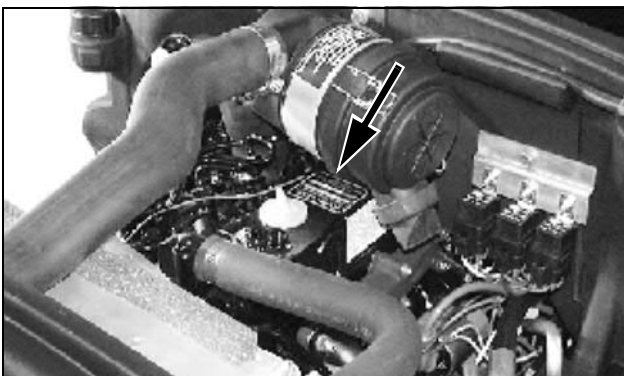

M84562

Hydrostatic Pump Serial Number

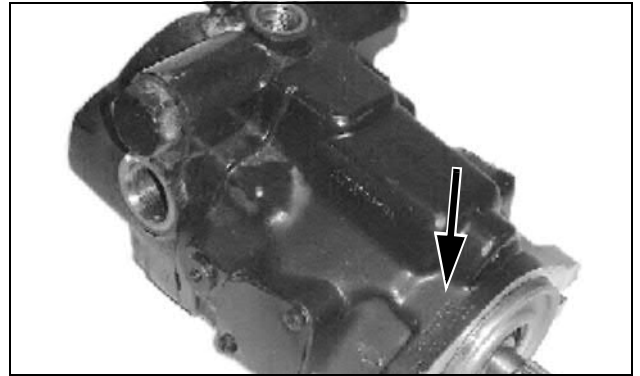

M84786

Cutting Unit Serial Number

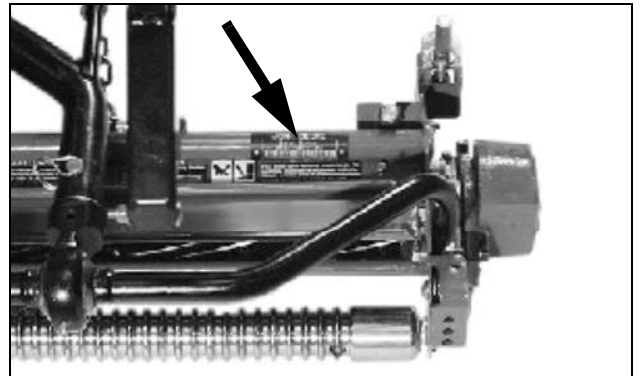

M84563

SPECIFICATIONS AND INFORMATION OPERATIONAL CHECKOUT

Operational Checkout

Interlock System Operation

It is important to understand the interlock system and how it works. Before performing the checkout procedures, become familiar with the interlock system so that an interlock function will not be mistaken for a machine problem.

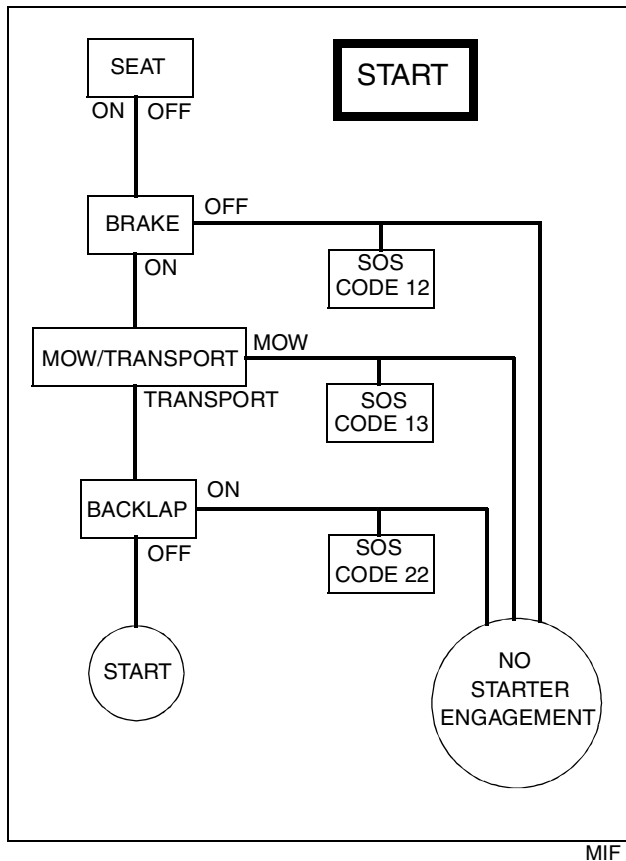

For the starting motor to engage and the engine to run, the following conditions must be met simultaneously:

- Operator on seat and/or park brake engaged.
- Mow/transport lever/pedals in the TRANSPORT position.
- Mow/backlap valve in MOW position.

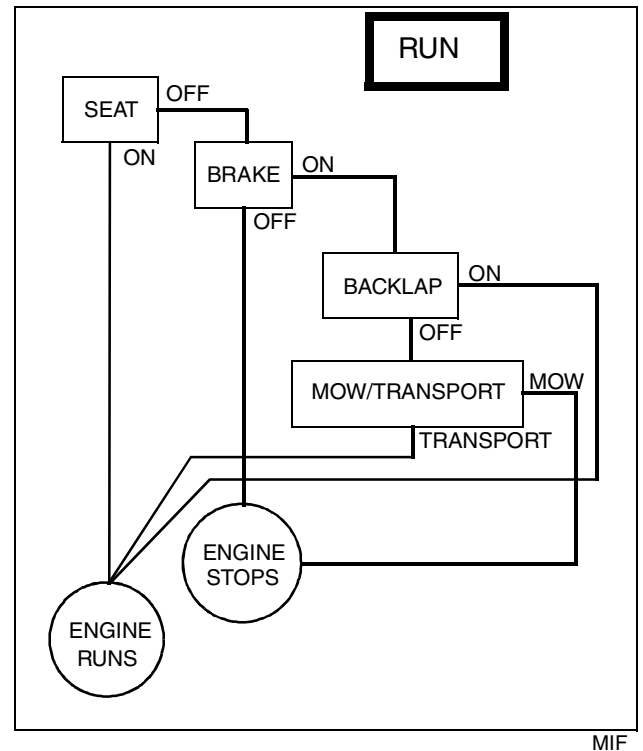

For the engine to run, the following condition must be met:

- Operator must be on the seat or the park brake must be engaged.

If the mow/transport lever is in the TRANSPORT position with the park brake not engaged and the operator rises off the seat, the engine will stop.

If the mow/transport lever is in the MOW position with the park brake engaged and the operator rises off the seat, the engine will stop.

If the operator is mowing and rises off the seat, the cutting reels and engine will stop.

In order to mow, the following conditions must be met:

- Operator in the operator seat.
- Throttle lever moved to the FAST position.
- Mow/transport lever in the MOW position.
- Cutting units lowered to the ground.
- Parking brake not engaged.
- Backlap valve not engaged.

If the operator is mowing and the park brake is depressed, the cutting reels will stop rotating.

If the operator is mowing and engages the backlapping valve while on the operator seat, the cutting reels will stop rotating.

If the operator attempts to backlap the cutting units with the operator seat occupied, the cutting reels will not rotate.

SPECIFICATIONS AND INFORMATION OPERATIONAL CHECKOUT

If the operator is backlapping the cutting units with the operator seat not occupied and the park brake is disengaged, the engine will stop.

General Information

The procedures covered in this group are used to give a quick checkout of all the systems and components on the unit. These checkouts should be run to insure proper operation after any extended storage, when the unit comes in for service and after repairs have been made on the unit. They can also be helpful in determining the value of the unit at trade-in time. The unit should be placed on a level surface to run checkout. All checkouts should be done and all the steps of each checkout should be followed.

Checkout List

- Conditions - How the unit should be set up for the checkout.
- Procedure - The specific action to be done.
- Normal - What should happen, or be heard, or seen.
- If Not Normal - Where to go if other tests or adjustments are needed.

When performing the checkout, be sure to set your machine up to the test conditions listed and follow the sequence carefully. The "NORMAL" paragraph gives the result that should happen when performing the checkout. If the results are not normal, follow the instructions listed in the "IF NOT NORMAL" paragraph to determine the cause and repair the malfunction.

Diesel Engine Air Filter Restriction Indicator Check

Conditions

- Engine stopped.
- Machine parked on a level surface.
- Cutting units lowered to the ground.
- Mow/transport lever in "TRANSPORT" position.
- Key switch in "STOP" position.
- Park brake engaged.

Procedure

1. Raise cowl.
2. Inspect the housing for cracks or other damage.

NOTE: Indicator will not provide an accurate indication if the housing is cracked or broken.

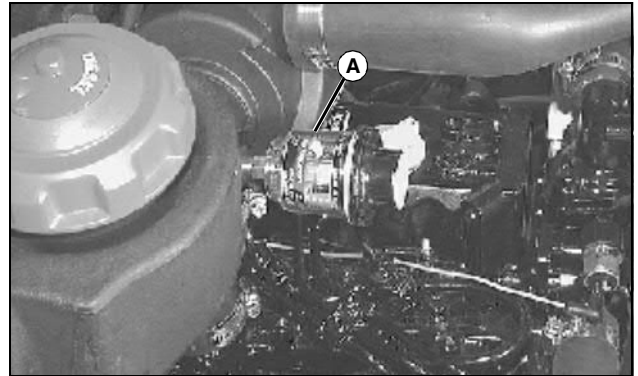

M84632

3. Check the position of the plunger in the air filter restriction indicator (A).

Normal

- The housing should be free of cracks or other damage.
- The plunger should be in the green area of the indicator.

If Not Normal

- If the housing is cracked or damaged, replace the indicator. (See "Remove and Install Air Filter Restriction Indicator" on page 175.)
- If plunger is in the red area of the indicator, service the air cleaner filter elements. (See "Remove and Install Air Cleaner Assembly" on page 176.)

Hydraulic Reservoir Oil Level Check

Condition

- Engine stopped.
- Machine parked on a level surface.
- Cutting units lowered to the ground.
- Mow/transport lever in the "TRANSPORT" position.
- Key switch in the "STOP" position.
- Hydraulic oil cold.
- Park brake engaged.

SPECIFICATIONS AND INFORMATION OPERATIONAL CHECKOUT

Procedure

1. Raise cowling.

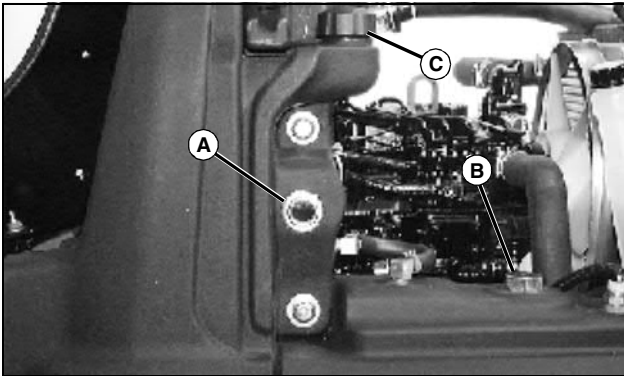

M84568

2. Check oil level at sight glass (A).
3. Inspect oil for signs of contamination or foaming.

Normal

- Oil level should be at the center of the sight glass.

IMPORTANT: Avoid damage! Oil should be clear, not white, yellow, or cloudy.

- Oil should show no signs of foaming or contamination.

If Not Normal

NOTE: If the main hydraulic reservoir oil level is low, fill reservoir at the reservoir filler cap. Oil added at the expansion tank will not transfer to the reservoir quickly, resulting in an inaccurate reading.

- If oil level is below the sight glass, remove the main hydraulic reservoir filler cap (B), and if needed add hydraulic oil until main reservoir is full, then replace filler cap. Remove expansion tank filler cap (C) and add oil to expansion tank until oil level is at center of the sight glass. (See "Hydrostatic Transmission and Hydraulic Oil" on page 20.)
- If the oil level is low, check hydraulic hoses and connections for leaks. Repair as needed.
- If oil shows signs of foaming or contamination, drain hydraulic reservoir, replace oil filter and refill reservoir with clean hydraulic oil.

Hydraulic Oil Filter Restriction Indicator Check

Condition

- Machine parked on a level surface.
- Cutting units lowered to the ground.
- Park brake engaged.
- Key switch in "STOP" position.
- Mow/transport lever in "TRANSPORT" position.
- Operator off of seat.

Procedure

1. Raise and lock seat platform.
2. Start engine and run at Fast Idle.

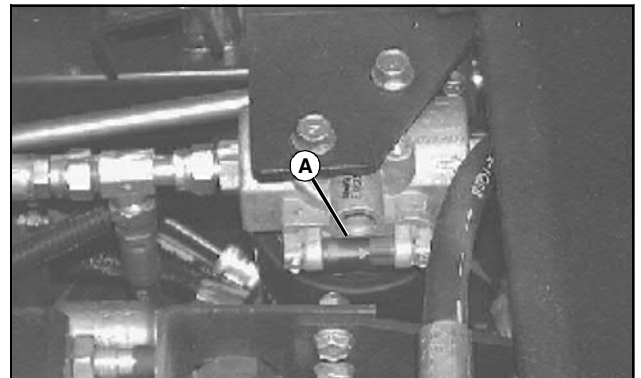

M84631

3. Check the position of the plunger in the hydraulic oil filter restriction indicator (A).

Normal

- The plunger should not be within the red area of the indicator.

If Not Normal

- Replace the oil filter.

SPECIFICATIONS AND INFORMATION OPERATIONAL CHECKOUT

Start Circuit Check

Conditions

- Operator on seat.
- Mow/transport lever in TRANSPORT position.
- Park brake engaged.
- Mow/backlap valve in MOW position.

Procedure

1. Turn key switch to START position.

Normal

- The engine should crank and start.

If Not Normal

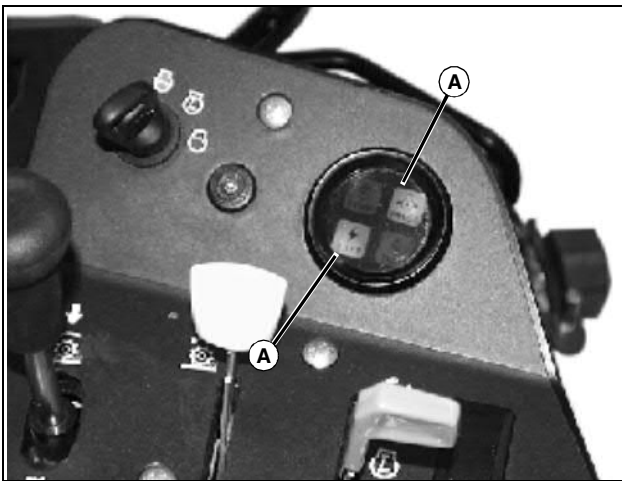

M84737

If the engine does not crank, the oil pressure light (A) should remain lit and the battery discharge light (B) will begin to flash, indicating one of the following codes:

NOTE: The code will cycle continuously with a two second pause between display cycles.

Only one code can be displayed at a time. Repeat check procedure after repairs have been completed.

- One pulse followed by a short pause, followed by two pulses (Code 1-2); Indicates that the park brake switch is not activated. Engage park brake and repeat check procedure.
- One pulse followed by a short pause, followed by three pulses (Code 1-3); Indicates that the mow switch is activated. Move mow/transport lever to TRANSPORT position and repeat check procedure.
- Two pulses followed by a short pause, followed by two pulses (Code 2-2); Indicates that the mow/backlap valve is in BACKLAP position. Move mow/backlap valve to MOW position and repeat check procedure.

- If there is no response to the key switch and no codes indicated as described above, proceed to the ELECTRONIC CONTROL MODULE CHECK.

Electronic Control Module Check

Reason

To determine the operating condition of the electronic control module. The electronic control module includes several self-protection features and is designed to last the life of the machine. Most electrical problems are caused by harness or component failures, and are rarely a result of a control module failure.

Procedure

1. Park machine on level surface.
2. Lower cutting units to the ground.
3. Turn key switch to STOP position.
4. Engage park brake.
5. Raise and latch seat platform.
6. Move key switch to RUN position.

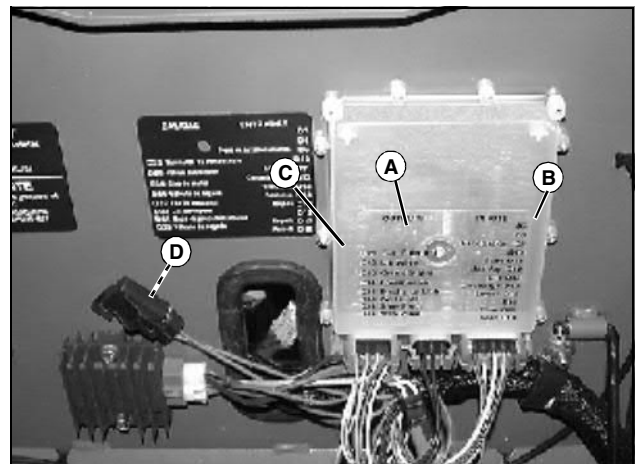

M84736

7. Check "Heartbeat" light (A) and input/output indicator lights (B and C).

Results

Normal

- "Heartbeat" light flashing in a regular, even rate.
- Input indicator light(s) corresponding to activated switch(es) lit.
- Output indicator light(s) corresponding to active component(s) lit.



Suggest:

If the above button click is invalid.

Please download this document first, and then click the above link to download the complete manual.

Thank you so much for reading

SPECIFICATIONS AND INFORMATION OPERATIONAL CHECKOUT

If Not Normal

- If the “Heartbeat” light and input/output indicator lights are not lit, check F2 main fuse (D). If fuse is good, check current supply to the control module. For gasoline engine models; (See “Power Circuit Diagnosis - Switched” on page 315.)

For diesel engine models; (See “Power Circuit Diagnosis - Switched” on page 431.)

NOTE: The code will cycle continuously with a two second pause between display cycles.

Only one code can be displayed at a time. Repeat check procedure after repairs have been completed.

- The “Heartbeat” light may flash one of the following codes:
 - Three pulses followed by a short pause, followed by another pulse (Code 3-1); Indicates an over-voltage condition (voltage input to control box over 18 volts). For gasoline engine models; (See “Charging Circuit Diagnosis” on page 347.) For diesel engine models; (See “Charging Circuit Diagnosis” on page 463.)

NOTE: When the following codes are displayed, no output indicator lights will be lit.

Circuits connected to the “Output” connector of the control module, operate by switching the ground side of the circuit.

- Three pulses followed by a short pause, followed by two pulses (Code 3-2); Indicates a wiring harness failure. Proceed to Test Control Module procedure.
- Three pulses followed by a short pause, followed by three pulses (Code 3-3); Indicates an output short to positive 12 volt condition on the components of one (or more) of the following circuits:

NOTE: See individual circuit diagnosis in Electrical section for diagnostic procedures.

- Lift/Lower Valve Circuit
- Crank Engine Circuit
- Discharge Light Circuit
- Glow Plug Circuit (Diesel)
- Mow Valve Circuit
- Three pulses followed by a short pause, followed by four pulses (Code 3-4); Indicates a fuel solenoid circuit failure. For gasoline engine models; (See “Run Circuit Diagnosis” on page 339.) For diesel engine models; (See “Run Circuit Diagnosis” on page 454.)
- Three pulses followed by a short pause, followed by five pulses (Code 3-5); Indicates fuel hold internal checking failure on circuit board, or output miswired to +12 volts.

- Three pulses followed by a short pause, followed by six pulses (Code 3-6); Indicates a faulty power or ground connection to the control board.
- Three pulses followed by a short pause, followed by seven pulses (Code 3-7); Indicates a faulty power or ground connection to the control board.
- Three pulses followed by a short pause, followed by eight pulses (Code 3-8); Indicates a faulty power or ground connection to the control board.

Test Control Module

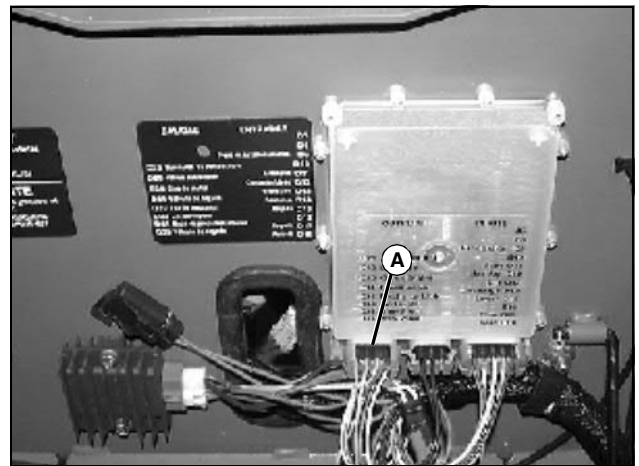

M84736

1. Move key switch to STOP position.
2. Disconnect “Output” connector (A) from control box.
3. Move key switch to RUN position.

Normal

- “Heartbeat” light flashing in a regular, even rate. This indicates the control module is operating properly and the problem is in the wiring harness.

If Not Normal

- If the “Heartbeat” light continues to flash the 3-2 code, replace the control module.

<https://www.ebooklibonline.com>

Hello dear friend!

Thank you very much for reading.

Enter the link into your browser.

The full manual is available for immediate download.

<https://www.ebooklibonline.com>