

2155 TRACTOR



JOHN DEERE

OPERATORS MANUAL

2155
TRACTOR

OML57718 B7 English

JOHN DEERE WERKE MANNHEIM
OML57718 B7

LITHO IN THE U.S.A.
ENGLISH





INSPECTIONS

We appreciate the confidence you have shown in John Deere and your John Deere dealer for the purchase of this equipment.

We want you to have the best performance from your new machine. To accomplish this, your dealer will perform a Predelivery Inspection and will familiarize you with the proper and safe operation of this machine.

After the machine has operated the first 100 hours, you should contact your dealer and arrange an appropriate date at which the After-Sale Inspection will be performed. It will be performed most effectively in the workshop of your dealer.

IMPORTANT WARRANTY INFORMATION

The warranty on this tractor appears on your copy of the purchase order which you should have received from your dealer when making your purchase. This warranty provides you the assurance that John Deere will back its products where defects appear within the warranty period. In some circumstances, John Deere also provides field improvements, often without charge to the customer, even if the product is out of warranty.

Warranty and field improvements are a part of John Deere's product support program for customers who operate and maintain their equipment as described in this manual. Should the equipment be abused, or modified to change its performance beyond the original factory specifications, the warranty will become void and field improvements may be denied. Setting fuel delivery beyond specifications or otherwise overpowering machines will result in such action.

The tire manufacturer's warranty supplied with your machine may not apply outside the U.S.A. and Canada.

© Deere & Co., European Office,
D-6800 Mannheim

SAFETY



CAUTION: This safety alert symbol indicates important safety messages in this manual. When you see this symbol, be alert to the possibility of personal injury and carefully read the message that follows.

IMPORTANT: This machine is designed and manufactured according to JOHN DEERE specifications. To avoid accidents and to assure optimum performance, the machine must not be modified or altered in any way not approved by JOHN DEERE, nor must it be used under any conditions or for any purpose for which it has not been designed.

To assure safe operation of this machine, read the Safety Rules on the first pages of this manual.

MEASUREMENTS

Your operator's manual contains the international standardized SI metric measurement system.

DIRECTION

Right-hand and left-hand sides of this machine are determined by facing in the direction of forward travel.

PRODUCT IDENTIFICATION NUMBERS

Record the identification number(s) in the spaces provided following Specifications. Accurately record all of the characters because (should the product be stolen) tracing is sometimes through a computer match of letters and numbers. Also, your dealer needs this information when ordering parts. If you carry your operators manual on the machine for reference, be sure to also record the identification number(s) on a separate sheet of paper in a secure place not on the machine so you will still have a record in case the machine is stolen.

All information, illustrations, and specifications contained in this operator's manual are based on the latest information available at the time of publication. The right is reserved to make changes at any time without notice.

Identification View



L112961

L112961-2155ALE-011286

<https://www.ebooklibonline.com>

Hello dear friend!

Thank you very much for reading.

Enter the link into your browser.

The full manual is available for immediate download.

<https://www.ebooklibonline.com>

Contents

Safety	05-	Operator's Station	30-
– Safety	05-1	– Lighting system	30-1
		– Roll guard	30-2
		– Seats	30-3
Controls and Instruments	10-		
– Controls	10-1		
– Instrument cluster	10-2		
Break-In Period	15-	Treads, Tires, Ballast	35-
– After the first 4 and 8 hours	15-1	Wheel treads	35-1
– After the first 50 hours	15-2	– Adjusting front wheel tread	35-2
– After the first 100 hours	15-3	– Checking front wheel toe-in	35-2
– Within the first 100 hours	15-3	– Adjusting front wheel toe-in	35-3
		– Rear wheel tread adjustment	35-4
		Tires	35-7
		– Tire pressures	35-7
		– Servicing tires	35-7
		– Use correct tire combinations	35-8
Operating the Engine	20-	Ballast	35-8
– Prestarting check	20-1	– Measuring rear wheel slip	35-9
– Starting the engine	20-2	– Rear wheel weights	35-9
– Electric starting aid	20-3	– Installing rear wheel weights	35-10
– Ether starting aid	20-4	– Filling tires with liquid ballast	35-11
– Starting with a booster battery	20-5	– Front weights	35-12
– Towing the tractor to start	20-6		
– Towing the tractor	20-6	Rockshaft, Three-Point Hitch	40-
– Parking the tractor	20-7	Rockshaft	40-1
– Stopping the engine	20-7	– Control lever	40-1
		– Load selector lever	40-2
Operating the Tractor	25-	– Rate-of-implement drop	40-3
Reduce fuel consumption	25-1	Three-point hitch	40-4
Ground travel speeds	25-3	– Draft links	40-4
– At desired engine speed	25-3	– Center link	40-4
– At rated engine speed	25-4	– Lift links	40-5
– Shifting transmission	25-5	– Attaching implements	40-6
– Hi-Lo shift unit	25-6	– Positioning sway blocks	40-7
– Reverser transmission	25-6		
– Differential lock	25-7	Accessories	45-
– Foot brakes	25-7	Selective control valves	45-1
		– Poppet type valves	45-1
		– Breakaway couplers	45-3
		– Spool type valves	45-5
		– Quick couplers	45-5
		– Maximum permissible oil withdrawal	45-6
		Double acting remote hydraulic cylinder	45-7
		Swinging drawbar	45-8

Contents

Power Take-Off	50-	Service-Clutch	85-
– PTO guard	50-1	– Adjusting clutch	85-1
– Operation of PTO	50-2	– Lubricating clutch throw-out bearing	85-2
– Attaching PTO driven equipment	50-3		
		Service-Engine	90-
Fuel, Lubricants, Coolant	60-	– Engine oil	90-1
Fuel	60-1	– Engine filter	90-2
– Fuel specifications	60-1	– Alternator V-belt	90-2
– Fuel storage	60-1	– Engine speeds	90-2
Lubricants	60-2		
– Engine oil	60-2	Service-Cooling System	95-
– Transmission/hydraulic oil	60-3	– Checking coolant level	95-1
– Extreme pressure grease	60-4	– Replacing coolant	95-2
– Engine coolant	60-5		
		Service-Axles and Wheels	100-
Removing Access Covers	65-	– Lubricating front axle	100-1
– Hood	65-1	– Lubricating rear axles	100-1
– Grille screens	65-1		
– Battery box covers	65-1	Service-Fuel System	105-
		– Checking fuel filter	105-1
Lubrication and Periodic Service	70-	– Replacing fuel filter	105-2
– Service intervals	70-1	– Bleeding fuel system	105-3
– Time-table	70-2		
		Service-Transmission/Hydraulics	110-
Service-Air Intake System	75-	– Checking oil level	110-1
– Primary air filter	75-1	– Replacing filter element	110-2
– Secondary air filter	75-3	– Changing oil	110-3
– Dust unloading valve	75-4		
– Air intake hoses	75-4	Service-Miscellaneous	115-
		– Operator's seat	115-1
Service-Brakes	80-	– 3-Point hitch	115-1
– Bleeding brakes	80-1		
– Adjusting hand brake	80-1		

Contents

Service-Electrical System	120-	Specifications	140-
- Batteries	120-1	- Engine	140-1
- Checking specific gravity	120-2	- Weights	140-2
- Level of electrolyte	120-3	- Electrical system	140-2
- Neutral start system	120-4	- Capacities	140-3
- Starting motor	120-4		
- Removing batteries	120-5	Identification Numbers	145-
- Alternator	120-6	- Identification numbers	145-1
- Lamps	120-7		
- Fuses	120-8	Lubrication and Maintenance Records	150-
		- Lubrication and maintenance records	150-1
Tractor Storage	125-		
- Storage	125-1	Attachments	155-
- Removing tractor from storage	125-2	- Attachments	155-1
Crime Prevention Tips	130-	Index	160-
- Crime prevention tips	130-1	- Index	160-1
Troubleshooting	135-		
- Hydraulic system	135-1		
- Engine	135-2		
- Electrical system	135-3		

Safety

READ SAFETY SIGNS

Carefully read and follow all CAUTION, WARNING, and DANGER safety signs. Keep safety signs in good condition. Replace missing or damaged safety signs.

The sign shown here is located on the left hand fender.



CAUTION

1. Before operating this tractor, read the Operator's Manual for complete instructions and safety information.
2. Keep all shields in place.
3. Hitch towed loads only to drawbar to avoid rearward upset.
4. Make certain everyone is clear of machine before starting engine or operation.
5. Keep all riders off tractor and equipment.
6. Keep hands, feet and clothing away from power-driven parts.
7. Reduce speed when turning or applying individual brakes or operating around hazards, on rough ground or steep slopes.
8. Couple brake pedals together for road travel.
9. Use flashing warning lights on highway unless prohibited by law.
10. Stop engine, lower implement to ground and shift to "PARK" or set brake(s) securely before dismounting. Wait for all movement to stop before servicing machinery.
11. Remove key if leaving tractor unattended.

L110 241

L110241-2150ALE-150985

SAFETY SIGN "TRACTOR RUNAWAY"

This sign is located near the starting motor.



WARNING

Avoid possible injury or death from a machine runaway.

1. Do not start engine by shorting across starter terminals. Machine will start in gear and move if normal starting circuitry is bypassed.
2. Start engine only from operator's seat with transmission in neutral or park. NEVER start engine while standing on ground.

L110 242

L110242-2950ALE-150585

SAFETY SIGN "ROLL-GARD"

This sign is located on the left hand post.



CAUTION

Use of seat belt with this Roll-Gard is recommended for almost all operating conditions.

L110243

L110243-2755ALE-011186

SAFETY SIGN "PTO"

This sign is located on the PTO master shield.



WARNING

TO AVOID BODILY INJURY:

1. Keep PTO master shield and all power drive system safety shields in place. Also install PTO shaft guard when the system is not in use.
2. When operating PTO driven implements, install drawbar in the down position if offset, and use the following drawbar instructions:

PTO Shaft	PTO Shaft End to Hitch Pin Hole
540 rpm - 6 spline	14.00 in. (356 mm)
1000 rpm - 21 spline	16.00 in. (407 mm)
*1000 rpm - 20 spline	20.00 in. (508 mm)

*1.75 in. (44.5 mm) dia. shaft

L110244

L110244-2955ALE-011086

SAFETY SIGN "BATTERY"

This sign is located on top of batteries.

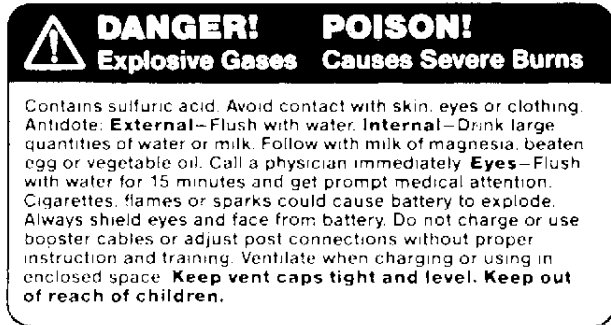

⚠ DANGER! POISON!
Explosive Gases Causes Severe Burns

Contains sulfuric acid. Avoid contact with skin, eyes or clothing. Antidote: **External**—Flush with water. **Internal**—Drink large quantities of water or milk. Follow with milk of magnesia, beaten egg or vegetable oil. Call a physician immediately. **Eyes**—Flush with water for 15 minutes and get prompt medical attention. Cigarettes, flames or sparks could cause battery to explode. Always shield eyes and face from battery. Do not charge or use booster cables or adjust post connections without proper instruction and training. Ventilate when charging or using in enclosed space. **Keep vent caps tight and level. Keep out of reach of children.**

L110 245

L110245-2950ALE-150585

LEARN MACHINE SAFETY

Carefully read this manual. Learn how to operate the machine and how to use the controls properly.

Do not let anyone operate this machine without proper instruction.

Unauthorized modifications to the machine may impair the function and/or safety and affect machine life.

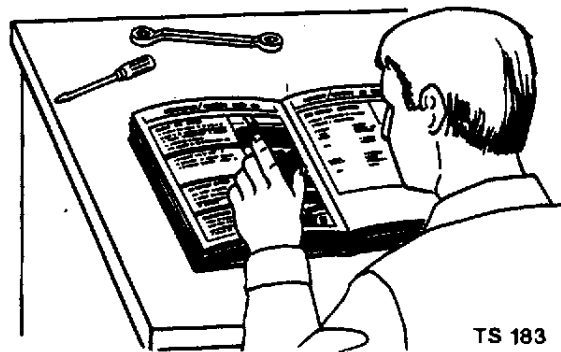

AB6-TS183 053-READ2 080785

LEARN SAFETY SIGNAL WORDS

Signal words CAUTION, WARNING, and DANGER are used with the safety-alert symbol to draw attention to potentially unsafe areas. Learn these signal words.

CAUTION is used with all safety messages in this manual and is used on the machine to identify some of the less serious hazards.

WARNING is used on the machine to let the operator know that a greater risk is involved for a specific potential hazard.

DANGER is used on the machine to mean that one of the most serious potential hazards is present. Unsafe operating techniques or bad work habits in this area could lead to personal injury or death.

Red and white are colors used with the word danger. Black and yellow are found on signs carrying the words caution, be careful, or warning.



T 81389

AB6-T81389 053-SIGNAL 220785

PREVENT TRACTOR RUNAWAY

Avoid possible injury or death from a machine runaway.

Do not start engine by shorting across starting motor terminals. Machine will start in gear if normal starting circuitry is bypassed.

NEVER start engine while standing on the ground. Start engine only from operator's seat with transmission in neutral.



L110 247

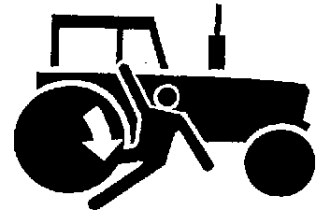

L110247-2950ALE-150585

STAY CLEAR OF MOVING TRACTOR

Be sure everyone is clear of tractor and attached equipment before starting engine. Some movement may occur as engine starts.

Never try to get on or off a moving tractor.

Before dismounting, place the transmission in neutral (A), apply hand brake (B) and lower implements to the ground. If tractor is to be left unattended, stop the engine and remove the key.

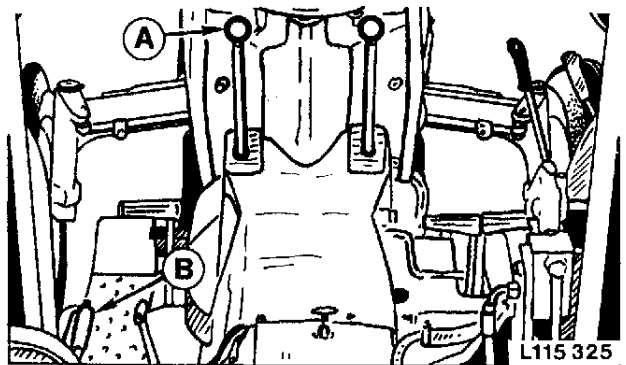

L115 325

Never attempt to start or operate tractor except from operator's station.

L115325-2155ALE-011286

OPERATING THE ENGINE

Before starting the engine make sure there is plenty of ventilation. Never operate the engine in a closed building. Danger of asphyxiation!

When starting the engine, rockshaft control lever must be in "lower" position.

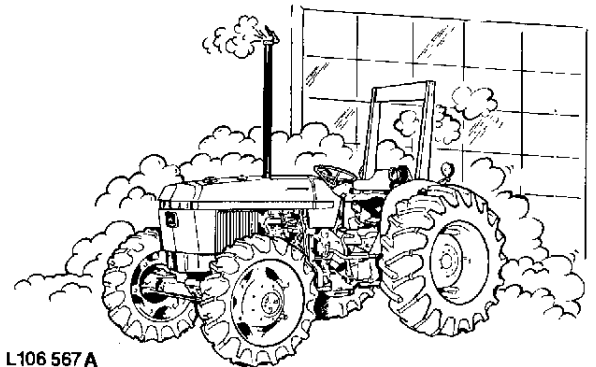

L106 567 A

L106567A-2155ALE-011286

OPERATE TRACTOR SAFELY

Slow down for hillsides, rough ground, and sharp turns.

Couple the brake pedals together before driving at transport speeds.

When implements or attachments are used with the tractor, always follow safety precautions listed in implement operator's manual or operating instructions. When raising a heavy object with a loader, be sure the object is secure from falling. It could fall on and seriously injure a bystander or the operator.

Keep all shields in place.

Always apply hand brake before dismounting. Leaving transmission in gear with engine stopped will NOT prevent tractor from moving.

OPEOM-2950ALE-150585

USE CAUTION ON HILLSIDES

Avoid holes, ditches, and obstructions which may cause the tractor to tip – especially on hillsides.

Never drive near the edge of a gully or steep embankment – it might cave in.

Driving forward out of a ditch or mired condition or up a steep slope could cause tractor to tip over rearward. Back out of these situations if possible.

Be especially careful when using single wheels. Danger of overturn increases greatly with narrow 1.50 m (60 in.) tread at high speed.

Hitch towed loads only to drawbar. When using a chain, take up the slack slowly.

SAFOM-2155ALE-011288

BALLAST TRACTOR CORRECTLY

Steering and braking performance of the tractor can be considerably affected by attaching implements. To maintain the necessary tractor ground contact, ballast tractor as necessary.

Braking performance: On tractors equipped with a front loader, ballast rear end of tractor (rear wheel weights, filling rear tires with liquid ballast or attaching a rear mounted implement).

When driving the tractor with front loader installed and without rear implement, never drive tractor faster than 20 km/h (12.5 mph).

Steering performance: On tractors equipped with heavy rear-mounted implement, install sufficient front ballast (front weights).

BALOM-2950ALE-150585

SHIFT TO LOW GEAR ON HILLS

Before descending a steep hill, shift to a low gear to control the tractor with little or no braking. Never coast downhill.

When transporting downhill on icy or graveled grades, be alert for skids which could result in loss of steering control. To decrease chance of skids, reduce speed and be sure tractor is properly ballasted.

Additional ballast may be needed for transporting heavy integral implements. When implement is raised, drive slowly over rough ground, regardless of how much ballast is used.

SAFOM-2155BLE-011286

KEEP RIDERS OFF MACHINE

Only allow the operator on the machine. Keep riders off.

Riders on a machine are subject to injury such as being struck by foreign objects and being thrown off of the machine. Riders also obstruct the operator's view resulting in the machine being operated in an unsafe manner.



L110 229

L110229-2950ALE-150585

SAFETY ON PUBLIC ROADS

Always comply with local traffic regulations when driving on public roads.

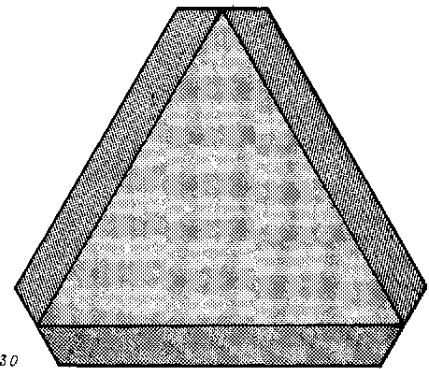

H28930

H28930-2950ALE-150585

MAKE TRACTOR VISIBLE ON HIGHWAY

Turn light switch to "H" position. Never use white lights which are visible from the rear. Always dim headlights before meeting another vehicle. Keep headlights properly adjusted.

Add reflectors, and auxiliary lighting to equipment as required for safety and by local regulations.

Before operating tractor on highway, be sure flashing warning lamps (A) work properly. Adjust rear view mirror (B), and clean windows.

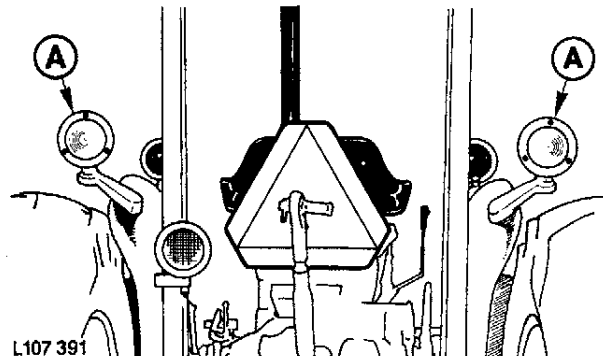

L107 391

L107391-2150ALE-150585

USE A SAFETY CHAIN

A safety chain will help control drawn equipment (B) should it accidentally separate from the drawbar (A) while transporting. Using the appropriate adapter parts, attach chain to tractor drawbar support or other specified anchor location. Provide only enough slack in the chain to permit turning. See your JOHN DEERE dealer for a chain with a strength rating equal to or greater than the gross weight of the towed machine.

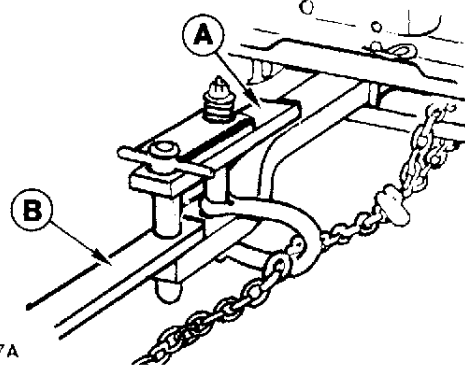

L107407A

L107407A-2950ALE-150585

HANDLE FUEL SAFELY – AVOID FIRES

Handle fuel with care: it is highly flammable. Do not refuel the machine while smoking or when near open flame or sparks.

Always stop engine before refueling machine. Fill fuel tank outdoors.

Prevent fires by keeping machine clean of accumulated trash, grease, and debris. Always clean up spilled fuel.

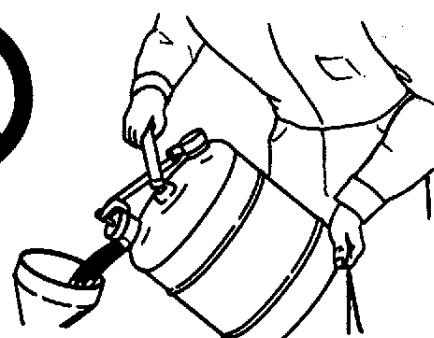

TS 185

AB6-TS185 053-FIRE1 240785

PREPARE FOR EMERGENCIES

Be prepared if a fire starts.

Keep a first aid kit and fire extinguishers handy.

Keep emergency numbers for doctors, ambulance service, hospital, and fire department near your telephone.

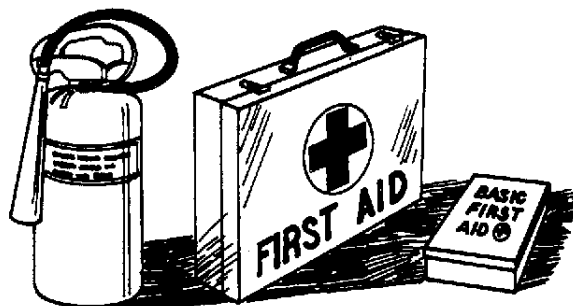

TS 186

AB6-TS186 053-FIRE2 080785

HANDLE STARTING FLUID SAFELY

Starting fluid is highly flammable.

Keep all sparks and flame away when using it. To prevent accidental discharge when storing the pressurized can, keep the cap on the container, and store in a cool, protected location.

Do not incinerate or puncture a starting fluid container.



TS 6089A

AB6-T6089A U 053-FIRE3 080785

TRANSPORT TRACTOR SAFELY

The best method for transporting a disabled tractor is to haul it on a flatbed carrier.

If towing a tractor, never tow faster than 10 mph (15 km/h). Have an operator steer and brake tractor.

U01-HAUL IT 090585

TOW EQUIPMENT PROPERLY

Use caution when towing loads at transport speeds. Reduce speed if towed load weighs more than the tractor and is not equipped with brakes. Avoid hard braking applications. Consult implement operator's manual for recommended transport speeds.

Use additional caution when transporting towed loads under adverse surface conditions, when turning or on inclines.

Safety-2950ALE-020884

PREVENT BATTERY EXPLOSIONS

Battery gas can explode. Keep sparks and flames away from batteries. Use a flashlight to check battery electrolyte level.

Never check battery charge by placing a metal object across the posts. Use a voltmeter or hydrometer.

Always remove grounded (-) battery clamp first and replace it last.

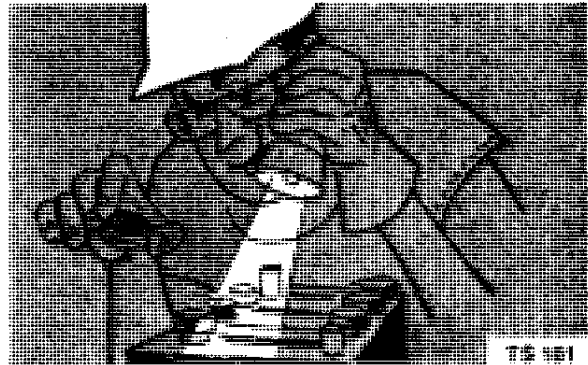

TS181-2755ALE-011186

AVOID ACID BURNS

Sulfuric acid in battery electrolyte is poisonous. It is strong enough to burn skin, eat holes in clothing, and cause blindness if splashed into eyes.

Avoid the hazard by:

1. Filling batteries in a well-ventilated area.
2. Wearing eye protection and rubber gloves.
3. Avoiding breathing fumes when electrolyte is added.
4. Avoiding spilling or dripping electrolyte.

If you spill acid on yourself:

1. Flush your skin with water.
2. Apply baking soda or lime to help neutralize the acid.
3. Flush your eyes with water for 10-15 minutes. Get medical attention immediately.

If acid is swallowed:

1. Drink large amounts of water or milk.
2. Then drink milk of magnesia, beaten eggs, or vegetable oil.
3. Get medical attention immediately.

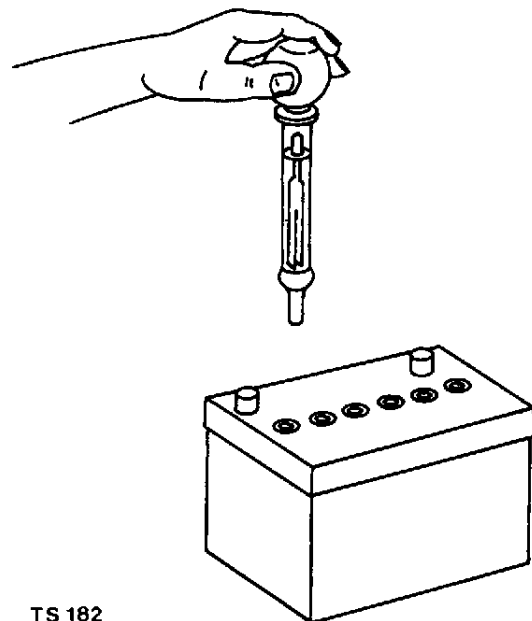

TS 182

AB6-TS182 053-ACID 180485

NOISE PROTECTION

Prolonged exposure to loud noise can cause impairment or loss of hearing.

Wear a suitable hearing protective device such as earmuffs (A) or earplugs (B) to protect against objectionable or uncomfortable loud noises.

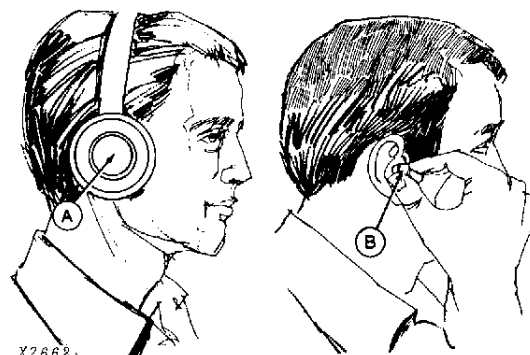

X7662

X7662-1065AZE-262081

USE SEAT BELT PROPERLY

Use a seat belt when you operate with a roll-over protective structure (ROPS) to minimize chance of injury from an accident such as an overturn.

Do not use a seat belt if operating without a ROPS.

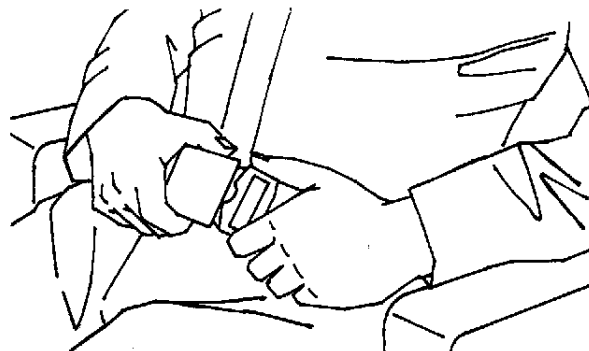

RW4419-2950ALE-150585

HANDLE CHEMICALS PROPERLY

Follow instructions given in implement operator's manual and those given by the chemical manufacturer when using agricultural chemicals.

SAFOM-2150ALE-080984

WEAR PROTECTIVE CLOTHING

Wear fairly tight clothing..... and safety equipment.

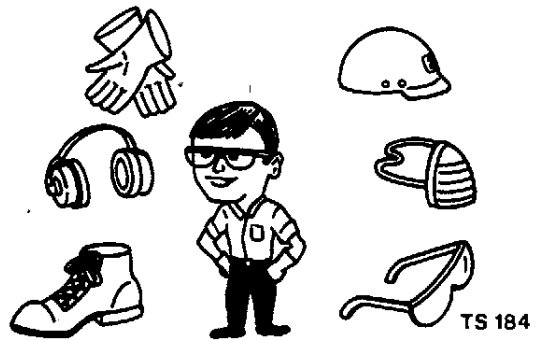

AB6-TS184 053-WEAR2 080785

STAY CLEAR OF PTO

Stop the engine and be sure the PTO drive line (A) has stopped before:

- Connecting or disconnecting implement drive line
- Making adjustments on the implement
- Cleaning out PTO driven equipment

PTO master shield (B) and drive lines should be in place at all times except for special applications as directed in the implement operator's manual.

Operate PTO at recommended speed.

Avoid loose-fitting or dangling clothing.

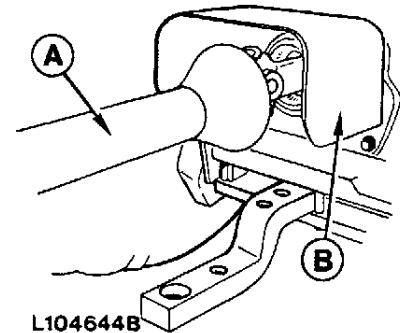

L104644B-2755ALE-011186



Suggest:

If the above button click is invalid.

Please download this document

first, and then click the above link

to download the complete manual.

Thank you so much for reading

SERVICE TRACTOR SAFELY

Do not service the tractor while it is in motion or while engine is running.

Disconnect battery ground cable before working on electrical system or working in any area where you might accidentally contact electrical components.

Reinstall all shields and guards removed for servicing and make sure they are in good condition.

Have adjustments carried out by trained personnel only.

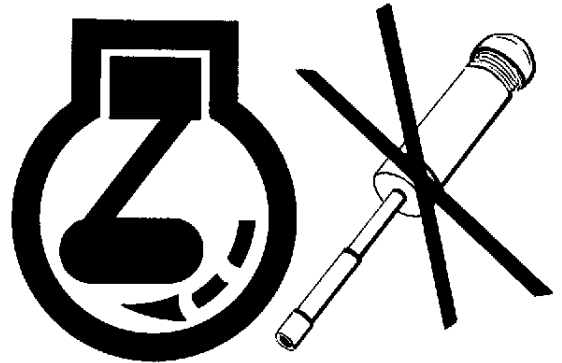

Z 20 919

Z20919-2950ALE-150585

TEST COOLANT HEATER IN LIQUID ONLY

Do not plug coolant heater into electrical power unless heating element is immersed in coolant. Sheath could burst and result in personal injury.

Use a heavy-duty grounded cord to connect coolant heater to electrical power.

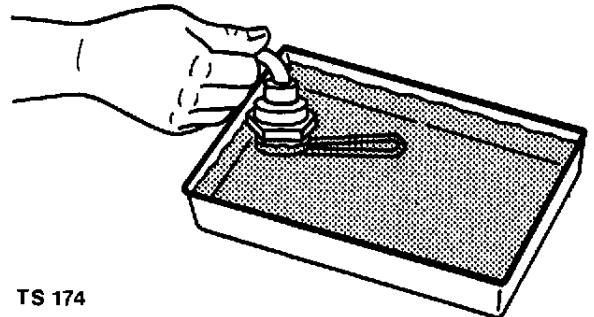

TS 174

AB6-TS174 053-HEAT 110584

<https://www.ebooklibonline.com>

Hello dear friend!

Thank you very much for reading.

Enter the link into your browser.

The full manual is available for immediate download.

<https://www.ebooklibonline.com>