

2048HV, 2254HV & 2554HV SABRE GARDEN TRACTORS

TECHNICAL MANUAL

**John Deere
Worldwide Commercial and
Consumer Equipment Division**

TM1741 (1Jul98)



Sabre 2048HV Garden Tractor



Sabre 2254HV Garden Tractor



Sabre 2554HV Garden Tractor

This technical manual is written for an experienced technician and contains sections that are specifically for this product. It is a part of a total product support program.

The manual is organized so that all the information on a particular system is kept together. The order of grouping is as follows:

- Table of Contents
- General Diagnostic Information
- Specifications
- Electrical Wiring Harness Legend
- Component Location
- System Schematic
- Wiring Harness
- Troubleshooting Chart
- Theory of Operation
- Diagnostics
- Tests & Adjustments
- Repair

Note: Depending on the particular section or system being covered, not all of the above groups may be used.

Each section will be identified with a symbol rather than a number. The groups and pages within a section will be consecutively numbered.

We appreciate your input on this manual. To help, there are postage paid post cards included at the back. If you find any errors or want to comment on the layout of the manual please fill out one of the cards and mail it back to us.

All information, illustrations and specifications in this manual are based on the latest information available at the time of publication. The right is reserved to make changes at any time without notice.

COPYRIGHT© 1998
Deere and Co.
John Deere Worldwide Commercial and
Consumer Equipment Division
Horicon, WI
All rights reserved

Safety 

Specifications and Information 

Engine (Briggs & Stratton) 

Engine (Kohler) 

Electrical 

Power Train (Hydrostatic) 

Steering 

Brakes 

Attachments 

Miscellaneous 

<https://www.ebooklibonline.com>

Hello dear friend!

Thank you very much for reading.

Enter the link into your browser.

The full manual is available for immediate download.

<https://www.ebooklibonline.com>



RECOGNIZE SAFETY INFORMATION



This is the safety-alert symbol. When you see this symbol on your machine or in this manual, be alert to the potential for personal injury.

Follow recommended precautions and safe servicing practices.

- **UNDERSTAND SIGNAL WORDS**

A signal word—DANGER, WARNING, or CAUTION—is used with the safety-alert symbol.

- **DANGER** identifies the most serious hazards. Danger or Warning safety signs are located near specific hazards.
- **CAUTION** safety signs are used where general precautions should be used. CAUTION also calls attention to safety messages in this manual.

REPLACE SAFETY SIGNS



Replace missing or damaged safety signs. See the machine operator's manual for correct safety sign placement.

HANDLE FLUIDS SAFELY-AVOID FIRES

- **BE PREPARED FOR EMERGENCIES**

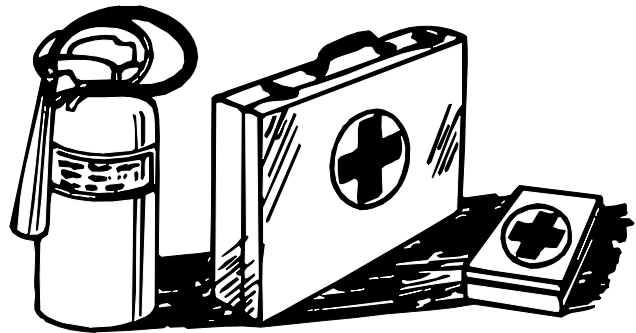

When you work around fuel, do not smoke or work near heaters or other fire hazards.

Store flammable fluids away from fire hazards. Do not incinerate or puncture pressurized containers.

Make sure machine is clean of trash, grease, and debris.

Do not store oily rags; they can ignite and burn spontaneously.

Be prepared if a fire starts.

Keep a first aid kit and fire extinguisher handy.

Keep emergency numbers for doctors, ambulance service, hospital, and fire department near your telephone.

USE CARE IN HANDLING AND SERVICING BATTERIES

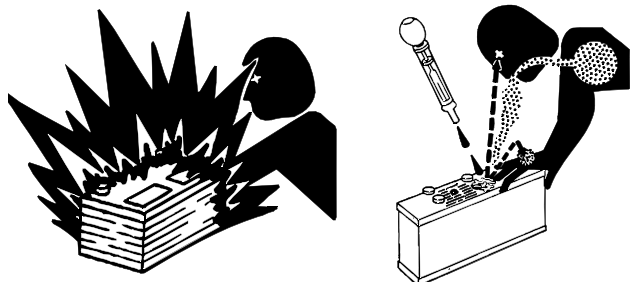

• PREVENT BATTERY EXPLOSIONS

- Keep sparks, lighted matches, and open flame away from the top of battery. Battery gas can explode.
- Never check battery charge by placing a metal object across the posts. Use a volt-meter or hydrometer.
- Do not charge a frozen battery; it may explode. Warm battery to 16°C (60°F).

• PREVENT ACID BURNS

- Sulfuric acid in battery electrolyte is poisonous. It is strong enough to burn skin, eat holes in clothing, and cause blindness if splashed into eyes.

• AVOID ACID BURNS BY:

1. Filling batteries in a well-ventilated area.
1. Wearing eye protection and rubber gloves.
1. Avoiding breathing fumes when electrolyte is added.
1. Avoiding spilling or dripping electrolyte.
1. Use proper jump start procedure.

• IF YOU SPILL ACID ON YOURSELF:

1. Flush your skin with water.
1. Apply baking soda or lime to help neutralize the acid.
1. Flush your eyes with water for 10_15 minutes.
1. Get medical attention immediately.

• IF ACID IS SWALLOWED:

1. Drink large amounts of water or milk.
1. Then drink milk of magnesia, beaten eggs, or vegetable oil.
1. Get medical attention immediately.

USE SAFE SERVICE PROCEDURES



• WEAR PROTECTIVE CLOTHING



Wear close fitting clothing and safety equipment appropriate to the job.

Prolonged exposure to loud noise can cause impairment or loss of hearing. Wear a suitable hearing protective device such as earmuffs or earplugs to protect against objectionable or uncomfortable loud noises.

Operating equipment safely requires the full attention of the operator. Do not wear radio or music headphones while operating machine.

• SERVICE MACHINES SAFELY

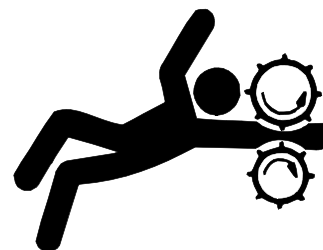

Tie long hair behind your head. Do not wear a necktie, scarf, loose clothing, or necklace when you work near machine tools or moving parts. If these items were to get caught, severe injury could result.

Remove rings and other jewelry to prevent electrical shorts and entanglement in moving parts.

• USE PROPER TOOLS

Use tools appropriate to the work. Makeshift tools and procedures can create safety hazards. Use power tools only to loosen threaded parts and fasteners. For loosening and tightening hardware, use the correct size tools. **DO NOT** use U.S. measurement tools on metric fasteners. Avoid bodily injury caused by slipping wrenches. Use only service parts meeting John Deere specifications.



• PARK MACHINE SAFELY

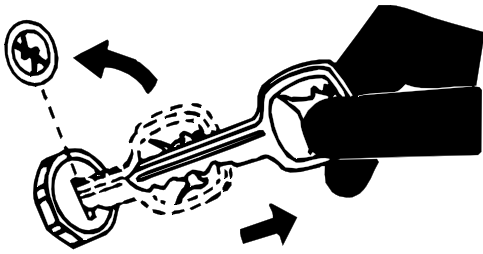

Before working on the machine:

1. Be sure all equipment is resting firmly on the ground.
2. Stop the engine.
3. Disconnect the spark plug.
4. Hang a "DO NOT OPERATE" tag in operator station.

• SUPPORT MACHINE PROPERLY AND USE PROPER LIFTING EQUIPMENT

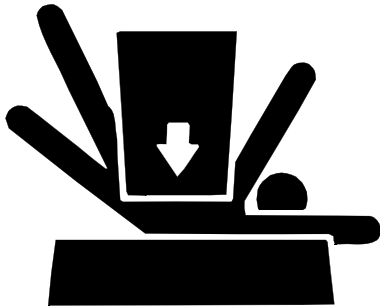

If you must work on a lifted machine or attachment, securely support the machine or attachment.

Do not support the machine on cinder blocks, hollow tiles, or props that may crumble under continuous load. Do not work under a machine that is supported solely by a jack. Follow recommended procedures in this manual.

Lifting heavy components incorrectly can cause severe injury or machine damage. Follow recommended procedure for removal and installation of components in the manual.

• WORK IN A CLEAN AREA

Before starting a job:

1. Clean work area and machine.
2. Make sure you have all necessary tools to do your job.
3. Have the right parts on hand.
4. Read all instructions thoroughly; do not attempt shortcuts.

• USING HIGH PRESSURE WASHERS

Directing pressurized water at electronic/electrical components or connectors, bearings, hydraulic seals, fuel injection pumps or other sensitive parts and components may cause product malfunctions. Reduce pressure and spray at a 45 to 90 degree angle.

• ILLUMINATE WORK AREA SAFELY

Illuminate your work area adequately but safely. Use a portable safety light for working inside or under the machine. Make sure the bulb is enclosed by a wire cage. The hot filament of an accidentally broken bulb can ignite spilled fuel or oil.

• WORK IN VENTILATED AREA

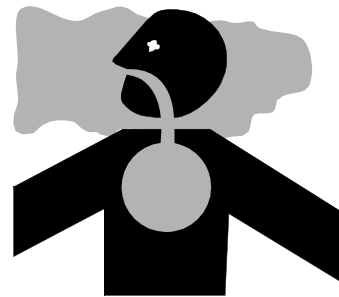

Engine exhaust fumes can cause sickness or death. If it is necessary to run an engine in an enclosed area, remove the exhaust fumes from the area with an exhaust pipe extension.

If you do not have an exhaust pipe extension, open the doors and get outside air into the area.

WARNING: California Proposition 65

Gasoline engine exhaust from this product contains chemicals known to the State of California to cause cancer, birth defects, or other reproductive harm.

• REMOVE PAINT BEFORE WELDING OR HEATING

Avoid potentially toxic fumes and dust. Hazardous fumes can be generated when paint is heated by welding, soldering, or using a torch. Do all work outside or in a well ventilated area. Dispose of paint and solvent properly. Remove paint before welding or heating: If you sand or grind paint, avoid breathing the dust. Wear an approved respirator. If you use solvent or paint stripper, remove stripper with soap and water before welding. Remove solvent or paint stripper containers and other flammable material from area. Allow fumes to disperse at least 15 minutes before welding or heating.

• AVOID HARMFUL ASBESTOS DUST

Avoid breathing dust that may be generated when handling components containing asbestos fibers. Inhaled asbestos fibers may cause lung cancer.

Components in products that may contain asbestos fibers are brake pads, brake band and lining assemblies, clutch plates, and some gaskets. The asbestos used in these components is usually found in a resin or sealed in some way. Normal handling is not hazardous as long as airborne dust containing asbestos is not generated.

Avoid creating dust. Never use compressed air for cleaning. Avoid brushing or grinding material containing asbestos. When servicing, wear an approved respirator. A special vacuum cleaner is recommended to clean asbestos. If not available, apply a mist of oil or water on the material containing asbestos. Keep bystanders away from the area.

SERVICE TIRES SAFELY



Explosive separation of a tire and rim parts can cause serious injury or death.

Do not attempt to mount a tire unless you have the proper equipment and experience to perform the job. Always maintain the correct tire pressure. Do not inflate the tires above the recommended pressure. Never weld or heat a wheel and tire assembly. The heat can cause an increase in air pressure resulting in a tire explosion. Welding can structurally weaken or deform the wheel.

When inflating tires, use a clip-on chuck and extension hose long enough to allow you to stand to one side and NOT in front of or over the tire assembly. Use a safety cage if available.

Check wheels for low pressure, cuts, bubbles, damaged rims or missing lug bolts and nuts.

AVOID INJURY FROM ROTATING BLADES, AUGERS AND PTO SHAFTS

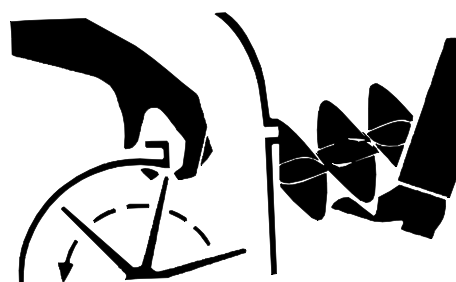
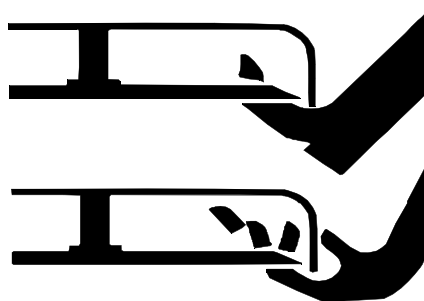

Keep hands and feet away while machine is running. Shut off engine before starting service. Do not defeat safety systems to allow machine to operate unattended.

HANDLE CHEMICAL PRODUCTS SAFELY

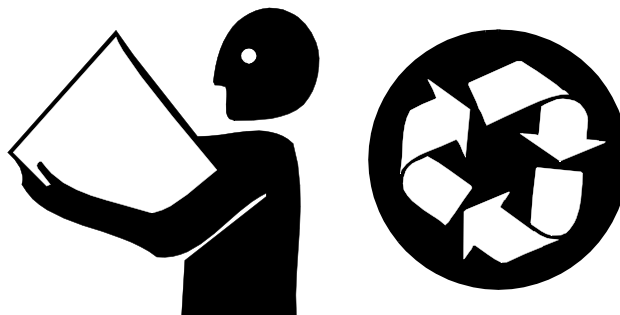

Direct exposure to hazardous chemicals can cause serious injury. Potentially hazardous chemicals used with John Deere equipment include such items as lubricants, coolants, paints, and adhesives.

A Material Safety Data Sheet (MSDS) provides specific details on chemical products: physical and health hazards, safety procedures, and emergency response techniques. Check the MSDS before you start any job using a hazardous chemical. That way you will know exactly what the risks are and how to do the job safely. Then follow procedures and recommended equipment.



Dispose of Waste Properly

Improperly disposing of waste can threaten the environment and ecology. Potentially harmful waste used with John Deere equipment include such items as oil, fuel, coolant, brake fluid, filters, and batteries. Use leakproof containers when draining fluids. Do not use food or beverage containers that may mislead someone into drinking from them. Do not pour waste onto the ground, down a drain, or into any water source. Inquire on the proper way to recycle or dispose of waste from your local environmental or recycling center, or from your John Deere dealer.

LIVE WITH SAFETY



Before returning machine to customer, make sure machine is functioning properly, especially the safety systems. Install all guards and shields.

CONTENTS

	Page
GENERAL VEHICLE SPECIFICATIONS	3
METRIC FASTENER TORQUE VALUES	6
INCH FASTENER TORQUE VALUES	7
GASOLINE— NORTH AMERICA	8
GASOLINE STORAGE— NORTH AMERICA	8
GASOLINE—EUROPE	9
GASOLINE STORAGE—EUROPE	9
ENGINE OIL—NORTH AMERICA	10
ENGINE OIL—EUROPE	10
ENGINE BREAK-IN OIL—NORTH AMERICA	11
ENGINE BREAK-IN OIL—EUROPE	12
ANTI-CORROSION GREASE	13
ALTERNATIVE LUBRICANTS	13
SYNTHETIC LUBRICANTS	13
LUBRICANT STORAGE	13
MIXING OF LUBRICANTS	13
CHASSIS GREASE—NORTH AMERICA	14
CHASSIS GREASE—EUROPE	14
HYDROSTATIC TRANSMISSION OIL —NORTH AMERICA	15
HYDROSTATIC TRANSMISSION OIL—EUROPE	15
PRODUCT IDENTIFICATION LOCATIONS	16
PRODUCT IDENTIFICATION NUMBER (PIN)	16
ENGINE IDENTIFICATION NUMBER—KOHLER	16
ENGINE IDENTIFICATION NUMBER—BRIGGS & STRATTON	16
HYDROSTATIC TRANSAXLE IDENTIFICATION NUMBER	16





GENERAL VEHICLE SPECIFICATIONS

ENGINE (2048HV)

Make Briggs & Stratton
 Model Name Vanguard V-Twin
 Model Number..... No. 351777
 Horsepower 14.9 kW (20 hp)
 Displacement 570 cm³ (34.7 cu in.)
 Oil Capacity
 w/o oil filter 1.42 L (1.5 qt)
 w/ oil filter 1.54 L (1.63 qt)
 Cylinders 2
 Stroke/Cycle 4
 Valves Overhead Valves
 Lubrication..... Fully Pressurized
 Oil Filter..... Single Element, Full Flow, Spin-On Filter
 Cooling System..... Air Cooled
 Air Cleaner Dual Stage (Paper Element w/Replaceable Outer Foam Pre-cleaner)
 Muffler..... Horizontal Discharge Below Frame

ENGINE (2254HV)

Make Briggs & Stratton
 Model Name Vanguard V-Twin
 Model Number..... No. 380777
 Horsepower 16.4 kW (22 hp)
 Displacement 627 cm³ (38.2 cu in.)
 Oil Capacity
 w/o oil filter 1.42 L (1.5 qt)
 w/ oil filter 1.54 L (1.63 qt)
 Cylinders 2
 Stroke/Cycle 4
 Valves Overhead Valves
 Lubrication..... Fully Pressurized
 Oil Filter..... Single Element, Full Flow, Spin-On Filter
 Cooling System..... Air Cooled
 Air Cleaner Dual Stage (Paper Element w/Replaceable Outer Foam Pre-cleaner)
 Muffler..... Horizontal Discharge Below Frame

ENGINE (2554HV)

Engine Kohler
 Model Number..... CV25-SPS69525
 Horsepower..... 18.6 kW (25 hp)
 Displacement 725 cm³ (44.0 cu in.)
 Oil Capacity
 w/o oil filter 1.42 L (1.5 qt)
 w/ oil filter 1.65 L (1.7 qt)
 Cylinders 2
 Stroke/Cycle 4
 Valves Overhead Valves
 Lubrication..... Fully Pressurized
 Oil Filter..... Single Element, Full Flow, Spin-On Filter
 Cooling System..... Air Cooled
 Air Cleaner Dual Stage
 Muffler..... Horizontal Discharge Below Frame





FUEL SYSTEM

Aspiration Natural
 Fuel Tank Location Rear
 Fuel Tank Capacity 11 L (3 U.S. gal)
 Fuel (minimum octane) Unleaded Gasoline, 87 Octane
 Fuel Delivery Float-Type Side Draft Carburetor
 Fuel Filter Replaceable In-Line

ELECTRICAL

Ignition Electronic Capacitor Discharge Ignition (CDI)
 Type of Starter Solenoid Shift
 Charging System Flywheel Alternator
 Battery Type BCI Group, U1
 Battery Voltage 12 V
 Battery Reserve Capacity at 25 Amp 38 minutes
 Battery Cold Cranking Amps at -18°C (0°F) 295 amps

TRANSAXLE (HYDROSTATIC)

Drive Train Belt Drive Transaxle with foot-controlled variable speed drive
 Transaxle Tuff-Torq Model K-65
 Travel Speed-Forward 0-8.8 km/h (0-5.5 mph)
 Travel Speed-Reverse 0-3.5 km/h (0-2.5 mph)

PTO DRIVE

Type V-Belt
 Clutch Type Engine-Mounted, Electric
 Control Switch on dash

STEERING

Type Sector and Pinion

IMPLEMENT LIFT

Lift System Manual with Lift-Assist Spring
 Lift Lever Location Left-hand side of hood

DIMENSIONS-MODEL NUMBER 2048HV

Overall Height 114.0 cm (44.9 in.)
 Overall Length 182.9 cm (72 in.)
 Vehicle Weight 259 kg (570 lb)

DIMENSIONS-MODEL NUMBER 2254HV

Overall Height 115.7 cm (45.6 in.)
 Overall Length 183.6 cm (72.3 in.)
 Vehicle Weight 275 kg (606 lb)

DIMENSIONS-MODEL NUMBER 2554HV

Overall Height 115.7 cm (45.6 in.)
 Overall Length 183.6 cm (72.3 in.)
 Vehicle Weight 275 kg (606 lb)

TIRES

Size-Front-Model Number 2048HV	16 X 6.5
Size-Front-Model Number 2254HV	16 X 7.5
Size-Front-Model Number 2554HV	16 X 7.5
Size-Rear-Model Number 2048HV	23 X 10.5
Size-Rear-Model Number 2254HV	24 X 12
Size-Rear-Model Number 2554HV	24 X 12



MOWER DECK (48-INCH)

Blades	3
Cutting Height-Approx.	25–102 mm (1–4 in.)
Blade Length	42.3 cm (16.6 in.)
Cutting Width	121.9 cm (48 in.)
Overall Width	153.4 cm (60.375 in.)
Overall Width with Deflector Up	131.1 cm (51.625 in.)

MOWER DECK (54-INCH)

Blades	3
Cutting Height-Approx.	25–102 mm (1–4 in.)
Blade Length	47.4 cm (18.7 in.)
Cutting Width	137.2 cm (54 in.)
Overall Width	168.6 cm (66.375 in.)
Overall Width with Deflector Up	146.3 cm (57.625 in.)

METRIC FASTENER TORQUE VALUES

Property Class and Head Markings	4.8		8.8		9.8		10.9		12.9	
Property Class and Nut Markings	5		10		10		10		12	

TS1163

SIZE	Class 4.8				Class 8.8 or 9.8				Class 10.9				Class 12.9			
	Lubricated ^a		Dry ^a		Lubricated ^a		Dry ^a		Lubricated ^a		Dry ^a		Lubricated ^a		Dry ^a	
	N•m	lb-ft	N•m	lb-ft	N•m	lb-ft	N•m	lb-ft	N•m	lb-ft	N•m	lb-ft	N•m	lb-ft	N•m	lb-ft
M6	4.8	3.5	6	4.5	9	6.5	11	8.5	13	9.5	17	12	15	11.5	19	14.5
M8	12	8.5	15	11	22	16	28	20	32	24	40	30	37	28	47	35
M10	23	17	29	21	43	32	55	40	63	47	80	60	75	55	95	70
M12	40	29	50	37	75	55	95	70	110	80	140	105	130	95	165	120
M14	63	47	80	60	120	88	150	110	175	130	225	165	205	150	260	109
M16	100	73	125	92	190	140	240	175	275	200	350	225	320	240	400	300
M18	135	100	175	125	260	195	330	250	375	275	475	350	440	325	560	410
M20	190	140	240	180	375	275	475	350	530	400	675	500	625	460	800	580
M22	260	190	330	250	510	375	650	475	725	540	925	675	850	625	1075	800
M24	330	250	425	310	650	475	825	600	925	675	1150	850	1075	800	1350	1000
M27	490	360	625	450	950	700	1200	875	1350	1000	1700	1250	1600	1150	2000	1500
M30	675	490	850	625	1300	950	1650	1200	1850	1350	2300	1700	2150	1600	2700	2000
M33	900	675	1150	850	1750	1300	2200	1650	2500	1850	3150	2350	2900	2150	3700	2750
M36	1150	850	1450	1075	2250	1650	2850	2100	3200	2350	4050	3000	3750	2750	4750	3500

DO NOT use these hand torque values if a different torque value or tightening procedure is given for a specific application. Torque values listed are for general use only and include a ±10% variance factor. Check tightness of fasteners periodically. DO NOT use air powered wrenches.

Shear bolts are designed to fail under predetermined loads. Always replace shear bolts with identical grade.

Fasteners should be replaced with the same class. Make sure fastener threads are clean and that you properly start thread engagement. This will prevent them from failing when tightening.











When bolt and nut combination fasteners are used, torque values should be applied to the **NUT** instead of the bolt head.

Tighten toothed or serrated-type lock nuts to the full torque value.

^a "Lubricated" means coated with a lubricant such as engine oil, or fasteners with phosphate and oil coatings. "Dry" means plain or zinc plated (yellow dichromate - Specification JDS117) without any lubrication.

Reference: JDS—G200.

INCH FASTENER TORQUE VALUES

SAE Grade and Head Markings	1 or 2 ^b No Marks 	5  5.1  5.2 	8  8.2 
	2 No Marks 	5  	8  

TS1162



SIZE	Grade 1		Grade 2 ^b				Grade 5, 5.1 or 5.2				Grade 8 or 8.2					
	Lubricated ^a		Dry ^a		Lubricated ^a		Dry ^a		Lubricated ^a		Dry ^a		Lubricated ^a		Dry ^a	
	N•m	lb-ft	N•m	lb-ft	N•m	lb-ft	N•m	lb-ft	N•m	lb-ft	N•m	lb-ft	N•m	lb-ft	N•m	lb-ft
1/4	3.7	2.8	4.7	3.5	6	4.5	7.5	5.5	9.5	7	12	9	13.5	10	17	12.5
5/16	7.7	5.5	10	7	12	9	15	11	20	15	25	18	28	21	35	26
3/8	14	10	17	13	22	16	27	20	35	26	44	33	50	36	63	46
7/16	22	16	28	20	35	26	44	32	55	41	70	52	80	58	100	75
1/2	33	25	42	31	53	39	67	50	85	63	110	80	120	90	150	115
9/16	48	36	60	45	75	56	95	70	125	90	155	115	175	130	225	160
5/8	67	50	85	62	105	78	135	100	170	125	215	160	215	160	300	225
3/4	120	87	150	110	190	140	240	175	300	225	375	280	425	310	550	400
7/8	190	140	240	175	190	140	240	175	490	360	625	450	700	500	875	650
1	290	210	360	270	290	210	360	270	725	540	925	675	1050	750	1300	975
1-1/8	470	300	510	375	470	300	510	375	900	675	1150	850	1450	1075	1850	1350
1-1/4	570	425	725	530	570	425	725	530	1300	950	1650	1200	2050	1500	2600	1950
1-3/8	750	550	950	700	750	550	950	700	1700	1250	2150	1550	2700	2000	3400	2550
1-1/2	1000	725	1250	925	990	725	1250	930	2250	1650	2850	2100	3600	2650	4550	3350

DO NOT use these hand torque values if a different torque value or tightening procedure is given for a specific application. Torque values listed are for general use only and include a ±10% variance factor. Check tightness of fasteners periodically. DO NOT use air powered wrenches.

Shear bolts are designed to fail under predetermined loads. Always replace shear bolts with identical grade.

Fasteners should be replaced with the same grade. Make sure fastener threads are clean and that you properly start thread engagement. This will prevent them from failing when tightening.

When bolt and nut combination fasteners are used, torque values should be applied to the **NUT** instead of the bolt head.

Tighten toothed or serrated-type lock nuts to the full torque value.

^a "Lubricated" means coated with a lubricant such as engine oil, or fasteners with phosphate and oil coatings. "Dry" means plain or zinc plated (yellow dichromate - Specification JDS117) without any lubrication.

^b "Grade 2" applies for hex cap screws (not hex bolts) up to 152 mm (6-in.) long. "Grade 1" applies for hex cap screws over 152 mm (6-in.) long, and for all other types of bolts and screws of any length.

Reference: JDS—G200.

GASOLINE— NORTH AMERICA



Gasoline is **HIGHLY FLAMMABLE**, handle it with care.

DO NOT refuel machine while:

- indoors, always fill gas tank outdoors;
- machine is near an open flame or sparks;
- engine is running, **STOP** engine;
- engine is hot, allow it to cool sufficiently first;
- smoking.

Help prevent fires:

- fill gas tank to bottom of filler neck only;
- be sure fill cap is tight after fueling;
- clean up any gas spills **IMMEDIATELY**;
- keep machine clean and in good repair—free of excess grease, oil, debris, and faulty or damaged parts;
- any storage of machines with gas left in tank should be in an area that is well ventilated to prevent possible igniting of fumes by an open flame or spark, this includes any appliance with a pilot light.

To prevent fire or explosion caused by STATIC ELECTRIC DISCHARGE during fueling:

- **ONLY** use a clean, approved **POLYETHYLENE PLASTIC** fuel container and funnel **WITHOUT** any metal screen or filter.



CAUTION



STOP ENGINE

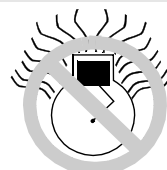

NO HOT ENGINE



NO SMOKING

NO OPEN FLAME
OR SPARKNO STATIC ELECTRIC
DISCHARGE

To avoid engine damage:

- DO NOT mix oil with gasoline;
- **ONLY** use clean, fresh unleaded gasoline with an octane rating (anti-knock index) of 87 or higher;
- fill gas tank at the end of each day's operation to help prevent condensation from forming inside a partially filled tank;
- keep up with specified service intervals.

Use of alternative oxygenated, gasohol blended, unleaded gasoline is acceptable as long as:

- the ethyl or grain alcohol blends DO NOT exceed 10% by volume or
- methyl tertiary butyl ether (MTBE) blends DO NOT exceed 15% by volume.



IMPORTANT: DO NOT use **METHANOL** gasoline because **METHANOL** is harmful to the environment and to your health.



WARNING

California Proposition 65 Warning: Gasoline engine exhaust from this product contains chemicals known to the State of California to cause cancer, birth defects, or other reproductive harm.

GASOLINE STORAGE— NORTH AMERICA

IMPORTANT: Keep all dirt, scale, water or other foreign material out of gasoline.

Keep gasoline stored in a safe, protected area. Storage of gasoline in a clean, properly marked ("**UNLEADED GASOLINE**") **POLYETHYLENE PLASTIC** container **WITHOUT** any metal screen or filter is recommended. **DO NOT** use de-icers to attempt to remove water from gasoline or depend on fuel filters to remove water from gasoline. Use a water separator installed in the storage tank outlet. **BE SURE** to properly discard unstable or contaminated gasoline. When storing unit or gasoline, it is recommended that you add **John Deere Gasoline Conditioner and Stabilizer (TY15977)** or an equivalent to the gasoline. **BE SURE** to follow directions on container and to properly discard empty container.

GASOLINE—EUROPE

 **CAUTION**

Gasoline is **HIGHLY FLAMMABLE**, handle it with care.

DO NOT refuel machine while:

- indoors, always fill gas tank outdoors;
- machine is near an open flame or sparks;
- engine is running, **STOP** engine;
- engine is hot, allow it to cool sufficiently first;
- smoking.

Help prevent fires:

- fill gas tank to bottom of filler neck only;
- be sure fill cap is tight after fueling;
- clean up any gas spills **IMMEDIATELY**;
- keep machine clean and in good repair—free of excess grease, oil, debris, and faulty or damaged parts;
- any storage of machines with gas left in tank should be in an area that is well ventilated to prevent possible igniting of fumes by an open flame or spark, this includes any appliance with a pilot light.

To prevent fire or explosion caused by STATIC ELECTRIC DISCHARGE during fueling:

- **ONLY** use a clean, approved **POLYETHYLENE PLASTIC** fuel container and funnel **WITHOUT** any metal screen or filter.

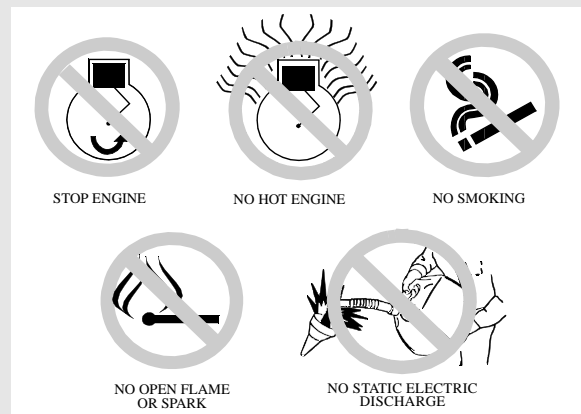

To avoid engine damage:

- DO NOT mix oil with gasoline;
- **ONLY** use clean, fresh unleaded gasoline with an octane rating (anti-knock index) of 87 or higher;
- fill gas tank at the end of each day's operation to help prevent condensation from forming inside a partially filled tank;
- keep up with specified service intervals.

Use of alternative oxygenated, gasohol blended, unleaded gasoline is acceptable as long as:

- the ethyl or grain alcohol blends DO NOT exceed 10% by volume or
- methyl tertiary butyl ether (MTBE) blends DO NOT exceed 15% by volume.



IMPORTANT: DO NOT use **METHANOL** gasoline because **METHANOL** is harmful to the environment and to your health.

GASOLINE STORAGE—EUROPE

IMPORTANT: Keep all dirt, scale, water or other foreign material out of gasoline.

Keep gasoline stored in a safe, protected area. Storage of gasoline in a clean, properly marked (“**UNLEADED GASOLINE**”) **POLYETHYLENE PLASTIC** container **WITHOUT** any metal screen or filter is recommended. **DO NOT** use de-icers to attempt to remove water from gasoline or depend on fuel filters to remove water from gasoline. Use a water separator installed in the storage tank outlet. **BE SURE** to properly discard unstable or contaminated gasoline. When storing unit or gasoline, it is recommended that you add **John Deere Gasoline Conditioner and Stabilizer (TY15977)** or an equivalent to the gasoline. **BE SURE** to follow directions on container and to properly discard empty container.

ENGINE OIL—NORTH AMERICA

Use the appropriate oil viscosity based on the expected air temperature range during the period between recommended oil changes. Operating outside of these recommended oil air temperature ranges may cause premature engine failure.

The following John Deere oil is **PREFERRED**:

- **TORQ-GARD SUPREME®—SAE 5W-30.**

The following John Deere oils are **also recommended**, based on their specified temperature range:

- **TURF-GARD®—SAE 10W-30;**
- **PLUS-4®—SAE 10W-30;**
- **TORQ-GARD SUPREME®—SAE 30.**

Other oils may be used if above John Deere oils are not available, provided they meet one of the following specifications:

- SAE 5W-30—API Service Classification SG or higher;
- SAE 10W-30—API Service Classification SG or higher;
- SAE 30—API Service Classification SC or higher.

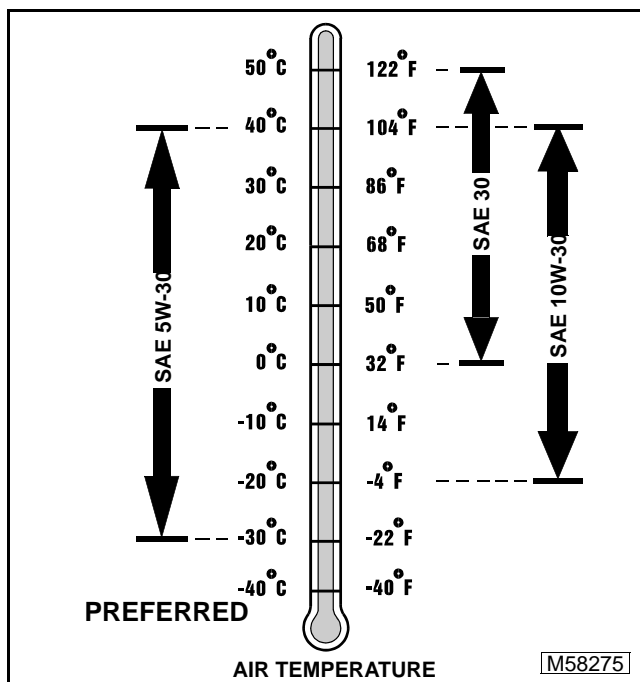

John Deere Dealers: You may want to cross-reference the following publications to recommend the proper oil for your customers:

- Module DX, ENOIL2 in JDS-G135;
- Section 530, Lubricants & Hydraulics, of the John Deere Merchandise Sales Guide;
- Lubrication Sales Manual PI7032.

ENGINE OIL—EUROPE

Use the appropriate oil viscosity based on their expected air temperature range during the period between recommended oil changes. Operating outside of these recommended oil air temperature ranges may cause premature engine failure.

The following John Deere oils are **PREFERRED**:

- **TORQ-GARD SUPREME®—SAE 5W-30;**
- **UNI-GARD™—SAE 5W-30.**

The following John Deere oils are **also recommended**, based on their specified temperature range:

- **TORQ-GARD SUPREME®—SAE 10W-30;**
- **UNI-GARD™—SAE 10W-30;**
- **TORQ-GARD SUPREME®—SAE 30**
- **UNI-GARD™—SAE 30.**

Other oils may be used if above John Deere oils are not available, provided they meet one of the following specifications:

- CCMC Specification G4 or higher.

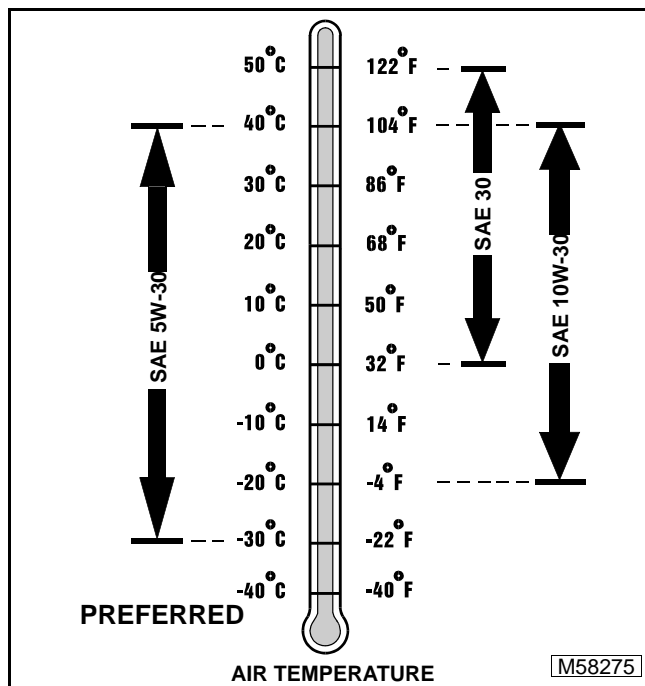

John Deere Dealers: You may want to cross-reference the following publications to recommend the proper oil for your customers:

- Module DX, ENOIL2 in JDS-G135;
- Section 530, Lubricants & Hydraulics, of the John Deere Merchandise Sales Guide.

ENGINE BREAK-IN OIL—NORTH AMERICA

IMPORTANT: ONLY use a quality break-in oil in rebuilt or remanufactured engines for the first 5 hours (maximum) of operation. DO NOT use oils with heavier viscosity weights than SAE 5W-30 or oils meeting specifications API SG or SH, these oils will not allow rebuilt or remanufactured engines to break-in properly.

The following John Deere oil is **PREFERRED**:

- **BREAK-IN ENGINE OIL.**

John Deere BREAK-IN ENGINE OIL is formulated with special additives for aluminum and cast iron type engines to allow the power cylinder components (pistons, rings, and liners as well) to “wear-in” while protecting other engine components, valve train and gears, from abnormal wear. Engine rebuild instructions should be followed closely to determine if special requirements are necessary.

John Deere BREAK-IN ENGINE OIL is also recommended for non-John Deere engines, both aluminum and cast iron types.

The following John Deere oil is **also recommended** as a break-in engine oil:

- **TORQ-GARD SUPREME®—SAE 5W-30.**

If the above recommended John Deere oils are not available, use a break-in engine oil meeting the following specification during the first 5 hours (maximum) of operation:

- SAE 5W-30—API Service Classification SE or higher.

IMPORTANT: After the break-in period, use the John Deere oil that is recommended for this engine.

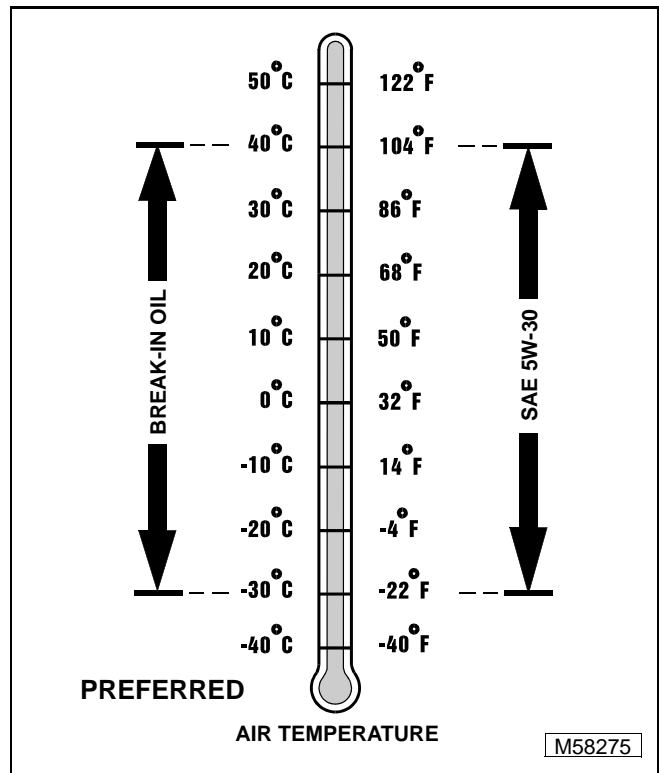

John Deere Dealers: You may want to cross-reference the following publications to recommend the proper oil for your customers:

- Module DX, ENOIL4 in JDS-G135;
- Section 530, Lubricants & Hydraulics, of the John Deere Merchandise Sales Guide;
- Lubrication Sales Manual PI7032.

ENGINE BREAK-IN OIL—EUROPE

IMPORTANT: ONLY use a quality break-in oil in rebuilt or remanufactured engines for the first 5 hours (maximum) of operation. DO NOT use oils with heavier viscosity weights than SAE 5W-30 or oils meeting CCMC Specification G5—these oils will not allow rebuilt or remanufactured engines to break-in properly.

The following John Deere oil is **PREFERRED**:

- **BREAK-IN ENGINE OIL.**

John Deere **BREAK-IN ENGINE OIL** is formulated with special additives for aluminum and cast iron type engines to allow the power cylinder components (pistons, rings, and liners as well) to “wear-in” while protecting other engine components, valve train and gears, from abnormal wear. Engine rebuild instructions should be followed closely to determine if special requirements are necessary.

John Deere **BREAK-IN ENGINE OIL** is also recommended for non-John Deere engines, both aluminum and cast iron types.

The following John Deere oil is **also recommended** as a break-in engine oil:

- **TORQ-GARD SUPREME®—SAE 5W-30.**

If the above recommended John Deere oils are not available, use a break-in engine oil meeting the following specification during the first 5 hours (maximum) of operation:

- SAE 5W-30—CCMC Specification G4 or higher.

IMPORTANT: After the break-in period, use the John Deere oil that is specified for this engine.

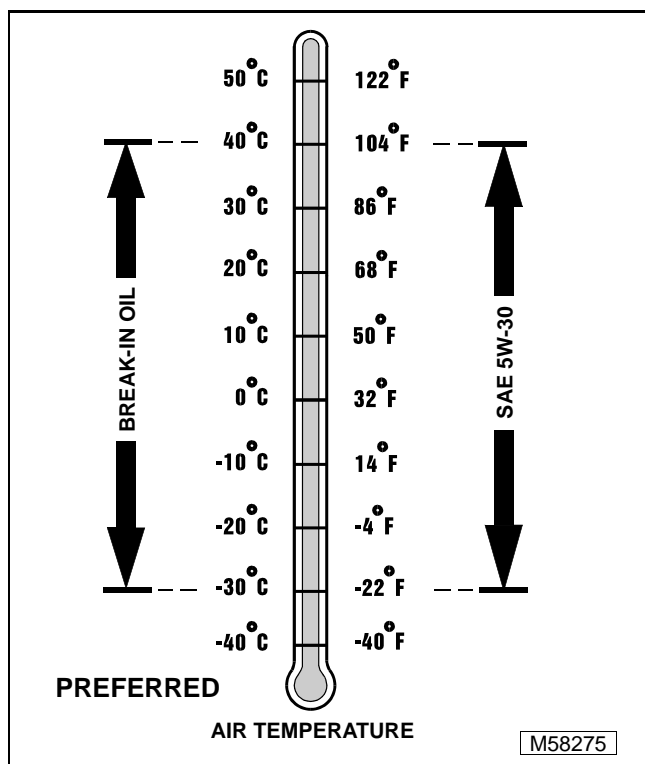

John Deere Dealers: You may want to cross-reference the following publications to recommend the proper oil for your customers:

- Module DX, ENOIL4 in JDS-G135;
- Section 530, Lubricants & Hydraulics, of the John Deere Merchandise Sales Guide.

ANTI-CORROSION GREASE

This anti-corrosion grease is formulated to provide the best protection against absorbing moisture, which is one of the major causes of corrosion. This grease is also superior in its resistance to separation and migration.

The following anti-corrosion grease is **PREFERRED**:

- DuBois MPG-2® Multi-Purpose Polymer Grease—M79292.

Other greases may be used if they meet or exceed the following specifications:

- John Deere Standard JDM J13A2, NLGI Grade 1.

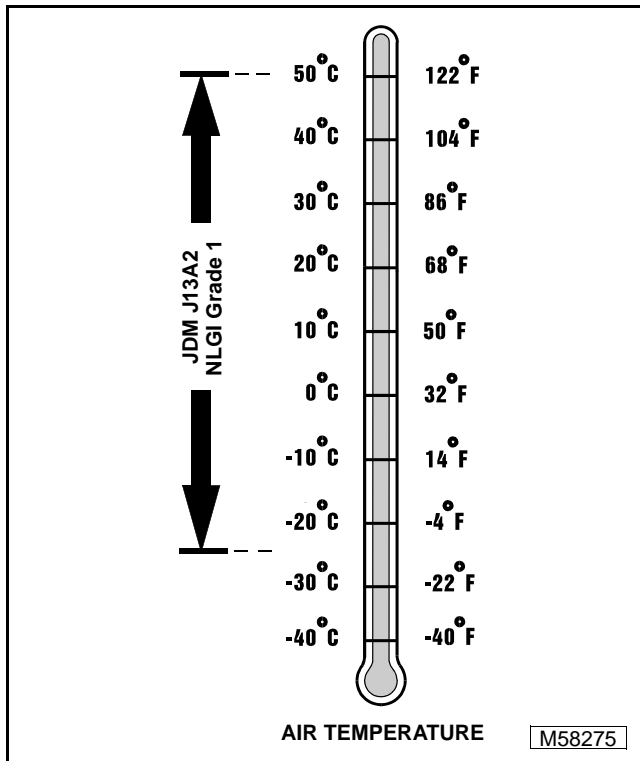

John Deere Dealers: You may want to cross-reference the following publications to recommend the proper grease for your customers:

- Module DX,GREA1 in JDS–G135;
- Section 530, Lubricants & Hydraulics, of the John Deere Merchandise Sales Guide;
- Lubrication Sales Manual PI7032.

ALTERNATIVE LUBRICANTS

Conditions in certain geographical areas outside the United States and Canada may require different lubricant recommendations than the ones printed in this technical manual or the operator's manual. Consult with your John Deere Dealer, or Sales Branch, to obtain the alternative lubricant recommendations.



IMPORTANT: Use of alternative lubricants could cause reduced life of the component.

If alternative lubricants are to be used, it is recommended that the factory fill be thoroughly removed before switching to any alternative lubricant.

SYNTHETIC LUBRICANTS

Synthetic lubricants may be used in John Deere equipment if they meet the applicable performance requirements (industry classification and/or military specification) as shown in this manual.

The recommended air temperature limits and service or lubricant change intervals should be maintained as shown in the operator's manual.

Avoid mixing different brands, grades, or types of oil. Oil manufacturers blend additives in their oils to meet certain specifications and performance requirements. Mixing different oils can interfere with the proper functioning of these additives and degrade lubricant performance.

LUBRICANT STORAGE

All machines operate at top efficiency only when clean lubricants are used. Use clean storage containers to handle all lubricants. Store them in an area protected from dust, moisture, and other contamination. Store drums on their sides. Make sure all containers are properly marked as to their contents. Dispose of all old, used containers and their contents properly.

MIXING OF LUBRICANTS

In general, avoid mixing different brands or types of lubricants. Manufacturers blend additives in their lubricants to meet certain specifications and performance requirements. Mixing different lubricants can interfere with the proper functioning of these additives and lubricant properties which will downgrade their intended specified performance.

CHASSIS GREASE—NORTH AMERICA

Use the following grease based on the air temperature range. Operating outside of the recommended grease air temperature range may cause premature failures.

IMPORTANT: ONLY use a quality grease in this application. DO NOT mix any other greases in this application. DO NOT use any BIO-GREASE in this application.

The following John Deere grease is **PREFERRED**:

- **NON-CLAY HIGH-TEMPERATURE EP GREASE®—JDM J13E4, NLGI Grade 2.**

Other greases may be used if above preferred John Deere grease is not available, provided they meet the following specification:

- John Deere Standard JDM J13E4, NLGI Grade 2.

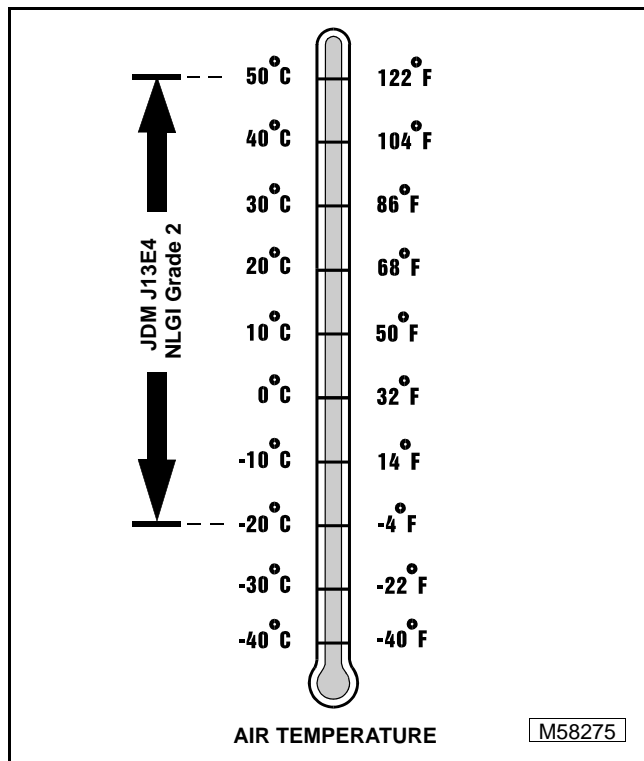

John Deere Dealers: You may want to cross-reference the following publications to recommend the proper grease for your customers:

- Module DX,GREA1 in JDS-G135;
- Section 530, Lubricants & Hydraulics, of the John Deere Merchandise Sales Guide;
- Lubrication Sales Manual P17032.

CHASSIS GREASE—EUROPE

Use the following grease based on the air temperature range. Operating outside of the recommended grease air temperature range may cause premature failures.

IMPORTANT: ONLY use a quality grease in this application. DO NOT mix any other greases in this application. DO NOT use any BIO-GREASE in this application.

The following John Deere grease is **PREFERRED**:

- **GREASE-GARD™—JDM J13E4, NLGI Grade 2.**

Other greases may be used if above preferred John Deere grease is not available, provided they meet the following specification:

- John Deere Standard JDM J13E4, NLGI Grade 2.

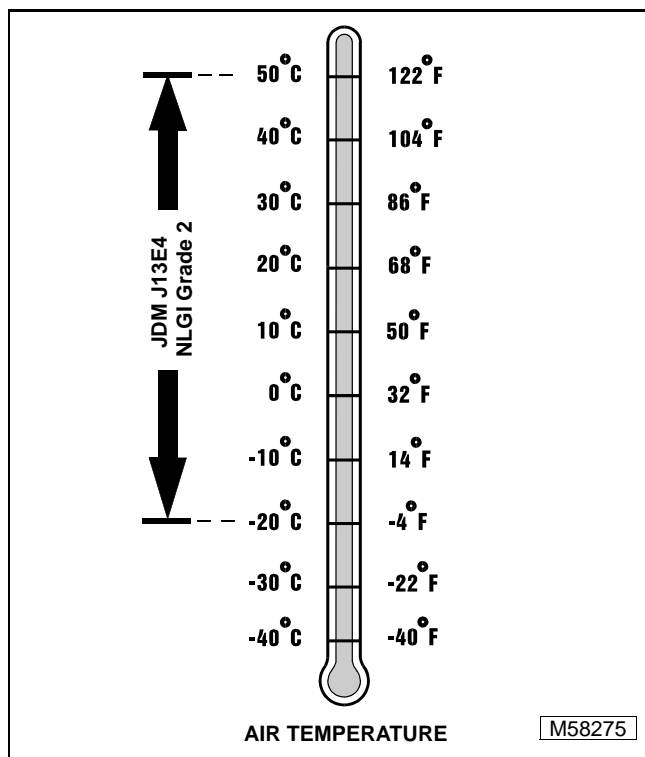

John Deere Dealers: You may want to cross-reference the following publications to recommend the proper grease for your customers:

- Module DX,GREA1 in JDS-G135;
- Section 530, Lubricants & Hydraulics, of the John Deere Merchandise Sales Guide.

HYDROSTATIC TRANSMISSION OIL —NORTH AMERICA

Use the appropriate oil viscosity based on these air temperature ranges. Operating outside of these recommended oil air temperature ranges may cause premature hydrostatic transmission failure.

IMPORTANT: ONLY use a quality SAE 5W-30 SYNTHETIC engine oil in this transmission. Mixing of two viscosity grade oils is NOT RECOMMENDED. DO NOT use BIO-HY-GARD® in this transmission.

The following oil is **RECOMMENDED**:

- 5W-50 SYNTHETIC OIL

Use only oils that meet the following specifications:

- API Service Classifications SG or higher.

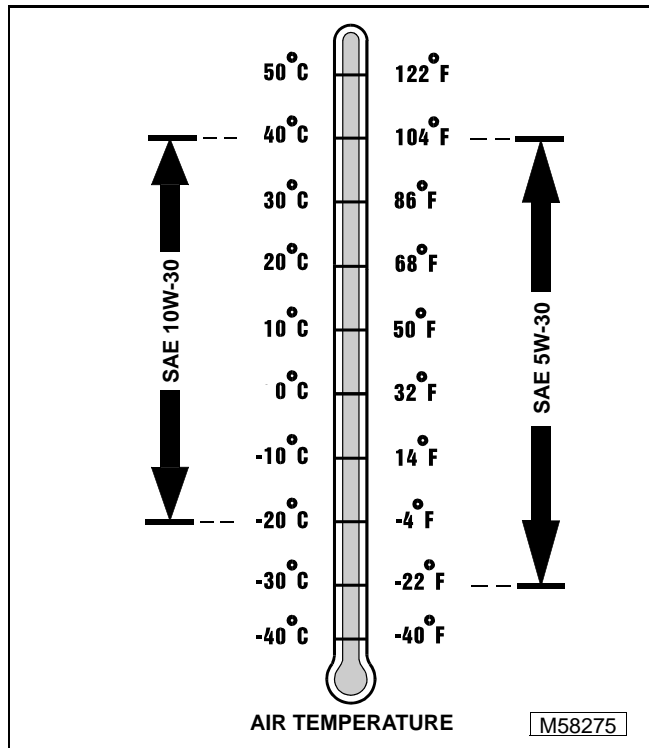

John Deere Dealers: You may want to cross-reference the following publications to recommend the proper oil for your customers:

- Module DX, ENOIL2 in JDS-G135;
- Section 530, Lubricants & Hydraulics, of the John Deere Merchandise Sales Guide;
- Lubrication Sales Manual PI7032.

HYDROSTATIC TRANSMISSION OIL—EUROPE

Use the appropriate oil viscosity based on these air temperature ranges. Operating outside of these recommended oil air temperature ranges may cause premature hydrostatic transmission failure.

IMPORTANT: ONLY use a quality SAE 5W-30 SYNTHETIC engine oil in this transmission. Mixing of two viscosity grade oils is NOT RECOMMENDED. DO NOT use BIO-HY-GARD® in this transmission.

The following oil is **RECOMMENDED**:

- 5W-50 SYNTHETIC OIL

Use only oils that meet the following specifications:

- CCMC Specifications G4 or higher.

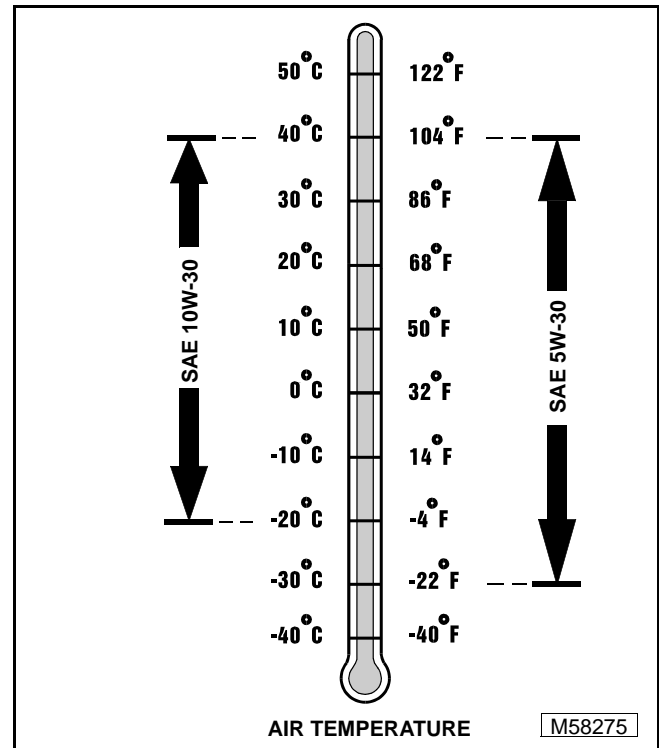

John Deere Dealers: You may want to cross-reference the following publications to recommend the proper oil for your customers:

- Module DX, ENOIL2 in JDS-G135;
- Section 530, Lubricants & Hydraulics, of the John Deere Merchandise Sales Guide.

PRODUCT IDENTIFICATION LOCATIONS

When ordering parts or submitting a warranty claim, it is **IMPORTANT** that you include the product identification number and the component product identification numbers.

The location of identification numbers and component product identification numbers are shown.

PRODUCT IDENTIFICATION NUMBER (PIN)



ENGINE IDENTIFICATION NUMBER—BRIGGS & STRATTON



HYDROSTATIC TRANSAXLE IDENTIFICATION NUMBER

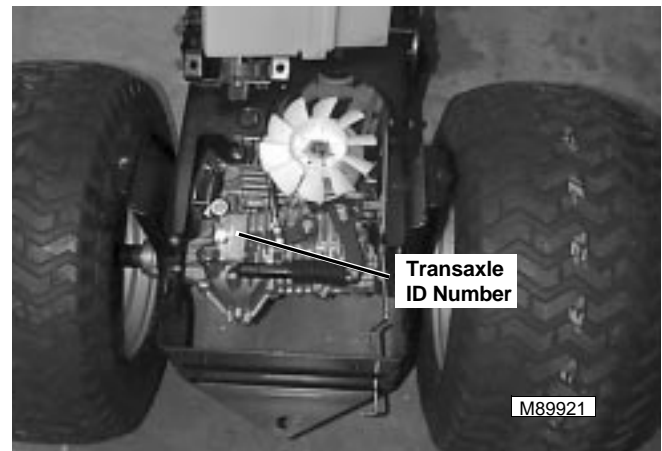

ENGINE IDENTIFICATION NUMBER—KOHLER

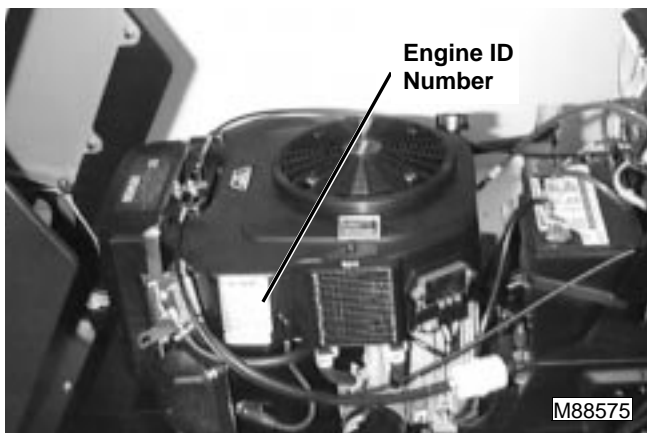

CONTENTS

	Page
SPECIFICATIONS—BRIGGS & STRATTON 14.91 kW (20.0 hp)	3
GENERAL SPECIFICATIONS	3
REPAIR SPECIFICATIONS	3
TORQUE SPECIFICATIONS	4
TESTS & ADJUSTMENTS SPECIFICATIONS	4
SPECIFICATIONS—BRIGGS & STRATTON 16.40 kW (22.0 hp)	5
GENERAL SPECIFICATIONS	5
REPAIR SPECIFICATIONS	5
TORQUE SPECIFICATIONS	6
TESTS & ADJUSTMENTS SPECIFICATIONS	6
TROUBLESHOOTING	7
ENGINE TROUBLESHOOTING GUIDE	9
ENGINE CRANKS BUT WILL NOT START	10
ENGINE RUNS ERRATICALLY/LOSS OF POWER	11
TESTS & ADJUSTMENTS	12
THROTTLE CABLE ADJUSTMENT	12
CHOKE CABLE ADJUSTMENT	12
FUEL SHUTOFF SOLENOID TEST	12
COMPRESSION TEST	13
CARBURETOR ADJUSTMENT	15
GOVERNOR ADJUSTMENT	16
VALVE CLEARANCE ADJUSTMENT	17
CYLINDER BALANCE TEST	17
REPAIR	18
UPPER BLOWER HOUSING REMOVAL/INSTALLATION	18
AIR CLEANER REMOVAL AND INSTALLATION	19
CARBURETOR REMOVAL/INSTALLATION	19
CARBURETOR DISASSEMBLY AND ASSEMBLY	21
ENGINE REMOVAL AND INSTALLATION	26
CYLINDER AIR GUIDES REMOVAL/INSTALLATION	27
INTAKE MANIFOLD REMOVAL/INSTALLATION	28
CYLINDER HEAD REMOVAL/INSTALLATION	28
CYLINDER HEAD INSPECTION & REPAIR	30
VALVE REMOVAL	31
VALVE INSPECTION & REPAIR	31
VALVE GUIDES REAM	32
VALVE INSTALLATION	33
PISTON, RINGS & ROD REMOVAL/INSTALLATION	33
CONNECTING ROD INSPECTION	35
CYLINDER BORE INSPECTION	37
CYLINDER BORE HONING	37
CYLINDER BORE CLEANING	37
RESIZING CYLINDER BORE	38
FLYWHEEL REMOVAL/INSTALLATION	38





	Page
CRANKSHAFT & CAM GEAR REMOVAL/INSTALLATION	39
MAGNETO BEARING INSPECTION	42
PTO AND CAM BEARING INSPECTION.....	43
LUBRICATION	43
BREATHER VALVE SERVICE	43
STARTER REMOVAL /INSTALLATION.....	45
STARTER DISASSEMBLY	46
STARTER ASSEMBLY	48
STARTER PINION GEAR REPLACEMENT.....	49

SPECIFICATIONS—BRIGGS & STRATTON 14.91 kW (20.0 hp)

GENERAL SPECIFICATIONS

Make	Briggs & Stratton
Series	Vanguard V-Twin
Type	1130-A1 Gasoline
Model	351777
Horsepower	14.91 kW (20.0 hp)
Cylinders	2
Displacement	570 cc (34.7 cu. in.)
Stroke/Cycle	4
Bore	72 mm (2.83 in.)
Stroke	70 mm (2.76 in.)
Valving	Overhead Valves
Lubrication	Pressurized
Oil Filter	Full Flow Filter (w/o By-Pass Valve)
Oil Capacity	
w/o oil filter	1.42 L (1.5 qt)
w/ oil filter	1.65 L (1.7 qt)
Cooling System	Air Cooled
Air Cleaner	Paper with outer foam element
Muffler	Horizontal discharge below frame



REPAIR SPECIFICATIONS

Spark Plug Gap 0.76 mm (0.030 in.)

Valves:

Valve Guide Standard Dimension	6.01 – 6.02 mm (0.236 – 0.237 in.)
Wear Limit	6.05 mm (0.238 in.)
Valve Stem Standard Dimension	
Intake	5.94 – 5.96 mm (0.234 – 0.235 in.)
Exhaust	5.94 – 5.95 mm (0.234 – 0.235 in.)
Valve stem Wear Limit	
Intake	5.92mm (0.233 in.)
Exhaust	5.91mm (2.328 in.)
Valve Seat Width	1.2 – 1.6 mm (0.047 – 0.062 in.)
Valve Margin (Min)	0.4 mm (0.016 in.)
Valve Face Angle	45°
Valve Seat Narrowing Angle	30°

Cylinder Bore, Pistons and Rings:

Cylinder Bore Standard Dimension	72 – 72.02mm (2.835 – 2.836 in.)
Wear Limit	72.16 mm (2.839 in.)
Piston Pin Standard Dimension	17.07 – 17.08 mm (0.672 – 0.673 in.)
Wear Limit	17.06 mm (0.672 in.)
Piston Pin Bore Standard Dimension	17.09 – 17.1 mm (0.673 – 0.674 in.)
Wear Limit	17.12 mm (0.674 in.)
Ring End Gap Standard Dimension	0.20 – 0.40 mm (0.008 – 0.016 in.)
Wear Limit	0.76 mm (0.030 in.)
Compression Ring Groove Wear Limit (New Ring Installed)	0.10 mm (0.004 in.)
Oil Ring Groove Clearance Wear Limit (New Ring Installed)	0.20 mm (0.008 in.)

Connecting Rod and Crankshaft:

Connecting Rod Crankpin Standard Dimension . . .	37.06 – 37.08 mm (1.459 – 1.460 in.)
Wear Limit	37.12 mm (1.461 in.)
Connecting Rod Piston Pin Bearing Std. Dimension	17.09 – 17.1 mm (0.672 – 0.673 in.)
Wear Limit	17.12 mm (0.674 in.)
Crankshaft PTO Journal Standard Dimension . . .	34.96 – 34.97 mm (1.376 – 1.377 in.)
Wear Limit	34.92 mm (1.375 in.)
Crankshaft Magneto Journal Standard Dimension	34.99 – 35.01 mm (1.377 – 1.378 in.)
Wear Limit	34.95 mm (1.376 in.)
Magneto Bearing Standard Dimension	35.02 – 35.06 mm (1.379 – 1.3805 in.)
Wear Limit	35.12 mm (1.383 in.)
PTO Bearing Standard Dimension	35.04 – 35.05 mm (1.379 – 1.380 in.)
Wear Limit	35.07 mm (1.381 in.)
Crankshaft Crankpin Journal Standard Dimension .	37.0 – 37.02 mm (1.456 – 1.457 in.)
Wear Limit	36.95 mm (1.455 in.)
Crankshaft End Play	0.08 – 0.40 mm (0.003 – 0.015 in.)
Cam Gear PTO Journal Standard Dimension. . . .	19.94 – 19.96 mm (0.785 – 0.786 in.)
Wear Limit	19.92 mm (0.784 in.)
Cam Gear Magneto Journal Standard Dimension	15.95 – 15.97 mm (0.628 – 0.629 in.)
Wear Limit	15.93 mm (0.627 in.)
Cam Lobe Standard Dimension	30.33 – 30.53 mm (1.194 – 1.202 in.)
Wear Limit	30.25 mm (1.191 in.)
Cam Bearing (Magneto Side) Standard Dimension	16.0 – 16.025 mm (0.630 – 0.631 in.)
Wear Limit	16.08 mm (0.633 in.)
Cam Bearing (PTO Side) Standard Dimension. . .	20.0 – 20.02 mm (0.787 – 0.788 in.)
Wear Limit	20.04 mm (0.789 in.)



TORQUE SPECIFICATIONS

Alternator to Cylinder Block.	2.2 Nm (20 lb in.)
Air Cleaner Base to Carburetor	7 N•m (65 lb-in.)
Connecting Rod Cap Screws	13 N•m (115 lb-in.)
Crankcase Cover.	17 N•m (150 lb-in.)
Cylinder Head Cap Screws	19 N•m (165 lb-in.)
Cylinder Shield	7 N•m (65 lb-in.)
Exhaust Manifold.	17 N•m (150 lb-in.)
Flywheel Nut	175 N•m (125 lb-ft)
Fuel Shutoff Solenoid	5 N•m (45 lb-in.)
Oil Breather Mounting Bolt	3 N•m (30 lb-in.)
Oil Filter Adaptor Mounting Bolts	7 N•m (65 lb-in.)
Oil Pump Mounting Screws.	7 N•m (65 lb-in.)
Rocker Arm Adjustment Lock Nut	7 N•m (65 lb-in.)
Rocker Arm Studs	11 N•m (100 lb-in.)
Spark Plug.	20 N•m (180 lb-in.)
Valve Cover Nuts.	3 N•m (25 lb-in.)

TESTS & ADJUSTMENTS SPECIFICATIONS

Valve Clearance	0.10 – 0.16 mm (0.004 – 0.006 in.)
Valve Guide Depth	0.7 mm (0.281 in.)
Slow Idle	1750 ± 50 rpm
Fast Idle.	3600 ± 50 rpm
Oil Pump Operating Pressure	10—50 psi

SPECIFICATIONS—BRIGGS & STRATTON 16.40 kW (22.0 hp)

GENERAL SPECIFICATIONS

Make	Briggs & Stratton
Series	Vanguard V-Twin
Type	0131-E1 Gasoline
Model	380777
Horsepower	14.4 kW (22.0 hp)
Cylinders	2
Displacement	627 cc (38.2 cu. in.)
Stroke/Cycle	4
Bore	72 mm (2.83 in.)
Stroke	77.21 mm (3.04 in.)
Valving	Overhead Valves
Lubrication	Pressurized
Oil Filter	Full Flow Filter (w/o By-Pass Valve)
Oil Capacity	
w/o oil filter	1.42 L (1.5 qt)
w/ oil filter	1.65 L (1.7 qt)
Cooling System	Air Cooled
Air Cleaner	Paper with outer foam element
Muffler	Horizontal discharge below frame



REPAIR SPECIFICATIONS

Spark Plug Gap0.76 mm (0.030 in.)

Valves:

Valve Guide Standard Dimension	6.01 – 6.02 mm (0.236 – 0.237 in.)
Wear Limit	6.05 mm (0.238 in.)
Valve Stem Standard Dimension	
Intake	5.94 – 5.96 mm (0.234 – 0.235 in.)
Exhaust	5.94 – 5.95 mm (0.234 – 0.235 in.)
Valve stem Wear Limit	
Intake	5.92mm (0.233 in.)
Exhaust	5.91mm (2.328 in.)
Valve Seat Width	1.2 – 1.6 mm (0.047 – 0.062 in.)
Valve Margin (Min)	0.4 mm (0.016 in.)
Valve Face Angle	45°
Valve Seat Narrowing Angle	30°

Cylinder Bore, Pistons and Rings:

Cylinder Bore Standard Dimension	72 – 72.02mm (2.835 – 2.836 in.)
Wear Limit	72.16 mm (2.839 in.)
Piston Pin Standard Dimension	17.07 – 17.08 mm (0.672 – 0.673 in.)
Wear Limit	17.06 mm (0.672 in.)
Piston Pin Bore Standard Dimension	17.09 – 17.1 mm (0.673 – 0.674 in.)
Wear Limit	17.12 mm (0.674 in.)
Ring End Gap Standard Dimension	0.20 – 0.40 mm (0.008 – 0.016 in.)
Wear Limit	0.76 mm (0.030 in.)
Compression Ring Groove Wear Limit (New Ring Installed)	0.10 mm (0.004 in.)
Oil Ring Groove Clearance Wear Limit (New Ring Installed)	0.20 mm (0.008 in.)

Connecting Rod and Crankshaft:

Connecting Rod Crankpin Standard Dimension . . .	37.06 – 37.08 mm (1.459 – 1.460 in.)
Wear Limit	37.12 mm (1.461 in.)
Connecting Rod Piston Pin Bearing Std. Dimension	17.09 – 17.1 mm (0.672 – 0.673 in.)
Wear Limit	17.12 mm (0.674 in.)
Crankshaft PTO Journal Standard Dimension . . .	34.96 – 34.97 mm (1.376 – 1.377 in.)
Wear Limit	34.92 mm (1.375 in.)
Crankshaft Magneto Journal Standard Dimension	34.99 – 35.01 mm (1.377 – 1.378 in.)
Wear Limit	34.95 mm (1.376 in.)
Magneto Bearing Standard Dimension	35.02 – 35.06 mm (1.379 – 1.3805 in.)
Wear Limit	35.12 mm (1.383 in.)
PTO Bearing Standard Dimension	35.04 – 35.05 mm (1.379 – 1.380 in.)
Wear Limit	35.07 mm (1.381 in.)
Crankshaft Crankpin Journal Standard Dimension .	37.0 – 37.02 mm (1.456 – 1.457 in.)
Wear Limit	36.95 mm (1.455 in.)
Crankshaft End Play	0.08 – 0.40 mm (0.003 – 0.015 in.)
Cam Gear PTO Journal Standard Dimension	19.94 – 19.96 mm (0.785 – 0.786 in.)
Wear Limit	19.92 mm (0.784 in.)
Cam Gear Magneto Journal Standard Dimension	15.95 – 15.97 mm (0.628 – 0.629 in.)
Wear Limit	15.93 mm (0.627 in.)
Cam Lobe Standard Dimension	30.33 – 30.53 mm (1.194 – 1.202 in.)
Wear Limit	30.25 mm (1.191 in.)
Cam Bearing (Magneto Side) Standard Dimension	16.0 – 16.025 mm (0.630 – 0.631 in.)
Wear Limit	16.08 mm (0.633 in.)
Cam Bearing (PTO Side) Standard Dimension . . .	20.0 – 20.02 mm (0.787 – 0.788 in.)
Wear Limit	20.04 mm (0.789 in.)





TORQUE SPECIFICATIONS

Alternator to Cylinder Block	2.2 Nm (20 lb in.)
Air Cleaner Base to Carburetor	7 N•m (65 lb-in.)
Connecting Rod Cap Screws	13 N•m (115 lb-in.)
Crankcase Cover	17 N•m (150 lb-in.)
Cylinder Head Cap Screws	19 N•m (165 lb-in.)
Cylinder Shield	7 N•m (65 lb-in.)
Exhaust Manifold	17 N•m (150 lb-in.)
Flywheel Nut	175 N•m (125 lb-ft)
Fuel Shutoff Solenoid	5 N•m (45 lb-in.)
Oil Breather Mounting Bolt	3 N•m (30 lb-in.)
Oil Filter Adaptor Mounting Bolts	7 N•m (65 lb-in.)
Oil Pump Mounting Screws	7 N•m (65 lb-in.)
Rocker Arm Adjustment Lock Nut	7 N•m (65 lb-in.)
Rocker Arm Studs	11 N•m (100 lb-in.)
Spark Plug	20 N•m (180 lb-in.)
Valve Cover Nuts	3 N•m (25 lb-in.)

TESTS & ADJUSTMENTS SPECIFICATIONS

Valve Clearance	0.10 – 0.16 mm (0.004 – 0.006 in.)
Valve Guide Depth	0.7 mm (0.281 in.)
Slow Idle	1750 ± 50 rpm
Fast Idle	3600 ± 50 rpm
Oil Pump Operating Pressure	10—50 psi

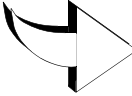
TROUBLESHOOTING

<div style="text-align: center;"> Problem or Symptom  </div> <div style="text-align: center;"> Check or Solution  </div>	Engine will not crank	Engine cranks but will not start	Engine starts hard	Engine won't shutoff	Loss of power	Low compression	Excessive engine noise/vibration	Low oil pressure	Engine running on one cylinder	Engine overheats	Fuel mixture too rich
Battery has low or no charge/cables loose or dirty	●	●	●								
Fusible link (F2) or fuse (F1) open	●										
Starter motor/solenoid defective	●										
Improper switch position (See Electrical Section)	●	●									
Engine seized	●										
Fuel shutoff solenoid defective		●		●							
Fuel filter/lines clogged		●	●		●						
Fuel pump defective		●	●		●						
Ignition coil air gap not adjusted properly		●	●		●				●		
Carburetor not adjusted properly, dirty		●	●	●	●					●	●
Air cleaner dirty		●	●		●						●
Old/contaminated fuel		●	●		●						
Spark plugs loose/dirty		●	●		●	●			●		
Magneto kill circuit grounded/shorted (See Electrical Section)		●							●		
Valve tappets need adjustment		●	●		●	●			●		
Lack of compression, check valves, pistons and rings		●	●		●				●		
Magneto kill circuit open (See Electrical Section)				●							
Mower deck binding or dragging					●		●			●	
Grass buildup under deck					●		●			●	
No lubrication in gear box or hydro/transaxle					●		●			●	
Excessive drive belt tension										●	
Deck spindles seized					●		●			●	
Loose cylinder head bolts						●			●		
Defective head gasket						●			●		
Burned valves, valve seats, and/or loose valve seats		●	●		●	●			●		



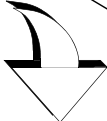
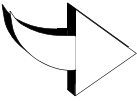

<div style="display: flex; justify-content: space-between;"> <div style="text-align: center;"> Check or Solution  </div> <div style="text-align: center;"> Problem or Symptom  </div> </div>	Engine will not crank	Engine cranks but will not start	Engine starts hard	Engine won't shutoff	Loss of power	Low compression	Excessive engine noise/vibration	Low oil pressure	Engine running on one cylinder	Engine overheats	Fuel mixture too rich
Warped cylinder head			●		●	●			●		
Worn bore and/or rings			●		●	●	●		●		
Broken connecting rod			●		●	●	●		●		
Cutter blade or other rotating part bent or out of balance							●				
Mounting bolts loose							●				
Camshaft worn		●	●		●	●			●		
Internal bearings worn or excessive tolerance								●			
Oil galleries/filter clogged								●			
Oil pump defective								●			
Low oil level or wrong viscosity								●		●	
Exhaust system restricted			●		●					●	
Air/fuel mixture excessively lean										●	
Cylinder cooling fins/blower housing filled with grass clippings										●	
Overchoking											●
Float needle stuck open											●

ENGINE TROUBLESHOOTING GUIDE

Engine Will Not Crank

NOTE: To test specific electrical components, see Electrical Section and refer to either Diagnostics or Tests & Adjustments for further guidance.



⚠ CAUTION

BE AWARE! The engine may start to rotate at any time. Keep hands away from all moving parts when testing.

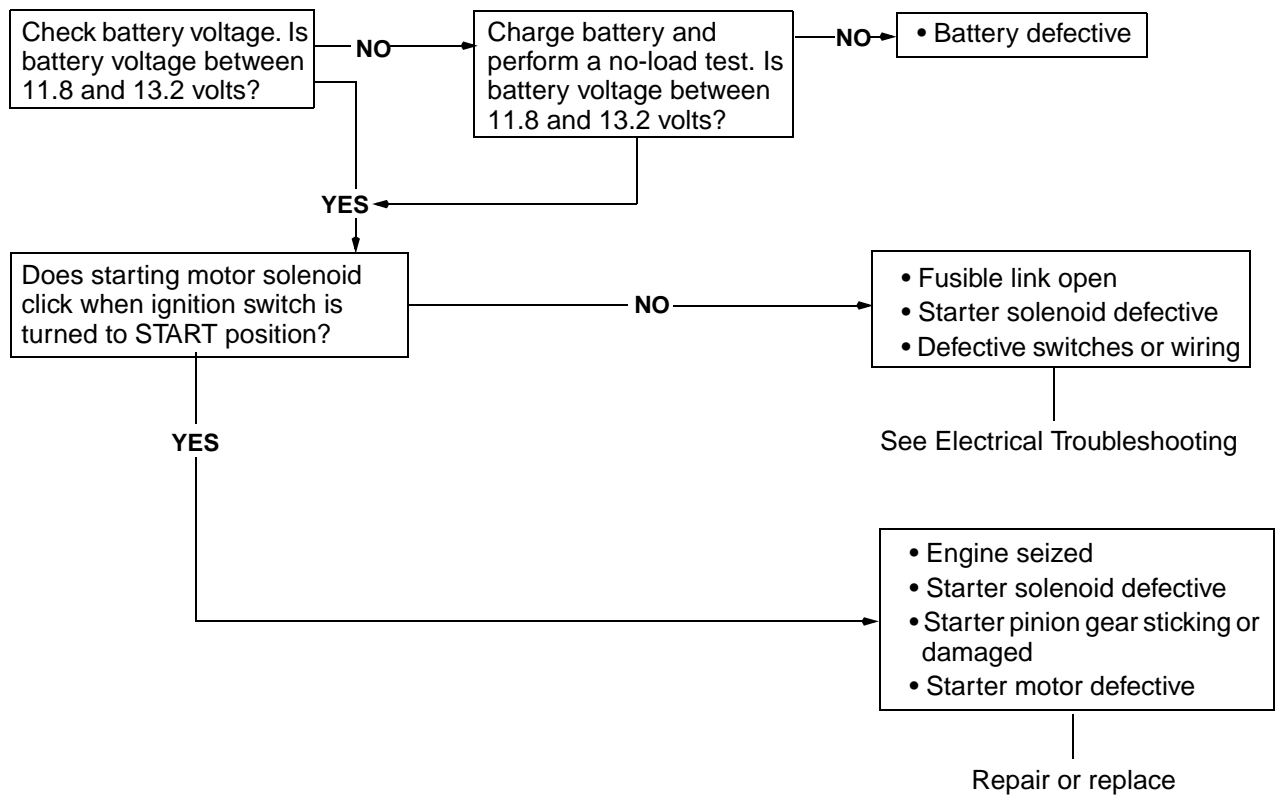

Engine Cranks But Will Not Start

CAUTION

DO NOT rotate engine with starting motor if the spark plugs are removed. Gasoline spray from the open cylinders may be ignited by ignition spark and cause an explosion or fire.

IMPORTANT: Perform a visual inspection first to determine if battery cables are tight and not corroded and if the battery is of sufficient size to turn the engine over at minimum cranking speed of 350 rpm.

NOTE: To test specific electrical components, see *Electrical Section* and refer to either *Diagnostics* or *Tests & Adjustments* for further guidance.

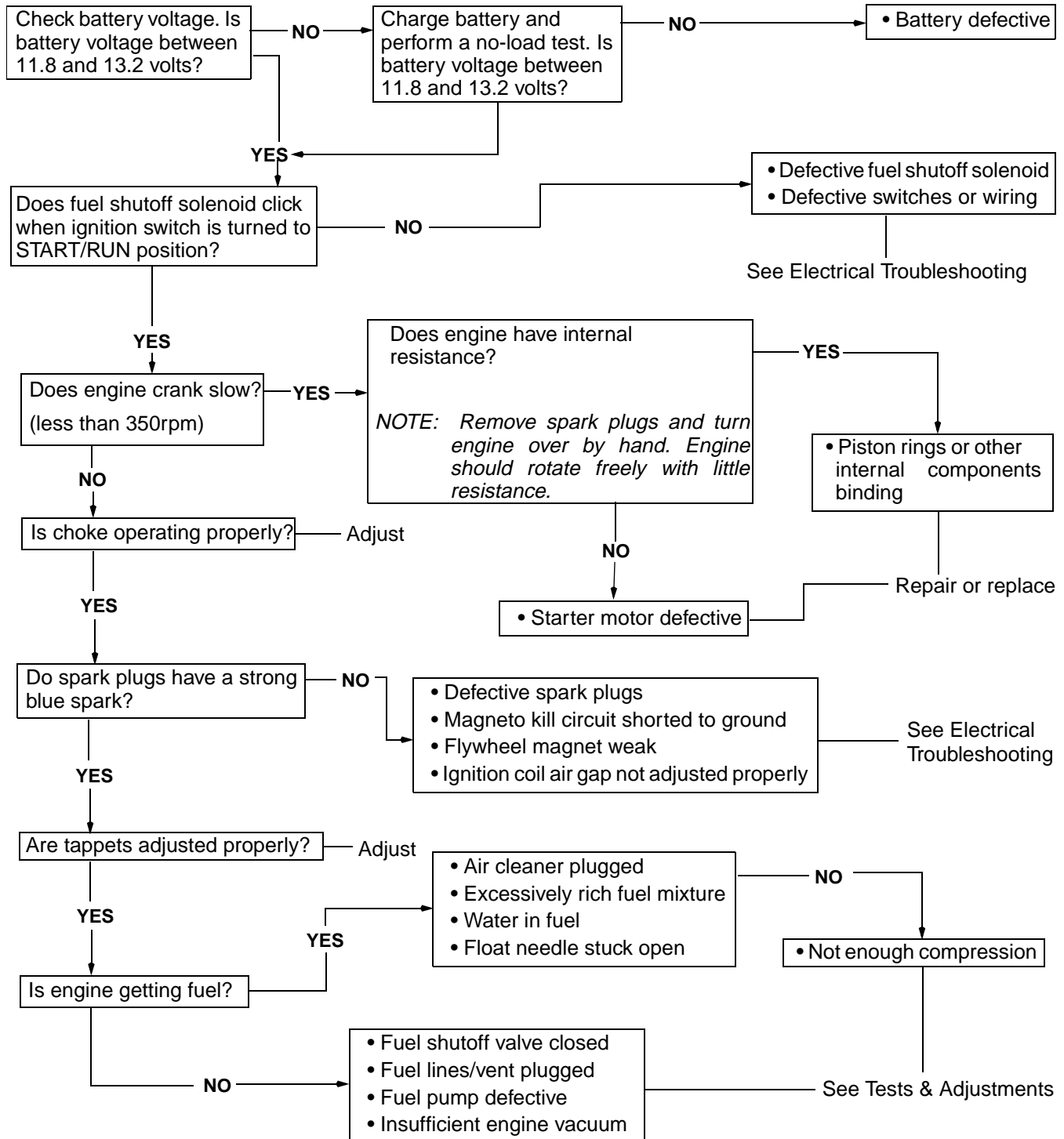

Engine Runs Erratically/Loss Of Power

IMPORTANT: Before proceeding, inspect the mower deck and belts for binding in the spindle assemblies or belts that are too tight/loose. A loose belt like a loose blade can cause a backlash effect that will counteract engine cranking effort. Excessive drive belt tension may cause premature bearing wear or result in bearing seizure. Grass clippings that build up near the cutting blades can cause excessive resistance and heat buildup that causes problems with the engine's ability to turn the blades at a constant speed. Low lubricant levels in the spindles will buildup heat causing excessive resistance for the engine to deal with.

There is a diode in-line in the magneto kill wire coming from each ignition module. This diode prevents feedback from one module to the other. Without these diodes, one magneto could fire the coil for the other magneto. If a diode fails in one of the magneto kill wires, that coil, could be fired by the other module, the result may be similar to that of an erratic running engine.

A twin cylinder engine may run adequately on one cylinder as long as the power required for the application does not exceed the power produced by the one cylinder.



NOTE: To test specific electrical components, see Electrical Section and refer to either Diagnostics or Tests & Adjustments for further guidance.

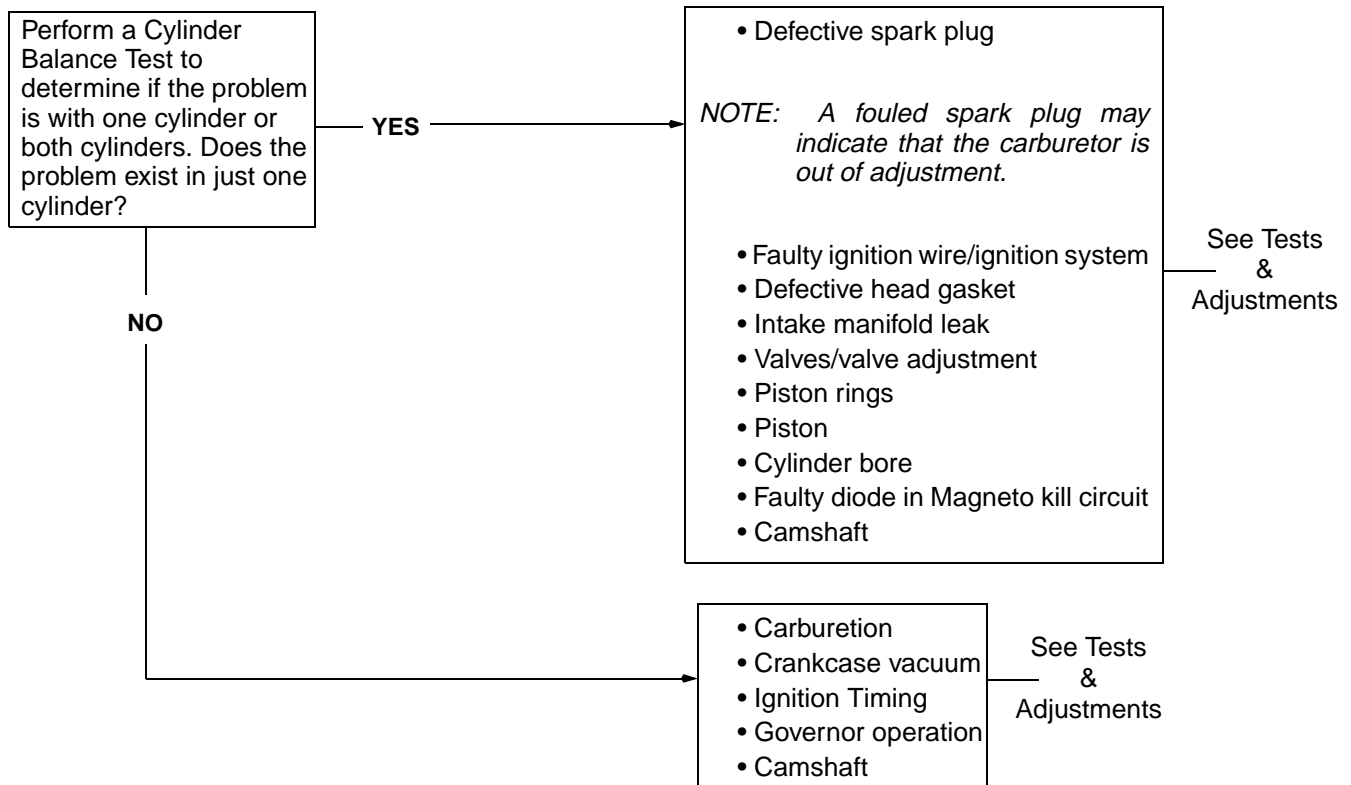

TESTS & ADJUSTMENTS

THROTTLE CABLE ADJUSTMENT

Reason:

To make sure the throttle cable moves the throttle through its full range of movement.

Procedure:

1. Remove air cleaner assembly, and base. (See "AIR CLEANER REMOVAL AND INSTALLATION" on page 19.)

NOTE: Nuts securing air cleaner base to carburetor also secure carburetor to intake manifold. DO NOT run engine with nuts removed.

2. Install nuts on carburetor studs.
3. Move throttle lever to FAST idle position.

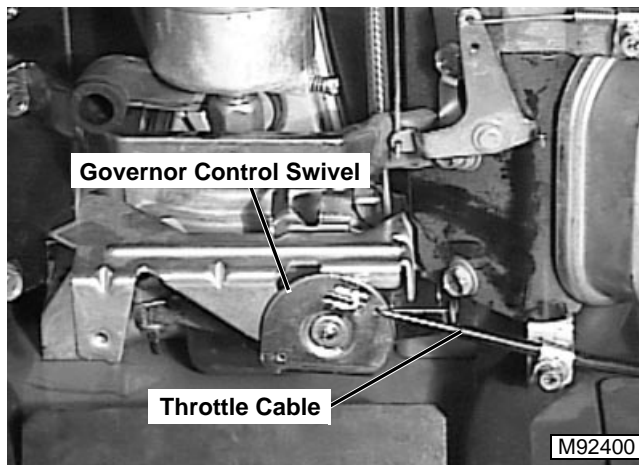

4. Loosen throttle cable clamp.
5. Move throttle cable until governor control swivel is at end of travel.
6. Tighten throttle cable clamp.

CHOKE CABLE ADJUSTMENT

Reason:

To make sure the choke cable moves the choke through its full range of movement.

Procedure:

1. Pull choke knob to full choke position.

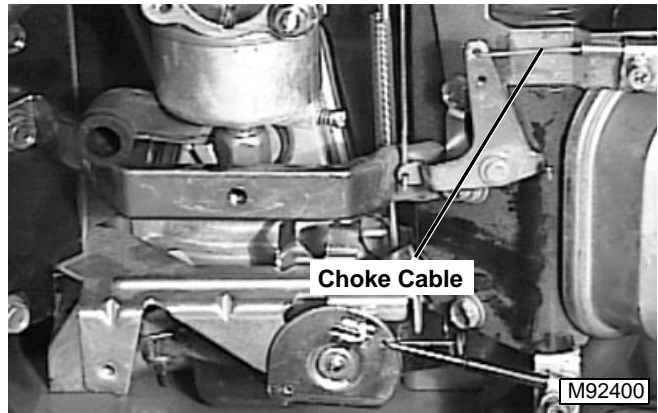

2. Loosen choke cable clamp.
3. Move choke cable until choke is completely closed.
4. Tighten choke cable clamp.
5. Push choke knob in and make sure choke is opening completely. Readjust if necessary.

FUEL SHUTOFF SOLENOID TEST

Reason:

To test proper operation of fuel shutoff solenoid.

Required Tools:

- Jumper wire

Procedure:

1. Listen for an audible click when ignition switch is turned from OFF to ON.
2. If solenoid does not click, problem could be in equipment wiring.

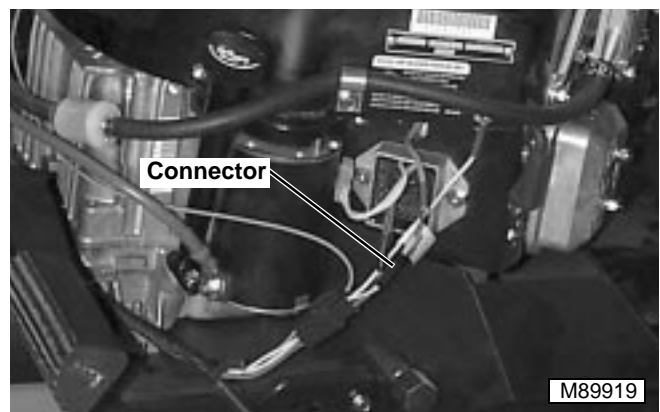

3. Disconnect wire connector to fuel solenoid.
4. Momentarily place a jumper wire from solenoid wire to battery positive terminal.

- If solenoid now clicks, the solenoid is working properly.

NOTE: If battery voltage drops below 9 volts when cranking engine or while engine is running, the solenoid will not function.

Results:

- Solenoid is operating properly if a click is heard when ignition switched from off to on

COMPRESSION TEST

Reason:

To determine the performance difference between cylinders.

Required Tools:

- JDM59 Compression Gauge

NOTE: Briggs & Stratton does not publish any compression pressures, as it is extremely difficult to obtain an accurate reading without special equipment. What is recommended is to calculate the difference in compression readings between the two cylinders. Two methods are given in the following; one without a cylinder leak tester and one with a cylinder leak tester.

WITHOUT CYLINDER LEAK TESTER

IMPORTANT: The battery must be fully charged for this test.

Check and adjust the valves to ensure the valves have not been adjusted too tight. If either valve is off its seat the leak test will be invalid.

- Remove spark plugs and ground the magnetos by attaching a jumper wire from the magneto kill circuit connector to the engine to prevent a spark that could ignite anything combustible.

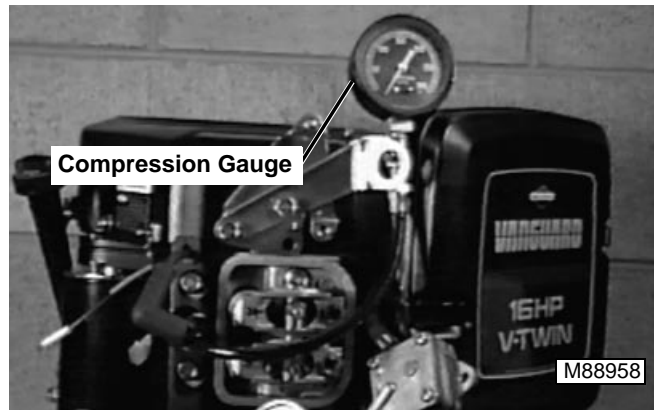

- Insert a compression gauge into either cylinder.
- Turn engine over with the starting motor until the highest pressure reading is obtained and record reading.
- Repeat steps 3 & 4 with the next cylinder and record reading.
- Use the following example and insert the recorded readings to determine the percent of leakage between cylinders.

Example:

cyl #1	cyl #2
75 psi	55 psi

Formula:

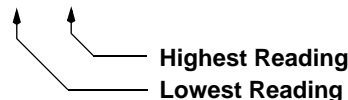
$$55 \div 75 = 0.7333 \times 100 = 73.333, 100 - 73.333 = \underline{26.7\%}$$

Results:

- A difference of more than 25% indicates a loss of compression in the cylinder with the lowest reading.

WITH CYLINDER LEAK TESTER

Required Tools:

- JTO3502 Cylinder Leak Tester
- Breaker Bar & 30 mm Socket

NOTE: If the directions that come with the tester being used are different than the following, use the directions that came with the tester.

IMPORTANT: Check and adjust the valves to ensure the valves have not been adjusted too tight. If either valve is off its seat the leak test will be invalid.

1. The engine should be run for at least 5 minutes to bring the engine to operating temperature.



CAUTION

With spark plugs removed, the magnetos must be grounded to the engine to prevent a spark that could ignite anything combustible.

2. Remove spark plugs and ground the magnetos by attaching a jumper wire from the magneto kill circuit connector to the engine to prevent a spark that could ignite anything combustible.

IMPORTANT: The piston must be positioned at Top Dead Center (TDC) to ensure that the intake valves are away from the compression relief balls. If not, the intake valve will be open and the leak test will be invalid.

3. Remove valve covers.
4. Remove the rotating screen.
5. Turn crankshaft until piston is at Top Dead Center (TDC), on the compression stroke (Both Valves Closed).
6. Screw the adaptor into the spark plug hole but do not attach it to the tester at this time.

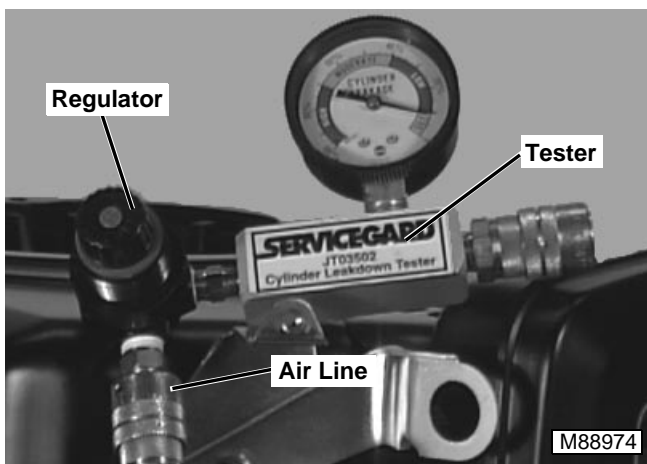

7. Pull back the locking ring and rotate the regulator knob fully counterclockwise. Connect an air line to the tester.

IMPORTANT: The air supply must have enough supply pressure to calibrate the tester (Usually 85—95 psi).

8. Pull back the locking ring and rotate the regulator knob clockwise until the gauge needle rests in the SET range of the gauge. Push the locking ring towards the tester to lock it.

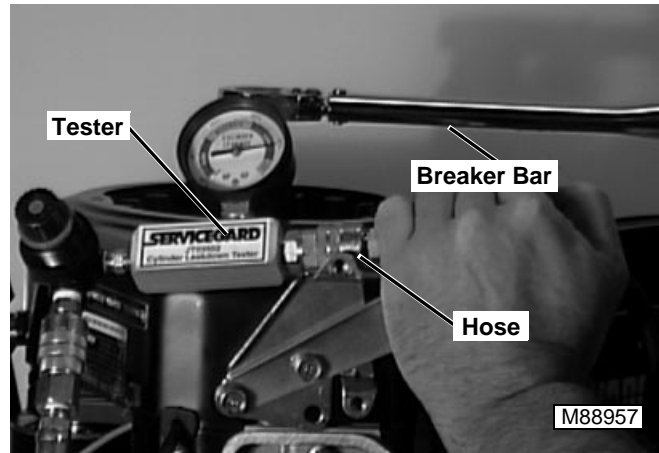

9. Connect the adaptor hose to the tester and record the needle position while holding the flywheel in position with a breaker bar.

NOTE: A small amount of air escaping from the crankcase breather is normal.

Results:

- Excessive air escaping from the crankcase breather indicates worn piston rings or cylinder wall
- Air escaping from the carburetor indicates a worn intake valve or seat
- Air escaping from the exhaust pipe indicates a worn exhaust valve or seat
- Gauge reading in the Green (low) area indicates good compression. (Less Than 25% Is Considered Normal)
- Gauge reading in the Yellow (Moderate) area indicates borderline compression. The engine is still usable but an overhaul or replacement should be considered
- Gauge reading in the Red (High) area indicates excessive compression loss and engine reconditioning or replacement is necessary



Suggest:

If the above button click is invalid.

Please download this document

first, and then click the above link

to download the complete manual.

Thank you so much for reading

CARBURETOR ADJUSTMENT

Reason:

To set the carburetor mixture screws for proper operation of the carburetor.

ATTENTION!

DO NOT attempt to disassemble or adjust the engine CARB/EPA Certified Emissions Carburetor unless you are a factory trained technician with authorization to service CARB/EPA Certified Emissions Carburetors.

Equipment:

- Pulse Tachometer # JT07270

IMPORTANT: In order to obtain correct operation of the carburetor, the adjustment procedure must be performed in the sequence shown.

INITIAL ADJUSTMENT

Procedure:

1. Remove air cleaner assembly, and base. (See "AIR CLEANER REMOVAL AND INSTALLATION" on page 19.)

NOTE: Nuts securing air cleaner base to carburetor also secure carburetor to intake manifold. DO NOT run engine with nuts removed.

2. Install nuts on carburetor studs.
3. Remove limiter cap.
4. Turn idle mixture screw clockwise until it just seats. DO NOT FORCE.
5. Turn screw 1 ¼ turns counter-clockwise. This setting will allow the engine to start.

FINAL ADJUSTMENT

NOTE: All carburetor adjustments with engine running must be made with the air cleaner installed.

6. Install air cleaner base and air cleaner.
7. Start and run engine for 5 minutes to allow engine to reach operating temperature.
8. Move throttle lever to SLOW idle position.

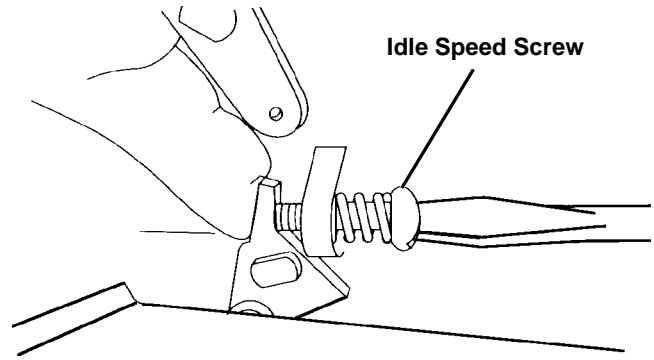

M92399

9. Install pulse tachometer.

10. Hold throttle lever against idle speed screw and temporarily adjust idle speed to 1400 rpm.

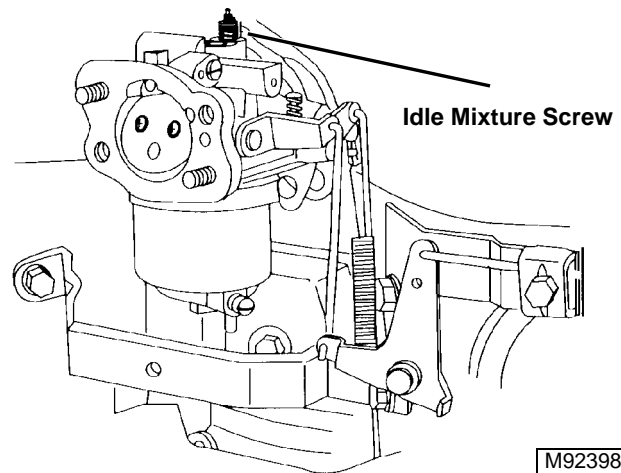

M92398

11. Turn idle mixture screw slowly clockwise until engine speed just starts to slow (Lean Mixture).
12. Turn idle mixture screw slowly counter-clockwise until engine speed just starts to slow (Rich Mixture).
13. Turn screw to the midpoint between rich and lean settings.
14. Hold throttle lever against idle speed adjustment screw and readjust idle speed to **1200 rpm**.
15. Release throttle lever and note rpm.

<https://www.ebooklibonline.com>

Hello dear friend!

Thank you very much for reading.

Enter the link into your browser.

The full manual is available for immediate download.

<https://www.ebooklibonline.com>