

John Deere 1530 Tractor



JOHN DEERE

TECHNICAL MANUAL

John Deere
1530 Tractor

TM4280 (01Mar73) English

John Deere Waterloo Works
TM4280 (01Mar73)

LITHO IN U.S.A.
ENGLISH



CONTENTS

SECTION 10 — GENERAL

- Group 5 - Specifications
- Group 10 - Pre-delivery, delivery and after-sales inspections
- Group 15 - Lubrication and periodic service
- Group 20 - Engine and tractor tune-up
- Group 25 - Tractor separation

SECTION 20 — ENGINE

- Group 5 - General information, diagnosing malfunctions
- Group 10 - Cylinder head and camshaft
- Group 15 - Cylinder block, liners, pistons and connecting rods
- Group 20 - Crankshaft, main bearings and flywheel
- Group 25 - Timing gear train
- Group 30 - Oil pump, oil pressure regulating valve and oil filter
- Group 35 - Engine cooling system
- Group 40 - Speed control linkage

SECTION 30 — FUEL SYSTEM

- Group 5 - Diagnosing malfunctions
- Group 10 - Fuel tank, transfer pump, fuel filter
- Group 15 - Fuel injection pumps
- Group 20 - Injection nozzles
- Group 25 - Cold weather starting aid

SECTION 40 — ELECTRICAL SYSTEM

- Group 5 - Diagnosing malfunctions
- Group 10 - Components and wiring diagram
- Group 15 - Bosch starting motor
- Group 17 - Delco-Remy starting motor
- Group 20 - Bosch alternator and regulator
- Group 22 - Motorola alternator and regulator

SECTION 50 — POWER TRAIN

- Group 5 - Engine clutches and clutch linkage
- Group 10 - Hi-Lo shift unit
- Group 15 - Collar-shift transmission
- Group 20 - Differential
- Group 25 - Final drives
- Group 30 - Continuous-running PTO
- Group 35 - Independent PTO

SECTION 60 — FRONT AXLE, STEERING SYSTEM AND BRAKES

- Group 5 - Front axle
- Group 10 - Steering system
- Group 15 - Hydraulic brakes

SECTION 70 — HYDRAULIC SYSTEM

- Group 5 - General information, diagnosing malfunctions and tests
- Group 10 - Oil reservoir, filter, valves and oil cooler
- Group 15 - Hydraulic pump and transmission oil pump
- Group 20 - Rockshaft
- Group 25 - Selective control valve and breakaway coupler
- Group 30 - Remote cylinder

SECTION 80 — MISCELLANEOUS

- Group 5 - Belt pulley
- Group 10 - DE LUXE seat
- Group 15 - Front and rear wheels

INTRODUCTION

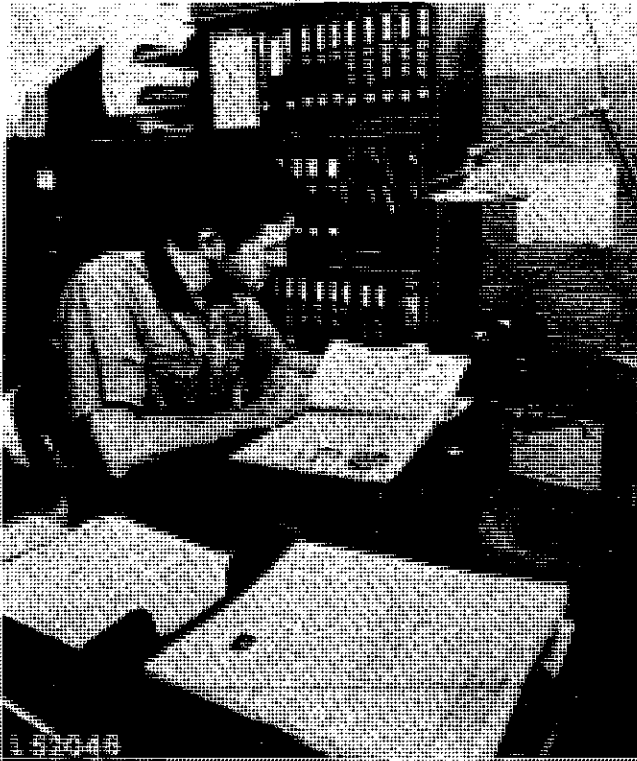

Use FOS Manuals for Reference

This technical manual is part of a twin concept of service:

- FOS Manuals – for reference
- Technical Manuals – for actual service

The two kinds of manuals work as a team to give you both the general background and technical details of shop service.

Fundamentals of Service (FOS) Manuals cover basic theory of operation, fundamentals of trouble shooting, general maintenance, and basic types of failures and their causes. FOS Manuals are for training new men and for reference by experienced men.

Technical Manuals are concise service guides for a specific machine. Technical Manuals are on-the-job guides containing only the vital information needed by a journeyman mechanic.



When a serviceman should refer to a FOS Manual for more information, a FOS symbol like the one at the left is used in the TM to identify the reference.

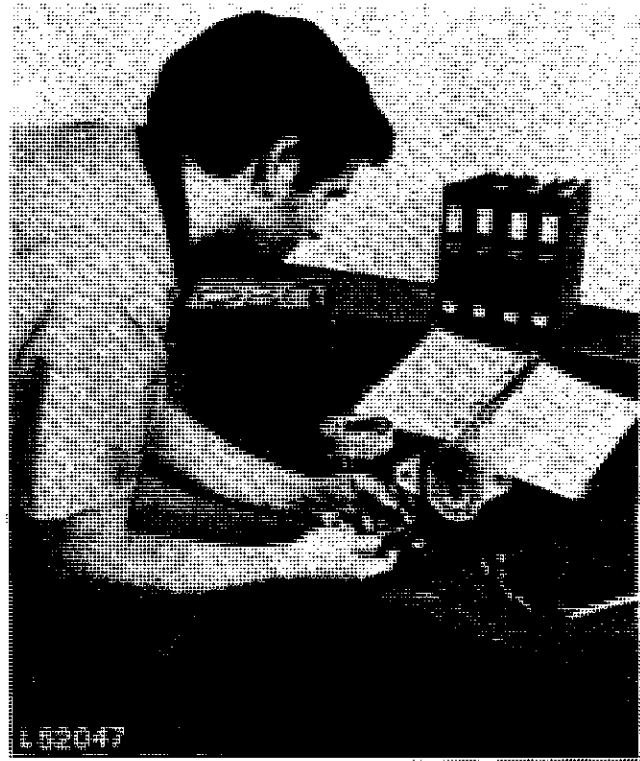

Use Technical Manuals for Actual Service

Some features of this technical manual:

- *Table of contents at front of whole Manual.*
- *Contents at front of each Section*
- *Exploded views showing parts relationship*
- *Photos showing service techniques*
- *Specifications at end of each Group*
- *Special tools at end of each Group*

This technical manual was planned and written for you—a journeyman mechanic. Keep it in a permanent binder in the shop where it is handy. Refer to it whenever in doubt about correct service procedures or specifications.

Using the technical manual as a guide will reduce error and costly delay. It will also assure you the best in finished service work.



This safety alert symbol indicates important safety messages in this manual. When you see this symbol, be alert to the possibility of personal injury and carefully read the message that follows.

<https://www.ebooklibonline.com>

Hello dear friend!

Thank you very much for reading.

Enter the link into your browser.

The full manual is available for immediate download.

<https://www.ebooklibonline.com>

Section 10 GENERAL

CONTENTS OF THIS SECTION

GROUP 5 — SPECIFICATIONS

	Page
Serial numbers	5-2
Model numbers	5-2
Engine	5-2
Engine clutch	5-2
Electrical system	5-2
Transmission	5-3
Hi-Lo shift unit	5-3
Differential and final drives	5-3
Differential lock	5-3
PTO	5-3
Hydraulic system	5-3
Power steering	5-3
Manual steering	5-3
Hydraulic brakes	5-3
Capacities	5-3
Travel speeds	5-3
Front and rear wheels	5-3
Dimensions and weights	5-3

GROUP 10 — PREDELIVERY, DELIVERY AND AFTER-SALES INSPEC- TIONS

Predelivery inspection	10-1
Delivery inspection	10-4
After-sales inspection	10-4

GROUP 15 — LUBRICATION AND PERIODIC SERVICE

	Page
Lubrication and periodic service	15-1

GROUP 20 — ENGINE AND TRACTOR TUNE-UP

General information	20-1
Preliminary engine testing	20-1
Engine tune-up	20-2
Checking engine performance	20-3
Tractor tune up	20-3
Standard torques	20-5

GROUP 25 — TRACTOR SEPARATION

Separating between engine and tractor front end	25-1
Removing and installing engine	25-3
Removal and installation of clutch housing	25-5
Removal and installation of final drives	25-7
Removal and installation of rockshaft	25-8
Torques for hardware	25-9
Special tools	25-10

Group 5

SPECIFICATIONS

SERIAL NUMBERS

The engine serial number is stamped into the name plate at the lower right of the front cylinder block.

NOTE: If ordering engine parts, indicate all digits of the serial number on the name plate.

The name plate showing the tractor serial number is located on the right-hand side of the front support.

NOTE: If ordering tractor parts, (excluding engine parts), indicate all digits of the serial number on the name plate.

MODEL NUMBERS

The injection pump, injection nozzles, the alternator, starter and the hydraulic pump have model numbers to facilitate identification of different makes of a given unit.

SPECIFICATIONS

ENGINE

Number of cylinders	3
Cylinder liner bore	102 mm (4.02 in.)
Stroke	110 mm (4.33 in.)
Displacement	2690 cm ³ (164 cu.in.)
Compression ratio	16.2 : 1
Maximum torque at 1500 rpm	17.0 mkp (123 ft.lbs.)
Firing order	1 - 2 - 3
Valve clearance (engine hot or cold)	
Intake valve	0.35 mm (0.014 in.)
Exhaust valve	0.45 mm (0.018 in.)

Fast idle	2650 rpm
Slow idle	650 rpm
Working speed range	1500 to 2500 rpm
PTO power* (at 2500 rpm engine speed and 650 rpm powershaft speed)	46 HP (34.3 kw)

ENGINE CLUTCH

Dual dry disk clutch, foot-operated

Single dry disk clutch with torsion damper (isolator), foot-operated (on tractors with independent PTO)

ELECTRICAL SYSTEM

Batteries	2 x 12 volts, 55 ampere-hours
or	1 x 12 volts, 70 ampere-hours
Starter	12 volts, 4 HP
Alternator	14 volts, 28 amps.
Battery terminal grounded	negative

* With the engine run in (more than 100 hours of operation) and having reached operating temperature (engine and transmission); measured by means of a dynamometer. Permissible variation $\pm 5\%$.

TRANSMISSION

Type Collar shift

Gear selections 8 forward and 4 reverse

Shifting 4 speeds each in high, low, and reverse ranges. Park lock included.

HI-LO SHIFT UNIT

Hydraulically controlled reduction gear which can be shifted under load, with "wet" multiple disk clutch and "wet" multiple disk brake. Allows reduction of the individual gear speeds by 21 %.

DIFFERENTIAL AND FINAL DRIVES

Planetary reduction gear and differential with spiral bevel gears.

DIFFERENTIAL LOCK

Hand or foot operated; spring-loaded out of engagement.

PTO

Type Rear 540 rpm continuous-running or independent

Power Shaft Speeds

Engine Speed in rpm	PTO shaft speed in rpm
650	169
2067	538
2075	540
2500	650
2650	689

HYDRAULIC SYSTEM

Closed center, constant pressure system; also includes rockshaft, power steering and selective control valves.

Stand by oil pressure 156 to 160 kp/cm²
 (2220 to 2280 psi)

Pump 8-piston pump driven by the engine

POWER STEERING

The steering system is a "closed center" type incorporated by the hydraulic system and supplied with oil by the hydraulic pump. It is connected to the front wheels by means of a steering linkage.

MANUAL STEERING

The manual steering is a recirculating ball bearing, worm and nut type. A number of steel balls between ball nut and steering wheel shaft provide for positive engagement of steering wheel and steering linkage.

HYDRAULIC BRAKES

The disk brakes run in an oil bath and are hydraulically controlled.

CAPACITIES

	Ltr.	US.gals.	Imp.gals.
Fuel tank	62.5	16.5	13.75
Cooling system	10.5	2.75	2.3
Engine crankcase incl. filter	5.7	1.5	1.25
Transmission-hydraulic system			
Dry system	36.0	9.5	7.9
At service intervals	28.0	7.4	6.2
Belt pulley	1.1	0.3	0.25

TRAVEL SPEEDS

See Operator's Manual

FRONT AND REAR WHEELS

For tire sizes, treads, inflation pressure and weights see Operator's Manual.

DIMENSIONS AND WEIGHTS

See Operator's Manual.

Group 10

PREDELIVERY, DELIVERY AND AFTER-SALES INSPECTIONS

PREDELIVERY INSPECTION

Every new JOHN DEERE tractor leaves the factory in such a condition that it can be delivered to the customer after a minimum of service.

To promote complete customer satisfaction, proper predelivery service including mending of possible shipping damage and giving the finishing touches to the tractor, are of prime importance to the dealer.

A tag pointing out the factory-recommended procedure for predelivery service is attached to

every new tractor before it leaves the factory. The reverse side of this tag is filled in by the factory after the tractor has undergone a thorough inspection prior to shipping.

After completing the factory-recommended dealer checks and services listed on the predelivery tag, remove the tag from the tractor and file it with the shop order for the job. The tag will then serve as a basis for certifying that the unit has received the proper predelivery service.

TEMPORARY TRACTOR STORAGE

Service	Specifications	Reference
<p>Check radiator for coolant loss and antifreeze protection (gravity of anti-freeze and rust inhibitor mixture)</p> <p>IMPORTANT: When the tractor is delivered, red cable is not connected to alternator terminal "B+". Further, the alternator three-terminal plug is not connected. Connect cable and plug before operating tractor for the first time.</p> <p>If the tractor is to be operated for a short time without battery (using a slave battery for starting), do not, under any circumstances, interrupt the circuit by switching off the starter switch before stopping the engine by means of fuel pump shut off cable. Further, it is recommended to use additional current (lights) whilst engine is running. Insulating tape on battery cable end leading to starting motor should not be removed. If this advice is disregarded, damage to alternator and regulator may result.</p>	<p>Coolant level should be mid-way between radiator core and bottom edge of filler neck</p> <p>.....</p>	<p>Operator's manual</p> <p>Section 40, group 10</p>
<p>Remove batteries. Drain electrolyte and store batteries</p>	<p>Store at room temperature</p> <p>.....</p>	<p>.....</p>
<p>Reduce shipping pressure of tires</p>	<p>.....</p>	<p>Operator's manual</p>
<p>Cover tractor and tires for protection and cleanliness</p>	<p>.....</p>	<p>.....</p>

BEFORE DELIVERING TRACTOR

Service	Specifications	Reference
COOLING SYSTEM		
Check radiator for coolant loss	Coolant level should be midway between radiator core and bottom edge of filler neck.	Operator's manual
Check gravity of antifreeze and rust inhibitor mixture	Operator's manual
ELECTRICAL SYSTEM		
IMPORTANT: When the tractor is delivered, red cable is not connected to alternator terminal "B+". Further, the alternator three-terminal plug is not connected. Connect cable and plug before operating tractor for the first time.	Section 40, group 10
If the tractor is to be operated for a short time without battery (using a slave battery for starting), do not, under any circumstances, interrupt the circuit by switching off the starter switch before stopping the engine by means of fuel pump shut off cable. Further, it is recommended to use additional current (lights) whilst engine is running. Insulating tape on battery cable end leading to starting motor should not be removed.		
If this advice is disregarded, damage to alternator and regulator may result.		
If the batteries are to be installed in the tractor, remove insulating tape on terminal of battery cable. This is to be done if the tractor was shipped with dry-charged batteries or without batteries.
Connect batteries in the proper polarity (negative to ground). If they are improperly connected, the rectifier diodes will be immediately destroyed.	Section 40, group 10
First connect positive (+) cable and then ground (-) strap of each battery. Only then start tractor engine.	Section 40, group 10

BEFORE DELIVERING TRACTOR - Continued

Service	Specification	Reference
TIRES AND WHEELS		
Check tire inflation pressure	Operator's manual
Retighten wheel bolts	Section 80, group 15 and Operator's manual
LUBRICATION		
Check crankcase oil level	Top mark on dip stick	Operator's manual
Check transmission-hydraulic system oil level	Operator's manual
Lubricate all lubrication points on the tractor	Operator's manual
ENGINE		
Check air cleaner	Operator's manual
Fill fuel tank and start engine	Capacity: 62.5 liters (13.75 Imp.gals. = 16.5 U.S.gals.)	Operator's manual
Check lighting system, indicator lights and instruments for proper operation	Operator's manual
Check if speed control linkage moves easily	Section 20, group 40
Check engine idle speeds	Section 20, group 40
Check injection timing	Section 30, group 15
OPERATION		
Check clutch pedal adjustment	Approx. 25 mm (1 in.) clutch pedal free travel	Section 50, group 5
Check operation of Hi-Lo shift unit	Section 50, group 10
Shift transmission through all speeds	Operator's manual
Check differential lock operation	Operator's manual
Check PTO operation	Operator's manual
Check 3-point hitch operation	Operator's manual
Check hydraulic system operation	Section 70, group 5
Check brake system	Section 60, group 15

BEFORE DELIVERING TRACTOR - Continued

Service	Specifications	Reference
Check steering operation	Section 60, group 10
Check seat operation	Operator's manual
Check operation of remote hydraulic cylinder (if equipped)	Section 70, group 5
GENERAL		
Tighten accessible nuts and attaching screws	Section 10, group 20
Attach roll gard (if equipped)	Tighten cap screws cross-wise 1. Step = 7 mkp (50 ft.lbs.) 2. Step = 41.5 mkp (300 ft.lbs.)	Section 80, group 20
Clean tractor and touch up paint

DELIVERY INSPECTION

A thorough discussion of the operation and service of the tractor at the time of its delivery helps to assure complete customer satisfaction.

Proper delivery should be an important phase of the dealer's program.

It is a well-known fact that many complaints have arisen simply because the owner was not shown how to operate and service his new tractor properly. Therefore, enough time should be devoted, at the customer's convenience, to introducing him to his new tractor and explaining to him how to operate and service it.

Using the tractor operator's manual as a guide, be sure that the owner understands the following points properly.

1. Adjusting the seat
2. Operation of control levers and instruments
3. Starting and shutting off the engine
4. The importance of the tractor break-in period
5. Use of counterweights and proper inflation pressure as well as filling of tires with water and calcium chloride, if required
6. Operating the complete hydraulic system
7. Operating the power shaft and belt pulley (if equipped)
8. The importance of the safety rules
9. The importance of lubrication and periodic service

AFTER-SALES INSPECTION

In the interest of the purchaser and the dealer an after-sales inspection should be carried out by the dealer after the first 100 hours of using a new John Deere tractor.

The purpose of this inspection is to make sure that the customer is receiving satisfactory performance from his tractor. At the same time, the inspection should reveal whether or not the tractor is being operated, lubricated and serviced properly.

Through this inspection a needless volume of service work can be eliminated by preventing

minor difficulties from developing into serious problems later on. It also will promote stronger dealer-customer relations and give the customer an opportunity to ask questions that may have arisen during the first few days of use.

Thereby the dealer has the further opportunity of promoting the possible sale of other new equipment.

The following inspection program is recommended:

AFTER-SALES INSPECTION

Service	Specifications	Reference
COOLING SYSTEM		
Check coolant level	Coolant level should be midway between radiator core and bottom edge of filler neck	Operator's manual
Clean exterior of radiator
Check hose connections
FUEL SYSTEM		
Check fuel filter for water or sediment and clean transfer pump screen	Operator's manual
Check line connections
ELECTRICAL SYSTEM		
Check gravity of battery electrolyte	Gravity should be 1.260 at an electrolyte temperature of 27°C (80°F)	
Check electrolyte level of batteries	To bottom of filler neck in each cell	Operator's manual
Check tension of fan belt	19 mm (3/4 in.) deflection with a 9 kp (20 lbs.) force	Operator's manual and section 20, group 35
Start engine and check operation of lights, indicator lamps and instruments	Operator's manual
LUBRICATION		
Check crankcase oil level	Top mark on dip stick	Operator's manual
Check transmission oil level	Operator's manual
Check oil level of manual steering gear housing	Add oil up to filler hole	Operator's manual
Check oil level of belt pulley housing	Add oil up to filler hole	Operator's manual
Lubricate clutch throw-out bearing	Operator's manual
Lubricate 3-point hitch	Operator's manual

AFTER-SALES INSPECTION

Service	Specifications	Reference
ENGINE		
Check air cleaner	Operator's manual
Check valve clearance	Intake valve: 0.35 mm (0.014 in.) Exhaust valve: 0.45 mm (0.018 in.)	Section 20, group 10
Check engine speed under load as well as fast and slow idle speed	Section 20, group 40
Check engine performance	Section 10, group 20
GENERAL		
Check clutch pedal adjustment	Approx. 25 mm (1 in.) free travel	Section 50, group 5
Check operation of Hi-Lo shift unit	Section 50, group 10
Shift transmission through all speeds	Operator's manual
Check operation of PTO	Operator's manual
Check differential lock	Operator's manual
Check operation of hydraulic system	Section 70, group 5
Check steering system	Section 60, group 10
Check brakes	Section 60, group 15
Tighten accessible nuts and cap screws	Section 10, group 20
Tighten roll guard attaching screws and nuts	41.5 mkp (300 ft.lbs.)
Tighten accessible hydraulic lines
Visual inspection of tractor	Damaged paint, loose connections, proper positioning of hoses and lines, leaks, operation of all mechanical parts

Group 15
LUBRICATION AND PERIODIC
SERVICE

For brands of oil and lubricants to be used as well as for lubricating and servicing the tractor 1530, see operator's manual.



Group 20

ENGINE AND TRACTOR TUNE-UP

GENERAL INFORMATION

Before tuning up the engine, determine whether a tune-up will restore operating efficiency. If there is doubt, the following preliminary tests will help to determine if the engine can be tuned up.

PRELIMINARY ENGINE TESTING

Service	Specifications	Reference
Checking air intake system by means of vacuum gauge	355 to 635 mm (14 to 25 in.) water head; engine running at fast idle speed	 "Fundamentals of Service, Engine" manual under "Diagnosis and Testing"
Check radiator for air bubbles or oil film
Check compression (min. reading)	21 kp/cm ² (300 psi)	 "Fundamentals of Service, Engine" manual under "Diagnosis and Testing"
Measure engine horsepower at powershaft (using a dynamometer)	Record measured performance and compare with performance measured after carrying out "Engine Tune-up"

ENGINE TUNE-UP

Service	Specifications	Reference
AIR INTAKE SYSTEM		
Service air cleaner and check system for leaks	 Operator's manual and "Fundamentals of Service, Engine" manual
Check crankcase vent tube for foreign particles (restriction)
Tighten cylinder head cap screws	15 mkp (110 ft.lbs.)	Section 20, group 10
Check and adjust valve clearance	Intake valve: 0.35 mm (0.014 in.) Exhaust valve: 0.45 mm (0.018 in.)	Section 20, group 10
BATTERIES		
Thoroughly clean wires, connections and batteries
Tighten cable clamp screws
Liberally coat battery terminals and cable connectors with petroleum jelly
Check electrolyte level of battery	Operator's manual
Check specific gravity of electrolyte	Operator's manual
ALTERNATOR		
Check fan belt tension	19 mm (3/4 in.) deflection with 9 kp (20 lbs.) force	Section 20, group 35
FUEL SYSTEM		
Check fuel tank and lines for leaks or restriction
Clean screen of fuel transfer pump	Operator's manual
Check fuel filter element and replace, if necessary	Section 30, group 10
Check injection timing and adjust, if necessary	Section 30, group 15
Bleed fuel system	Section 30, group 15
Check engine speeds and adjust speed control linkage, if necessary	Section 20, group 40

ENGINE TUNE-UP - Continued

Service	Specifications	Reference
ENGINE LUBRICATION SYSTEM		
Check engine oil pressure	3.5 to 4.2 kp/cm ² (50 to 60 psi) at 2500 rpm	Section 20, group 30
COOLING SYSTEM		
Clean and flush cooling system	 "Fundamentals of Service, Engine" manual
Check radiator hoses for damage and leaks
Clear radiator core of restrictions

CHECKING ENGINE PERFORMANCE



After the engine has been tuned up as explained above, determine powershaft horsepower by means of a dynamometer, see "Fundamentals of Service, Engine" manual.

Compare measured performance in HP with output measured before carrying out "Engine tune-up".

TRACTOR TUNE-UP



After carrying out engine tune-up, make the following adjustments on the tractor:

Service	Specifications	Reference
ENGINE CLUTCH		
Adjust clutch pedal free travel	Approx. 25 mm (1 in.)	Section 50, group 5
FRONT WHEELS		
Clean and lubricate front wheel bearings	Section 80, group 15
Adjust front wheel bearings	Section 80, group 15
Check toe-in	3 to 6.5 mm (0.125 to 0.25 in.)	Section 60, group 5
Check torque of front wheel bolts	12 mkp (87 ft.lbs.)
HYDRAULIC BRAKES		
Bleed brake system	Section 60, group 15

TRACTOR TUNE-UP – Continued

Service	Specifications	Reference
HYDRAULIC SYSTEM		
Check stand-by pressure of hydraulic pump	156 to 160 kp/cm ² (2220 to 2280 psi)	Section 70, group 5
Check rockshaft lift cycle time at 2500 rpm engine speed	1.8 sec. to 2.3 sec.	Section 70, group 5
Check time required for extending or retracting remote cylinder at 2100 rpm engine speed	2 sec.	Section 70, group 5
Check operating pressure of Hi-Lo shift unit	8.8 to 9.5 kp/cm ² (125 to 135 psi)	Section 50, group 10
Check operating pressure of PTO clutch and PTO brake	8.8 to 9.5 kp/cm ² (125 to 135 psi)	Section 50, group 35
TIRES		
Check tire inflation pressure	Operator's manual
TORQUES		
Check all accessible cap screws and nuts of tractor for proper torque	Torque chart

STANDARD TORQUES

Recommended torques in mkp and ft.lbs. for UNC and UNF cap screws						
Head marking (identifying strength)	 or 6.8 (6. S)*		 or 10.9 (10 K)**		 or 12.9 (12 K)***	
	Thread-O.D. (in.)	mkp	ft.lbs.	mkp	ft.lbs.	mkp
1/4	1	7	1.5	10	2	14
5/16	2	14	3	20	4	30
3/8	3	21	5	35	7	50
7/16	5	35	8	55	11	80
1/2	8	55	12	85	18	130
9/16	10	75	18	130	26	185
5/8	15	105	23.5	170	34.5	250
3/4	25.5	185	41.5	300	58	420
7/8	22****	160****	61.5	445	92.5	670
1	34.5	250	92.5	670	138.5	1000

NOTE: A variation of \pm 10% is permissible for all torques indicated in this chart.

Torque figures indicated above and in the various sections of this manual are valid for non-greased or non-oiled threads and heads unless otherwise specified. Therefore, do not grease or oil bolts or cap screws unless otherwise specified in this manual.

- * Regular bolts and cap screws
- ** Tempered steel high strength bolts and cap screws
- *** Tempered steel extra high strength bolts and cap screws
- **** Bolts and screws 7/8 in. and larger are often formed hot rather than cold, which accounts for the lower torque.

Group 25

TRACTOR SEPARATION

SEPARATING BETWEEN ENGINE AND TRACTOR FRONT END

REMOVAL

For safety disconnect ground straps from batteries.

Remove front end weights (if equipped).

Remove radiator cap and fuel tank cap. Remove radiator side grille screens and hood. Install radiator and fuel tank caps. Remove tool box and side frames.

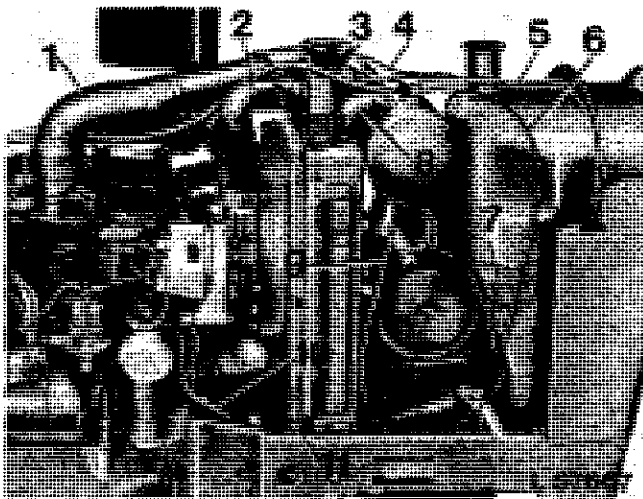

Fig. 1 — Separating between Tractor Front End and Engine

- | | |
|---------------------------|---|
| 1 Air intake pipe | 7 Cable of fuel gauge sending unit |
| 2 Upper water hose | 8 Hose elbow |
| 3 Leak-off and bleed line | 9 Cable of air cleaner restriction warning switch |
| 4 Fuel return line | 10 Fuel inlet line, tank to fuel transfer pump |
| 5 Support rod | 11 Oil cooler return line |
| 6 Leak-off and bleed line | |

Disconnect air intake pipe (see 1, fig. 1) at engine intake manifold and at air cleaner.

Disconnect leak-off and bleed lines 3 and 6 at hydraulic oil reservoir.

Remove support rod 5 at top of radiator. Disconnect fuel return line 4 at fuel tank.

Disconnect cable 9 on models having an air cleaner restriction warning switch and disconnect cable 7 at fuel gauge sending unit.

Drain coolant and disconnect upper and lower water hoses at radiator.

Only on tractors equipped with oil cooler: Remove hose elbow 8 between hydraulic oil reservoir and oil cooler at oil cooler end. Disconnect return oil line 11 at bottom of oil cooler.

Only on tractors without oil cooler: Disconnect return oil line at top and bottom hose and remove.

NOTE: Plug lines and openings immediately with plugs or caps to prevent loss of oil and entering of dirt into the system.

Remove screws securing fan shroud to radiator and slide over fan to the rear.

Remove screws securing radiator to front axle support and lift out radiator to the left of tractor.

Close fuel shut-off valve at bottom of fuel tank.

Disconnect fuel inlet line 10 at fuel tank and fuel transfer pump. Remove transfer pump and fuel inlet line.

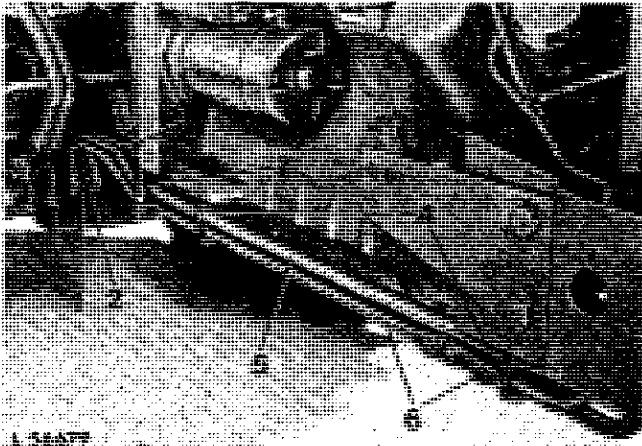

Fig. 2 — Disconnecting Hydraulic Lines

- 1 Retainer
- 2 Cap screw
- 3 Return line to transmission case
- 4 Clamps
- 5 Hydraulic pump inlet line
- 6 Hydraulic pump pressure line
- 7 Power steering pressure line

Remove both clamps (see 4, fig. 2).

Unscrew cap screw 2 and remove retainer 1 which supports the hydraulic pump inlet line 5 and return line 3 of oil cooler or oil reservoir (if not equipped with oil cooler).

On tractors not equipped with Hi-Lo transmission and independent PTO: Take care that the check valve installed in hydraulic pump inlet line 5 is not lost when the inlet line is removed.

Remove power steering pressure line 7 (if equipped).

Disconnect pressure line 6 at union.

Disconnect drag link at bell crank.

Remove clamping screw of hydraulic pump drive shaft.

Place a support stand under clutch housing.

Insert wooden blocks between front axle and front support to prevent the latter from tipping sideways.

Attach JDG-9 support stand to front support.

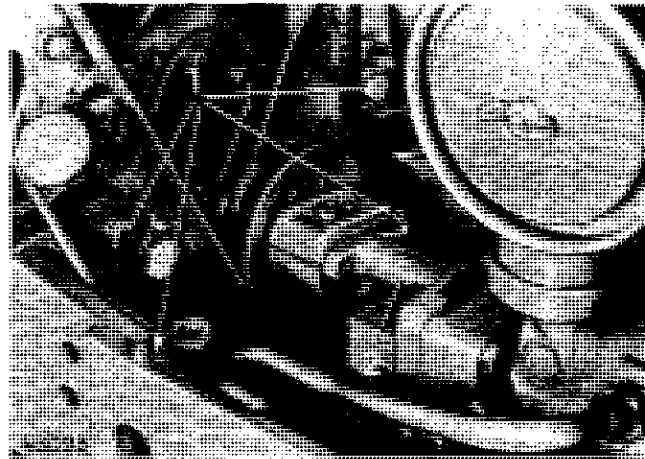

Fig. 3 — Attaching Points of Tractor Front End

- 1 Attaching screws of front axle support
- 2 Hydraulic pump drive shaft

Remove cap screws (see 1, fig. 3) of front support and both cap screws located at the rear of front support and separate front end from engine. Take measures to prevent front of tractor from tipping forwards (drain fuel tank if it contains too much fuel or support front end of tractor).

INSTALLATION

Make sure woodruff key is installed in shaft of hydraulic pump.

Move tractor front end toward engine.

Engage pump shaft in hydraulic pump drive shaft and at the same time slide oil return line and hydraulic pump inlet line into clutch housing bores (making sure both seal rings have been installed) and tighten both lines (see fig. 2). Tighten cap screw (see 2, fig. 2) of retainer 1 to the specified torque.

IMPORTANT: On tractors not equipped with Hi-Lo unit and independent PTO: Ensure check valve is inserted in hydraulic pump inlet line before it is installed.

Attach front end of tractor to engine. Tighten cap screws to specified torque. Tighten hydraulic pump drive shaft clamping screw to specified torque.

NOTE: Do not tighten clamping screw of hydraulic pump drive shaft until tractor front end is secured to engine.

Install fuel transfer pump and connect fuel lines.

Remove JDG-9 support stand.

Make sure transfer pump inlet line is behind and below fuel pressure line.

Open fuel tank shut-off valve.

Connect cable to fuel gauge sending unit and to air cleaner restriction warning switch (on some models).

Lift and slide radiator into location from the left side of tractor. Slide fan shroud forward over radiator and secure with screws. Secure radiator to front axle support. Install upper and lower water hoses.

Only on tractors equipped with oil cooler: Connect hose elbow between hydraulic oil reservoir and oil cooler at top of oil cooler and return line at bottom of oil cooler (see fig. 1).

Only on tractors not equipped with oil cooler: Connect oil line to oil reservoir and tighten both hose clamps.

Connect leak-off and bleed lines to hydraulic reservoir.

Connect hydraulic pump pressure line and install line spacers and clamps (see fig. 2).

Connect air intake pipe at manifold and air cleaner.

Attach drag link to bell crank and tighten slotted nut to specified torque.

Install hood and radiator side grille screens.

Fill radiator with clear, soft water, adding an anti-freeze and rust inhibitor mixture (see operator's manual).

Connect battery ground straps.

IMPORTANT: Always connect ground straps to negative(-) pole of batteries.

Start engine and check fuel lines, hydraulic lines and water hoses for leaks.

REMOVING AND INSTALLING ENGINE

NOTE: For most engine service operations the engine need not be removed. However, if the crankshaft has to be removed or in case of major overhaul, remove engine.

REMOVAL

For safety disconnect ground straps from batteries.

Separate tractor front end from engine, as explained previously.

Disconnect cables between alternator and regulator by removing three-terminal plug at alternator. Disconnect red cable at terminal B+ of alternator.

Disconnect all cables 4 at starting motor (see fig. 4). Disconnect oil pressure warning switch cable 3.

Disconnect flexible shaft 2 of speed-hour meter at clutch housing and camshaft. If necessary, replace gasket.

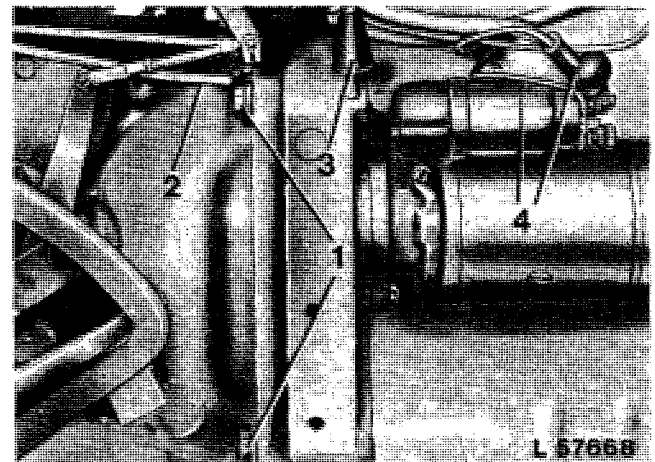

Fig. 4 — Separating between Engine and Clutch Housing, R.H. Side

- 1 Engine attaching screws
- 2 Flexible shaft of speed-hour meter
- 3 Oil pressure warning switch
- 4 Starter cables

On tractors equipped with starting fluid aid: Disconnect starting fluid line at intake manifold.

Remove bleed line of hydraulic oil reservoir from clamp at rocker arm cover.

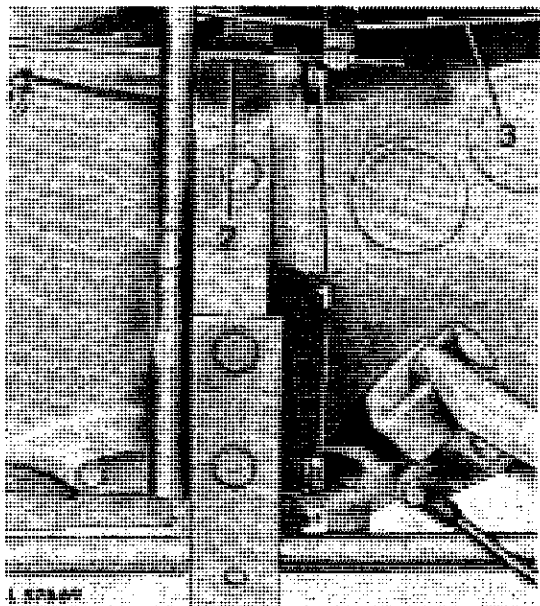

Fig. 5 — Separating between Engine and Clutch Housing, L. H. Side

- 1 Engine attaching screws
- 2 Speed control rod
- 3 Shut-off cable

Disconnect speed control rod 2 (fig. 5) and shut-off cable 3 at fuel injection pump.

On tractors with underneath muffler: Remove muffler.

Disconnect temperature gauge sensing bulb from cylinder head.

Remove left dash panel as well as both batteries.

Remove cap screws attaching cowl to flywheel housing.

Attach JD 244-1 and 244-2 engine lifting eyes to cylinder head and attach engine to a suitable hoist.

Remove cap screws 1 (figs. 4 and 5) attaching flywheel housing to clutch housing.

Remove engine by means of the hoist.

IMPORTANT: Move engine properly in line with drive shaft and hollow drive shaft until these shafts come free of the engine dual stage clutch disks, or free of clutch disk and torsion damper if tractor is equipped with a single stage clutch.

INSTALLATION

Align engine properly with drive shaft and hollow drive shaft. Move engine towards rear of tractor. Align splines of both shafts with splines of clutch disks (tractor with dual-stage clutch), or (if equipped with a single-stage clutch) with splines of clutch disk and torsion damper. Align screw holes of flywheel housing with holes in clutch housing. Slide engine evenly towards clutch housing. Engage two dowels of flywheel housing in bores of clutch housing until engine is in full contact with clutch housing.

IMPORTANT: Make sure flywheel housing is flush against clutch housing before tightening cap screws to specified torque.

Attach cowl to flywheel housing.

Connect speed control rod and shut-off cable to fuel injection pump.

Insert flexible tube of coolant temperature gauge in cylinder head and tighten retaining screw.

Connect three-terminal plug at alternator, and red cable to alternator terminal B+.

Connect cables to starting motor.

Connect cable to oil pressure warning switch.

Install both batteries.

IMPORTANT: Connect starter cable to positive poles of batteries.

Lubricate gasket of flexible speed-hour meter shaft and attach shaft to clutch housing (see 2, fig. 4). Make sure driving tab of flexible shaft engages in slot of camshaft. Do not tighten excessively to avoid damage to the gasket resulting in leakage.

On tractors equipped with starting fluid aid:
Connect starting fluid line to intake manifold.

On tractors equipped with underneath muffler:
Install muffler.

Secure oil reservoir leak-off and bleed line to rocker arm cover.

Attach tractor front end to engine.

IMPORTANT: Connect ground straps of batteries to negative(-) poles.

NOTE: If engine has been overhauled, tune up engine as explained in group 20.

REMOVAL AND INSTALLATION OF CLUTCH HOUSING

NOTE: Separating and joining the tractor between engine and clutch housing as well as between clutch housing and transmission case is explained below. Where the tractor is to be separated depends on the individual repair operation. If, e.g., repair work has to be carried out on the transmission, separation between the clutch housing and the transmission case will be sufficient.

REMOVAL

Disconnect battery ground straps.

Drain transmission oil.

Separate engine from clutch housing as explained under "REMOVING ENGINE"; the tractor front end may remain attached to the engine.

Disconnect drag link at steering arm.

Disconnect hydraulic oil reservoir leak-off and bleed line (see 5, fig. 6) at transmission shift cover.

Remove clamps (see 4, fig. 2), screw 2 and retainer 1 which secure suction line 5 of hydraulic pump and return line 3 of oil cooler or oil reservoir (if not equipped with oil cooler) to front side of clutch housing.

On tractors not equipped with Hi-Lo transmission and independent PTO: Take care not to lose check valve installed in hydraulic pump inlet line when latter is removed.

On tractors equipped with power steering:
Disconnect power steering pressure line at unions.

Remove clamp (see 6, fig. 6) and hydraulic pump pressure line 3.

Insert wooden blocks between front axle and front support to prevent front support from tipping sideways.

Attach JDG-9 support stand to tractor front end. Similarly the rear of tractor should be suspended to a suitable hoist or be supported under the transmission case by means of support stand.

Roll engine and tractor front end away from clutch housing.

IMPORTANT: Move engine properly in line with drive shaft and hollow drive shaft until these shafts come free of the clutch disks of the engine dual-stage clutch, or on tractors with single-stage clutch, free of clutch disk and torsion damper.

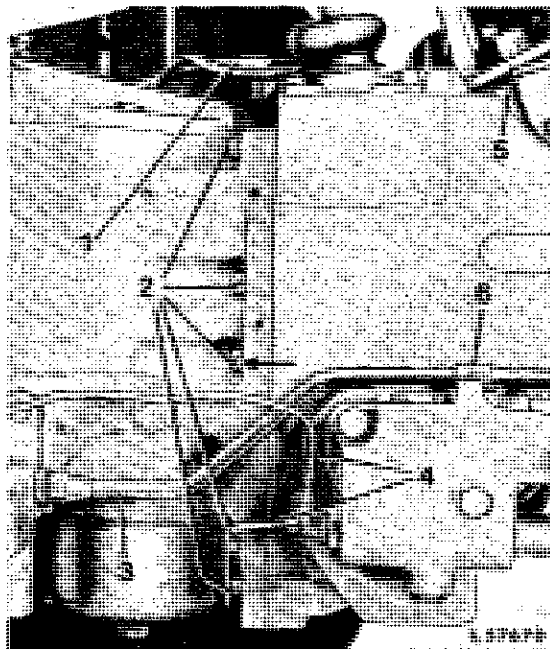

Fig. 6 — Separating between Clutch Housing and Transmission Case, R. H. Side

- | | |
|--------------------------------|---|
| 1 Rear wiring harness | 5 Hydraulic oil reservoir leak-off and bleed line |
| 2 Attaching screws | 6 Pipe clamp |
| 3 Hydraulic pump pressure line | |
| 4 Brake lines | |

Disconnect brake lines (see 4, fig. 6) at brake valve.

Remove transmission shield.

Disconnect rear harness at connector. Disconnect cable at start safety switch.

On tractors equipped with Hi-Lo shift unit: Remove cap screws (see 3, fig. 7). Disconnect connecting rod from shaft arm and remove cover 4 complete with shaft.

On tractors equipped with independent PTO: Before removing cover (see 4, fig. 7), move PTO control lever in engaged position. After cover 4 has been removed, do not move PTO control lever otherwise lock balls and springs will drop out of cover.

Remove screws attaching transmission shift cover to clutch housing. Remove transmission shift cover complete with gear shift levers.

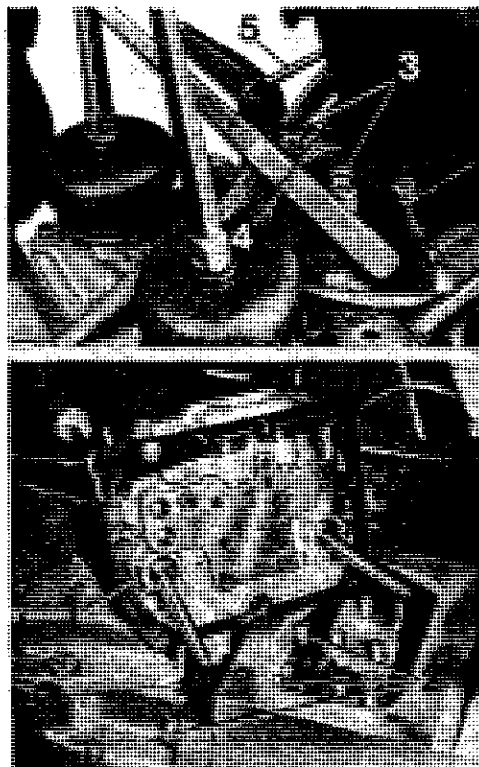

Fig. 7 — Removing Shift Cover

- | | |
|-----------------------------------|------------------|
| 1 Shift cover | 3 Cap screws |
| 2 Clutch housing attaching screws | 4 Cover |
| | 5 Connecting rod |

Remove transmission oil filter.

Remove cap screws 2 (figs. 6 and 7) securing clutch housing to transmission case, and separate clutch housing from transmission case.

Discard seal rings provided between the two housings.

INSTALLATION

Install new seal rings in clutch housing front facing transmission case.

Slide clutch housing against transmission case.

Slide PTO drive shaft into needle bearing of clutch housing quill. Mesh PTO gear with hollow PTO drive shaft gear.

Make sure clutch housing is flush against transmission case before tightening cap screws to the specified torque.

NOTE: Before installing the third (from top) retaining screw at right-hand side of clutch housing (see arrow, fig. 6), coat screw with oil-resistant sealant.

NOTE: If clutch housing has also been separated from engine, assemble as explained under "Installation of Engine".

Insert hydraulic pump inlet line (see 5; fig. 2) and oil cooler or oil reservoir return line 3 in bore of clutch housing and secure by means of screw and retainer. Tighten screw to the specified torque.

On tractors not equipped with HIGH-LOW unit and independent PTO: Make sure check valve is inserted in hydraulic pump inlet line before line is installed.

Install hydraulic pump pressure line.

On tractors equipped with power steering: Connect power steering pressure line.

As regards further installation operations reverse removal procedure.

IMPORTANT: Connect ground straps of batteries to negative(-) poles.

REMOVAL AND INSTALLATION OF FINAL DRIVES

REMOVAL

NOTE: The removal of both final drives is explained below. If only one final drive is to be removed, do necessary work only.

For safety disconnect ground straps at batteries.

Lift up rear of tractor by means of a suitable jack or hoist and remove rear wheels.

⚠ CAUTION: Support transmission safely to prevent tipping of tractor.

Disconnect rear wiring harness at connector.

Remove rear fender and roll-over guard.

Disconnect brake lines on both final drive housings.

On tractors equipped with selective control valve(s): Disconnect hydraulic lines and remove both screws securing bracket to the right-hand final drive housing.

Cover connections and exposed openings with plastic plugs or caps to prevent particles of dirt from entering the system.

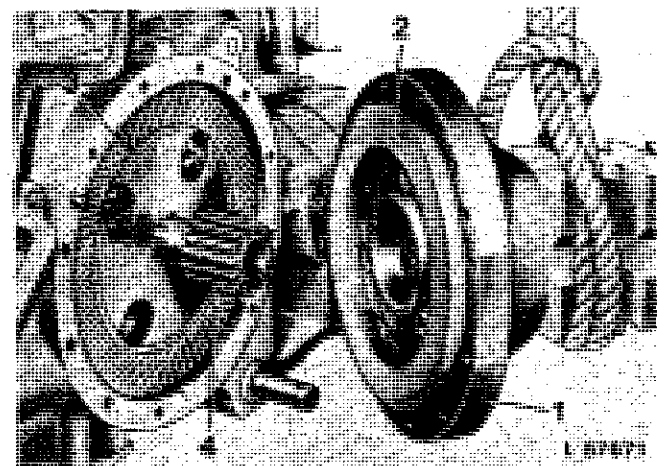

Fig. 8 — Removing Final Drive

- 1 Final drive housing
- 2 Pressure ring
- 3 Brake disk
- 4 Final drive shaft

Remove selective control valve(s).

Attach final drive to hoist. Remove final drive attaching screws. Separate final drive housing from transmission case. Withdraw housing evenly until final drive shaft gear is no longer in mesh with planetary gears of final drive.

INSTALLATION

NOTE: If the brake disk was removed, install it with the brass-interwoven upper facing toward brake surface of transmission case.

Position new gasket between final drive housing and transmission case.

Attach final drive to transmission case by means of a suitable hoist. Make sure final drive shaft gear engages with planetary gears and that the dowels are guided into their respective bores.

Tighten final drive attaching screws to the specified torque.

On tractors with selective control valve(s): Attach control valves with bracket to right-hand final drive housing. Connect hydraulic lines.

Connect brake lines and bleed brakes, as explained in section 60, group 15.

Install rear fenders and roll-over guard. Tighten cap screws to specified torque.

Connect rear wiring harness at connector.

Install rear wheels and tighten to the specified torque.

IMPORTANT: Connect ground straps to negative(-) poles of batteries.

REMOVAL AND INSTALLATION OF ROCKSHAFT

REMOVAL

IMPORTANT: Work on the hydraulic system requires extreme care and cleanliness. Minute dirt or foreign particles, scratches, nicks or burrs may put the hydraulic system out of function. Before removing the rockshaft, check hydraulic system for leaks.

For safety, disconnect ground straps from batteries.

Remove transmission shield. Disconnect cable 1 (fig. 9) from start safety switch.

Remove operator's seat. Disconnect both lift links at lift arms.

Disconnect oil return line (see 2, fig. 9) of selective control valves (if equipped) at union on rockshaft.

Remove pressure lines 3 (tractors equipped with selective control valve).

Free rear wiring harness 4.

Disconnect socket cable 5 at connector.

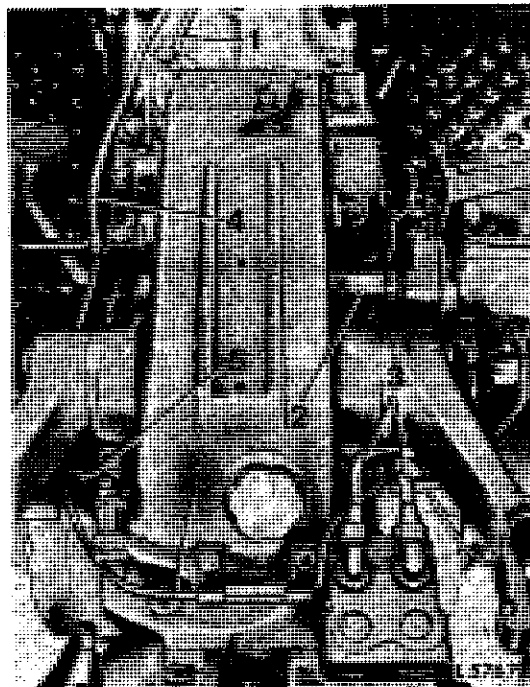

Fig. 9 — Rockshaft, Installed

- | | |
|--|----------------------------------|
| 1 Cable of start safety switch | 4 Rear wiring harness |
| 2 Oil return line | 5 Cable to socket (for handlamp) |
| 3 Pressure lines to coupler (tractor with selective control valve) | |

Move selector lever in position "L" (load control) so that the control linkage roller slides along the cam of the control arm when removing the rockshaft.

Attach engine lifting eye No. JD 244-2 to top of rockshaft housing.

Remove rockshaft attaching screws. Lift rockshaft assembly off transmission case by means of a hoist.

Take care not to damage rear harness.

NOTE: After removing rockshaft, cover transmission case to prevent foreign particles from falling into the transmission.

INSTALLATION

Use a new gasket between transmission case and rockshaft. Make sure dowels in transmission case and seal ring of oil inlet passage are installed.

Move selector lever in position "L" so that the control linkage with roller can be slid over the cam.

Lift rockshaft on transmission case, using a suitable hoist.

If equipped: Connect oil return line 2 (fig. 9) of selective control valve to rockshaft housing. Install pressure lines 3.

Tighten rockshaft attaching screws to the specified torque.

Connect cable of start safety switch and hand lamp socket.

Secure rear wiring harness 4 to rockshaft. Install transmission shield on transmission case.

Attach lift links to lift arms. Install operator's seat.

For adjustment of rockshaft see section 70, group 20.

IMPORTANT: Connect ground straps to negative(-) poles of batteries.

TORQUES FOR HARDWARE

Front support to engine, cap screws		
front cap screws (4 used)	23.5 mkp	170 ft.lbs.
rear cap screws (2 used)	18.0 mkp	130 ft.lbs.
Hydraulic pump drive shaft, clamping screw	4.4 mkp	32 ft.lbs.
Drag link to bell crank or steering arm, slotted nut	7.7 mkp	55 ft.lbs.
Clutch housing to engine, cap screws	23.5 mkp	170 ft.lbs.
Clutch housing to transmission, cap screws	11.7 mkp	85 ft.lbs.
Retainer of hydraulic lines to clutch housing, cap screw	4.5 mkp	32 ft.lbs.
Final drive housings to transmission case, cap screws	11.7 mkp	85 ft.lbs.
Roll-over guard cap screws (tighten crosswise)		
1. Step	7.0 mkp	50 ft.lbs.
2. Step	41.5 mkp	300 ft.lbs.
Rockshaft housing to transmission case, cap screws	11.7 mkp	85 ft.lbs.
Rear wheels to rear axle, wheel bolts	18 mkp	130 ft.lbs.
Wheel disk to hub (on tractors equipped with rack-and-pinion axle)	41.5 mkp	300 ft.lbs.

** NOTE: If cotter pin cannot be inserted when tightening to the specified torque, turn nut to next slot and secure with cotter pin.*

SPECIAL TOOLS

No.	Description	Use
JDG-1*.....	Engine sling	Engine removal
JD 244-1*	Lifting eye, straight	Removing and installing assemblies
JD 244-2*	Lifting eye, bent	ditto
JDG-9*	Support stand	Separating tractor

* SERVICE TOOLS INC., 1901 INDIANA AVENUE, CHICAGO, ILLINOIS 60616, USA

Section 20 ENGINE

CONTENTS OF THIS SECTION

GROUP 5 — GENERAL INFORMATION, DIAGNOSING MALFUNCTIONS	
	Page
General information	5-2
Diagnosing malfunctions	5-2
 GROUP 10 — CYLINDER HEAD AND CAM-SHAFT	
General information	10-1
Diagnosing malfunctions	10-1
Cylinder head	10-1
Removal	10-1
Repair	10-2
Installation	10-4
Adjusting valve clearance	10-4
Camshaft	10-5
Removal	10-5
Repair	10-5
Installation	10-5
Specifications	10-6
Torques for hardware	10-8
Special tools	10-8
 GROUP 15 — CYLINDER BLOCK, LINERS, PISTONS AND CONNECTING RODS	
General information	15-1
Removal	15-1
Repair	15-1
Assembly	15-4
Installation	15-4
Specifications	15-7
Torques for hardware	15-9
Engine break-in	15-9
Tune-up data	15-10
Special tools	15-10
 GROUP 20 — CRANKSHAFT, MAIN BEARINGS AND FLYWHEEL	
General information	20-1
Removal	20-1
Repair	20-1
Installation	20-4
Specifications	20-6
Torques for hardware	20-7
Special tools	20-7

GROUP 25 — TIMING GEAR TRAIN	
General information	25-1
Removal	25-1
Repair	25-2
Installation	25-3
Specifications	25-5
Torques for hardware	25-6
Special tools	25-6
 GROUP 30 — OIL PUMP, OIL PRESSURE REGULATING VALVE AND OIL FILTER	
General information	30-1
Removal	30-2
Repair	30-3
Installation	30-4
Adjusting engine oil pressure	30-5
Specifications	30-5
Torques for hardware	30-6
Special tools	30-6
 GROUP 35 — COOLING SYSTEM	
General information	35-1
Diagnosing malfunctions	35-2
Repair	35-2
Radiator	35-2
Adjusting fan belt	35-2
Water pump	35-2
Checking thermostat	35-4
Specifications	35-5
Torques for hardware	35-5
Special tools	35-5
 GROUP 40 — SPEED CONTROL LINKAGE	
General information	40-1
Removal and disassembly	40-1
Repair	40-3
Assembly and installation	40-3
Adjusting speed control Linkage	40-4
Specifications	40-5

Group 5

GENERAL INFORMATION, DIAGNOSING MALFUNCTIONS

GENERAL INFORMATION

The tractor is equipped with a 3-cylinder vertical in-line, valve-in-head, 4-cycle diesel engine with direct fuel injection. The "wet" cylinder liners can be replaced one at a time. The pistons are of forged aluminium alloy and cam-ground. Each piston has two single, cast-iron compression rings and one oil control ring. All ring grooves are above the piston pin. The case-hardened piston pins are full floating and are held in place by two snap rings each.

The crankshaft is a one-piece, heat-treated, steel forging. It is supported in four replaceable two-piece main bearings machined to close tolerances.

The connecting rods are provided with a bronze bushing and a two-piece, replaceable bearing cap each.

A camshaft supported in the cylinder block controls the valves and drives the fuel transfer pump.

The intake and exhaust valves are supported in the cylinder head. The valve stems slide in bores in the cylinder head. The rocker arm shaft assembly is fitted on top of the cylinder head.

The engine is supplied with lubricating oil by a gear pump. The lubricating oil passes through a full-flow oil filter in the main oil circuit. To ensure engine lubrication, the oil filter is provided with a by-pass valve which opens when the filter element is restricted.

The engine has a pressure cooling system consisting of the radiator, water pump, multi-blade fan and thermostat.

DIAGNOSING MALFUNCTIONS

ENGINE WILL NOT CRANK

Dead batteries

Bad battery connections

Defective main switch or start safety switch

Starter solenoid defective

Starter defective

Water, dirt or air in fuel system

Fuel filter clogged

Stuck shut-off knob

Dirty or faulty fuel injectors

Defective injection pump

Defective fuel transfer pump

Shut-off valve at fuel tank closed

Injection pump out of time

ENGINE HARD TO START OR WILL NOT START

Loose or corroded battery connections
Low battery output

Excessive resistance in starter circuit

Too high viscosity crankcase oil

ENGINE RUNS IRREGULARLY OR STALLS FREQUENTLY

Coolant temperature too low

Insufficient fuel supply



Suggest:

If the above button click is invalid.

Please download this document

first, and then click the above link

to download the complete manual.

Thank you so much for reading

Injector tips defective or leaking
Fuel filter or fuel lines clogged
Defective fuel transfer pump
Incorrect engine timing
Improper valve clearance
Cylinder head gasket leaking
Worn or broken compression rings
Valves stuck or burnt
Excessive back pressure
Engine compression too low
Engine overheated
Defective fuel injection pump

ENGINE MISSES

Water in fuel
Mixture of gasoline and diesel fuel
Air in fuel system
Defective fuel injectors
Defective fuel injection pump
Fuel injectors improperly installed
Leaking fuel injector seals
Engine overheated
Cams of camshaft worn
Worn valve springs
Worn or defective fuel transfer pump
Engine backfiring
Incorrect engine timing
Engine compression too low
Improper valve clearance
Burnt, damaged or stuck valves

LACK OF ENGINE POWER

Air cleaner clogged or dirty
Excessive resistance in air intake system
Fuel filter clogged
Defective fuel transfer pump
Defective fuel injection pump
Defective fuel injectors
Improper crankcase oil
Engine overheated
Engine clutch drags
Defective cylinder head gasket
Lobes of camshaft worn
Improper valve clearance
Improper valve timing
Burnt, damaged or stuck valves
Worn valve springs
Incorrect engine timing
Piston rings and cylinder liners excessively worn
Engine compression too low
Improper coolant temperature

ENGINE OVERHEATS

Lack of coolant in cooling system
Radiator core and/or side grille screens dirty
Loose or defective fan belt
Defective thermostat
Cooling system limed up
Engine overloaded
Injection pump delivers too much fuel
Damaged cylinder head gasket

<https://www.ebooklibonline.com>

Hello dear friend!

Thank you very much for reading.

Enter the link into your browser.

The full manual is available for immediate download.

<https://www.ebooklibonline.com>