

John Deere 1500 Powr-Till Seeder



JOHN DEERE

TECHNICAL MANUAL
John Deere 1500
Powr-Till Seeder

TM1152 (01MAR77) English

TM1152 (01MAR77)

LITHO IN U.S.A. (REVISED)
ENGLISH



1500 POWR-TILL SEEDER

Technical Manual

TM-1152 (Mar-77)

CONTENTS

	Page		Page
INTRODUCTION	2	CUTTER WHEEL UNITS	21
SAFETY AND YOU	3	General Information	21
GENERAL INFORMATION	4	Removing Line Shaft Assemblies	21
Description	4	Replacing Front Bearing	23
Lubrication	5	Replacing Front Sprocket	23
DIAGNOSING MALFUNCTIONS AND TESTING ..	6	Replacing Rear Shaft Components	24
Organizing the Diagnosis	6	Assembly	24
Diagnosing	6	END WHEEL DRIVE	25
POWERSHAFT	8	General Information	25
General Information	8	Axle and Axle Plate Disassembly	25
Removal and Installation	8	Installation	28
Disassembly	8	GRAIN MODEL DRIVES	28
Inspection and Repair	10	Drive Shaft Replacement	28
Assembly	11	Inner Bearing Replacement	30
GEAR CASE AND SLIP CLUTCH	11	Outer Bearing Replacement	30
General Information	11	Feed Shaft Bearing Replacement	31
Gear Case	11	Removing Grain Shifter	32
Removal	11	Grain Cups	32
Disassembly	13	GRASS BOX DRIVES	34
Inspection and Repair	15	Inner Bearing Replacement	34
Assembly	16	Drive Shaft Replacement	35
Installation	18	Outer Bearing Replacement	35
Slip Clutch	19	Grass Cups	36
Removal	19	SPECIFICATIONS	38
Disassembly	19		
Inspection	19		
Assembly	20		

All information, illustrations and specifications contained in this technical manual are based on the latest information available at the time of publication. The right is reserved to make changes at any time without notice.

Copyright © 1977
DEERE & COMPANY
Moline, Illinois
All rights reserved

INTRODUCTION



Use FOS Manuals for Reference

This technical manual is part of a twin concept of service:

- **FOS Manuals—for reference**
- **Technical Manuals—for actual service**

The two kinds of manuals work as a team to give you both the general background and technical details of shop service.

Fundamentals of Service (FOS) Manuals cover basic theory of operation, *fundamentals* of trouble shooting, *general* maintenance, and *basic* types of failures and their causes. FOS Manuals are for training new mechanics and for reference by experienced mechanics.

Technical Manuals are concise service guides for a specific machine. Technical Manuals are on-the-job guides containing only the vital information needed by an experienced mechanic.

When a service person should refer to a FOS Manual for more information, a FOS note is used in the TM to identify the reference.

Litho in U.S.A.



Use Technical Manuals for Actual Service

Some features of this technical manual.

- *Table of contents at front of manual*
- *Exploded views showing parts relationship*
- *Photos showing service techniques*
- *Specifications grouped for easy reference*

This technical manual was planned and written for you—an experienced mechanic. Keep it in a permanent binder in the shop where it is handy. Refer to it whenever in doubt about correct service procedures or specifications.

 This safety alert symbol identifies important safety messages in this manual. When you see this symbol, be alert to the possibility of personal injury and carefully read the message that follows.

“Right-hand” and “left-hand” sides are determined by facing the direction the seeder will travel when in use.

Because John Deere sells its products worldwide, U.S. units of measure are shown with their respective Metric equivalents throughout this operator's manual. These equivalents are the SI (International System) Units of Measure.

<https://www.ebooklibonline.com>

Hello dear friend!

Thank you very much for reading.

Enter the link into your browser.

The full manual is available for immediate download.

<https://www.ebooklibonline.com>

SAFETY AND YOU



T27999N

INTRODUCTION

 This safety alert symbol identifies important safety messages in this manual and on the drill. When you see this symbol, be alert to the possibility of personal injury and carefully read the message that follows.

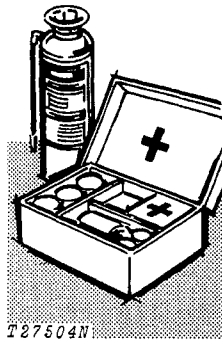

T27504N

Be prepared if an accident or fire should occur. Know where the first-aid kit and the fire extinguishers are located—know how to use them.

PERSONAL SAFETY

Avoid working on equipment with the tractor engine running. If it is necessary to make checks with the engine running, **ALWAYS USE TWO PEOPLE**—one, the operator, at the controls, the other person checking so as to be visible to the operator on the tractor seat. **KEEP HANDS AWAY FROM MOVING PARTS.**



H23440N

Always avoid loose clothing or any accessory—flopping cuffs, dangling neckties and scarves—that can catch in moving parts and put you out of work.

Always wear your safety glasses while on the job.

FLUIDS UNDER PRESSURE

Escaping fluid under pressure can have sufficient force to penetrate the skin, causing serious personal injury. Before disconnecting lines, be sure to relieve all pressure. Before applying pressure to the system, be sure all connections are tight and lines, pipes and hoses are not damaged.

Fluid escaping from a very small hole can be almost invisible. Use a piece of cardboard or wood, rather than hands, to search for suspected leaks.

If injured by escaping fluid, see a doctor at once. Serious infection or reaction can develop if proper medical treatment is not administered immediately.

GENERAL INFORMATION DESCRIPTION

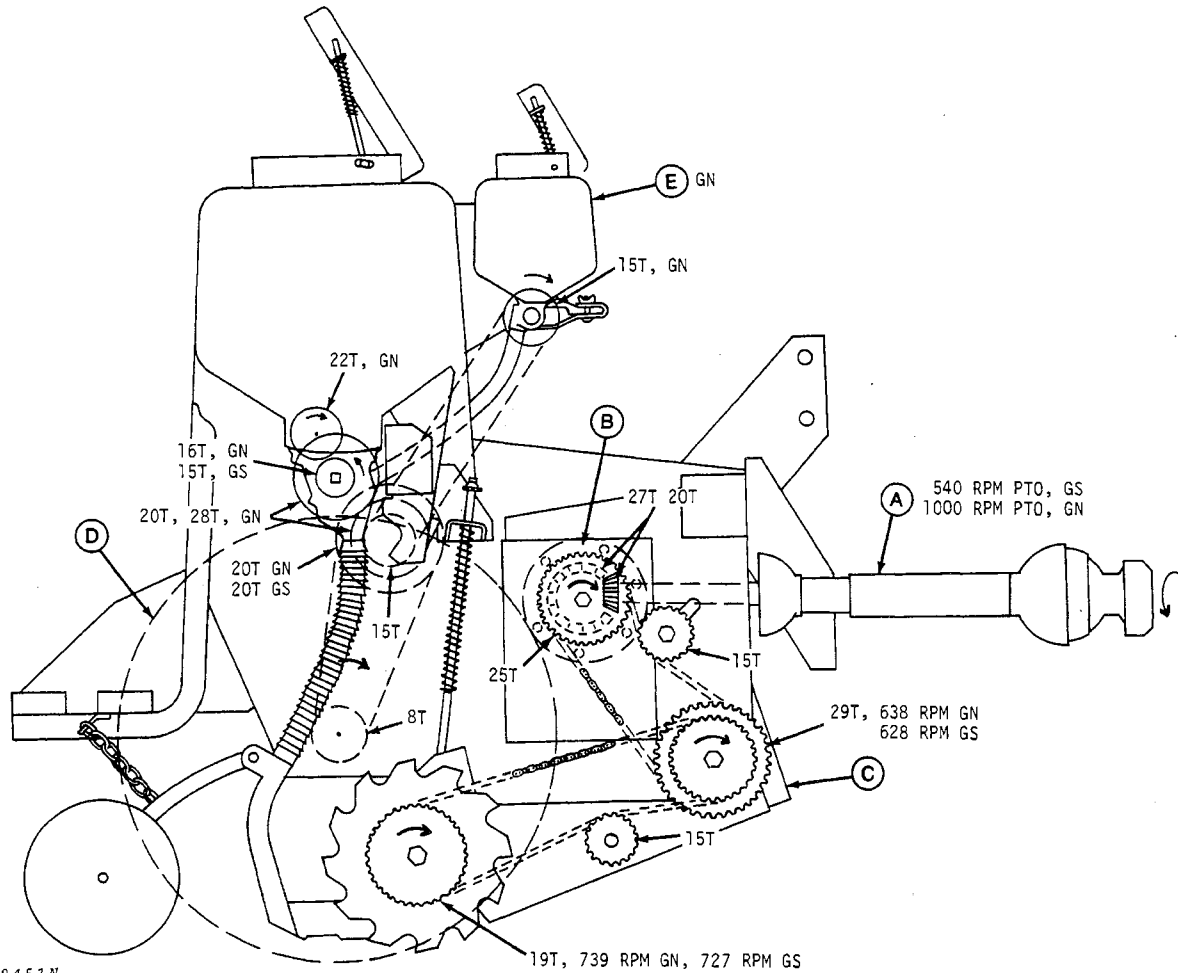

- | | | | | |
|-------------------|---------------------|----------------------------|--------------------|---------------------|
| A—Powr-Gard Drive | C—Cutter Wheel Unit | E—Grass Seed Box | PTO—Power Take-Off | GN—Grain Model Only |
| B—Slip Clutch | D—End Wheel | RPM—Revolutions Per Minute | T—Teeth | GS—Grass Model Only |

Power Train Diagram - 1500 Powr-Till Seeder

There are two models of the 1500 Powr-Till Seeder; a grass model and a grain model. The grass model has a 2-1/2 bushel (88 l) seed box and must be powered by a 540 rpm PTO. The grain model holds 10 bushels (352 l) and must be powered by a 1000 rpm PTO. A grass seed attachment (E) may be added to the grain model to make a combination grain and grass seeder (as illustrated).

The PTO drive is a Powr-Gard drive shaft (A), which fully protects the drive line from the tractor to the implement gear case. Power is transmitted from the gear case by a double roller chain to two hex. line shafts, which are joined. A double-disk slip clutch (B) is located on the gear case output shaft to protect the gear case and the units. Each cutter wheel unit (C) is driven by a fully enclosed lubricated roller chain.

The seed metering system is ground driven by the right-hand end wheel (D), and uses accurate and dependable fluted force feeds.

The power-driven cutter wheels till an area 1/2 to 3/4-inch (13-19 mm) wide. The cutter wheels are mounted in units of two wheels each. Each unit pivots about the two-piece line shaft and floats vertically. An adjustable down pressure spring is mounted on each unit.

The seeding rate is controlled by a single lever on both the grain and grass models. Seeds drop through rubber tubes into the seed furrow. Furrow depth is adjustable for varying moisture conditions and/or seed requirements, usually 3/4 to 1-inch (19 to 25 mm) deep.

LUBRICATION

System	Capacity	Type of Lubricant
Hex Shaft Drive Chain		John Deere Torq-Gard Supreme or an equivalent SAE 40 oil
Powershaft (center fitting)		John Deere Multi-Purpose Lubricant or an equivalent multi-purpose-type grease
Powershaft U-joints		John Deere Multi-Purpose Lubricant or an equivalent multi-purpose-type grease
Packer Wheel Axles		John Deere Multi-Purpose Lubricant or an equivalent multi-purpose-type grease
Roller Chains (end wheel drive and grass seed drive)		John Deere Torq-Gard Supreme or an equivalent SAE 40 oil
Roller Chain (cutter wheel housing)		John Deere Multi-Purpose Lubricant or an equivalent multi-purpose-type grease
Gear Case	2 qts (1.9 l)	John Deere SAE 90 Gear Lubricant or an equivalent SCL multi-purpose-type gear oil.
Wheel Bearings		John Deere Wheel Bearing Grease or an equivalent SAE multi-purpose-type grease

DIAGNOSING MALFUNCTIONS AND TESTING

ORGANIZING THE DIAGNOSIS

1. Know the Unit

Study this manual to know how the individual components work and their function in the over-all system.

Keep up with the latest service information. Read it and store it in a handy reference file.

2. Consult the Operator

Ask the operator how the unit was performing when the problem occurred. Find out if any corrective measures were already taken. Ask if the unit was serviced regularly as prescribed in the operator's manual.

3. Operate the Unit

If the unit can be safely operated, see for yourself how it malfunctions—don't rely completely on the operator's diagnosis.

4. Inspect the Unit

Visually check the unit. Look at the components for any cracked welds, loose hardware, damaged linkages, worn or broken lines, or anything that looks out of the ordinary.

5. List the Probable Causes

Write down the information you have learned by steps 1 through 4. What are the signs you found while inspecting the unit and what are the most probable causes as outlined under "Diagnosing"?

6. Reach Some Conclusions

Look over the possible causes and decide which ones are most likely. Reach your decision on the most probable cause and plan to check it first.

7. Test Your Conclusions

Before disassembling any components, test your conclusions to see which are correct. Tests narrow the possibilities and soon the actual cause will be pinpointed.

DIAGNOSING

Power train damage

Incorrect PTO speed - page 4
Slip clutch set too tightly - page 20

Slip clutch overheating

Incorrectly adjusted - page 20

Slip clutch does not slip

Incorrectly adjusted - page 20

Powershaft damage

Poor lubrication - page 5
Improper tractor hookup - See Operator's Manual

Powershaft disengages from tractor

Tractor PTO shaft too long - See Operator's Manual

Machine vibrates

Powershaft not properly aligned - page 11

Twisted powershaft

Overload on Powershaft

Powershaft not telescoping properly

Worn bearings - page 10
Spinner shields rusted - page 10
Poor lubrication - page 5
Shaft packed with dirt

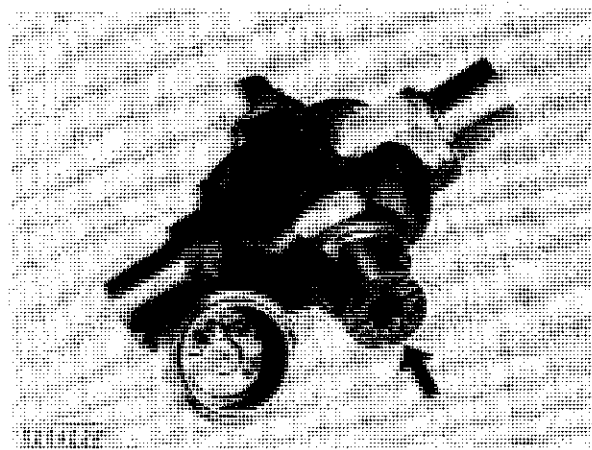

Galling or brinelling of U-Joint journal

Drive shaft rpm too high - page 4
Incorrect powershaft phasing - page 11

Journal cross end and cup chipping

Improper tractor hookup - See Operator's Manual

Abrasive corrosion on PTO shaft

Extreme low angle operation - See Operator's Manual

Noisy gears in gear case

Low on lubricant - page 5
Backlash incorrect - page 18
Rolling torque incorrect - page 17

Cutter wheels coming loose

Hex. axle installed backwards - page 24

Excessive Vibration of Units

Sprockets mismatched - page 25, "Important"

Cutter wheels not turning

Hex shaft drive chain broken - page 12
Individual unit chain broken - page 23
Shaft or gear broken in gear case - page 16
Clutch drive splines worn - page 19
Slip clutch too loose - page 19

Acrometer tallying incorrectly

Improper tire inflation or size.
Inflate tires to 28 psi (2 bar or kg/cm²).
Acrometer out of adjustment.
Adjust correctly, see Operator's Manual.
Land is not assumed size.
Remeasure land.
Tire slippage because of excessive down pressure.
Reduce pressure.
Excessive overlapping or double planting.
Be aware of driving patterns (for various field conditions) that would make the acrometer read higher.

Fluted-Feed shifter lever difficult to shift

Feed gate position too high.
Lower feed gate, position shifter lever in place; then place feed gate in desired position.

Fluted-Feed shifter does not stay in position

Bent or damaged shifter lever.
Replace entire assembly, page 32.

Varying quantities by individual feeds

Feed gates not all set the same.
Set all gates identically.
Feed cup out of adjustment with the fluted-feed roll.
Set the shifter on zero and move any cups that are not completely closed.

Quantities planted not agreeing with feed chart

Feed gates adjusted improperly.
Adjust gates, see Operator's Manual.
Heavier or lighter-than-average weight seed.
Check quantity drilled, see Operator's Manual.
Improper tire inflation.
Inflate tires to 28 psi (2 bar or kg/cm²).
Excessive overlapping or double planting.
Be aware of driving patterns (for various field conditions) that would make the feed chart appear incorrect.
Tire slippage because of excessive down pressure.
Use less pressure, or add weight to seeder.

Seed distribution stops

Broken shear pin in axle assembly.
Replace pin and check torque, page 25.
Broken chain.
Replace and check drive shaft for ease of rotation.
Feed shaft or hub rounded or worn.
Replace parts, page 31.

POWERSHAFT

GENERAL INFORMATION

The powershaft is made up of a front and rear section that slip-fit together. The front section couples to the PTO shaft of the tractor and the rear section is connected to the input shaft of the seeder gear case.

The powershaft is fully shielded at the front and partially shielded at the rear.

REMOVAL AND INSTALLATION

Push the button and pull straight back to separate the powershaft from the tractor.

To connect the powershaft to the tractor, do the following: 1) Liberally grease the seeder end of the powershaft before sliding the tractor end on; 2) Move the collar back on the hub against the stop; 3) Push the button and turn the collar until button is flush, locking collar to hub; 4) Align the splines by turning the collar and start assembly onto PTO shaft; 5) Push bell assembly forward firmly until coupler snaps into locked position.

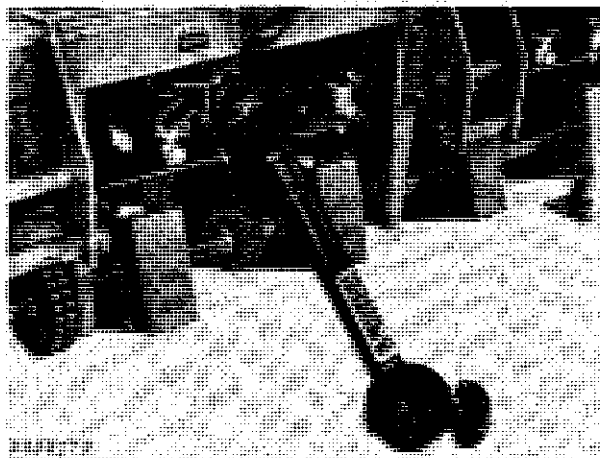

Fig. 1-Removing Powershaft

To remove the rear section, remove the single bolt connecting the powershaft yoke to the grooved input shaft; then pull the powershaft straight off.

DISASSEMBLY

IMPORTANT: If the powershaft does not telescope properly, damage will occur to the seeder. Disassemble, clean, and replace parts to insure proper telescoping action.

1. Remove the powershaft from the seeder (see Fig. 1).

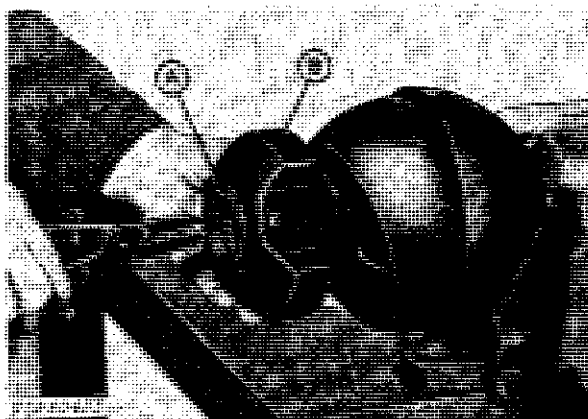

A—Snap Ring

B—Push-Collar Assembly

Fig. 2-Removing Snap Ring

2. Remove the snap ring (A, Fig. 2) after first placing the front section in a vise.

3. Remove the push-collar assembly (B).

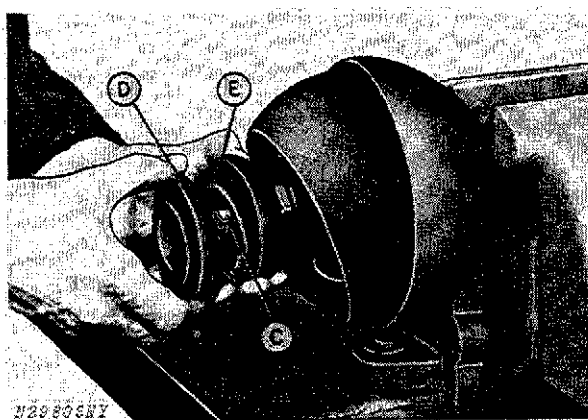

C—Steel Ball

D—Collar Retainer

E—Spring

Fig. 3-Removing Collar Retainer

4. Remove the three steel balls (C, Fig. 3) from the push button yoke; then remove the collar retainer (D) and spring (E).

10. Remove the nylon bearing from the rear section by spreading the ends apart and lifting off (Fig. 8).

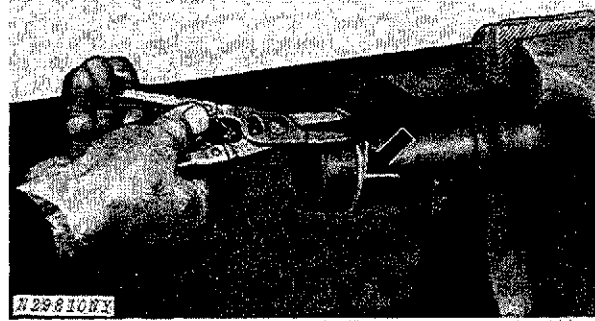
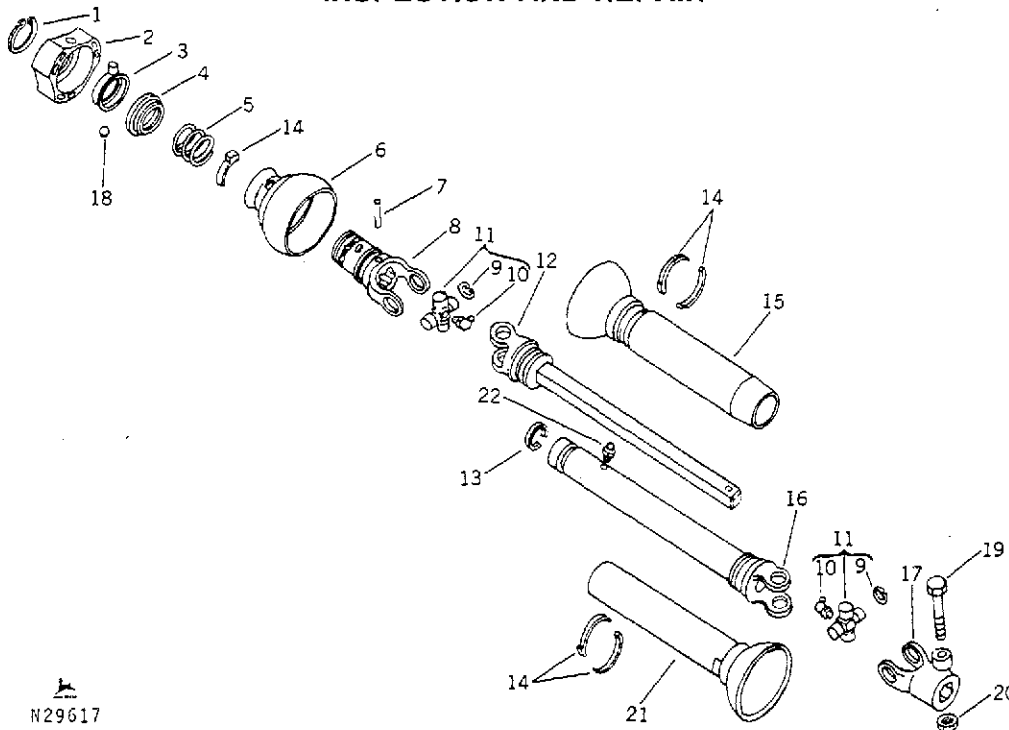

Fig. 8-Removing Nylon Bearing

INSPECTION AND REPAIR



N29617

- 1—Snap Ring
- 2—Push Collar
- 3—Push-Button Latch
- 4—Collar Retainer
- 5—Spring
- 6—Closure Shield
- 7—Spring Pin

- 8—Push-Button Yoke
- 9—Snap Ring, 2 used
- 10—Grease Fitting, 2 used
- 11—Spider and Bearing Assembly, 2 used
- 12—Yoke and Shaft
- 13—Bearing
- 14—Bearing, 9 used

- 15—Front Shield
- 16—Yoke and Tube
- 17—Yoke
- 18—Steel Ball, 3 used
- 19—Cap Screw
- 20—Nut
- 21—Rear Shield
- 22—Grease Fitting

Fig. 9-Powershaft

Check the spider and bearing assembly (11, Fig. 10) for wear. Replace if defects are found.

Check the yoke tube (16) and yoke shaft (12) for straightness. Replace if defects are found.

Check the compression spring (5) for cracks or rust. Replace if defects are found.

Check the nylon locking bearings (14) for wear. Replace if defects are found.

ASSEMBLY

1. Liberally apply molydisulfide grease (black) to all grooves that have nylon bearings. If the nylon bearings are stiff, soak them in boiling water for several minutes to soften them.

2. Install the nylon bearing in the yoke and tube (Fig. 8).

3. Install the spider and bearing assemblies (Fig. 7).

4. Install retaining rings (Fig. 6).

5. Install rear shield (Fig. 5).

6. Install front closure shield (Fig. 4).

7. Install collar retainer (Fig. 3).

8. Install snap ring (Fig. 2).

9. Grease the entire shaft before sliding the two parts together; then lubricate all grease fittings with two or three pumps of the grease gun. (See page 5.)

NOTE: When sliding the shaft into the rear section, make sure the yokes are phased correctly (see below) or vibration and damage can result.

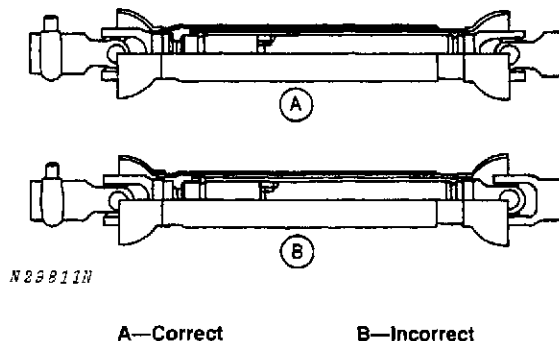

Fig. 10-Powershaft Phasing

GEAR CASE AND SLIP CLUTCH

GENERAL INFORMATION

The seeder gear case is made up of two beveled gears—a 20-tooth gear and a 27-tooth gear. The grass model, designed for a 540 rpm PTO, has the 27-tooth gear on the input shaft. The grain model, designed for a 1000 rpm PTO, has the 20-tooth gear on the input shaft of the gear case.

A double-disk slip clutch is located on the gear case output shaft to protect the gear case and units.

Remove the gear case for disassembly and repair if it leaks oil, is noisy, or will not turn. Remove the slip clutch to replace the disks, bearings, clutch face, or clutch sprocket. (See page 19.)

GEAR CASE REMOVAL

1. Remove the powershaft (Fig. 1).

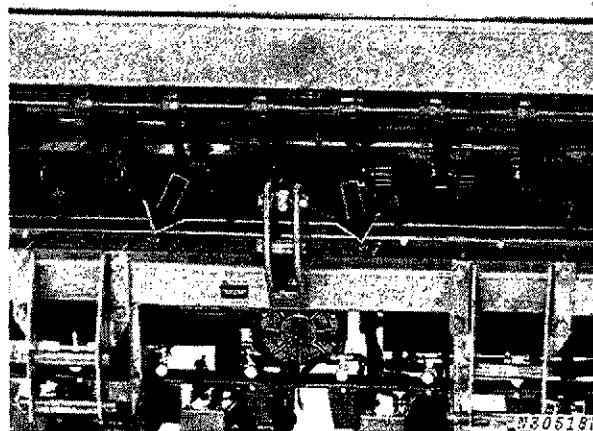
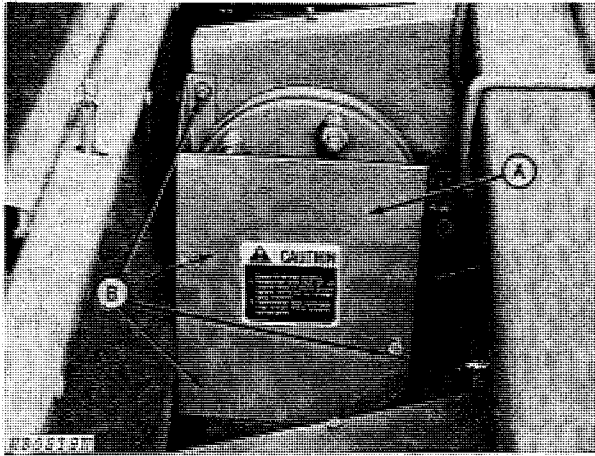

Fig. 11-Removing Top Shield

2. Remove the gear case top shield by taking off the two wing nuts (Fig. 11) and lifting off the shield.



A—Shield

B—Nuts

Fig. 12-Removing Main Drive Shield

3. Remove the main drive shield (A, Fig. 12) by taking out the four bolts (B) holding it to the frame.

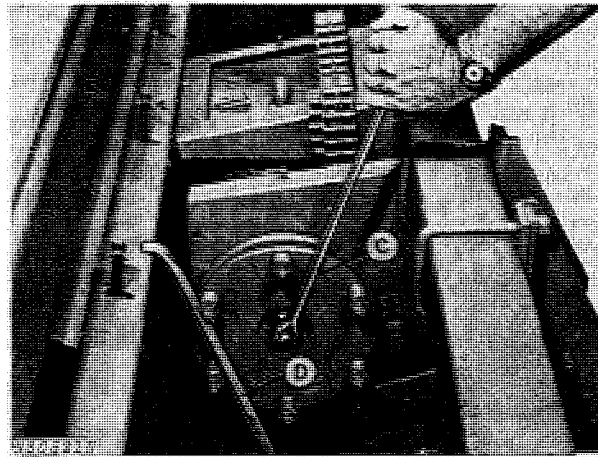

C—Socket Wrench

D—Bar

Fig. 14-Removing Clutch and Sprocket

5. Remove 5/8" nut securing the clutch and sprocket assembly to the shaft with a 15/16-inch socket wrench (C, Fig. 14), using a bar (D) to hold the assembly. See page 19 for clutch disassembly.

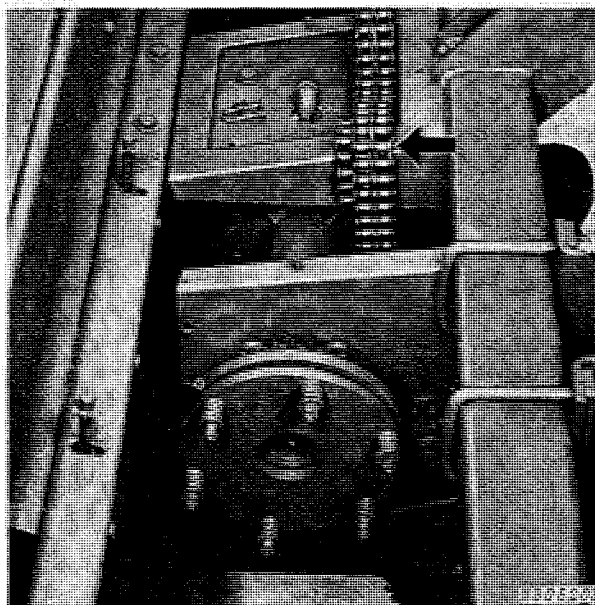
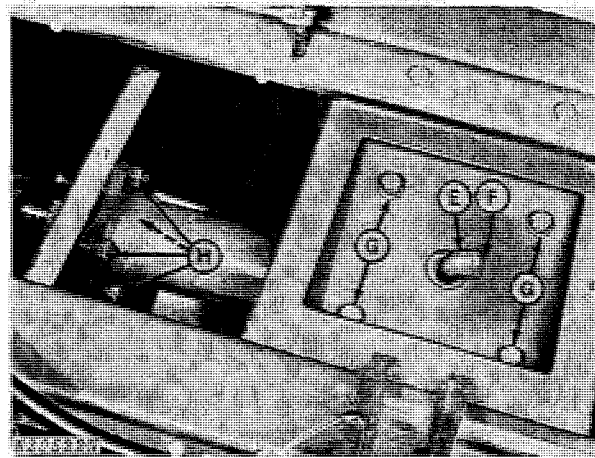

Fig. 13-Removing Chain

4. Remove the drive chain (Fig. 13) by first loosening the tightener sprocket, then separating the chain at the connector link.

Examine chain for excessive wear or damage. Replace as necessary.



E—Elbow
F—Breather

G—Gear Case Bolts
H—Neck Bolts

Fig. 15-Loosening Gear Case

6. Use a hex socket wrench to remove the breather (F, Fig. 15) from the elbow (E). Then remove the elbow from the gear case. Install the breather back in the hole to prevent oil from spilling accidentally.

7. Loosen (one turn) the gear case bolts (G), then remove the neck bolts (H).



Suggest:

If the above button click is invalid.

Please download this document

first, and then click the above link

to download the complete manual.

Thank you so much for reading

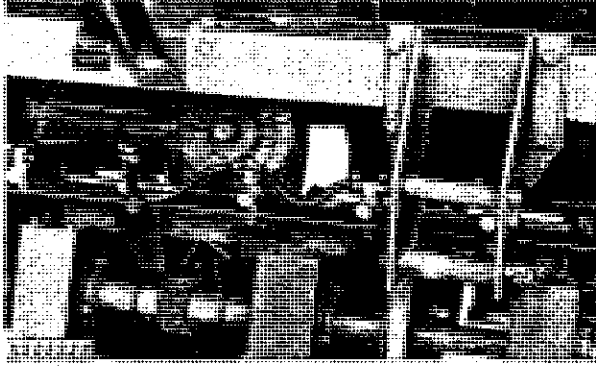

Fig. 16-Removing Gear Case

8. Lay a 4x4-inch (102 x 102 mm) wooden block (or something similar) on top of the cutter wheel units—under the gear case (Fig. 16). Completely remove the four gear case bolts (G, Fig. 15) and allow the gear case to drop onto the block.

⚠ CAUTION: The gear case weighs approximately 75 pounds (34 kg). Be careful when removing it.

Slide the gear case to the left on the block and lift it out of the seeder.

NOTE: When reinstalling the gear case, use the block to raise the gear case high enough to insert the bolts.

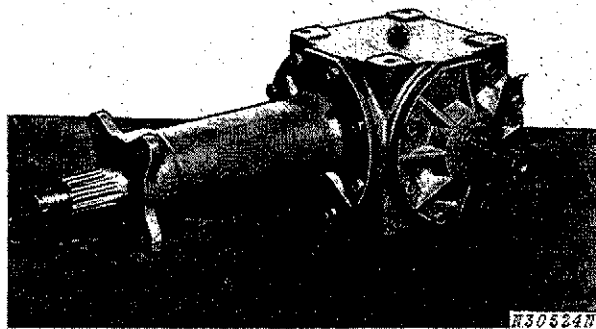

Fig. 17-Gear Case

9. Place the gear case on a bench or table in a well lighted work area (Fig. 17).

10. Drain the oil from the gear case.

GEAR CASE DISASSEMBLY

Output Shaft

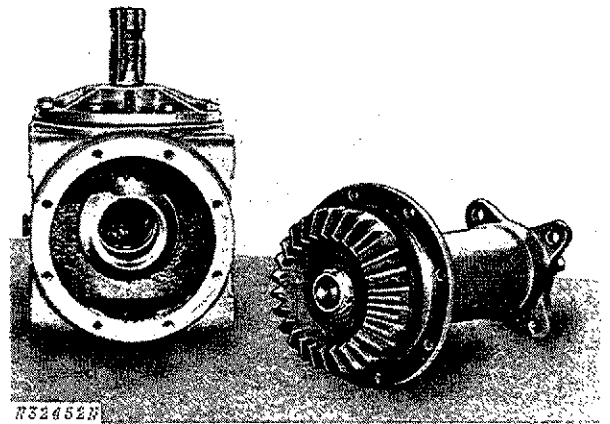

Fig. 18-Output Assembly Removed

1. Remove the eight bolts securing the output shaft assembly to the gear case to separate it from the gear case (Fig. 18).

NOTE: Either the input or output shaft assembly can be removed from the gear case first.

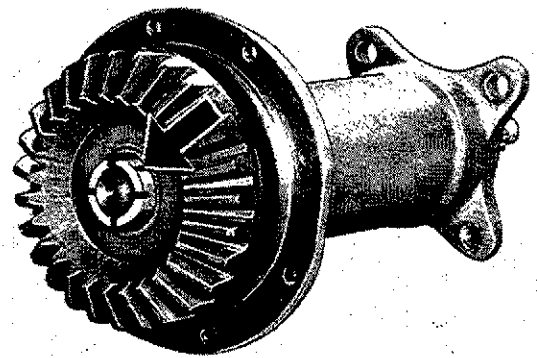

Fig. 19-Removing Nut

2. Use a hammer and punch to remove the notched nut (Fig. 19). Strike the punch sharply to loosen the nut. If necessary, clamp the gear in a vise, being careful not to damage the gear teeth.

<https://www.ebooklibonline.com>

Hello dear friend!

Thank you very much for reading.

Enter the link into your browser.

The full manual is available for immediate download.

<https://www.ebooklibonline.com>