

JOHN DEERE
WORLDWIDE COMMERCIAL & CONSUMER
EQUIPMENT DIVISION

Sabre Lawn Tractors
1438GS, 1438HS, 1538HS, and 1542HS
1742GS, 1742HS and 2046HS

OPERATOR'S MANUAL



OMGX10526 G9

North American
Litho in U.S.A.

English

INTRODUCTION

THANK YOU for purchasing a John Deere product.

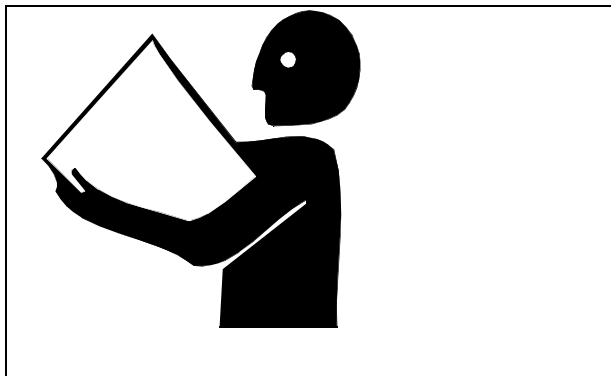

Read this manual and your attachment manual thoroughly. Failure to do so could result in personal injury or equipment damage.



WARNING: The Engine Exhaust from this product contains chemicals known to the State of California to cause cancer, birth defects or other reproductive harm.

CALIFORNIA Proposition 65 Warning

This manual should be considered a permanent part of your machine and should remain with the machine when you sell it.

Product warranty is provided as part of John Deere's support program for customers who operate and maintain their equipment as described in this manual. The product warranty is explained on the warranty certificate you received from your dealer.

Measurements in this manual are metric units and their U.S. customary equivalents. RIGHT-HAND and LEFT-HAND sides are determined by facing in the direction the machine will travel when going forward. When you see a broken line arrow (----->), it indicates the part it is pointing to is hidden.

Record identification numbers below. Be sure to record all the numbers to help in tracing the machine if it is stolen. You also need to give these numbers to your dealer when you order parts.

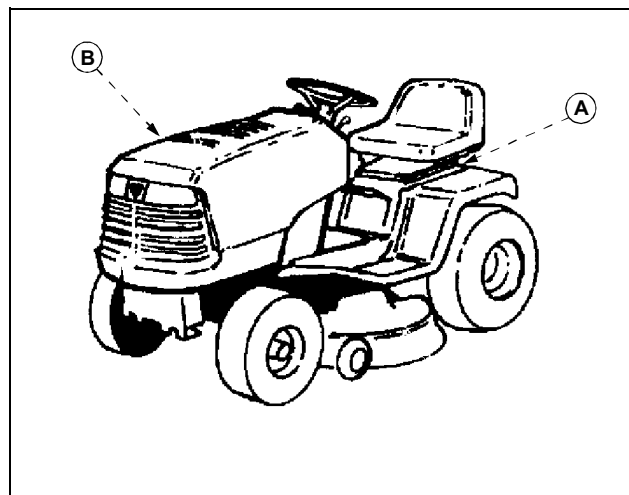

DATE OF PURCHASE:

DEALER NAME:

DEALER PHONE:

TRACTOR SERIAL NUMBER (A), (Under seat):

ENGINE SERIAL NUMBER (B), (Right side of engine):

Sabre® is a registered trademark of Deere & Company

TABLE OF CONTENTS

Contents

Assembly	1
Safety Signs.....	3
Controls	5
Operating the Machine	7
Operating the Mower	18
Replacement Parts	24
Service Machine Safely	25
Service Interval Chart.....	26
Service Engine	28
Service Steering and Brakes	35
Service Mower.....	38
Service Electrical	44
Service Miscellaneous.....	48
Removing Mower.....	52
Installing Mower.....	53
Troubleshooting	55
Storing Machine.....	59
Specifications.....	61
Warranty	64
Index	67
Service Literature	69

All information, illustrations and specifications in this manual are based on the latest information at the time of publication. The right is reserved to make changes at any time without notice.

English

COPYRIGHT© 1999
Deere & Co.
John Deere Worldwide Commercial and
Consumer Equipment Division
Horicon, WI
All rights reserved
Previous Editions
COPYRIGHT© 1998, 1997, 1996

OMGX10526 G9

<https://www.ebooklibonline.com>

Hello dear friend!

Thank you very much for reading.

Enter the link into your browser.

The full manual is available for immediate download.

<https://www.ebooklibonline.com>

ASSEMBLY

Identify Parts

- A Operator's Manual
- B Safety Video
- C Bag of Hardware
- D Key

Bag of Hardware:

- 2 - M8x16 Bolts - Battery
- 2 - M8x16 Nuts - Battery

Connect and Check Battery



CAUTION: Avoid injury. Prevent Battery Explosions:

- Keep sparks, lighted matches, and open flame away from the top of battery. Battery gas can explode.

- Never check battery charge by placing a metal object across the posts. Use a volt-meter or hydrometer.

- Do not charge a frozen battery; it may explode. Warm battery to 16° C (60° F)

IMPORTANT: Avoid machine damage. This battery comes fully charged. If the mower is not used by the Service Expiration Date indicated on the battery, charge the battery. (See Charging the Battery in the Service - Electrical section.)

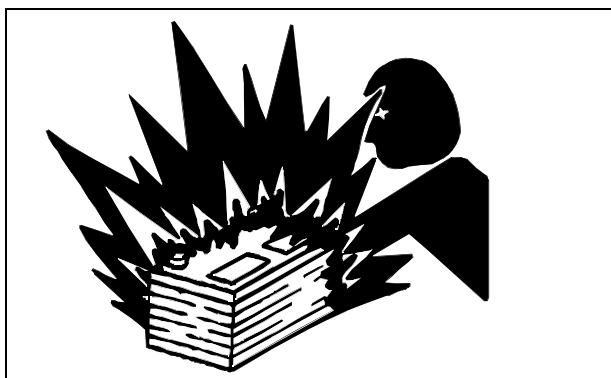

CAUTION: Avoid injury. DO NOT attempt to open, add fluid or service battery. Any attempt to do so will void warranty and lead to possible injury.

NOTE: Do not remove the BLACK negative (-) protective cap at this time.

1. Remove and discard the RED positive (+) protective cap from the positive (+) battery terminal.

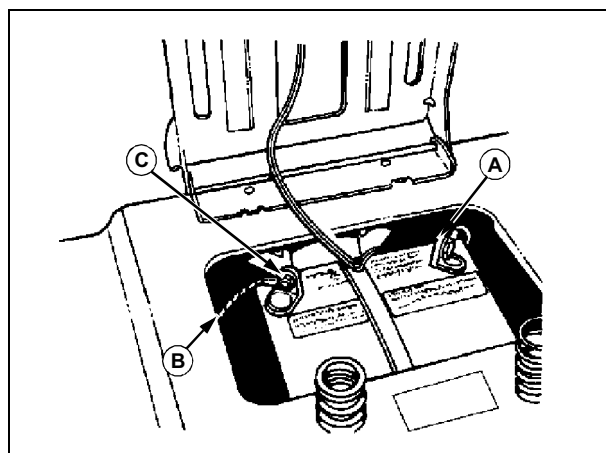

2. Connect RED positive (+) cable (A) to battery with 6mm hex head bolt and 6 mm flange nut. Tighten securely. Apply petroleum jelly or silicone spray to terminal to prevent corrosion. Install the red terminal cover.

3. Remove and discard the BLACK (-) protective cap from the negative battery terminal.

4. Connect silver braided grounding cable (B) to the negative (-) terminal (C) with remaining 6 mm hex head bolt and 6 mm flange nut and tighten securely. Apply petroleum jelly or silicone spray to terminal to prevent corrosion.

42-Inch Mowers Only



CAUTION: Avoid injury. Never operate the mower without the discharge chute guard in place.

- If tractor/mower deck is being set-up for mulching, install mulch cover kit. (See Using Mower Deck Mulch Ready in the Operating Mower section.)
- If tractor/mower deck is being set-up for side discharger or 2-bag bagger DO NOT install mulch cover kit. (See Using Mower Deck Side Discharge OR Using Mower Deck

ASSEMBLY

with Optional Equipment in the Operating Mower section.)

Checking Tire Pressure



CAUTION: Avoid injury. Explosive separation of a tire and rim parts can cause serious injury or death:

- Do not attempt to mount a tire without the proper equipment and experience to perform the job.
- Always maintain the correct tire pressure. Do not inflate the tires above the recommended pressure. Never weld or heat a wheel and tire assembly. The heat can cause an increase in air pressure resulting in a tire explosion. Welding can structurally weaken or deform the wheel.
- When inflating tires, use a clip-on chuck and extension hose long enough to allow you to stand to one side and NOT in front of or over the tire assembly.
- Check tires for low pressure, cuts, bubbles, damaged rims or missing lug bolts and nuts.

1. Check tires for damage.
2. Check tire pressure with an accurate gauge.
3. Add or remove air, if necessary:

Tire Size	Pressure-kPa (psi)
Front: 15-Inch	97 kPa (14 psi)
Rear: 20-Inch	69 kPa (10 psi)

SAFETY SIGNS

Safety-Alert Symbol

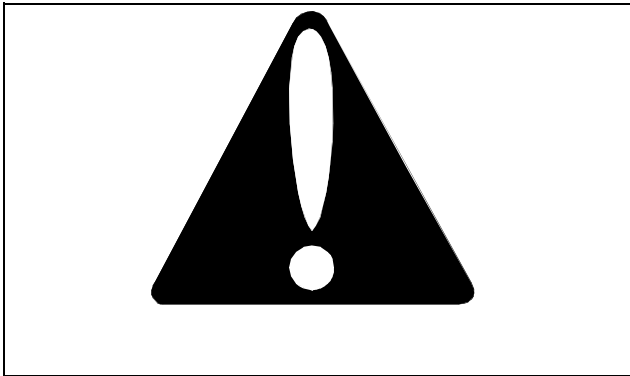

Read and recognize safety information. Be alert to the potential for personal injury when you see this safety-alert symbol.

On your machine safety labels, the words DANGER, WARNING, and CAUTION are used with this safety-alert symbol. DANGER identifies the most serious hazards.

In this manual, the word CAUTION and this symbol call attention to safety messages.

Certification

Your mower has been certified by an independent laboratory for compliance with American National Standard B-71.1, "Safety Specifications" for Power Lawn Mowers, Lawn and Garden Tractors, and Lawn Tractors.

Machine Safety Labels

DANGER

AVOID SERIOUS INJURY OR DEATH

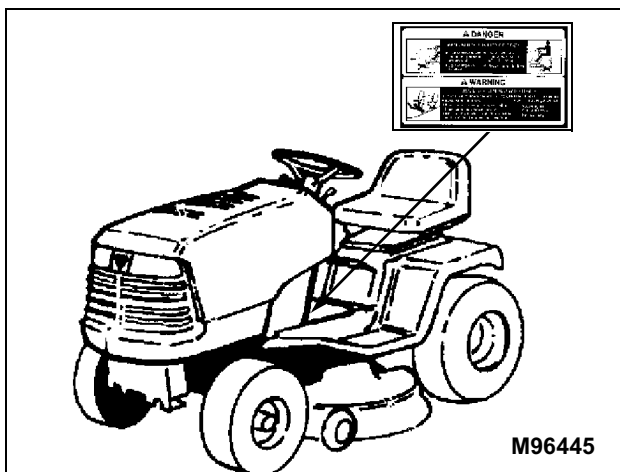

- Do not mow when children or others are around

- Do not mow in reverse
- Look down and behind before and while backing
- Never carry children

WARNING

AVOID SERIOUS INJURY OR DEATH

- Drive up and down slopes, not across
- Avoid sudden turns
- If machine stops going uphill, stop blade and back down slowly
- Keep safety devices (guards, shields, and switches) in place and working
- Read operator's manual
- When leaving machine:

–Stop engine

–Set park brake

–Remove key

DANGER/POISON

SHIELD EYES.

EXPLOSIVE GASES CAN CAUSE BLINDNESS OR INJURY.

NO

- SPARKS
- FLAMES
- SMOKING

SULFURIC ACID CAN CAUSE BLINDNESS OR SEVERE BURNS

FLUSH EYES IMMEDIATELY WITH WATER.

GET MEDICAL HELP FAST.

MAINTENANCE-FREE

KEEP OUT OF THE REACH OF CHILDREN. DO NOT TIP. DO NOT OPEN BATTERY!

SAFETY SIGNS

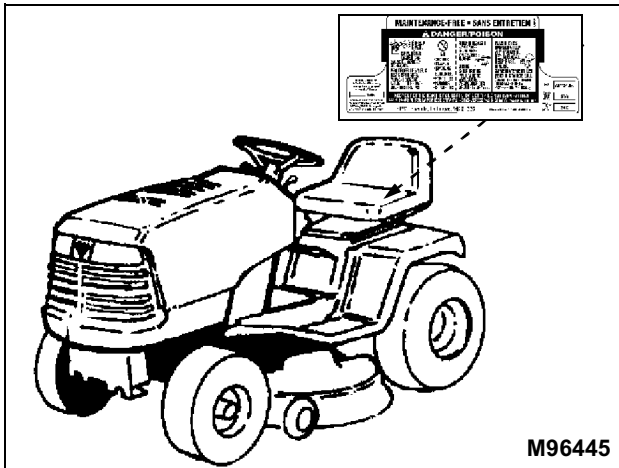

Picture Note: Located on Battery under seat

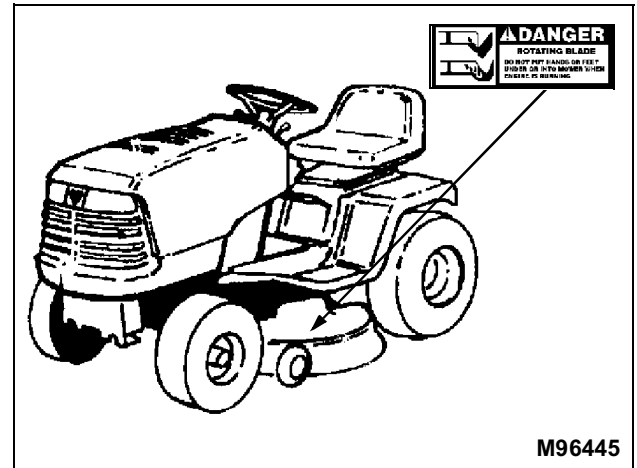

Picture Note: Located on Left-Hand side of deck

DANGER

ROTATING BLADE

DO NOT PUT HANDS OR FEET UNDER OR INTO MOWER WHEN ENGINE IS RUNNING

THROWN OBJECTS

BEFORE MOWING, CLEAR AREA OF OBJECTS THAT MAY BE THROWN BY BLADE

DO NOT OPERATE MOWER WITHOUT DISCHARGE CHUTE OR ENTIRE GRASS CATCHER IN PLACE

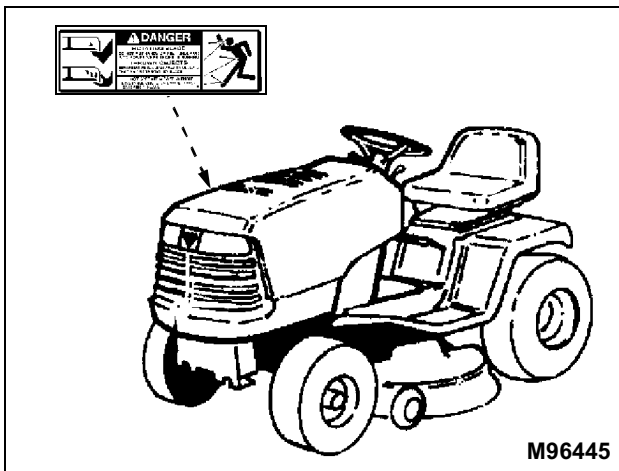

Picture Note: Located on Right-Hand side of deck

DANGER

ROTATING BLADE

DO NOT PUT HANDS OR FEET UNDER OR INTO MOWER WHEN ENGINE IS RUNNING

CONTROLS

Tractor Controls - Gear

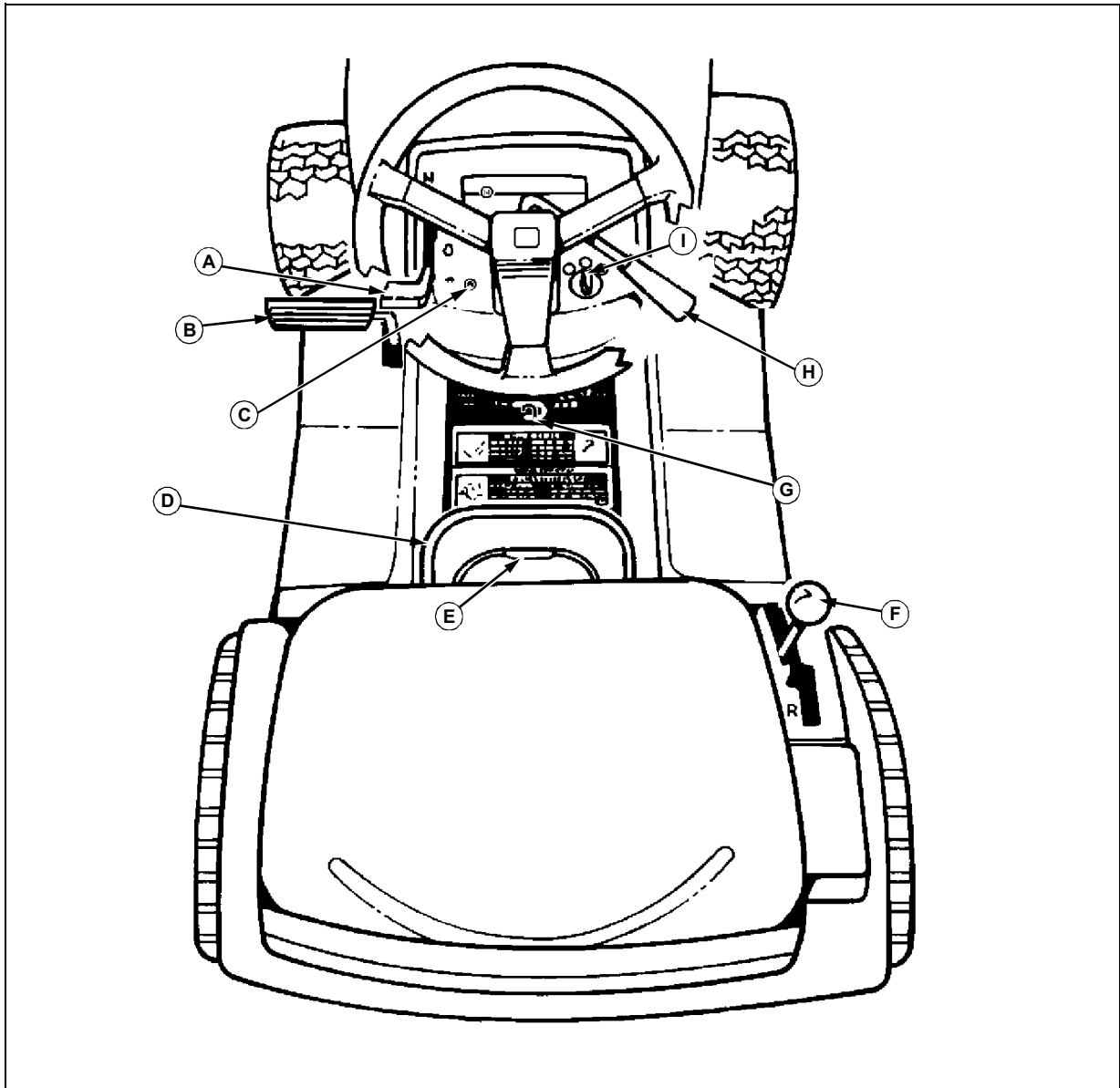

A - Throttle/Choke Control

B - Foot Pedal - Brake/Clutch

C - Reverse Implement Option Switch

D - Attachment Lift Lever

E - Locking Lever

F - Transmission Shift Lever

G - Park Brake

H - PTO Drive Lever

I - Ignition Switch

Tractor Controls - Automatic

CONTROLS

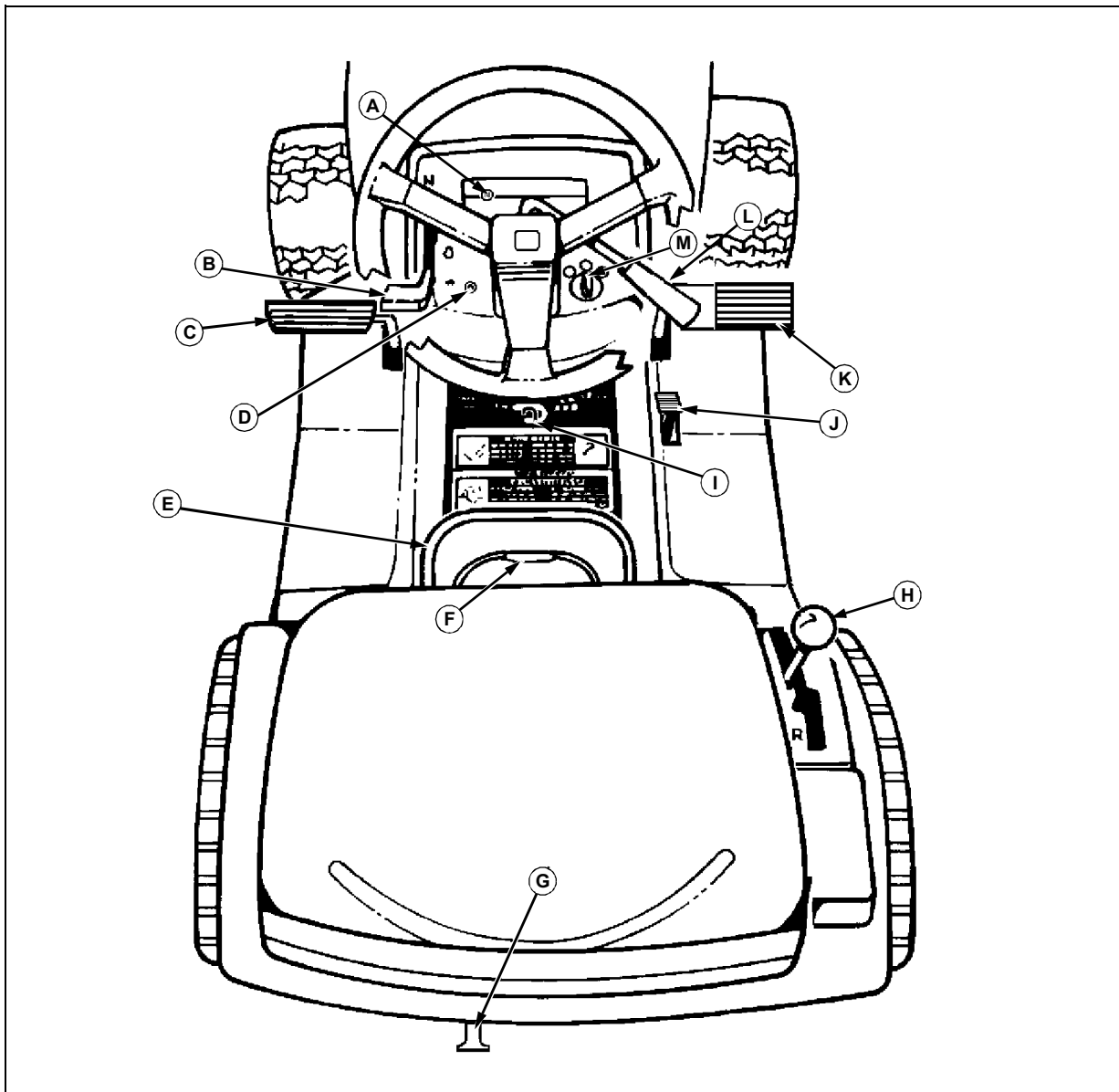

- | | |
|--|---|
| A - Choke Knob (V-Twin) | Only) |
| B - Throttle/Choke Control (Single Cylinder) | I - Park Brake |
| C - Foot Pedal - Brake/Return to Neutral | J - Foot Pedal, Reverse (Foot Control Units Only) |
| D - Reverse Implement Option Switch | K - Foot Pedal, Forward (Foot Control Units Only) |
| E - Attachment Lift Lever | L - PTO Drive Lever |
| F - Locking Lever | M - Ignition Switch |
| G - Free Wheeling Knob | |
| H - Hand Lever: | |
| - Transmission Shift Lever (Hand Control Units Only) | |
| - Cruise Control Lever (Foot Control Units | |

OPERATING MACHINE

Operate Safely

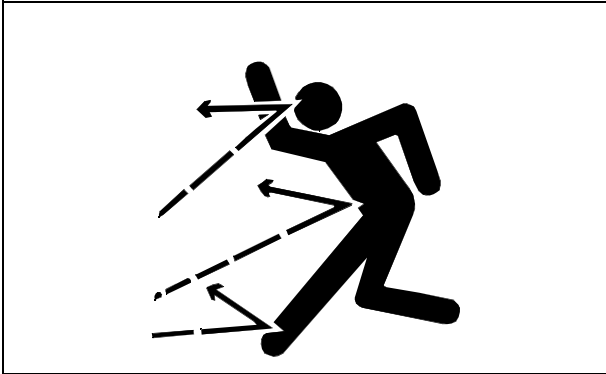

- In addition to reading your Operator's Manual, view your Mowing Safety Video.
- Check brake action before you operate. Adjust or service brakes as necessary.
- Inspect machine before you operate. Be sure hardware is tight. Repair or replace damaged, badly worn, or missing parts. Be sure guards and shields are in good condition and fastened in place. Make any necessary adjustments before you operate.
- Clear work area of objects that might be thrown. Keep people and pets out of the work area. Stop machine if anyone enters the area.
- If you hit an object, stop the machine and inspect it. Make repairs before you operate. Keep machine and attachments properly maintained and in good working order.
- DO NOT leave machine unattended when it is running.
- Only operate during daylight or with good artificial light.
- Be careful of traffic when operating near or crossing roadways.
- Do not wear radio or music headphones while operating the machine. Safe operation requires your full attention.
- Older adults are involved in a large percentage of riding mower accidents involving injury. These operators should evaluate their ability to operate a mower safely enough to protect the operator and others from serious injury.

Park Safely

- Stop machine on a level surface, not on a slope.
- Disengage mower blades.
- Lower attachments to the ground.
- Engage park brake.
- STOP engine.
- Remove key.

- Before you leave the operator's seat, wait for engine and all moving parts to STOP.

Rotating Blades are Dangerous - Protect Children and Prevent Accidents

PROTECT CHILDREN:

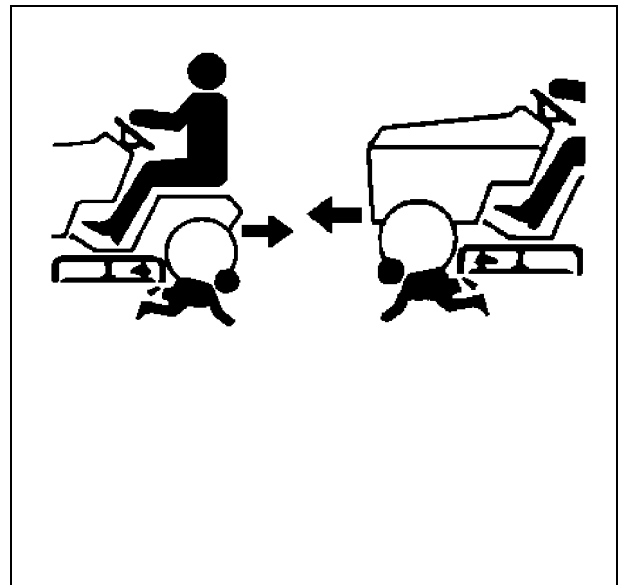

- Never assume that children will remain where you last saw them. Children are attracted to mowing activity, stay alert to the presence of children.
- Keep children in the house when you are operating the machine.
- Turn machine off if a child enters the mowing area.
- Use extra care when you come to blind corners, shrubs, trees, or other objects that may block your vision.
- DO NOT let children or an untrained person operate the machine.
- DO NOT carry or let children ride on machine or any attachment. DO NOT tow children in a cart or trailer.

HELP PREVENT SERIOUS OR FATAL ACCIDENTS:

- Be alert at all times, drive forward carefully. People especially children can move quickly into the mowing area before you know it.
- Back carefully. Disengage mower blades and look behind the machine carefully, especially for children, before you back up.
- DO NOT mow in reverse unless it is absolutely necessary.
- Disengage mower blades when you are not mowing.
- DO NOT operate machine if you are under the influence

OPERATING MACHINE

of drugs or alcohol.

Avoid Tipping

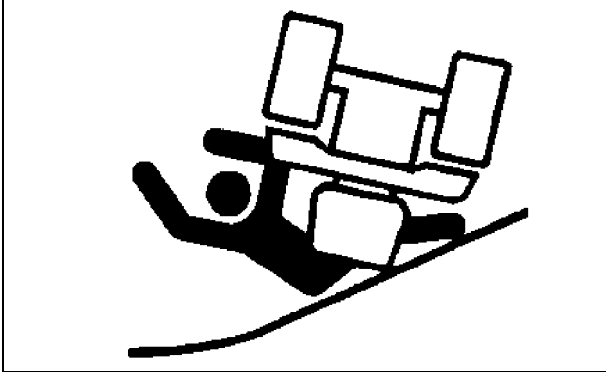

- DO NOT drive where machine could slip or tip.
- Stay alert for holes and other hidden hazards in the terrain.
- Keep away from drop-offs.
- Slow down before you make a sharp turn or operate on a slope.
- When pulling loads or using heavy equipment, use only approved hitches, limit loads to those you can safely control, and use counterweights or wheel weights when required per this manual or your attachment manual.
- Drive up and down a hill—not across. Be careful when you change direction on a slope.
- DO NOT stop when going up hill or down hill. If machine stops going up hill, DISENGAGE mower blades and back down slowly.
- DO NOT mow wet grass. Reduced traction could cause sliding.
- DO NOT try to stabilize the machine by putting your foot on the ground.

Keep Riders Off

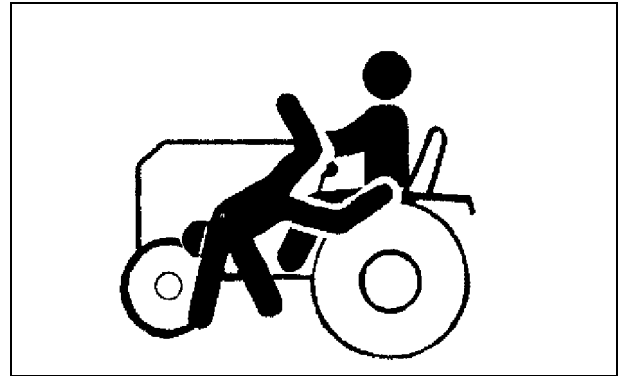

- Only allow the operator on the machine. Keep riders off.
- Riders on the machine or attachment may be struck by foreign objects or thrown off the machine causing serious injury.
- Riders obstruct the operator's view resulting in the machine being operated in an unsafe manner.

Wear Appropriate Clothing

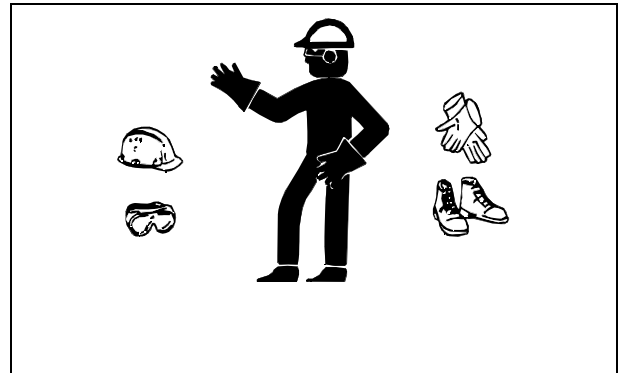

- Wear close fitting clothing and safety equipment appropriate for the job.
- Loud noise can cause impairment or loss of hearing, wear a suitable protective device such as earplugs.

OPERATING MACHINE

Transport Safely

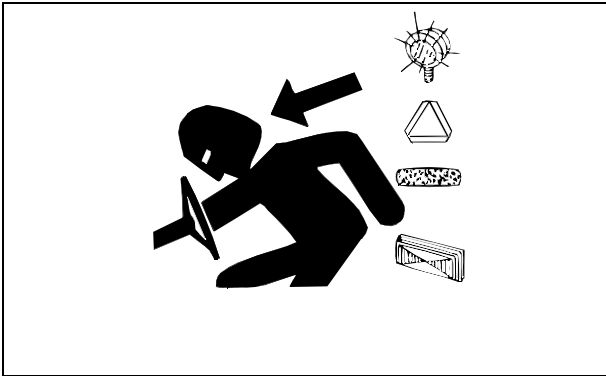

- Use safety lights and devices. Slow moving machines when driven on public roads are hard to see, especially at night. Avoid personal injury or death resulting from a collision with a vehicle.
- Whenever driving on public roads, use flashing warning lights and turn signals according to local regulations. Extra flashing warning lights may need to be installed.

Adjusting Seat

1. Pivot seat forward on its mounting bracket.

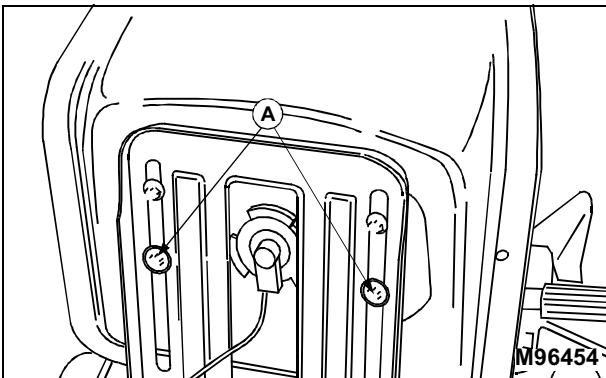

Picture Note: Model with capscrew adjuster used for illustration.

2. Loosen two cap screws (A) two turns.
3. Slide forward or rearward on mounting bracket to desired position.
4. Tighten cap screws or knobs.
5. Lower seat.

Using Slide Adjuster (V-Twin Only)

1. Pivot seat forward on its mounting bracket.

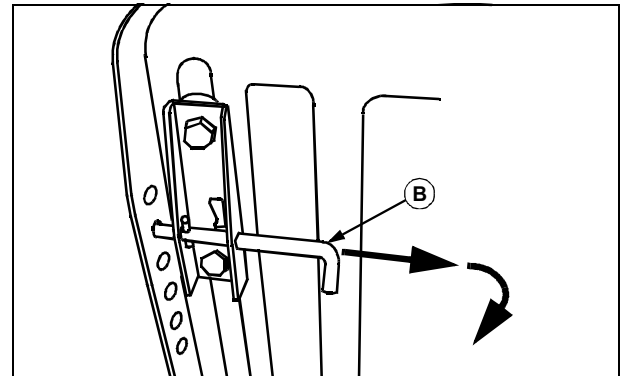

2. Pull pin (B) and rotate pin to the locked position.
3. Slide seat forward or rearward to desired position.
4. Release pin, make sure pin engages in hole in frame.

Using the Park Brake



CAUTION: Avoid injury, always **LOCK** park brake before getting off tractor or leaving tractor unattended.

LOCKING PARK BRAKE:

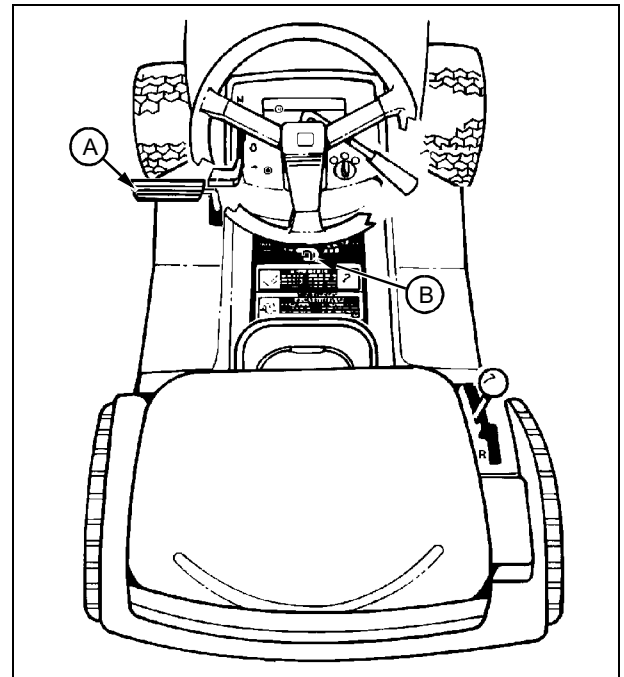

1. Push and hold foot pedal (A) all the way down.
2. Move park brake lever (B) forward, then to the left to lock position.
3. Remove foot from pedal. Pedal should not return to the

OPERATING MACHINE

up position.

UNLOCKING PARK BRAKE

1. Push and hold foot pedal (A) all the way down.
2. Move park brake lever (B) to the right, then to the rear.
3. Remove foot from pedal. Pedal should return to the up position.

Starting Engine



CAUTION: Avoid injury. Start engine **ONLY** outdoors or in a well ventilated place. Exhaust fumes are dangerous.

IMPORTANT: Avoid machine damage. Do not operate starter more than 20 seconds at a time, or you may damage it. If engine does not start: Wait two minutes before you try again. See Troubleshooting section.

NOTE: Engine will not start unless: PTO lever is **DISENGAGED**, park brake is **LOCKED** or brake pedal pushed down. On **GEAR** model: The transmission shift lever should be in **N (NEUTRAL)** position.

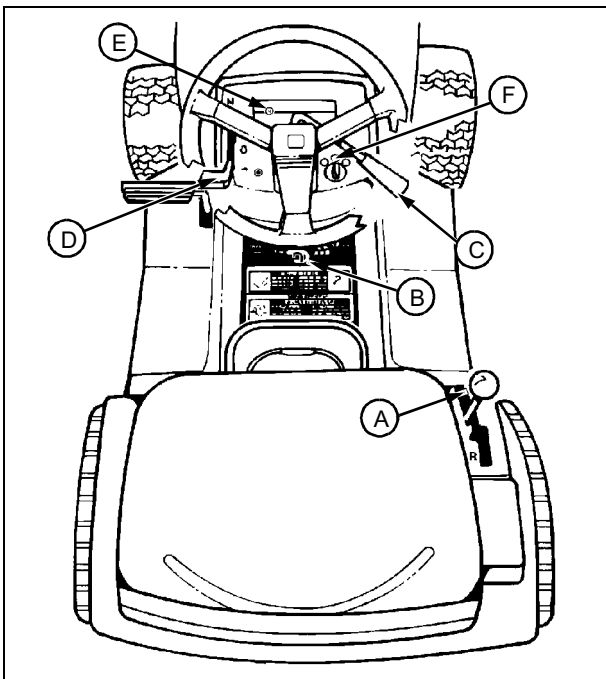

1. **Gear units** - Move transmission shift lever (A) to N (NEUTRAL) position.

Automatic units - If equipped with shift lever, move shift lever to N (NEUTRAL) position. If equipped with foot pedal

controls, do not depress either pedal.

2. Lock the park brake (B).
3. Pull PTO lever (C) all the way back to the rearward (OFF) position.
4. To start the engine:
 - Place the throttle lever (D) or (E) in the CHOKE (☒) position. As the engine begins to run smoothly, lower the throttle lever in small steps, allowing the engine to accept changes in speed and load, until the throttle lever is in the FAST (☑) position.
5. Turn ignition key (F) to start position to crank the engine. Crank engine until it starts, but no longer than 5 seconds.
6. If engine starts, release key to run position. If engine does not start, release key to run position and wait 10 seconds before cranking the engine again.
7. Let engine run for a couple of minutes to warm-up before operating tractor.

Using Throttle Control

Always operate the engine at FULL (☑) THROTTLE.

Operating the engine at less than full throttle reduces the battery charging rate and reduces fan cooling efficiency of the engine.

Full throttle offers the best bagging and mower performance.

Cold Weather Starting Tips

Always use fresh winter grade fuel.

Do not crank engine for more than 30 seconds in any single attempt.

During first minute of operation engine may be operated in partial choke to allow smoother running. As engine warms slowly reduce engine speed to the full throttle detent position.

On Automatic Transmission

Allow engine to run for a few minutes before using tractor to allow automatic transmission oil to warm. Sluggish transmission response in cold weather indicates that oil has not warmed to allow optimum performance.

Warming and Idling Engine

WARMING ENGINE:

- Run Engine at half speed for 2–3 minutes.



Suggest:

If the above button click is invalid.

Please download this document

first, and then click the above link

to download the complete manual.

Thank you so much for reading

OPERATING MACHINE

IDLING ENGINE:

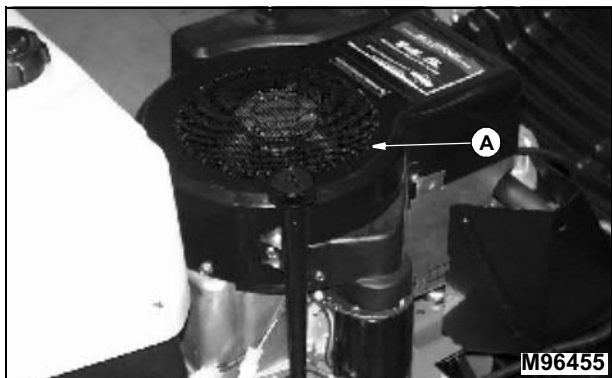

- Engine is air-cooled and needs a large volume of air to keep cool. Keep air intake screen (A) on top of engine clean.
- Avoid unnecessary engine idling.

Stopping Engine

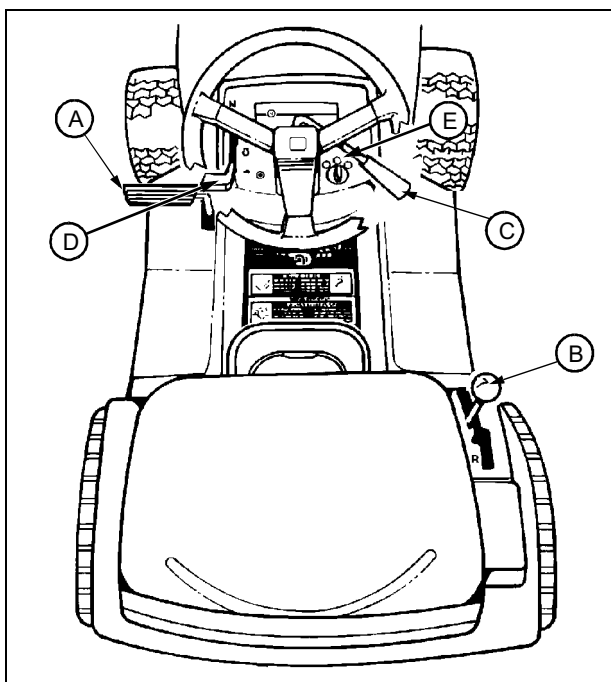

1. Push down on foot pedal (A).
2. **Gear units** - Move transmission shift lever (A) to N (NEUTRAL) position.
Automatic units - If equipped with shift lever, move shift lever to N (NEUTRAL) position. If equipped with foot pedal controls, release either pedal and unit will automatically return to neutral. If cruise control is engaged, move lever to OFF position.
3. Pull PTO lever (C) all the way back to the rearward

(OFF) position.

4. Move throttle lever (D) to SLOW (t) position. Let engine run at low throttle a few seconds.
5. Turn key (E) to OFF position.
6. Remove key.
7. LOCK the park brake.

Using Travel Controls - Gear



CAUTION: Avoid injury:

- Before moving forward or rearward, make sure area is clear of bystanders, especially children.
- Disengage mower or attachment before backing up.

TO TRAVEL FORWARD:

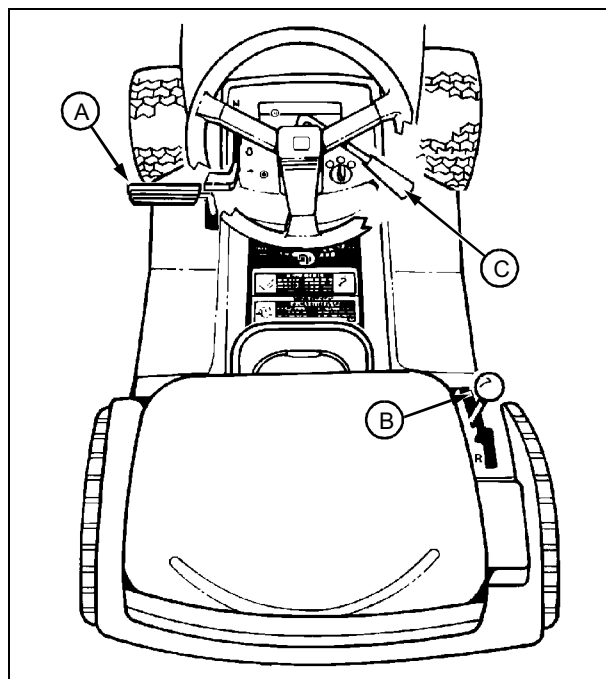

1. Push foot pedal (A) all the way forward to the BRAKE position.
2. Move shift lever (B) to the right and forward to desired FORWARD position.
3. Slowly release foot pedal to engage machine drive.

TO TRAVEL IN REVERSE:

NOTE: *The engine and mower will stop as the shift lever is moved to the R (REVERSE) position with mower engaged.*

1. Push foot pedal (A) all the way down to STOP tractor.

<https://www.ebooklibonline.com>

Hello dear friend!

Thank you very much for reading.

Enter the link into your browser.

The full manual is available for immediate download.

<https://www.ebooklibonline.com>