

# 1380 Mower-Conditioner



JOHN DEERE

## TECHNICAL MANUAL 1380 Mower-Conditioner

TM1204 (01SEP78) English

**TM1204 (01SEP78)**

LITHO IN U.S.A. (NEW)  
ENGLISH



# 1380 MOWER-CONDITIONER

## TECHNICAL MANUAL

### TM-1204 (SEP-78)

#### CONTENTS

INTRODUCTION

SAFETY

SECTION 10 - GENERAL

- Group 5 - Specifications
- Group 10 - Diagnosing Malfunctions
- Group 15 - Description
- Group 20 - Lubrication

SECTION 20 - PLATFORM

- Group 5 - General Information and Removal
- Group 10 - Reel
- Group 15 - Auger
- Group 20 - Conditioner
- Group 25 - Right-Hand and Left-Hand Cross Shaft

SECTION 30 - HYDRAULIC SYSTEM

- Group 5 - General Information, Diagnosis and Tests
- Group 10 - Hydraulic Pump and Planetary Gear Case
- Group 15 - Hydraulic Motor
- Group 20 - Relief Valve, Shutoff Valve and Filter
- Group 25 - Pivot Cylinder
- Group 30 - Hydraulic Lift System

SECTION 40 - CUTTING COMPONENTS

- Group 5 - Knife Drive Case
- Group 10 - Cutterbars
- Group 15 - Knives

SECTION 50 - MISCELLANEOUS

- Group 5 - Wheels
- Group 10 - Tongue

SECTION 60 - ALPHABETICAL INDEX

All information, illustrations and specifications contained in this technical manual are based on the latest information available at the time of publication. The right is reserved to make changes at any time without notice.

Because John Deere sells its products world-wide, U.S. units of measure are shown with their respective Metric equivalents throughout this technical manual. These equivalents are the SI (International System) Units of Measure.

Copyright© 1978  
DEERE & COMPANY  
Moline, Illinois  
All rights reserved

## INTRODUCTION

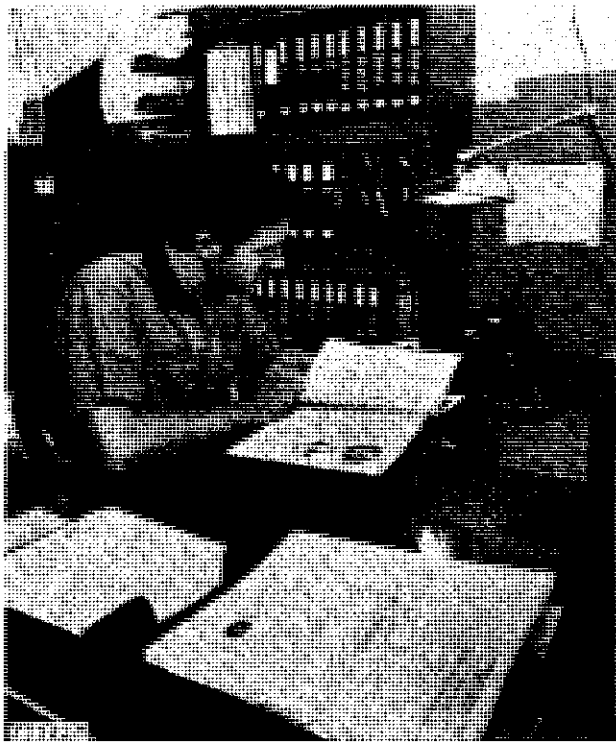

Use FOS Manuals for Reference

This technical manual is part of a twin concept of service:

The two kinds of manuals work as a team to give you both the general background and technical details of shop service.

### •FOS Manuals—for reference

*Fundamentals of Service (FOS) Manuals* cover basic theory of operation, *fundamentals* of trouble shooting, *general* maintenance, and *basic* types of failure and their causes. FOS Manuals are for training new people and for reference by experienced technicians.



When a service technician should refer to FOS Manual for more information, a FOS symbol like the one at the left is used in the TM to identify the reference.

### •Technical Manuals—for actual service

*Technical Manuals* are concise service guides for a *specific* machine. Technical manuals are on-the-job guides containing only the vital information needed by an experienced technician.



Use Technical Manuals for Actual Service

Some features of this technical manual:

- *Table of contents at front of manual*
- *Exploded views showing parts relationship*
- *Photos showing service techniques*
- *Specifications grouped for easy reference*

This technical manual was planned and written for you—a service technician. Keep it in a permanent binder in the shop where it is handy. Refer to it whenever in doubt about correct service procedures or specifications.

Using the technical manual as a guide will reduce error and costly delay. It will also assure you the best in finished service work.

### SI (INTERNATIONAL SYSTEM) UNITS OF MEASURE

Because John Deere sells its products world-wide, U.S. units of measure are shown with their respective metric equivalents throughout this technical manual. These equivalents are the SI (International System) Units of Measure.

**<https://www.ebooklibonline.com>**

Hello dear friend!

Thank you very much for reading.

Enter the link into your browser.

The full manual is available for immediate download.

**<https://www.ebooklibonline.com>**

## SAFETY AND YOU



T27999N

### INTRODUCTION

 This safety alert symbol identifies important safety messages in this manual and on the mower-conditioner. When you see this symbol, be alert to the possibility of personal injury and carefully read the message that follows.

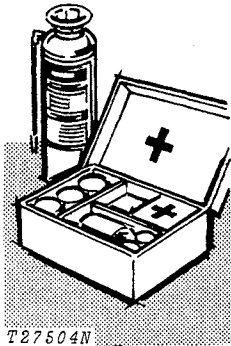

T27504N

Be prepared if an accident or fire should occur. Know where the first aid kit and the fire extinguishers are located in your area—know how to use them.

### SERVICE AREA

Keep the service area clean and dry. Wet or oil floors are slippery. Wet spots can be dangerous when working with electrical equipment.

Make sure the service area is adequately vented.

Periodically check the stop exhaust system for leakage. Engine exhaust gas is dangerous.

Be sure all electrical outlets and tools are properly grounded.

Use adequate light for the job at hand.

### AVOID FIRE HAZARDS

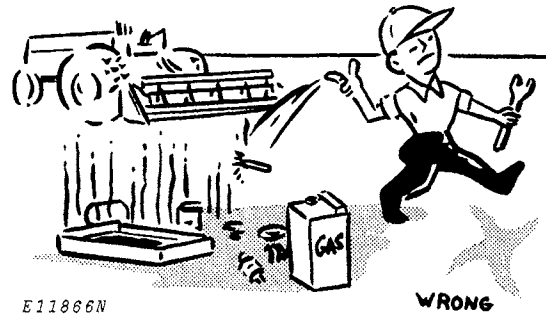

E11866N

WRONG

Don't smoke while refueling or handling highly flammable material.

Engine should be shut off when refueling.

Use care in refueling if the engine is hot.

Don't use open pans of gasoline or diesel fuel for cleaning parts. Good commercial, nonflammable solvents are preferred.

Don't allow sparks or open flame near batteries.

Don't smoke near a battery.

Never check fuel, battery electrolyte or coolant levels with an open flame.

Never use an open flame as a light anywhere on or around the equipment.

## CLEANING THE MOWER-CONDITIONER

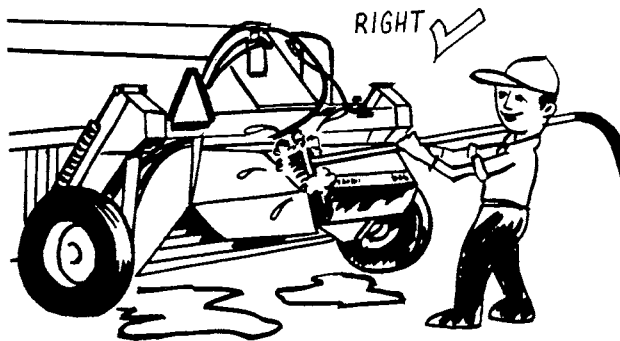

E15641

Always stop the tractor engine before cleaning the mower-conditioner.

### FLUIDS UNDER PRESSURE

Escaping fluid under pressure can have sufficient force to penetrate the skin, causing serious personal injury. Before disconnecting lines, be sure to relieve all pressure. Before applying pressure to the system, be sure all connections are tight and that lines, pipes and hoses are not damaged. Fluid escaping from a very small hole can be almost invisible. Use a piece of cardboard or wood, rather than hands, to search for suspected leaks.

If injured by escaping fluid, see a doctor at once. Serious infection or reaction can develop if proper medical treatment is not administered immediately.

Don't forget the hydraulic system may be pressurized! To relieve pressure, follow the instructions in this technical manual.

When checking hydraulic pressure, be sure to use the correct test gauge for the pressure in the particular system.

## PERSONAL SAFETY

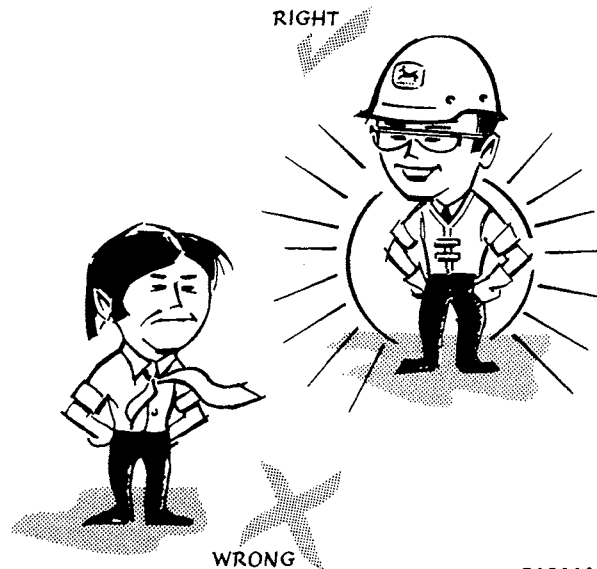

T27502N

Always avoid loose clothing or any accessory—**FLOPPING CUFFS, DANGLING NECKTIES AND SCARVES**—that can catch in moving parts and put you out of work. Always wear your safety glasses while on the job.

Before removing any shielding, stop tractor engine. Take all objects from your pockets which could fall. Don't let adjusting wrenches fall into opened areas.

Don't attempt to check belt tension while the tractor engine is running.

Avoid working on equipment with the tractor engine running. If it is necessary to make checks with the engine running, **ALWAYS USE TWO PEOPLE**—one, the operator, at the controls, the other checking the machine, always in view of the operator. Also, place the transmission in neutral, set the brake, and apply any safety locks provided. **KEEP HANDS AWAY FROM MOVING PARTS.**

Use extreme caution when raising the platform or testing the mower-conditioner.

# Section 10 GENERAL

## CONTENTS OF THIS SECTION

	Page		Page
<b>GROUP 5 - SPECIFICATIONS</b>		<b>GROUP 20 - LUBRICATION</b>	
Specifications .....	5-1	General Information .....	20-1
Torque Value Chart .....	5-3	Greases .....	20-1
<b>GROUP 10 - DIAGNOSING MALFUNCTIONS</b>		Hydraulic Oil .....	20-1
Diagnosing Malfunctions .....	10-1	Storing Lubricants .....	20-1
<b>GROUP 15 - DESCRIPTION</b>			
General Information .....	15-1		

## Group 5 SPECIFICATIONS

**Conditioner Rolls:**

Drive .....	Timed Roller Chain
Construction .....	Formed steel, fluted
Diameter .....	7-3/4 in. (197 mm)
Length .....	58 in. (1 473 mm)
Speed .....	811 rpm

**Cutterbar:**

Guards .....	Heavy-duty, double forged steel
Guard angle .....	6, 9, or 12° downward
Knives (chrome) .....	Overserrated, underserrated or smooth
Speed .....	1650 strokes per min.
Type drive .....	Enclosed, running in oil

**Cutting Height** ..... -2 in. to 19 in. (-51 to 483 mm)

**Operating Speed** ..... Up to 6 mph (9.7 km/h)

**Power Take-off Speed** ..... 540 rpm

**Reel:**

Diameter .....	42 in. (1 067 mm)
Drive .....	V-belt
Speed:	
Standard .....	50-80 rpm
Tooth bars .....	4, 5, or 6 bat cam controlled tooth angle

**Tractor Hydraulic Pressure to Lift Platform** ..... 1750 psi (121 bar) (123 kg/cm<sup>2</sup>)

**Wheels:**

Tire size .....	11L x 4
Tire inflation pressure .....	32 psi (2 bar) (2 kg/cm <sup>2</sup> )
Gauge wheels (optional) .....	28 psi (2 bar) (2 kg/cm <sup>2</sup> )

# SPECIFICATIONS—Continued

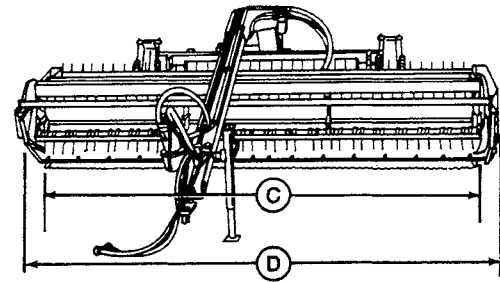
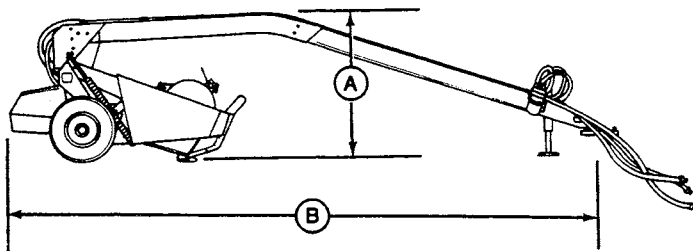

E15636

E15637

A—Height ..... 5 ft. 3 in. (1 600 mm)  
 B—Length ..... 21 ft. 9 in. (6 629 mm)

C—Operating Width:  
 12 ft. (3 658 mm) platform ..... 18 ft. 9 in. (5 715 mm)  
 14 ft. (4 267 mm) platform ..... 20 ft. 9 in. (6 235 mm)  
 D—Transporting Width:  
 12 ft. (3 658 mm) platform ..... 13 ft. (3 962 mm)  
 14 ft. (4 267 mm) platform ..... 15 ft. (4 572 mm)

Fig. 1—Dimensions of 1380 Mower-Conditioner

### Weight:

With 12 ft. (3 658 mm) platform ..... 4397 lbs. (1979 kg)  
 With 14 ft. (4 267 mm) platform ..... 4487 lbs. (2019 kg)

### Speed (No load):

Auger  
 13 Tooth ..... 173 rpm  
 15 Tooth ..... 200 rpm  
 Knife ..... 1650 cuts per minute

### Width of cut:

12 ft. (3 658 mm) platform ..... 12 ft. 3 in. (3 734 mm)  
 14 ft. (4 267 mm) platform ..... 14 ft. 3 in. (4 343 mm)

### HYDRAULICS

Item	Measurement	Specification
<b>Steering Cylinder</b>	Bore	3.00 in. (76 mm)
	Stroke	16.00 in. (406 mm)
	Maximum Pressure	2500 psi (172 bar) (175 kg/cm <sup>2</sup> )
<b>Master Cylinder</b>	Bore	2.25 in. (57 mm)
	Stroke	12.50 in. (318 mm)
	Maximum Pressure	2250 psi (155 bar) (158 kg/cm <sup>2</sup> )
<b>Slave Cylinder</b>	Bore	1.88 in. (48 mm)
	Stroke	12.50 in. (318 mm)
	Maximum Pressure	2250 psi (155 bar) (158 kg/cm <sup>2</sup> )

Item	Measurement	Specification
<b>Filter</b>	10 Micron, Full Flow with Bypass	200 psi (14 bar) (14 kg/cm <sup>2</sup> ) Max.
<b>Reservoir</b>	Capacity	13 U.S. Gallons (49 L)
	Operating Fluid Temperature	160°F (71°C)
	Maximum Fluid Temperature	200°F (93°C)
<b>Relief Valve</b>	Relief Pressure	3500 psi (241 bar) (246 kg/cm <sup>2</sup> )
<b>Pump Unit</b>	Displacement	2.77 cu. in. (45.4 cm <sup>3</sup> )
	Output Flow	23.4 gpm (88.6 L/pm) Min.
	Shaft Speed	2160 rpm
	Gear Case Ratio	4:1 Step up
	Case Drain Flow	4.2 gpm (15.9 L/pm) Max.
	Case Drain Pressure	30 psi (2 bar) (2 kg/cm <sup>2</sup> ) Maximum
<b>Motor</b>	Displacement	5.04 cu. in. (82.6 cm <sup>3</sup> )
	No-Load Shaft Speed	1176 rpm
	Case Drain Flow	1.8 gpm (6.8 Lpm) Maximum
	Case Drain Pressure (Must not exceed motor outlet pressure)	100 psi (7 bar) (7 kg/cm <sup>2</sup> ) Maximum

**TORQUE CHART AND VALUES**

RECOMMENDED TORQUE IN FT-LBS (Nm) COARSE AND FINE THREADS			
Bolt Diameter	Plain Head	Three Dashes	Six Dashes
1/4	Not used	10 (14)	14 (19)
5/16	Not used	20 (27)	30 (41)
3/8	Not used	35 (47)	50 (68)
7/16	35 (47)	55 (75)	80 (108)
1/2	55 (75)	85 (115)	120 (163)
9/16	75 (102)	130 (176)	175 (237)
5/8	105 (142)	170 (230)	240 (325)
3/4	185 (251)	300 (407)	425 (576)
7/8	160 (217)	445 (603)	585 (929)
1	250 (339)	670 (908)	1030 (1397)
1-1/8	330 (447)	910 (1234)	1460 (1980)
1-1/4	480 (651)	1250 (1695)	2060 (2793)

The types of bolts and cap screws are identified by head markings as follows:

Plain Head: regular machine bolts and cap screws.

3-Dash Head: tempered steel high-strength bolts and cap screws.

6-Dash Head: tempered steel extra high-strength bolts and cap screws.

Machine bolts and cap screws 7/8-inch and larger are sometimes formed hot rather than cold, which accounts for the lower torque.

### TORQUE CHART AND VALUES—Continued

Location	Torque (ft-lbs)	(Nm)	(kgm)
Planetary Gear Case Front Plate Bolts	15-18	20-24	2-2.4
Planetary Gear Case Mounting Bolts	55-60	75-81	7.5-8.1
Motor Backplate Mounting Bolts	15-18	20-24	2-2.4
Steering Cylinder Piston Rod Lock Nut	150-170	205-232	20.5-23.2
Cutterbar Drive Case Cover Bolts	150	203	20.3
Cutterbar Drive Case Flywheel Nut	200	271	27.1
Drive Arm Holder Nut	160 (then rap with hammer to one more castellation)	217	21.7

### SPECIAL TOOLS

No.	Name	Use
JDO-1*	Puller	Remove cutterbar drive arm.
TY5011	Riveting Tool	Installing knife sections.
D-15017 NU*	Hydraulic Flow Meter	Check hydraulic flow and pressure.
D-1074AA*	Hydraulic Flow Meter	Check hydraulic flow and pressure.
D-15027NU*	Universal Pressure Test Kit	To check hydraulic pressures.
D-15016NU*	Fitting Kit	To connect the hydra-analyzer or pressure gauge into the hydraulic system.

\*Order from Owatonna Tool Company, Owatonna, Minnesota 55060.

## Group 10

# DIAGNOSING MALFUNCTIONS

The majority of operating problems that occur with the mower-conditioner can sometimes be traced to improper adjustment or delayed service. The following malfunctions are designed to help you when a problem develops by suggesting a problem, cause, and the recommended solution.

These suggested malfunctions should be applied with caution. Make certain the source of the problem is not located someplace other than where the problem exists. A thorough understanding of the mower-conditioner is a must if operating problems are to be corrected satisfactorily.

### ORGANIZING THE DIAGNOSIS

#### 1. Know the Unit.

Study this manual to know how the individual components work and their function in the over-all system.

Keep up with the latest service information. Read it and store it in a handy reference file.

#### 2. Consult the Operator.

Ask the operator how the unit was performing when the problem occurred. Find out if any corrective measures were already taken. Ask if the unit was serviced regularly as prescribed in the operator's manual.

#### 3. Operate the Unit.

If the unit can be safely operated, see for yourself how it malfunctions—don't completely rely on the operator's diagnosis.

#### 4. Inspect the Unit.

Visually check the unit. Look at the components for any cracked welds, loose hardware, damaged linkages, worn or broken lines, or anything that looks out of the ordinary.

#### 5. List the Probable Causes.

Write down the information you have learned by steps 1 through 4. What are the signs you found while inspecting the unit and what are the most probable causes as outlined under "Diagnosing"?

#### 6. Reach Some Conclusions.

Look over the possible causes and decide which ones are the most likely. Reach your decision on the most probable cause and plan to check it first.

#### 7. Test Your Conclusions.

Before disassembling any components, test your conclusions to see which are correct. Tests narrow the possibilities and soon the actual cause will be pinpointed.

### DIAGNOSING

#### Excessive Noise

Conditioner Noise.

Rolls too close.

Space Rolls. See page 20-20-7.

Rolls out of time.

Retime rolls. See page 20-20-8.

#### Cutterbar Noise.

Knife or guards bent.

Straighten knife and reset guards.

Loose knife drive case.

Tighten four mounting bolts. See page 40-5-8.

Loosen or worn knife head pin.

Check bushing. Tighten or replace pin. See page 40-10-6.

Loosen knife drive arm.

Tighten nut securing arm to knife drive case. See page 40-5-8.

#### Pump Noise

Low hydraulic fluid.

Check and add fluid as necessary to maintain 13 gal. (U.S.) (49.2 L) level. See page 10-20-1.

Restricted suction line.

Check pump inlet and suction hose for kink or plug and air leaking into system.

Hydraulic fluid too thick, cold weather.

Check for correct hydraulic fluid. See page 10-20-1.

Run machine with no load until fluid warms up.

**DIAGNOSING—Continued****Poor Cutting**

Ragged and Uneven Cutting of Crop.

Various parts of cutterbar, such as knife sections, guards, wear plates, etc., are worn, damaged, or broken.

Check and replace all worn and broken parts on cutterbar to obtain an even cutting of crop. See page 40-15-1.

Bent knife, causing binding of cutting parts.

Straighten a bent knife. Check guard alignment and align if necessary for a smooth cut.

Hold-downs worn or not adjusted to allow knife to work freely.

Adjust or align hold-downs so knife will work freely, but still keep knife sections from lifting off guards. See page 40-10-2 or 40-10-5.

Looseness between knife back and guard.

Adjust hold-downs so knife back is snug to guard. See page 40-10-2 or 40-10-5.

Ground speed too fast.

Slow down.

Lips of guard out of adjustment or bent, causing poor shearing action.

Adjust lip of guard so it is parallel to shear edge of guard. See page 40-10-2.

Loose knife drive belt.

Adjust belt tension. See page 40-5-8.

Improper platform float spring adjustment.

Readjust float springs. See operator's manual.

**Knife Plugging.**

Loose knife drive belt.

Adjust belt tension. See page 40-5-8.

Dull or broken knife sections.

Resharpener or replace, as required. See page 40-15-1.

Bent or broken guard.

Replace.

Improper platform float spring adjustment.

Readjust float springs. See operator's manual.

Improper hold-down adjustment.

Readjust hold-downs. See page 40-10-2 or 40-10-5.

Improper reel adjustment.

Adjust reel and cam. See page 20-10-11.

**Knife Gumming**

Juice buildup due to cutting operation.

Use smooth knife sections.

Periodically clean knife with water.

**Mud and Dirt Buildup on Platform.**

Cutterbar too low.

Raise cutterbar using gauge shoes.

Raise cutterbar by reducing guard angle.

**Crop Loss at Cutterbar**

Leaf loss or crop damage.

Reel speed not coordinated with ground speed, causing excessive agitation before crop is cut.

Change reel drive to coordinate reel speed with ground speed so reel will move material smoothly and evenly. Reel speed should be slightly faster than ground speed. See operator's manual.

Ground speed too fast for condition of crop.

Slow down.

Crop carrying over top of reel.

Reduce reel speed. See operator's manual.

Rotate cam for earlier release. See page 20-10-11.

**Excessive Breakage of Knife Sections or Guards.**

Cutterbar operating too low in stony field conditions.

Raise cutterbar, using gauge shoes.

Raise cutterbar by reducing guard angle.

Improper platform float spring adjustment.

Readjust float springs. See operator's manual.

Bent or broken guard.

Replace.

Improper hold-down adjustment.

Readjust hold-downs. See page 40-10-2 or 40-10-5.

Ground speed too fast.

Slow down.

Reel teeth too low (teeth into knife).

Raise reel and replace damaged parts. See page 20-10-11.

**Knife Back Breakage.**

Worn wear plates.

Replace. See page 40-10-2 or 40-10-5.

Bent or broken guard.

Replace. See page 40-10-2 or 40-10-5.

Dull knife.

Sharpen or replace. See page 40-15-1.

**Leaving Long or Uneven Stubble.**

- Ground speed too fast.
  - Slow down.
- Slow PTO speed.
  - Maintain 540 rpm.
- Gauge shoes set too high.
  - Lower gauge shoes.
- Guard angle too flat.
  - Increased guard angle.

**Strips of Uncut Material.**

- Crowding uncut crop.
  - Allow enough room for crop to be fed to cutterbar.
- Foreign objects on cutterbar.
  - Disengage tractor PTO and stop engine. After all moving parts are completely stopped, remove foreign objects.
- Broken knife sections.
  - Replace as required. See page 40-15-1.

**Reel Problems.**

- Crop carrying over top of reel.
  - Wrong cam angle.
    - Rotate cam for early release. See page 20-10-11.
  - Reel speed too fast.
    - Reduce reel speed. See operator's manual.
- Down crop left uncut.
  - Incorrect location of reel.
    - Place reel well ahead and down. See page 20-10-11.
  - Ground speed too fast.
    - Slow down.
  - Very heavy crop.
    - Cut less than full width of crop.
- Reel hesitation.
  - Low hydraulic fluid.
    - Check and add fluid.
  - Inadequate belt tension.
    - Tighten drive belt. See page 20-15-8.
  - Too many bats.
    - Use 4 bats maximum.
  - Cam rollers leave cam track.
    - Loose bat clamps.
      - Realign for 1/8-inch (3.2 mm) clearance between roller arm and cam track and tighten bat clamp bolts. See page 20-10-12.
    - Roller not in cam far enough.
      - Reshim for 1/8-inch (3.2 mm) clearance between roller arm and cam track. See page 20-10-12.

**Stems Shredding.**

- Improper roll spacing.
  - Increase roll spacing. See page 20-20-9.

**Rolls Plugging.**

- Foreign objects between rolls.
  - Disengage tractor PTO and stop engine. When all moving parts are completely stopped, remove foreign objects.
- Roll pressure too tight.
  - Reduce spring tension. See page 20-20-7.
- Very heavy crop.
  - Cut less than full width of cutterbar.

**Auger Problems.**

- Crop carries over top of auger.
  - Incorrect stripper adjustment.
    - Readjust for 1/8-inch (3.2 mm) clearance between strippers and auger. See page 20-15-7.
- Crop warps around middle of auger (may plug).
  - Heavy long-stem crop.
    - Remove rubber auger paddles.

**Poorly Formed Windrows.**

- Reel cam set for late release.
  - Adjust cam. See page 20-10-11.
- Incorrect auger speed.
  - Change auger drive sprocket. See operator's manual.
- Ground speed too slow.
  - Increase ground speed to crowd crop into machine.
- Incorrect swath board position.
  - Move board up or down as needed.
- Too much gap between auger and stripper.
  - Readjust to 1/8-inch (3.2 mm) maximum gap. See page 20-15-7.

**Platform Swings Too Far (Or Not Far Enough).**

- Incorrect swing cylinder adjustment.
  - Adjust to 26-1/4 inches (667) between pin centers when retracted. See page 30-25-3.

**Platform Drafts At Angle.**

- Incorrect float spring adjustment.
  - Readjust float spring. See operator's manual.

**DIAGNOSING—Continued****Platform Swings Too Fast (Or Too Slow)**

Incorrect tractor hydraulic outlet throttle control.  
Readjust.

**Platform Raises Too Fast (Or Too Slow)**

Incorrect tractor hydraulic outlet throttle control.  
Readjust.

**Platform Will Not Swing or Platform Will Not Raise**

Inadequate hydraulic pressure from tractor.  
Check pressure.

**Motor Turns While Unloaded But Slows Down or Stops When Load is Applied**

Scored back plate.  
Remove back plate and examine surface condition of flat area, if scored, replace back plate.  
Scored connector plate.  
Scored or worn piston shoes.  
Low relief valve pressure.  
Do not lap. See page 30-15-2.  
Disassemble motor, check finish on connector plate and back plate, replace if necessary. See page 30-15-2.  
Disassemble motor, examine condition of shoes on pistons, replace pistons as a complete set if necessary. See page 30-15-2.  
Check relief valve for proper pressure setting, replace relief valve cartridge if necessary. See 30-20-2.

**Hydraulic Motor Will Not Turn**

Severely scored back plate and connector plate.  
Contaminate particle holding connector off back plate.  
Disassemble motor completely.  
Inspect all parts, clean all parts, replace all worn parts and flush hydraulic system.  
Disassemble motor, inspect and clean parts, replace necessary parts. See page 30-15-2.

**Oil Heating**

Oil supply low.  
Contaminated oil.  
Setting of relief valve too high or too low.  
Oil in system too light.  
Dirty filter.  
Fill reservoir. See page 10-20-1.  
Drain reservoir and refill with clean oil. See page 10-20-1.  
Replace valve cartridge. See 30-20-2.  
Drain reservoir and refill with proper viscosity oil. See page 10-20-1.  
Replace filter. See operator's manual.

**Shaft Seal Leakage**

Worn shaft seal.  
Excessive internal wear.  
Replace shaft seal. See page 30-10-5 or 30-15-4.  
Disassemble unit and inspect.

**Foaming Oil**

Low oil level.  
Air leaking into suction line.  
Wrong kind of oil.  
Fill reservoir. See page 10-20-1.  
Tighten fittings.  
Drain and fill reservoir with non-foaming oil. See page 10-20-1.

# Group 15 DESCRIPTION

## GENERAL INFORMATION

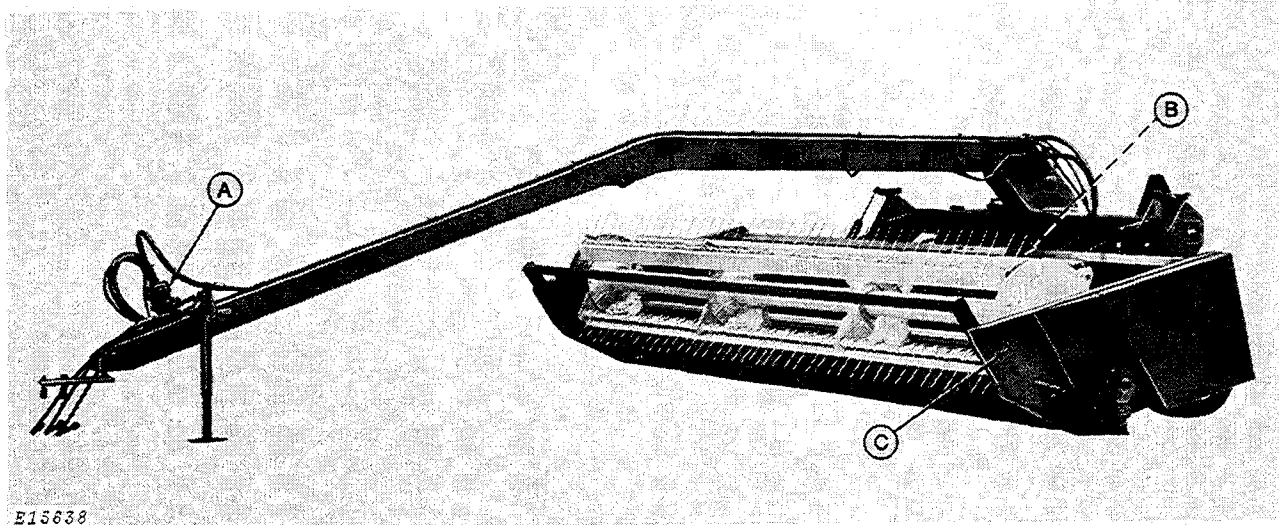

A—Hydraulic Pump

B—Hydraulic Motor

C—Platform

Fig. 1-Overall View

The 1380 Mower-Conditioner is driven by a pump (A, Fig. 1) attached to the tractor PTO shaft. The pump in turn drives the hydraulic motor (B), which is attached to the cutting platform (C).

The platform can be hydraulically positioned behind the tractor for transport. This allows maneuvering the platform around trees, through gates and placing the platform into transport and operating positions.

When servicing the mower-conditioner, pay particular attention to the tractor-mower-conditioner hookup geometry, Fig. 2.

If the hitch extension (E, Fig. 2) isn't used, the following problems could occur:

1. Premature failure of the hydraulic components.
2. Damage to the hydraulic hoses.
3. The turning radius is increased.

The proper hitch extension hookup is illustrated in Fig. 2.

### SERIAL NUMBER

The serial number for the platform is located on the upper rear portion of the frame on the left-hand side.

The serial number for the conditioner is located in the upper left-hand corner of the frame.

The serial number for the tongue and frame is on the left-hand side of the frame.

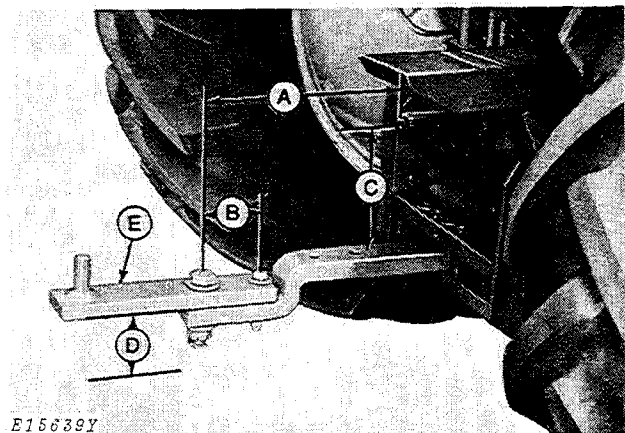

A—14 Inches (356 mm)

B—4 Inches (102 mm)

C—6 to 12 Inches (152 to 305 mm)

D—13 to 17 Inches (330 to 432 mm)

E—Hitch Extension

Fig. 2-Hookup Dimensions

### Tractor Requirements

The tractor must have two hydraulic outlets; one for the two hoses which pivot the carrier frame and one for the single hose to lift the platform.

The tractor must have a 540 rpm PTO and have a minimum of 70 horsepower (52 kW).



# Group 20 LUBRICATION

Carefully written and illustrated lubrication instructions are included in the operator's manual furnished with your customer's machine. Remind the customer to follow these instructions.

For your convenience, the following chart shows capacities and types of lubricants for the mower-conditioner. Specifications for lubricants follow the chart.

Component	Capacity	Type of Lubricant	Interval of Service
<b>Roller Chains</b>	.....	John Deere PT 508 Special Lubricant or SAE 30 engine oil	Daily
<b>Cutterbar Drive Case</b>	2-1/2 to 3-1/2 in. (64 to 89 mm) below fill plug	SAE 85-140 API-GL5 Gear Lubricant	Each Season
<b>Tongue</b>	13 gal. (49 L)	John Deere All-Weather Hydrostatic Fluid or Texaco Type F Automatic Transmission Fluid	Each Season

## GREASES

John Deere Multi-Purpose Lubricant or an equivalent SAE multipurpose-type grease is recommended for all grease fittings. Application of grease as instructed in the lubrication chart will provide proper lubrication and will prevent contamination of bearings.

## STORING LUBRICANTS

The mower-conditioner can operate efficiently only if clean lubricants are used. Use clean containers to handle all lubricants. Store them in an area protected from dust, moisture, and other contaminants.

## CHECKING FLUID LEVEL

Periodically check the fluid level in the hydraulic reservoir (A, Fig. 1) with the dipstick (B). The mower-conditioner should be attached to the tractor when checking the fluid level. If the reservoir has been drained, refill by adding 13 U.S. gals. (49 L) of John Deere All Weather Hydrostatic Fluid. Operate the pump for 2 minutes, recheck the fluid level and fill as needed.

*NOTE: John Deere Hy-GARD Transmission and Hydraulic Oil may be added to or mixed with John Deere All Weather Hydrostatic fluid.*

**IMPORTANT: Keep fluid clean, free of dust, water, and sealing compound. DO NOT add brake fluid.**

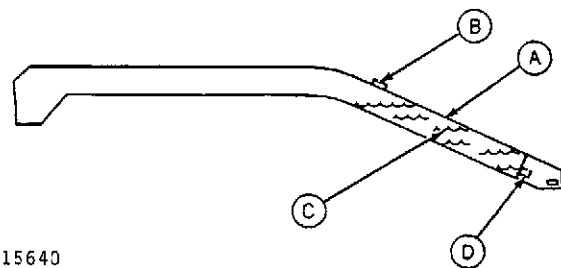

E15640

- A—Reservoir
- B—Dipstick & Fill Port
- C—Fluid
- D—Drain Plug

Fig. 1-Checking Fluid Level

# SECTION 20 PLATFORM

## CONTENTS OF THIS SECTION

	Page		Page
GROUP 5 - GENERAL INFORMATION AND REMOVAL		GROUP 20 - CONDITIONER	
Platform and Hay Conditioner Drive .....	5-2	General Information .....	20-1
Removal .....	5-3	Conditioner Removal .....	20-2
GROUP 10 - REEL		Assembly .....	20-3
General Information .....	10-1	Conditioner Drives .....	20-4
Reel Removal .....	10-2	Adjustments .....	20-7
Replacing Reel Teeth .....	10-5	Roll Pressure .....	20-7
Cam Follower Bearing .....	10-8	Conditioner Drive Chain .....	20-7
Multi-Bat Reel Conversion .....	10-8	Lower Roll Drive Chain .....	20-8
6-Bat Reel .....	10-9	Upper Roll Drive Chain .....	20-8
Adjustments .....	10-11	Roll Timing .....	20-8
Reel Cam .....	10-11	Roll Spacing .....	20-9
Reel Horizontally and Vertically .....	10-11	GROUP 25 - RIGHT-HAND AND LEFT-HAND CROSS SHAFT	
Cam Followers .....	10-12	General Information .....	25-1
GROUP 15 - AUGER		Right-Hand Cross Shaft .....	25-2
Right-Hand Auger Shaft Removal .....	15-1	Removal .....	25-2
Left-Hand Auger Shaft Removal .....	15-4	Assembly .....	25-3
Auger Removal .....	15-5	Left-Hand Cross Shaft .....	25-5
Adjustments .....	15-8	Removal .....	25-5
Knife Drive Belt .....	15-8	Assembly .....	25-6
Auger Drive Chain .....	15-8		
Reel Drive Belt .....	15-8		

## Group 5 GENERAL INFORMATION AND REMOVAL

### PLATFORM AND HAY CONDITIONER DRIVE

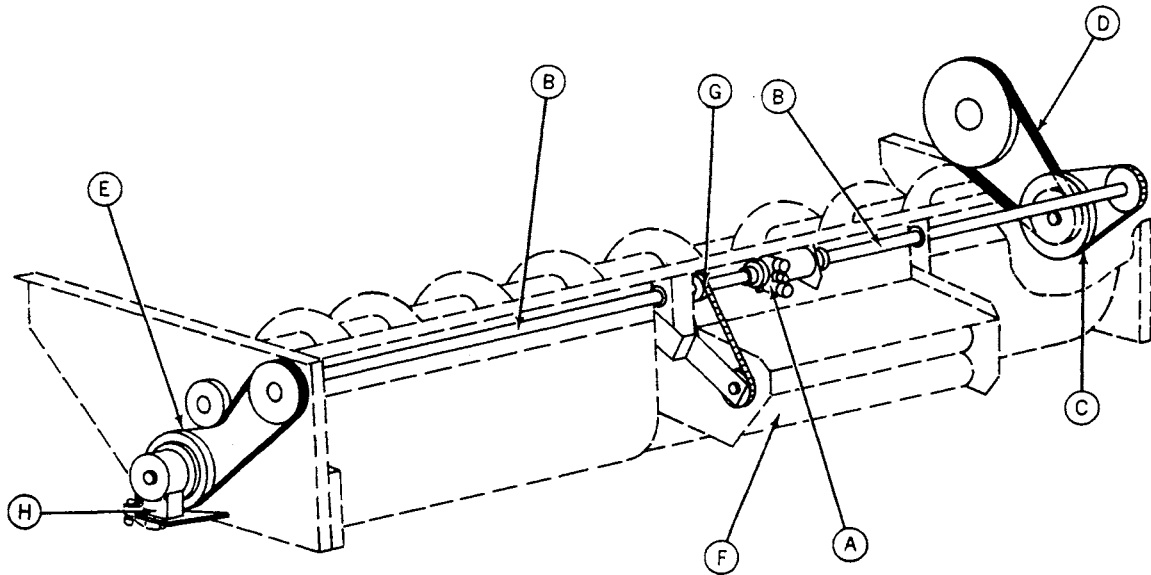

E15648

A—Hydraulic Motor  
B—Cross Shafts

C—Auger Drive Chain  
D—Reel Drive Belt

E—Knife Drive Case Belt  
F—Conditioner

G—Conditioner Drive Chain  
H—Knife Drive Case

Fig. 1-Platform and Hay Conditioner Drives

Power to the platform (Fig. 1) is transmitted by the hydraulic motor (A) to right-hand and left-hand platform ends with two cross drive shafts (B).

The right-hand cross shaft drives the auger with a drive chain (C). A variable sheave attached to the auger shaft drives the reel with a V-belt (D). The drive belt is under constant tension from a spring-loaded idler.

The left-hand cross shaft (B), drives the knife drive case (H) with a V-belt (E) and conditioner (F) with a drive chain (G). The knife drive case (H) is driven directly from this sheave with a single V-belt. Belt tension is applied by an idler.



**Suggest:**

**If the above button click is invalid.**

**Please download this document**

**first, and then click the above link**

**to download the complete manual.**

**Thank you so much for reading**

## REMOVAL

Move machine to a level area.

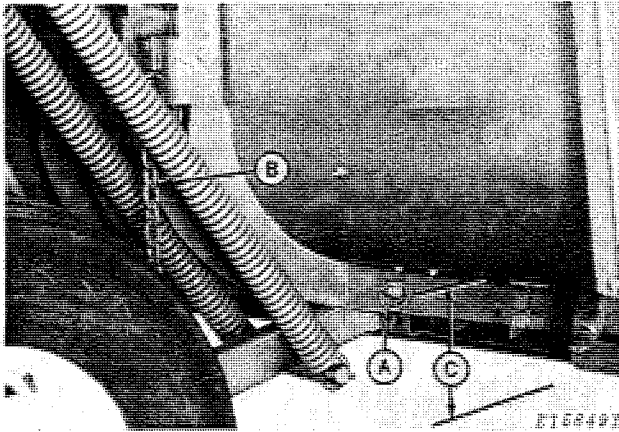

A—Quik-Lock Pin  
B—Safety Chain

C—14-inch (356 mm)

Fig. 2-Detaching Lower Lift Arm

Remove Quik-Lock pin (A, Fig. 2) and lift arm pin.  
Remove safety chain (B).

Repeat on opposite side.

Raise platform approximately 14-inches (356 mm) from ground to lower lift pin hole (C). Block securely.

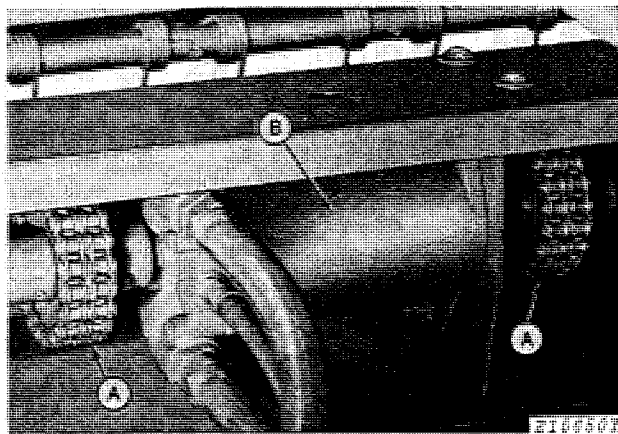

A—Coupler Chain

B—Hydraulic Motor

Fig. 3-Removing Hydraulic Motor

Remove two 1/2 x 1-1/4-inch carriage bolts, two 1/2 x 1-1/4-inch cap screws and lock nuts.

Remove two 5/16 x 3/4 cap screws from rear motor mount bracket.

Remove both coupler chains (A, Fig. 3)

Remove hydraulic motor (B) with hydraulic lines still attached and wire motor to side of tongue.

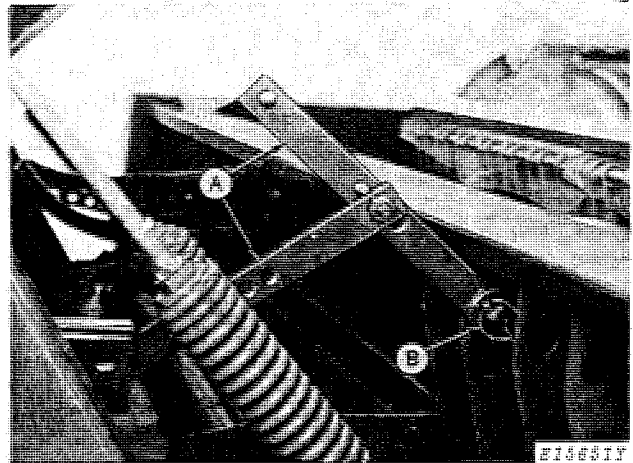

A—Upper Link

B—Quik-Lock Pin

Fig. 4-Removing Upper Link

Remove 5/8 x 1-3/4-inch cap screw and lock nut in rear of upper link (A, Fig. 4).

Remove Quik-Lock pin (B) and upper link.

Repeat on opposite side.

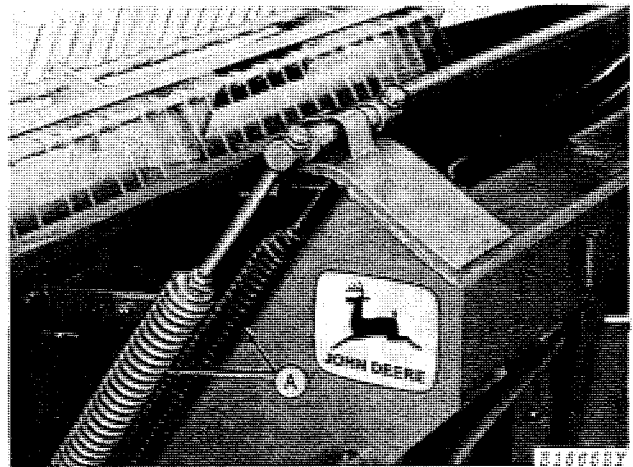

A—Float Springs

Fig. 5-Loosening Float Springs

Remove tension from float springs (A, Fig. 5) until lower lift arm has lowered out of way sufficiently.

Repeat on opposite side.

Main frame and tongue can now be moved away from platform.

**NOTE:** See page 30-15-7 when difficulties result in misalignment of hydraulic motor.

**<https://www.ebooklibonline.com>**

Hello dear friend!

Thank you very much for reading.

Enter the link into your browser.

The full manual is available for immediate download.

**<https://www.ebooklibonline.com>**