

924DE, 1128DE, 1128DDE, and 1332DDE Walk-Behind Snowblowers

TECHNICAL MANUAL

**John Deere
Worldwide Commercial and
Consumer Equipment Division**

TM1867 (12Jul00)

Walk-Behind Snowblowers



Model 924DE



Model 1128DE



Model 1128DDE AND 1332DDE

This technical manual is written for an experienced technician and contains sections that are specifically for this product. It is a part of a total product support program.

The manual is organized so that all the information on a particular system is kept together. The order of grouping is as follows:

- Table of Contents
- Specifications
- Component Location
- System Schematic
- Theory of Operation
- Troubleshooting Chart
- Diagnostics
- Tests & Adjustments
- Repair

Note: Depending on the particular section or system being covered, not all of the above groups may be used.

Each section will be identified with a symbol rather than a number. The groups and pages within a section will be consecutively numbered.

We appreciate your input on this manual. To help, there are postage paid post cards included at the back. If you find any errors or want to comment on the layout of the manual please fill out one of the cards and mail it back to us.

All information, illustrations and specifications in this manual are based on the latest information available at the time of publication. The right is reserved to make changes at any time without notice.

COPYRIGHT© 2000
Deere & Co.
John Deere Worldwide Commercial and
Consumer Equipment Division
Horicon, WI
All rights reserved

Safety



Specifications and Information



Engine



Electrical



Power Train



Miscellaneous



<https://www.ebooklibonline.com>

Hello dear friend!

Thank you very much for reading.

Enter the link into your browser.

The full manual is available for immediate download.

<https://www.ebooklibonline.com>



HANDLE FLUIDS SAFELY-AVOID FIRES

- **BE PREPARED FOR EMERGENCIES**

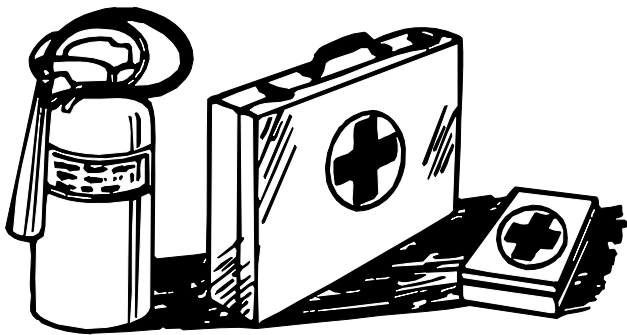

When you work around fuel, do not smoke or work near heaters or other fire hazards.

Store flammable fluids away from fire hazards. Do not incinerate or puncture pressurized containers.

Make sure machine is clean of trash, grease, and debris.

Do not store oily rags; they can ignite and burn spontaneously.

Be prepared if a fire starts.

Keep a first aid kit and fire extinguisher handy.

Keep emergency numbers for doctors, ambulance service, hospital, and fire department near your telephone.

HANDLE CHEMICAL PRODUCTS SAFELY

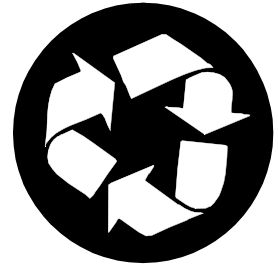
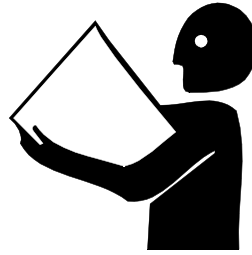

Direct exposure to hazardous chemicals can cause serious injury. Potentially hazardous chemicals used with John Deere equipment include such items as lubricants, coolants, paints, and adhesives.

A Material Safety Data Sheet (MSDS) provides specific details on chemical products: physical and health hazards, safety procedures, and emergency response techniques. Check the MSDS before you start any job using a hazardous chemical. That way you will know exactly what the risks are and how to do the job safely. Then follow procedures and recommended equipment.

- **DISPOSE OF WASTE PROPERLY**

Improperly disposing of waste can threaten the environment and ecology. Potentially harmful waste used with John Deere equipment include such items as oil, fuel, coolant, brake fluid, filters, and batteries. Use leakproof containers when draining fluids. Do not use food or beverage containers that may mislead someone into drinking from them. Do not pour waste onto the ground, down a drain, or into any water source. Inquire on the proper way to recycle or dispose of waste from your local environmental or recycling center, or from your John Deere dealer.

USE SAFE SERVICE PROCEDURES

• WEAR PROTECTIVE CLOTHING

Wear close fitting clothing and safety equipment appropriate to the job.

Prolonged exposure to loud noise can cause impairment or loss of hearing. Wear a suitable hearing protective device such as earmuffs or earplugs to protect against objectionable or uncomfortable loud noises.

Operating equipment safely requires the full attention of the operator. Do not wear radio or music headphones while operating machine.

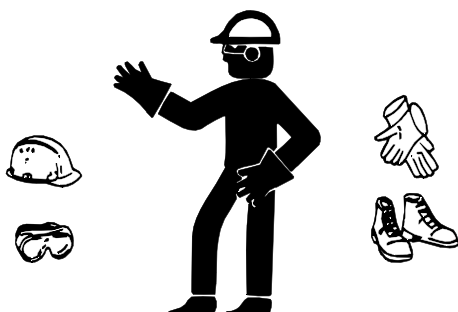

• SERVICE MACHINES SAFELY

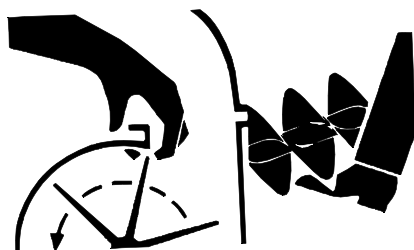

• USE PROPER TOOLS

Use tools appropriate to the work. Makeshift tools and procedures can create safety hazards. Use power tools only to loosen threaded parts and fasteners. For loosening and tightening hardware, use the correct size tools. **DO NOT** use U.S. measurement tools on metric fasteners. Avoid bodily injury caused by slipping wrenches. Use only service parts meeting John Deere specifications.

• PARK MACHINE SAFELY

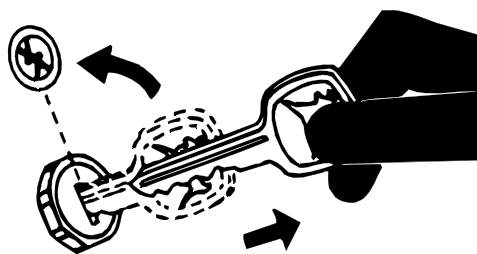

• Before working on the machine:

1. Lower all equipment to the ground.
2. Stop the engine and remove the key.
3. Disconnect the battery ground strap.
4. Hang a "DO NOT OPERATE" tag in operator station.

• SUPPORT MACHINE PROPERLY AND USE PROPER LIFTING EQUIPMENT

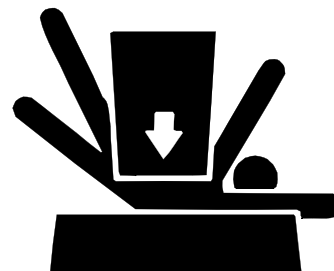

If you must work on a lifted machine or attachment, securely support the machine or attachment.

Do not support the machine on cinder blocks, hollow tiles, or props that may crumble under continuous load. Do not work under a machine that is supported solely by a jack. Follow recommended procedures in this manual.

Lifting heavy components incorrectly can cause severe injury or machine damage. Follow recommended procedure for removal and installation of components in the manual.

• WORK IN CLEAN AREA

• Before starting a job

1. Clean work area and machine.
2. Make sure you have all necessary tools to do your job.
3. Have the right parts on hand.
4. Read all instructions thoroughly; do not attempt shortcuts.





- **ILLUMINATE WORK AREA SAFELY**

Illuminate your work area adequately but safely. Use a portable safety light for working inside or under the machine. Make sure the bulb is enclosed by a wire cage. The hot filament of an accidentally broken bulb can ignite spilled fuel or oil.

- **WORK IN VENTILATED AREA**

WARNING: California Proposition 65

Warning

Diesel engine exhaust and some of its constituents are known to the State of California to cause cancer, birth defects, and other reproductive harm.

Gasoline engine exhaust from this product contains chemicals known to the State of California to cause cancer, birth defects, or other reproductive harm.

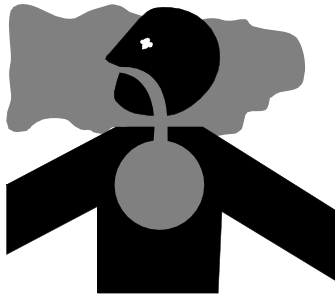

Engine exhaust fumes can cause sickness or death. If it is necessary to run an engine in an enclosed area, remove the exhaust fumes from the area with an exhaust pipe extension.

If you do not have an exhaust pipe extension, open the doors and get outside air into the area.

- **REMOVE PAINT BEFORE WELDING OR HEATING**

Avoid potentially toxic fumes and dust. Hazardous fumes can be generated when paint is heated by welding, soldering, or using a torch. Do all work outside or in a well ventilated area. Dispose of paint and solvent properly. Remove paint before welding or heating: If you sand or grind paint, avoid breathing the dust. Wear an approved respirator. If you use solvent or paint stripper, remove stripper with soap and water before welding. Remove solvent or paint stripper containers and other flammable material from area. Allow fumes to disperse at least 15 minutes before welding or heating.

- **AVOID HARMFUL ASBESTOS DUST**

Avoid breathing dust that may be generated when handling components containing asbestos fibers. Inhaled asbestos fibers may cause lung cancer.

Components in products that may contain asbestos fibers are brake pads, brake band and lining assemblies, clutch plates, and some gaskets. The asbestos used in these components is usually found in a resin or sealed in some way. Normal handling is not hazardous as long as airborne dust containing asbestos is not generated.

Avoid creating dust. Never use compressed air for cleaning. Avoid brushing or grinding material containing asbestos. When servicing, wear an approved respirator. A special vacuum cleaner is recommended to clean asbestos. If not available, apply a mist of oil or water on the material containing asbestos. Keep bystanders away from the area.

- **SERVICE TIRES SAFELY**

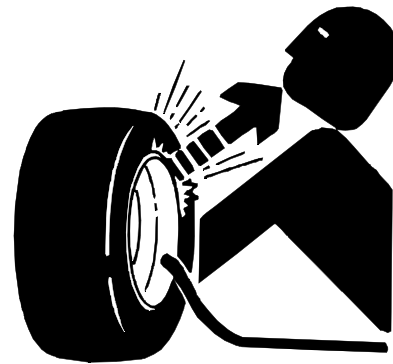

Explosive separation of a tire and rim parts can cause serious injury or death.

Do not attempt to mount a tire unless you have the proper equipment and experience to perform the job. Always maintain the correct tire pressure. Do not inflate the tires above the recommended pressure. Never weld or heat a wheel and tire assembly. The heat can cause an increase in air pressure resulting in a tire explosion. Welding can structurally weaken or deform the wheel.

When inflating tires, use a clip-on chuck and extension hose long enough to allow you to stand to one side and NOT in front of or over the tire assembly. Use a safety cage if available.

- **Check wheels for low pressure, cuts, bubbles, damaged rims or missing lug bolts and nuts.**

AVOID INJURY FROM ROTATING AUGERS

Keep hands and feet away from auger housing. Never try to work on auger or clear any material from auger housing while machine is running or spark plug is connected.

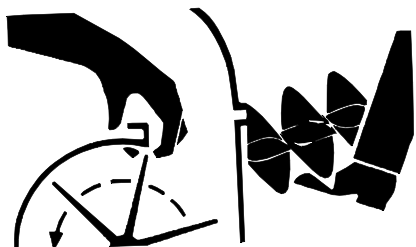

REPLACE SAFETY SIGNS

Replace missing or damaged safety signs. See the machine operator's manual for correct safety sign placement.



LIVE WITH SAFETY



Before returning machine to customer, make sure machine is functioning properly, especially the safety systems. Install all guards and shields.

DIAGNOSTICS

ENGINE WILL NOT CRANK (RECOIL STARTER)

Test Conditions:

- Machine on level surface, key switch “OFF”
- Transmission control in “NEUTRAL”
- Auger drive disengaged
- Friction drive disengaged



Test/Check Point	Normal	If Not Normal
1. Gently pull on starter handle and watch engine output shafts.	Engine output shafts turn over.	Remove recoil starter assembly and check recoil starter for malfunction.
2. Remove recoil starter and install socket and breaker bar on flywheel nut or cap screw and turn clockwise.	Flywheel and output shafts turn over.	Remove flywheel and check key and keyway for damage.
3. With flywheel removed, install flywheel nut or cap screw on or in end of crankshaft and turn clockwise with socket and breaker bar.	Output shafts turn over.	Tear engine down and check for malfunction.

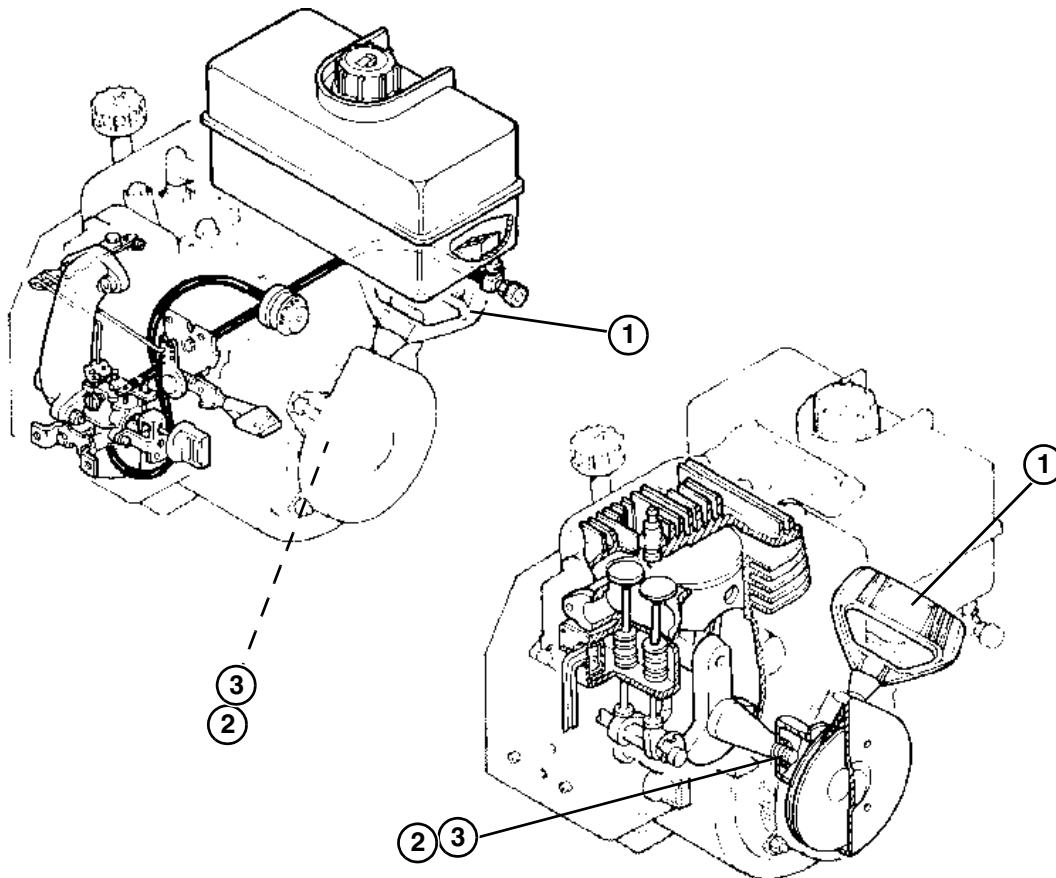

M70862

ENGINE TURNS OVER BUT WILL NOT START

Test Conditions:

- Key switch "OFF"
- Transmission control in "NEUTRAL"
- Auger drive disengaged
- Friction drive disengaged



Test/Check Point	Normal	If Not Normal
1. Spark plug (check for fuel and correct gap)	Plug dry and gap set at 0.76 mm (0.030 in.)	Check carburetor float for engine flooding, clean plug, and set gap.
2. Spark plug (test spark)	Good hot spark	Check ignition circuit. Replace spark plug.
3. Carburetor bowl nut (check for fuel in float bowl. Inspect and clean nut orifice)	Fuel present, bowl clean	Check for lack of fuel in carburetor.
4. Carburetor (check choke adjustment)	Choke plate fully closed with choke control at "Full"	Adjust choke components.

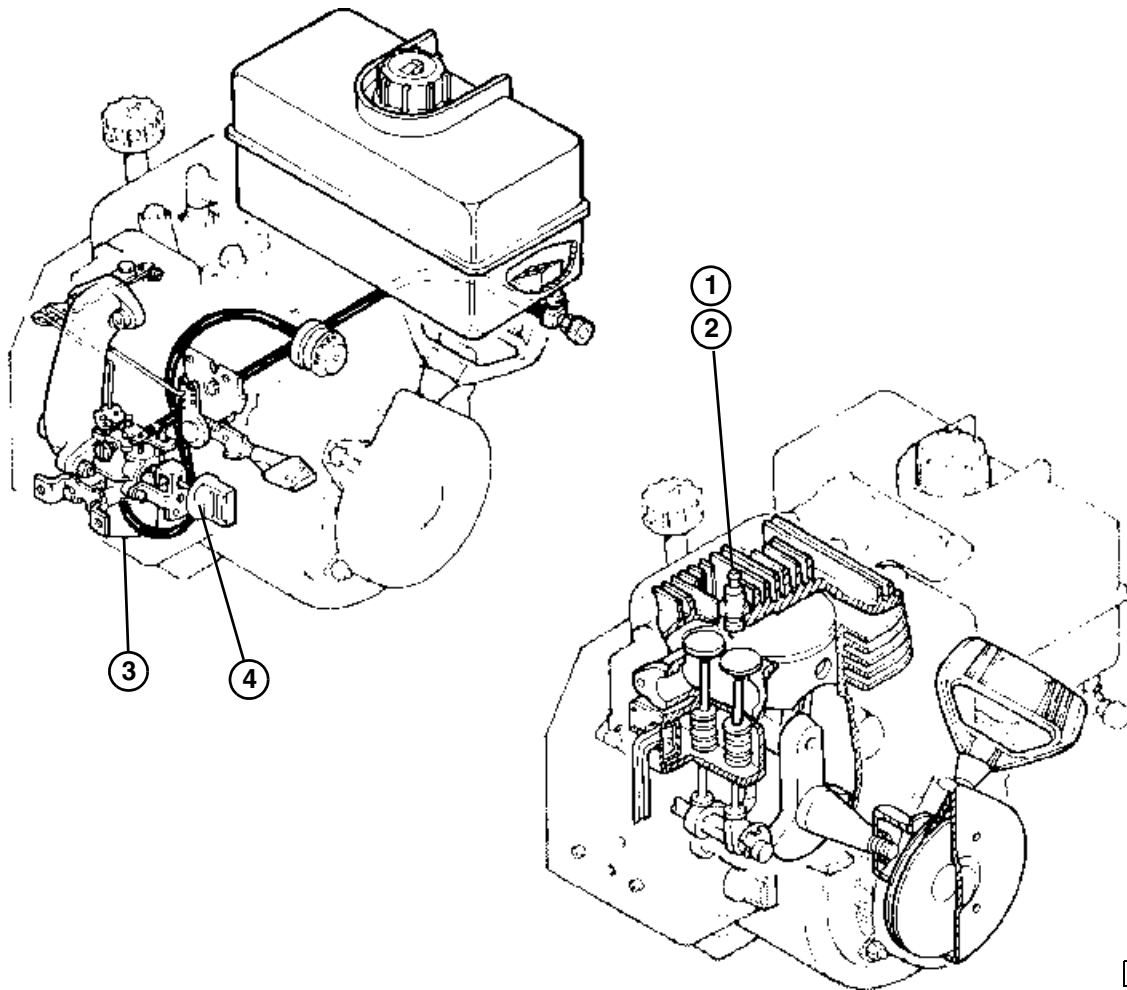

M70862

ENGINE STOPS WHEN HOT

Test Conditions:

- Key switch "OFF"
- Auger drive disengaged
- Transmission control in "NEUTRAL"
- Friction drive disengaged

Test/Check Point	Normal	If Not Normal
1. Spark plug (check for fuel and correct gap)	Plug dry and gap set at 0.76 mm (0.030 in.)	Check carburetor float for engine flooding, clean plug, and set gap.
2. Spark plug (test spark)	Good hot spark	Check ignition circuit. Replace spark plug.
3. Carburetor drain (check for fuel in float bowl)	Fuel present	Check carburetor for lack of fuel.
4. Valves (check clearance)	Intake and exhaust valve clearance is 0.10 mm (0.004 in.)	Adjust valves.
5. Valves (check ACR and valves)	Valves operating	Inspect valve train components.
6. Flywheel (inspect key)	Not sheared	Replace key.

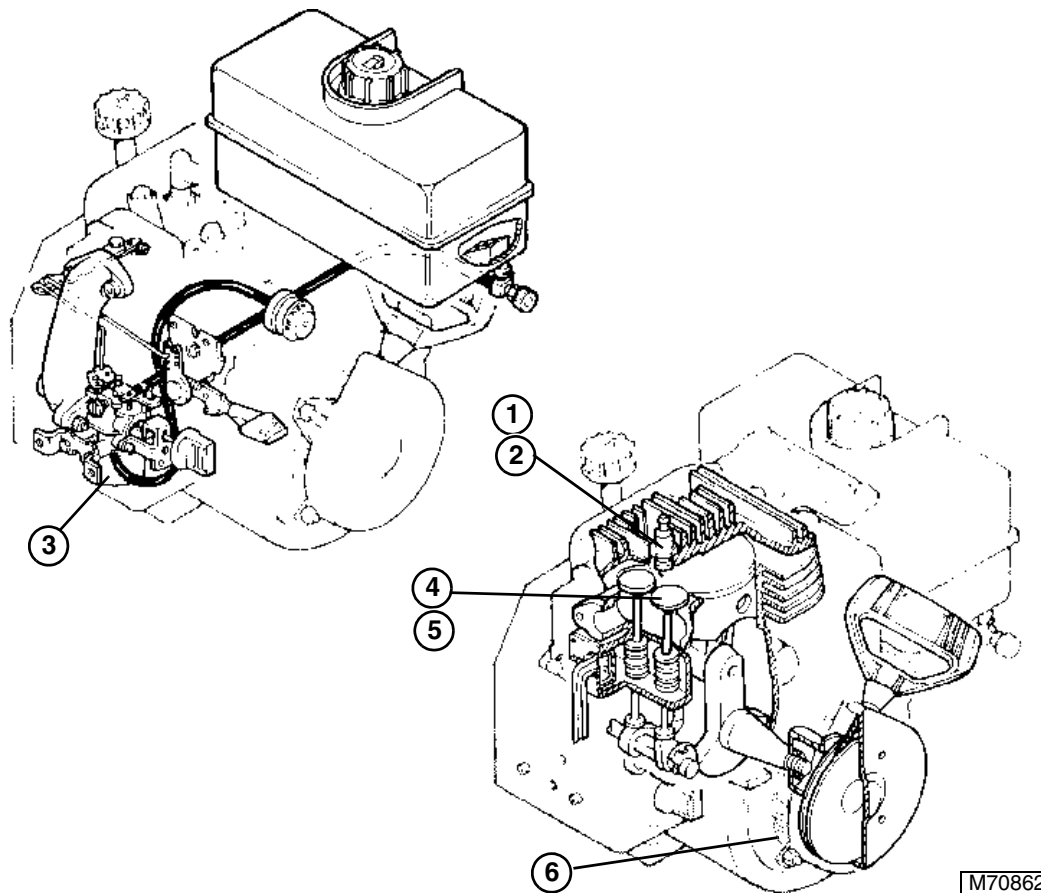

M70862

ENGINE BACKFIRES THROUGH CARBURETOR

Test Conditions:

- Key switch “OFF”
- Transmission control in “NEUTRAL”
- Auger drive disengaged
- Friction drive disengaged



Test/Check Point	Normal	If Not Normal
1. Spark plug (replace)	No improvement in performance	Spark plug was fouled.
2. Carburetor (check choke adjustment)	Fully open when set at “Off”	Adjust choke.
3. Valves (check clearance)	Intake and exhaust valve clearance is 0.10 mm (0.004 in.)	Adjust valves.
4. Valves (check valve lift)	Both open same amount	Replace camshaft.
5. Flywheel (inspect key)	Not sheared	Replace key.

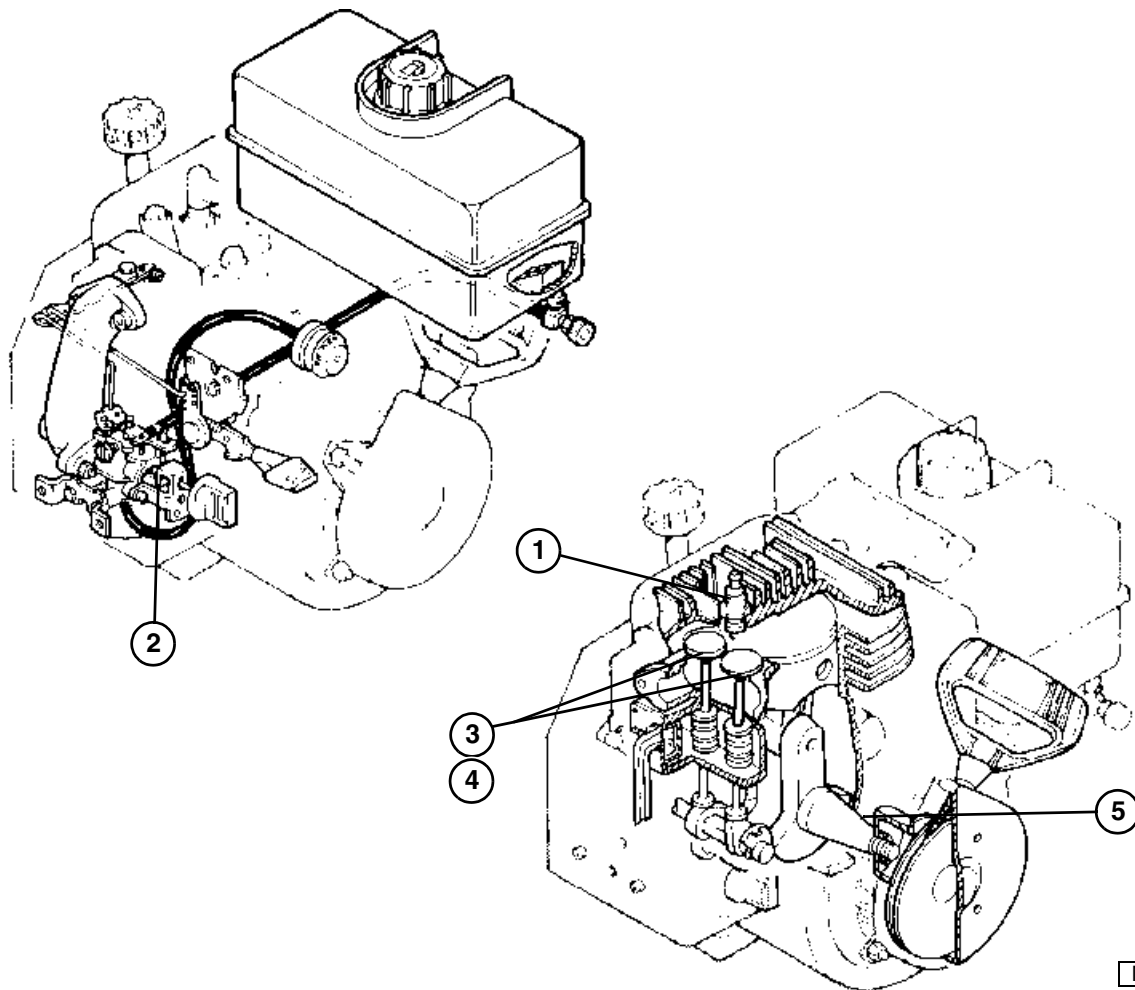

M70862

BLUE EXHAUST SMOKE OR OIL IN CARBURETOR HOUSING

Test Conditions:

- Key switch "OFF"
- Transmission control in "NEUTRAL"
- Auger drive disengaged
- Friction drive disengaged

Test/Check Point	Normal	If Not Normal
1. Dipstick (check oil level)	Below "Full" mark on dipstick	Drain oil.
2. Dipstick (inspect seals)	Not cracked	Replace.
3. Crankcase (test vacuum)	25 mm (1.0 in.) Water at fast idle	Perform necessary engine repairs.
4. Crankcase breather (inspect oil drain back hole)	Not plugged	Clean hole.
5. Cooling fins (inspect for debris)	Not plugged	Remove debris.

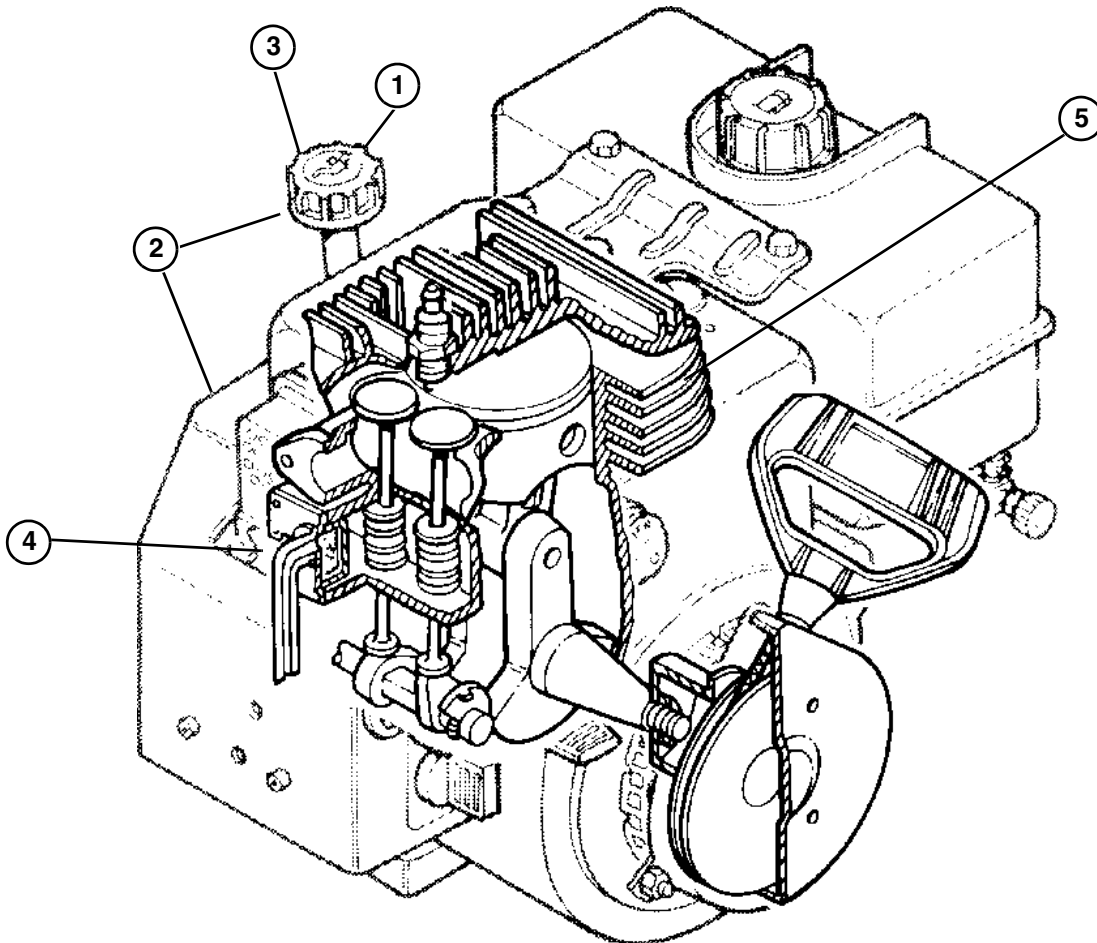

M70853

ENGINE MISS FIRES

Test Conditions:

- Key switch “OFF”
- Transmission control in “NEUTRAL”
- Auger drive disengaged
- Friction drive disengaged



Test/Check Point	Normal	If Not Normal
1. Spark plug (replace)	No change in engine performance.	Plug was fouled.
2. Spark plug (check for fuel)	Plug dry	Follow engine flooding test.
3. Carburetor (check choke adjustment)	Choke plate fully open with choke control at “Off”	Adjust choke.
4. Fuel supply (use external supply of known good fuel)	No change in engine performance	Drain system and add fresh fuel.
5. Carburetor (check high speed adjust)	Smooth idle at high rpm	Adjust high speed idle.
6. Carburetor (check float bowl drain assembly)	Fuel inlet and idle outlet holes open and clean	Clean assembly.
7. Valves (check clearance)	Intake and exhaust valve clearance is 0.10 mm (0.004 in.)	Adjust valves.
8. Valves (check valve lift)	Both open same amount	Replace camshaft.
9. Flywheel (inspect key)	Not sheared	Replace key.

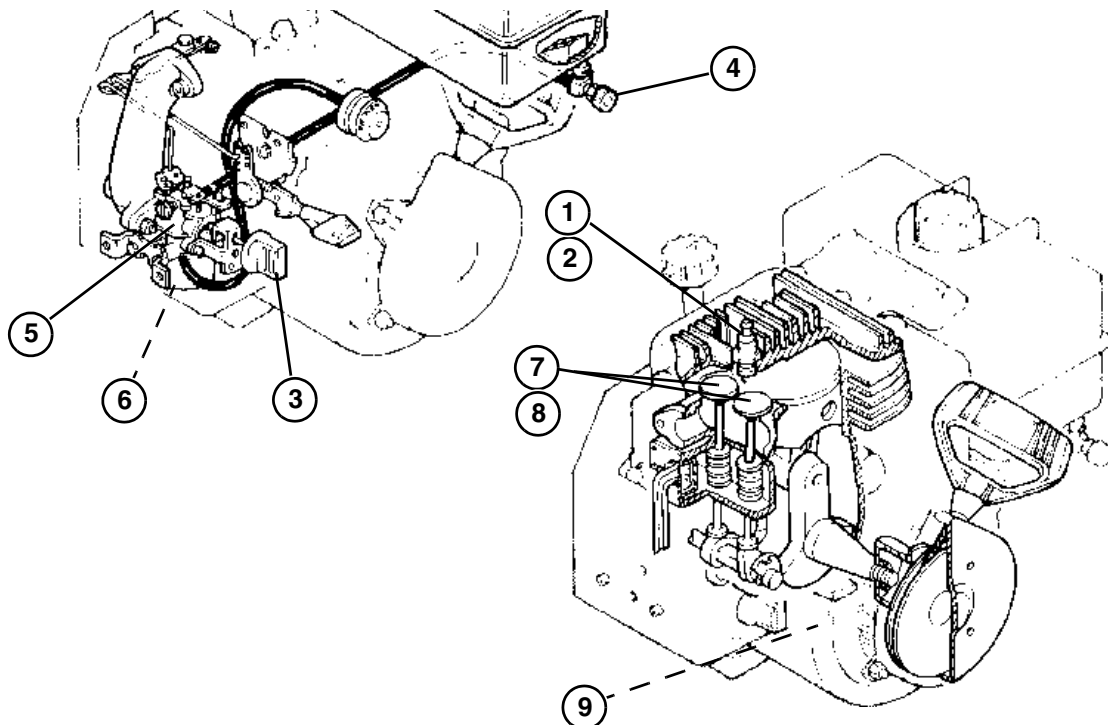

ENGINE USES TOO MUCH OIL

Test Conditions:

- Key switch "OFF"
- Transmission control in "NEUTRAL"
- Auger drive disengaged
- Friction drive disengaged

Test/Check Point	Normal	If Not Normal
1. Engine (inspect for leakage)	No leakage	Repair leakage.
2. Dipstick (check seal)	Not cracked	Replace seal.
3. Crankcase (test vacuum)	25 mm (1.0 in.) Water at fast idle	Perform necessary engine repairs.
4. Crankcase breather (inspect oil drain back hole)	Not plugged	Clean hole.
5. Internal engine (inspect for internal component wear)	None over specifications	Perform necessary engine repairs.

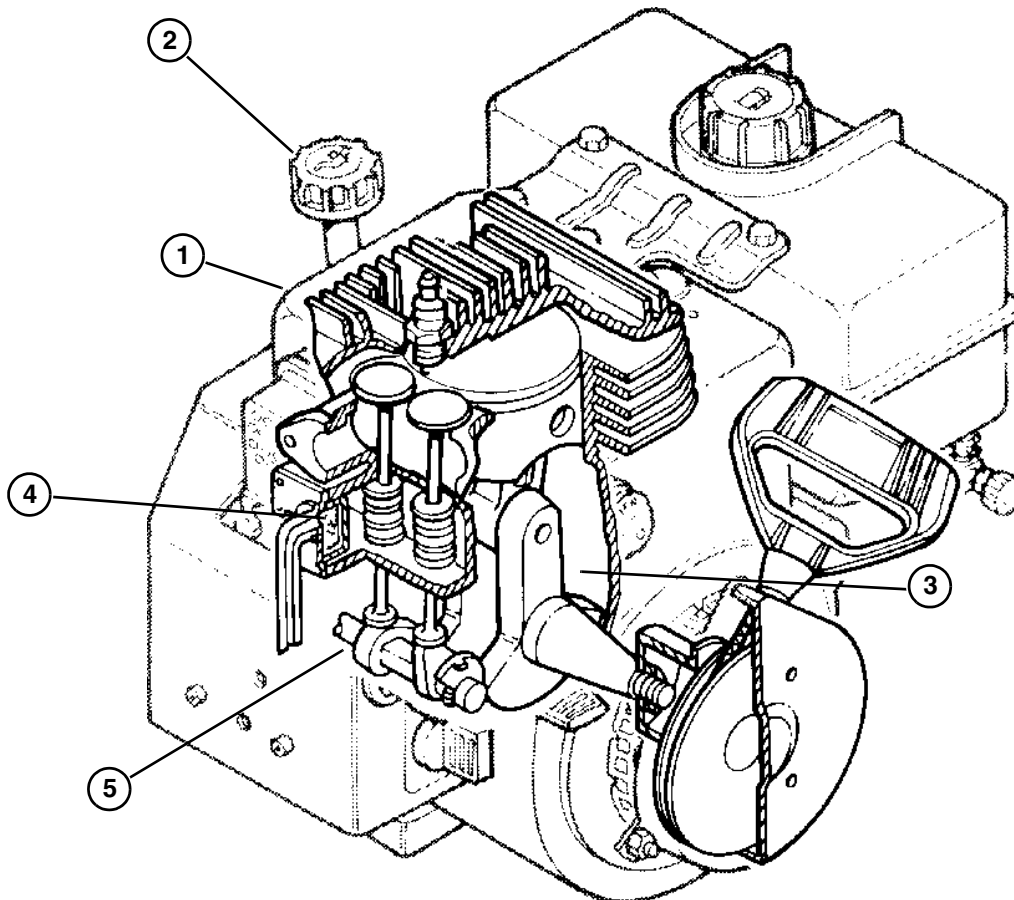

M70853

LACK OF FUEL IN CARBURETOR

Test Conditions:

- Key switch “OFF”
- Transmission control in “NEUTRAL”
- Auger drive disengaged
- Friction drive disengaged
- Fuel in tank



Test/Check Point	Normal	If Not Normal
1. Check fuel supply system for leaks	No leaks – fully operational.	Repair leaks and/or replace components.
2. Inspect fuel tank vent cap	No restriction – fully operational.	Clean or replace cap.
3. Fuel supply components	No restrictions – fully operational.	A–Inspect, clear, or replace tank screen. B–Inspect, clear, or replace fuel lines. C–Inspect, clear, or replace shut-off valve.
4. Primer and tube	No restrictions – fully operational.	Clear or replace primer and/or tube.

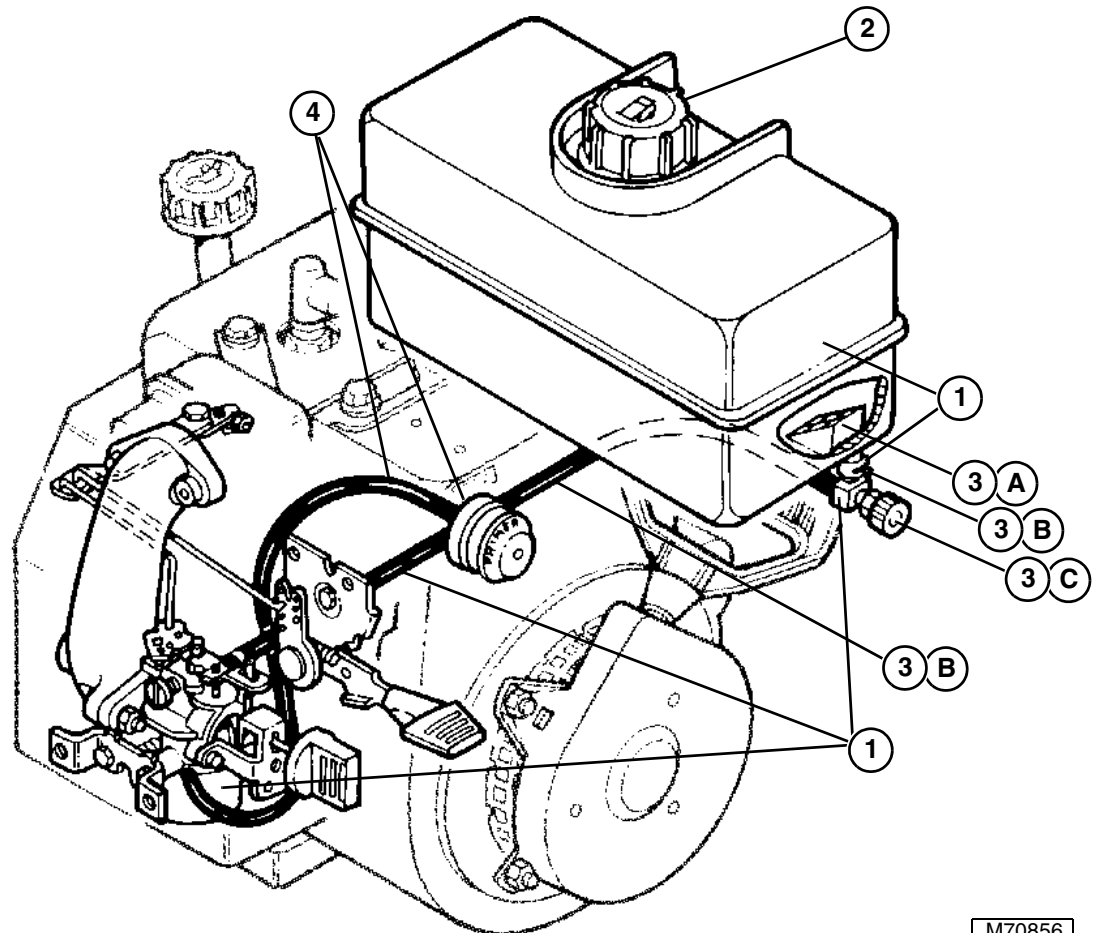

M70856

ENGINE FLOODED

Test Conditions:

- Key switch "OFF"
- Transmission control in "NEUTRAL"
- Auger drive disengaged
- Friction drive disengaged

Test/Check Point	Normal	If Not Normal
1. Carburetor – check choke lever operation	Fully open with control knob in "Off" position.	Adjust or replace linkage and/or replace carburetor.
2. Carburetor – inspect float	No fuel inside float – fully operational.	Adjust or replace float components.
3. Carburetor – inspect inlet needle and seat	Not worn – fully operational.	Adjust or replace needle and seat.

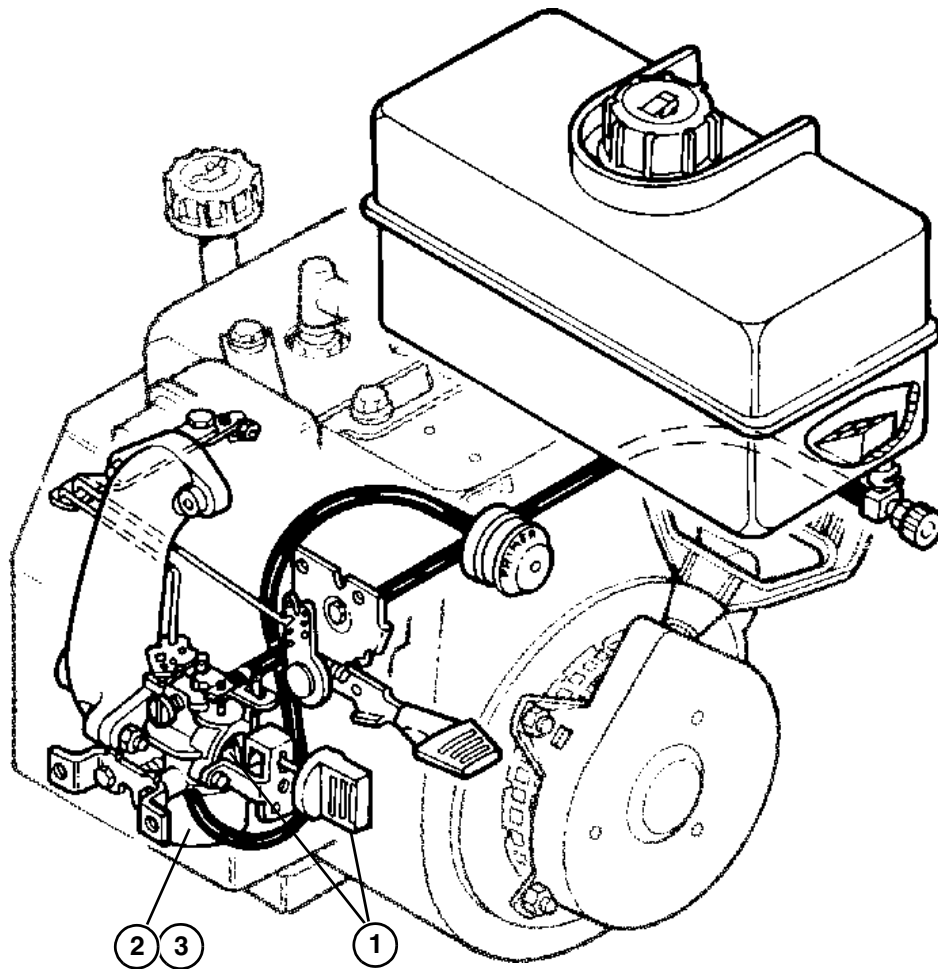

M70856

BACKFIRES THROUGH MUFFLER WHEN SHUT-OFF

NOTE: Allow engine to idle for 15 seconds before shutting off.

Test Conditions:

- Key switch "OFF"
- Transmission control in "NEUTRAL"
- Auger drive disengaged
- Friction drive disengaged



Test/Check Point	Normal	If Not Normal
1. Carburetor – check SLOW idle stop speed adjustment.	Set at specification (2000 ± 150 rpm).	Adjust SLOW idle stop speed.
2. Carburetor/Throttle Linkage – check float/needle valve and throttle linkage operation.	Fuel flow slows appropriately when throttle and float/needle valve are closed.	Adjust or replace throttle linkage and/or float/needle valve components.

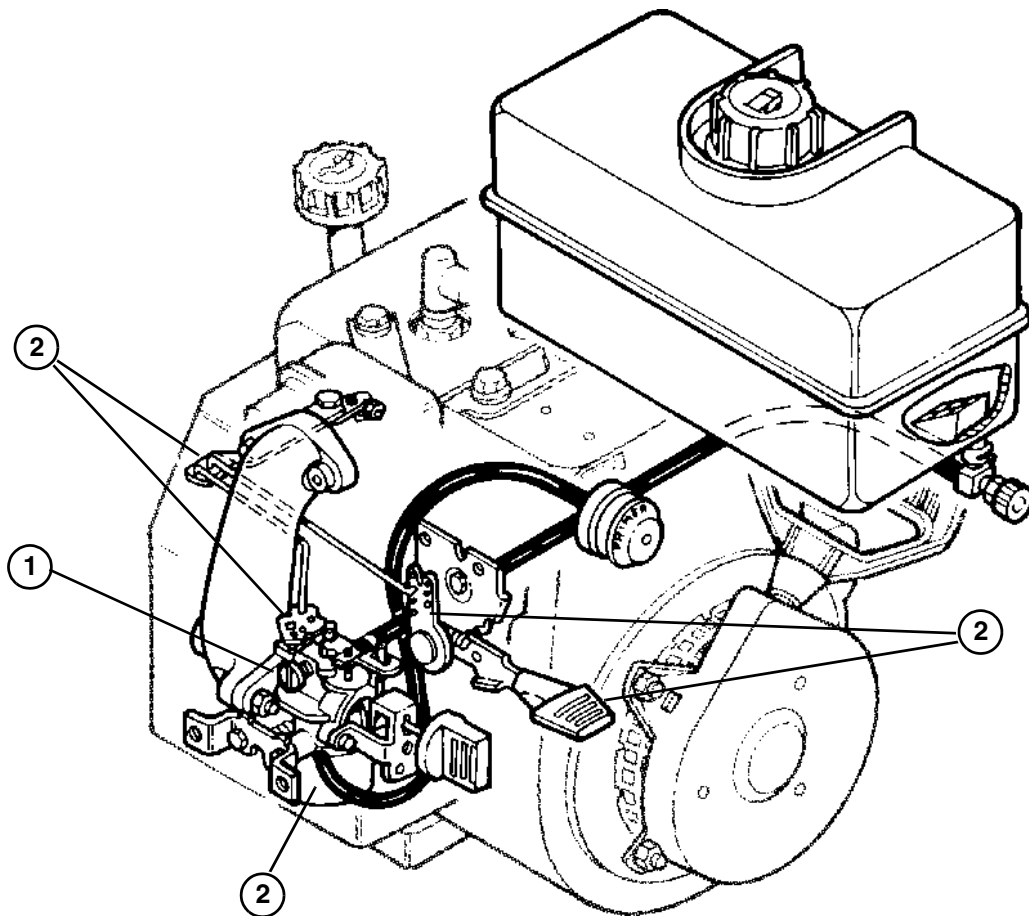

M70853

LOSES POWER OR RUNS ROUGH WHEN HOT

Test Conditions:

- Key switch “OFF”
- Transmission control in “NEUTRAL”
- Auger drive disengaged
- Friction drive disengaged

Test/Check Point	Normal	If Not Normal
1. Fuel tank – remove cap while engine is running	No change in engine performance – no restrictions.	Clean or replace fuel tank cap/vent.
2. Fuel supply – remove and check for fuel	Open flow of fuel – no restrictions.	A – Inspect and clean fuel tank screen. B – Inspect shut-off. C – Inspect fuel lines.
3. Muffler – check for restrictions	No restrictions.	Replace muffler.
4. Valves – check clearances	Intake and exhaust valve clearances within specification.	Adjust valves or replace all necessary valve train components.
5. Carburetor – inspect internal passages	No varnish, restrictions, or debris.	Clean passages.

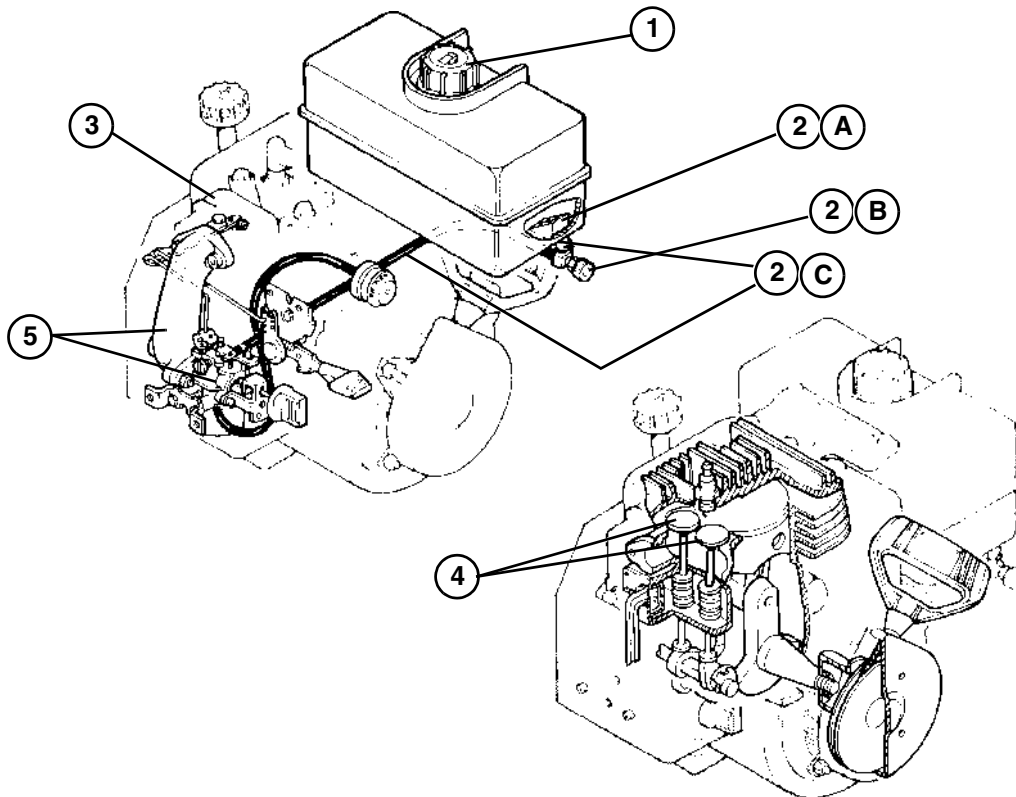

M70862



Suggest:

If the above button click is invalid.

Please download this document

first, and then click the above link

to download the complete manual.

Thank you so much for reading

ENGINE SURGES

NOTE: Surging is the result of a lean mixture (not enough fuel or too much air)

Test Conditions:

- Key switch "OFF"
- Transmission control in "NEUTRAL"
- Auger drive disengaged
- Friction drive disengaged



Test/Check Point	Normal	If Not Normal
1. Fuel tank – remove cap while engine is running	No change in engine performance.	Clean or repair fuel tank cap vent.
2. Carburetor – check choke linkage	Fully open with control at "Off" position.	Adjust or replace choke linkage.
3. Governor – inspect linkage and adjustment	Linkage free and adjusted properly.	Adjust governor or replace components.
4. Intake manifold – spray aerosol lubricant around intake gaskets while engine is running	No change in engine performance.	Replace gaskets.
5. Carburetor float bowl nut – check for plugging	Upper and lower holes open and clean.	Clean or replace nut.

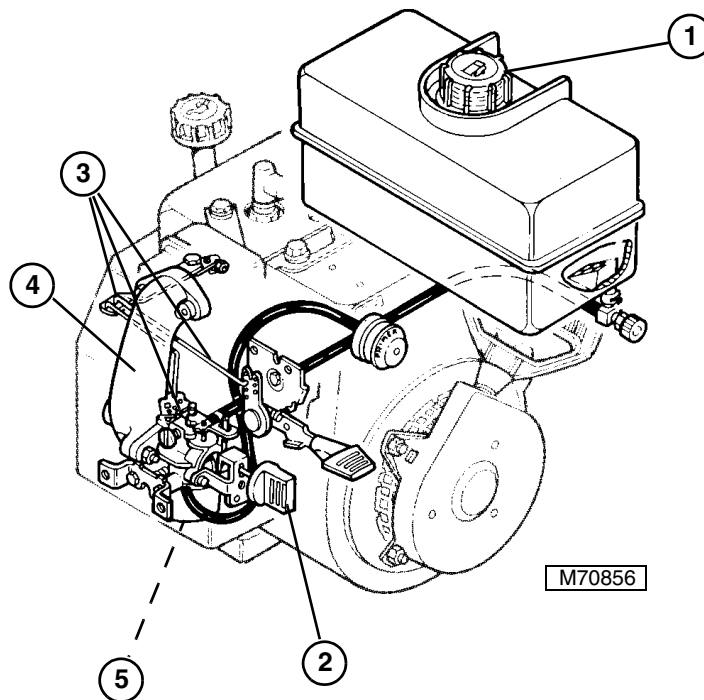

<https://www.ebooklibonline.com>

Hello dear friend!

Thank you very much for reading.

Enter the link into your browser.

The full manual is available for immediate download.

<https://www.ebooklibonline.com>