

# **Technical Manual**

## **John Deere 762 Scraper**

**John Deere Dubuque Works  
TM-1135**



Litho in U.S.A.

## SECTION AND GROUP CONTENTS OF THIS MANUAL

### SECTION I - GENERAL INFORMATION

- Group I - Contents, Index and Page Listing
- Group II - Introduction and Safety Information
- Group III - General Specifications
- Group IV - Predelivery, Delivery and After-Sale Services
- Group V - Lubrication

### SECTION 1 - WHEELS AND TIRES

- Group 0110 - Powered Wheels, Tires and Fastenings
- Group 0199 - Specifications and Special Tools

### SECTION 2 - AXLES AND SUSPENSION SYSTEMS

- Group 0201 - Drive Axle Housing and Support
- Group 0210 - Differential
- Group 0225 - Input Drive Shafts and U-Joints
- Group 0230 - Non-Powered Wheel Axles
- Group 0250 - Axle Shaft, Bearings and Reduction Gears
- Group 0299 - Specifications and Special Tools

### SECTION 3 - TRANSMISSION

- Group 0315 - Controls
- Group 0325 - Input Drive Shafts and U-Joints
- Group 0341 - Housings and Covers
- Group 0350 - Gears, Shafts, Bearings and Power Shift Clutch
- Group 0360 - Transmission Hydraulics
- Group 0399 - Specifications and Special Tools

### SECTION 4 - ENGINES

- Group 0400 - Engine Removal and Installation
- Group 0401 - Crankshaft and Main Bearings
- Group 0402 - Camshafts and Valve Actuating Means
- Group 0403 - Connecting Rods and Pistons
- Group 0404 - Cylinder Block (Liners)
- Group 0407 - Engine Oiling System
- Group 0408 - Ventilating System
- Group 0409 - Cylinder Head and Valves
- Group 0410 - Exhaust Manifold
- Group 0413 - Fuel Injection System
- Group 0414 - Intake Manifold
- Group 0416 - Turbocharger
- Group 0417 - Water Pump
- Group 0418 - Thermostats, Housings and Piping
- Group 0419 - Engine Oil Cooler
- Group 0420 - Fuel Filter
- Group 0421 - Fuel Transfer Pump
- Group 0422 - Starting System
- Group 0433 - Flywheel, Housing and Fasteners
- Group 0499 - Specifications and Special Tools

### SECTION 5 - ENGINE AUXILIARY SYSTEMS

- Group 0505 - Cold Weather Starting Aids
- Group 0510 - Engine Cooling Systems
- Group 0515 - Speed Controls
- Group 0520 - Intake System
- Group 0560 - External Fuel Supply Systems
- Group 0599 - Specifications and Special Tools

### SECTION 6 - TORQUE CONVERTER

- Group 0641 - Converter Housing and Cover
- Group 0651 - Converter Turbine, Gears, Shafts and Bearings
- Group 0699 - Specifications and Special Tools

### SECTION 9 - STEERING SYSTEM

- Group 0960 - Power Steering Hydraulic System
- Group 0999 - Specifications and Special Tools

### SECTION 10 - SERVICE BRAKES

- Group 1011 - Service Brakes Active Elements
- Group 1060 - Brakes Hydraulics
- Group 1099 - Specifications and Special Tools

### SECTION 11 - PARKING-EMERGENCY BRAKES

- Group 1111 - Parking Brake Active Elements
- Group 1115 - Controls Linkage
- Group 1199 - Specifications and Special Tools

### SECTION 13 - MISCELLANEOUS VEHICLE

- Group 1370 - Central Lubrication System for Sliding Floor Lever Pivots

### SECTION 16 - ELECTRICAL SYSTEMS

- Group 1671 - Batteries, Support and Cables
- Group 1672 - Alternator, Regulator and Charging System Wiring
- Group 1673 - Vehicle Lighting System
- Group 1674 - Wiring Harness and Switches
- Group 1676 - Instruments and Indicators
- Group 1699 - Specifications and Special Tools

### SECTION 17 - FRAME, CHASSIS, OR SUPPORTING STRUCTURE

- Group 1740 - Frame Installation
- Group 1799 - Specifications and Special Tools

## SECTION AND GROUP CONTENTS OF THIS MANUAL—Continued

### SECTION 18 - OPERATOR'S STATION

- Group 1806 - Safety Equipment
- Group 1810 - Operator Enclosure
- Group 1821 - Seat
- Group 1822 - Steps and Handholds
- Group 1830 - Heating and Air Conditioning
- Group 1899 - Specifications and Special Tools

### SECTION 19 - SHEET METAL

- Group 1910 - Hood or Engine Enclosure
- Group 1921 - Grille and Grille Housing
- Group 1927 - Fenders

### SECTION 21 - MAIN HYDRAULIC SYSTEM

- Group 2160 - Hydraulic System
- Group 2199 - Specifications and Special Tools

### SECTION 35 - SCRAPER AND HAULAGE DEVICE

- Group 3501 - Cutting Edge
- Group 3515 - Controls Linkage
- Group 3540 - Scraper and Haulage Device
- Group 3560 - Hydraulic System
- Group 3599 - Specifications and Special Tools

### SECTION 36 - CONVEYOR AND ELEVATING DEVICE

- Group 3615 - Controls Linkage
- Group 3640 - Conveyor and Elevating  
Device Frame
- Group 3650 - Gearbox
- Group 3660 - Hydraulic System
- Group 3699 - Specifications and Special Tools

### SECTION 90 - SYSTEM TESTING

- Group 9005 - General Information - Seven Basic  
Steps of Testing and Diagnosis
- Group 9010 - Engine
- Group 9015 - Electrical System
- Group 9020 - Power Train
- Group 9025 - Hydraulic System
- Group 9025A - Hydraulic System (Analyzer)
- Group 9030 - Miscellaneous Components
- Group 9035 - Specifications and Special Tools

**<https://www.ebooklibonline.com>**

Hello dear friend!

Thank you very much for reading.

Enter the link into your browser.

The full manual is available for immediate download.

**<https://www.ebooklibonline.com>**

## Group II INTRODUCTION AND SAFETY INFORMATION

### INTRODUCTION

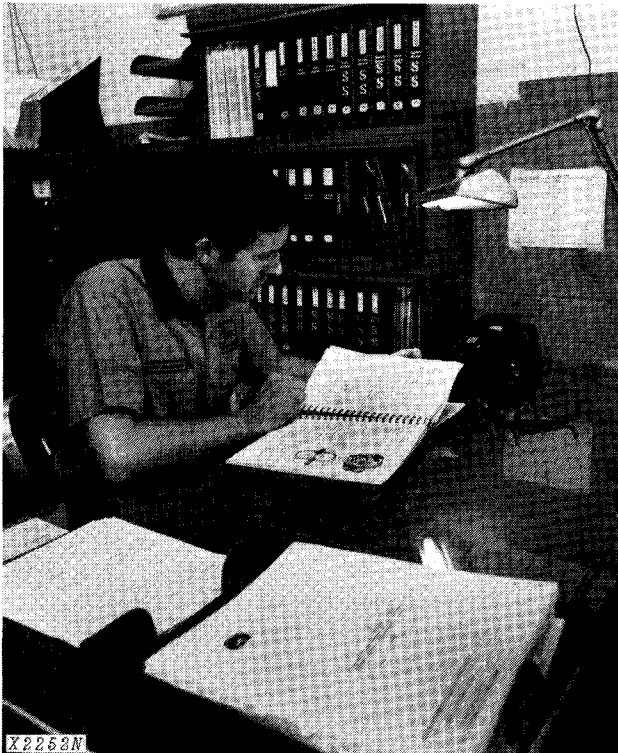

Use FOS Manuals for Reference



Use Technical Manuals for Actual Service

This technical manual is part of a twin concept of service:

The two kinds of manuals work as a team to give you both the general background and technical details of shop service.

#### •FOS Manuals—for reference

*Fundamentals of Service (FOS) Manuals* cover basic theory of operation, *fundamentals* of trouble shooting, *general* maintenance, and *basic* types of failures and their causes. FOS Manuals are for training new personnel and for reference by experienced service technicians.



When a service technician should refer to a FOS Manual for more information, a FOS symbol like the one at the left is used in the technical manual.

#### •Technical Manuals—for actual service

*Technical Manuals* are concise service guides for *specific* machines. Technical manuals are on-the-job guides containing only the vital information needed by an experienced service technician.

Litho in U.S.A.

This technical manual was written for you—an experienced service technician. Keep it in a permanent binder in the shop where it is handy. Read it when you need to know correct service procedures or specifications.

Some features of this manual:

- Inside front cover - "Table of Contents".
- Section I - Contents, safety information, general specifications and general services.
- Sections 1 through 36 - Removal, repair, testing (components removed), installation, and adjustment.
- Section 90 - Detailed explanation of system operation, diagnosis, visual inspection, testing, and adjustments.
- Specifications are listed and illustrated at the end of each section.

# MAINTENANCE WITHOUT ACCIDENT WORK SAFELY



T27999N

 This safety symbol is used for important safety messages. When you see this symbol, follow the safety message to avoid personal injury.

**EVERY EMPLOYER HAS A  
SAFETY PROGRAM. KNOW  
WHAT IT IS!**

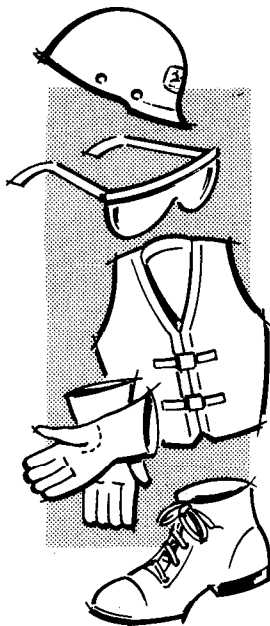

T27501N

See your shop supervisor for specific instructions on a job, and the safety equipment required.

For instance, you may need: Hard hat, safety shoes, safety goggles, heavy gloves, reflector vests, ear protectors, respirator.

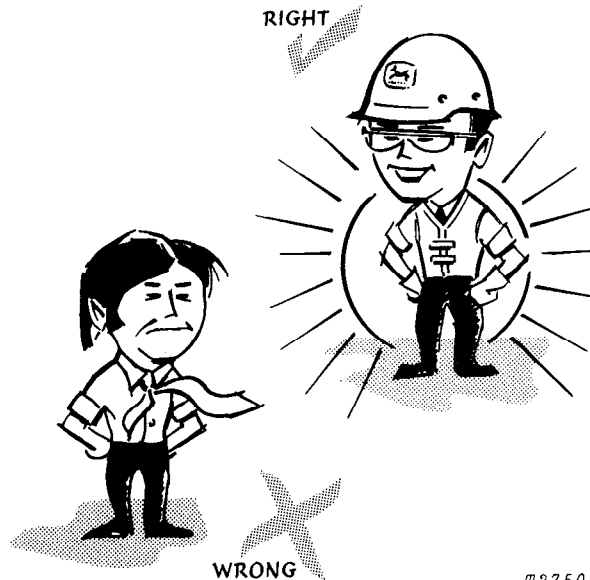

## BE ALERT!

Plan ahead — work safely — know how to use a first aid kit and a fire extinguisher — and where to get assistance.

T27502N

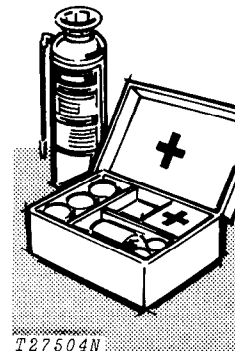

T27504N

## Maintenance Area

Make sure the maintenance area has enough ventilation.

Keep the maintenance area **CLEAN AND DRY**. Oily and wet floors are slippery. Greasy rags are a fire hazard. Wet spots are dangerous when working with electrical equipment.

Keep starting aids in a cool, well-ventilated place, out of reach of unauthorized personnel.

## MAINTENANCE WITHOUT ACCIDENT

### AVOID FIRE HAZARDS -

#### Fuel Is Dangerous!

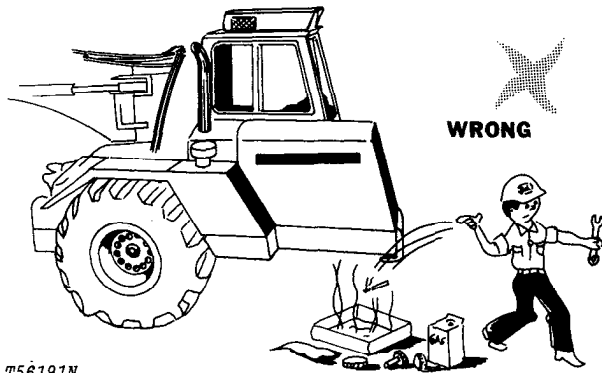

T56191N

Do not smoke while putting fuel in the fuel tank.

Do not smoke while working with material that will start on fire easily.

Stop the engine before filling the fuel tank.

Do not use gasoline or diesel fuel for cleaning parts. Use solvents that will not start on fire.

#### Battery Gas Is Highly Flammable!

When charging batteries, be sure there is enough ventilation.



T27506N

Do not check the battery charge by putting metal objects across the posts.

Do not let sparks or open flame near batteries.

Do not smoke near battery.

#### Flame Is Not a Flashlight!

**NEVER USE OPEN FLAME AROUND THE MACHINE.**

**KNOW WHERE FIRE EXTINGUISHERS ARE KEPT!**

### UNDER ALL MAINTENANCE CONDITIONS -

Do not work on the equipment unless you are approved to do so. Then be sure you know the safe and correct procedure.

Never work on equipment while it is being operated.

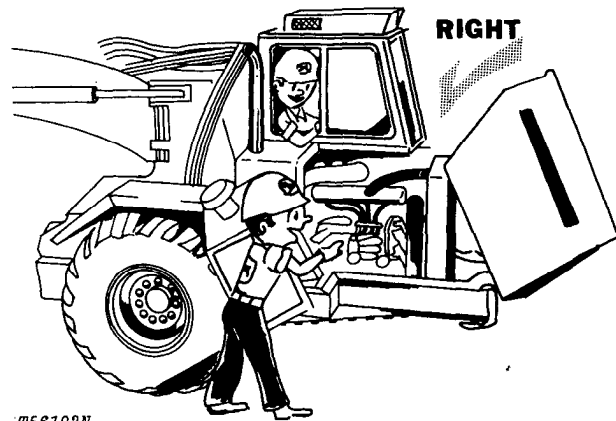

T56192N

When the engine is running, avoid working on equipment.

If you must work on the machine with the engine running, ALWAYS USE TWO service technicians. One must be at the controls. The other must be within sight of the operator.

#### KEEP HANDS AWAY FROM MOVING PARTS.

Put a support under all raised equipment.

Never work under a raised bowl.

Lower the bowl to the ground.

If the machine is on a slope, use blocks to hold it in place.

Do not lift heavy parts by yourself. Use hoisting equipment for this.

#### TAKE CARE! WATCH OUT FOR OTHER PEOPLE IN THE AREA.

When drilling, grinding, or hammering metal, wear safety glasses.

## BE CAREFUL DURING SERVICE AND REPAIR

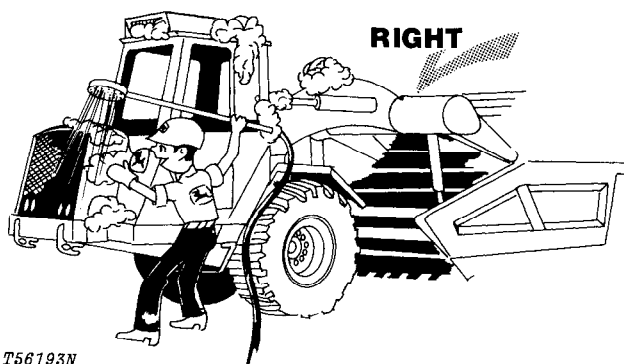

Keep ALL equipment free of dirt and oil.

Clean oil, grease, mud, ice or snow from the operator's station, steps and hand rails.

When getting the engine ready for storage, remember that inhibitor changes easily into gas and is dangerous. After adding the inhibitor, seal and tape openings. When you are not using the inhibitor, keep the can tightly closed.

Do not remove the radiator cap unless you can hold your hand on the radiator tank. First, loosen the cap slowly to the stop. Then release all pressure in the cooling system before removing the cap.

Check the exhaust system regularly for leaks.

Release hydraulic pressure before working on the hydraulic system. Stop the engine. Lower the bowl to the ground. Move the control levers until the bowl does not move.

When checking hydraulic pressure, be sure to use the correct test gauge.

Before working on the fuel system, close the fuel shutoff valve.

Before working on the electrical system, or making a major overhaul, disconnect the batteries.

## KNOW EQUIPMENT IS READY!

Check all guards, shields, and safety bars. Every one must be in place and tight.

### CHECK IT OUT!

- GUARDS
- SHIELDS
- SAFETY BARS
- ROLL-OVER PROTECTIVE STRUCTURES
- SEAT BELTS, ETC.



Carefully inspect all systems for leaks.

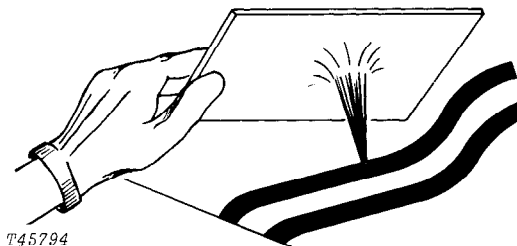

Use a piece of cardboard or wood, rather than hands, to search for suspected leaks.

Escaping fluid under pressure can penetrate the skin.

If injured by escaping fluid, see a doctor at once.

## Group III GENERAL SPECIFICATIONS

(Specifications and design are subject to change without notice. Wherever applicable, specifications are in accordance with SAE Standards. Except where otherwise noted, these specifications are based on a unit equipped with 23.5-25, 16-ply-rating tires and standard equipment.)

### Capacity (SAE heaped):

Volume ..... 11 cu. yd. (8.41 m<sup>3</sup>)  
Total weight of payload @  
2500 lb/yd<sup>3</sup> (1483 kg/m<sup>3</sup>) . 27,500 lb. (12 474 kg)

**Power** (@ 2100 engine rpm):      SAE      DIN  
Gross ..... 190 hp (141.7 kW\*)  
Net ..... 175 hp (130.5 kW)      (177.5 PS)  
Net engine flywheel power is for an engine equipped with fan, air cleaner, water pump, lubricating oil pump, fuel pump, alternator, and muffler. Gross engine power is without fan. Flywheel power ratings are under SAE standard conditions of 500 ft. (150 m) altitude and 85°F (29°C) temperature and DIN 70 020 conditions (non-corrected). No derating is required up to 10,000 ft. (3 000 m) altitude.

\*In the International System of Units (SI), power is expressed in kilowatts (kW).

### Engine: John Deere Turbocharged diesel, 6-cylinder, 4-stroke cycle

Bore and stroke ..... 5.12x5 in. (130x127 mm)  
Piston displacement ..... 619 cu. in. (10 144 cm<sup>3</sup>)  
Compression ratio ..... 15.2 to 1  
Maximum torque  
    @1300 rpm ..... 550 lb-ft (746 Nm) (76 kg-m)  
NACC or AMA (U.S. Tax) horsepower ..... 62.9  
Main bearings ..... 7  
Lubrication ..... Pressure system with full flow filter  
Cooling ..... Pressurized with thermostat and fixed bypass  
Fan ..... Suction  
Air cleaner with restriction indicator ..... Dry  
Electrical system ..... 24 volt with alternator  
Batteries (two) ..... Reserve capacity: 180 minutes

### Transmission:

Two-phase, single-stage torque converter with lockup clutch and Power Shift transmission (5 speeds forward - 1 reverse). Stall ratio is 1.82 to 1.

**Differential Lock** ..... Foot operated, hydraulically actuated

**Drive Axle** ..... Differential drive; over-all ratio 17.98 to 1; planetary final drives

**Brakes:** Hydraulic, power actuated. Tractor and scraper brakes are operated simultaneously. An accumulator provides several brake applications after engine is stopped.

Tractor ..... Wet-disk between differential and planetaries.

No adjustment needed.

Scraper ..... Expanding shoe, at wheels.

Parking ..... Manually controlled, expanding shoe, mechanical, on axle input shaft.

**Power Steering:** Position-responsive with hydraulic follow-up.

Turning circle (180 deg. turn) ..... 30 ft. (9.14 m)

Angle of steer right or left ..... 90 deg.

**Tractor Oscillation** (total) ..... 27 deg.

### Hydraulic Systems:

Main tractor system: Closed-center

System pressure . 2250 psi (155 bar) (158 kg/cm<sup>2</sup>)

Operates steering, brakes, differential lock and all scraper functions except elevator drive.

Main pump... Variable displacement, constant pressure delivers 34.6 gpm (131 L/min) @ 2100 rpm.

Main charge pump delivers 13 gpm (49 L/min) @ 2142 rpm.

Elevator system... Engine-driven 4.26 cu. in. (69.8 cm<sup>3</sup>) variable displacement, reversible hydrostatic pump delivers 36.6 gpm (138.5 L/min) @ 2142 rpm.

System pressure ..... 5000 psi (34,500 kPa) (351 kg/cm<sup>2</sup>)

Filtration ..... All systems are protected by replaceable filters.

Main hydraulic system ..... 10 micron filters

Elevator system ..... 10 micron filters

Transmission ..... 40 micron filters

Engine ..... 25 micron filters

Air cleaner ..... Dry-type with safety element and restriction indicator

Hydraulic Cylinders:	Bore	Stroke
Lift (two) .....	4.5 in. (114 mm)	18 in. (457 mm)
Sliding floor (one) .....	5.25 in. (133 mm)	30.1 in. (765 mm)
Ejector gate (two) .....	2.5 in. (64 mm)	34.8 in. (884 mm)
Steering (two) .....	3.5 in. (89 mm)	25.89 in. (658 mm)
Piston rods ...	Ground, heat-treated, chrome-plated, polished	
Lift and steering cylinders .....	2 in. (51 mm)	
Sliding floor cylinders .....	2.25 in. (57 mm)	
Ejector gate cylinders .....	1.50 in. (38 mm)	

**Elevator** .. Reversible, hydrostatic-drive with triple gear reduction  
 Number of flights .. 18  
 Spacing of flights .. 12.44 in. (316 mm)  
 Width of flights .. 5 ft. 6.9 in. (1.7 m)  
 Speed (variable) .. 0 to 236 fpm (0 to 72 m/min)  
 Length (top to bottom) .. 9 ft. 6 in. (2.9 m)

**Bowl** ... Heavy gauge steel with reinforcing and box construction. Sliding floor rides on heat-treated, replaceable rails. Cutting edge retracts with sliding floor. Independent axles are vertically adjustable.

**Cutting Edge** ... 7 ft. 6 in. (2.29 m) wide; 3 sections, reversible and replaceable, high-carbon steel. Each section is adjustable vertically 2 in. (51 mm).  
 Center section ... 0.75x10x54 in. (19x254x1 372 mm)  
 End sections ... 0.75x10x18 in. (19x254x457 mm)

**Tires:**  
 23.5, 16-ply-rating, E2  
 23.5-25, 16-ply-rating, E3  
 23.5-25, steel-cord radials

Capacities	U.S. Gallons	Liters
Cooling system .....	9	34.1
Fuel tank .....	72	272.5
Engine lubrication, including filter .....	5.5	20.8
Transmission case and filter .....	12	45.4
Differential case .....	5.5	20.8
Hydraulic reservoir .....	7.5	28.4
Elevator gear case .....	4.25	16.2

Additional Standard Equipment:	
Gauges:	Fenders (tractor and scraper)
Tachometer	Horn
Hour meter	Driving lights
Speedometer	Transmission bottom guard
Oil pressure	Independent, adjustable scraper axles
Coolant temperature	Foot throttle
Transmission pressure	Differential lock
Converter temperature	Vandal protection
Hydrostatic charge pressure	Muffler
Indicators	Reverse warning horn
Turn signal	Central lube system
Alternator	ROPS canopy with seatbelt and tether straps
Brake pressure	Bucket seat
Parking brake	Windshield with wiper
High beam	Regular side cutters
Hydraulic filter	Engine coolant conditioner-filter
Cold weather starting aid	

Weight Distribution:	lb.	kg
Empty: Drive axle .....	22,310	10 120
Scraper axle .....	12,140	5 507
Total .....	34,450	15 627
Loaded: Drive axle .....	31,110	14 111
Scraper axle .....	30,840	13 989
Total .....	61,950	28,100

**Special Equipment:**  
 Teeth for cutting edge  
 ROPS cab  
 Air conditioning  
 Cab heater  
 Extended side cutters  
 Ejector gate spill screen  
 Mud flaps for scraper wheels

**JD762 SCRAPER DIMENSIONS**

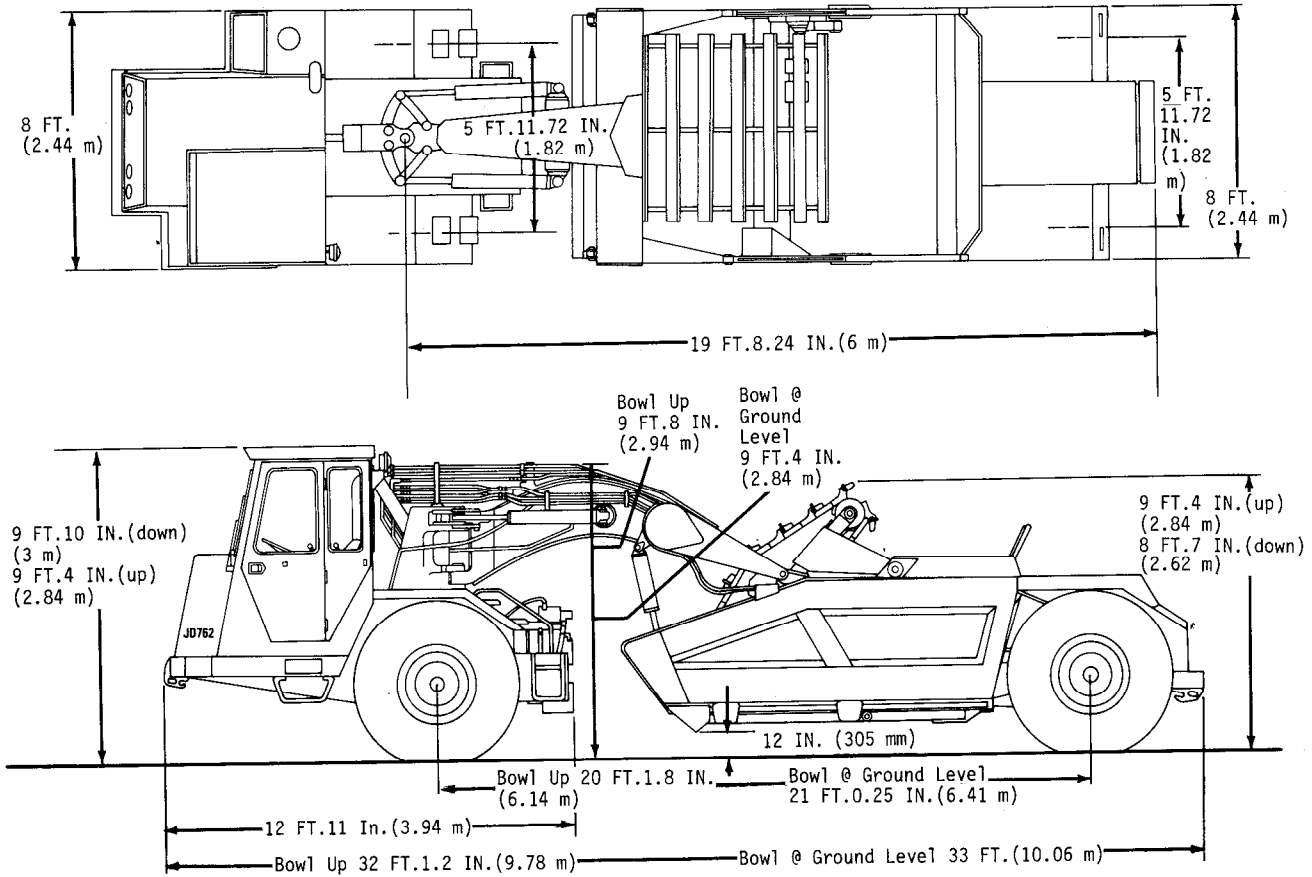

T56462N

# Group IV PREDELIVERY, DELIVERY, AND AFTER-SALE SERVICES

## TEMPORARY STORAGE

After receiving your scraper from the factory and before putting the machine into temporary storage, make the following checks and perform the services:

For information on storage over 30 days, see your JD762 Operator's Manual.

1. Check the battery electrolyte level. Charge the battery, if necessary.
2. Check the level of the coolant in the radiator. The coolant must be in the sight glass when the engine is off and cold.
3. Fill the fuel tank.
4. Check the crankcase oil level. Oil must be between marks on the dipstick after the engine has been stopped for 10 minutes.
5. Release hydraulic pressure by stopping the engine, lowering the bowl, and operating the control levers until the bowl does not move.

## PREDELIVERY SERVICE

The service technician must carefully check and service the machine before the dealer delivers it to the customer. When the customer receives a machine that is correctly prepared, the customer is well-satisfied. For these reasons, correct predelivery service is very important to the dealer and the customer.

Use the following list when getting a unit ready for delivery to the customer.

## 1. Service Equipment

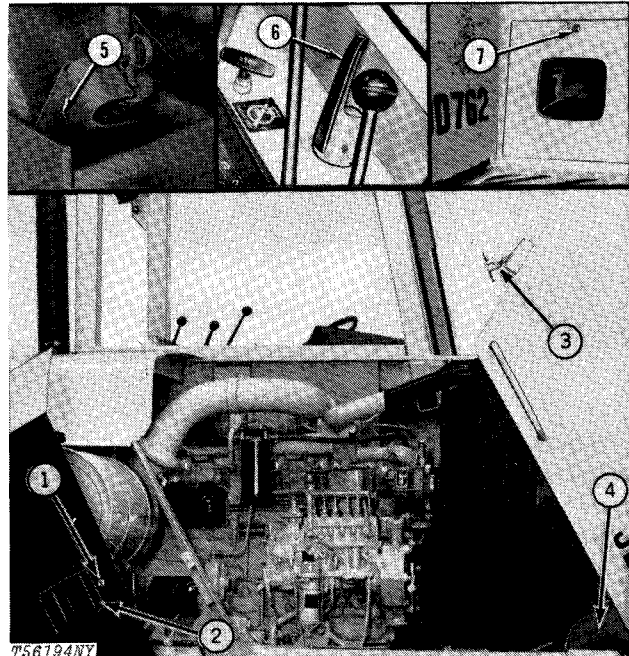

- |                             |                              |
|-----------------------------|------------------------------|
| 1—Service Door Lock         | 4—Hood Latch                 |
| 2—Service Door Latch Handle | 5—Transmission Dipstick Lock |
| 3—Rubber Hook               | 6—Hood Release Lock          |
|                             | 7—Front Access Door Lock     |

Fig. 1-Service Equipment

Use the ignition key to check the operation of the service door lock (1), front access door lock (7), hood release lock (6), and transmission dipstick lock (5). Lubricate if necessary.

Check the operation of the service door latch (2), hood rubber hook (3), and hood latch (4).

Service equipment checked	Yes	No
---------------------------	-----	----

## 2. Batteries

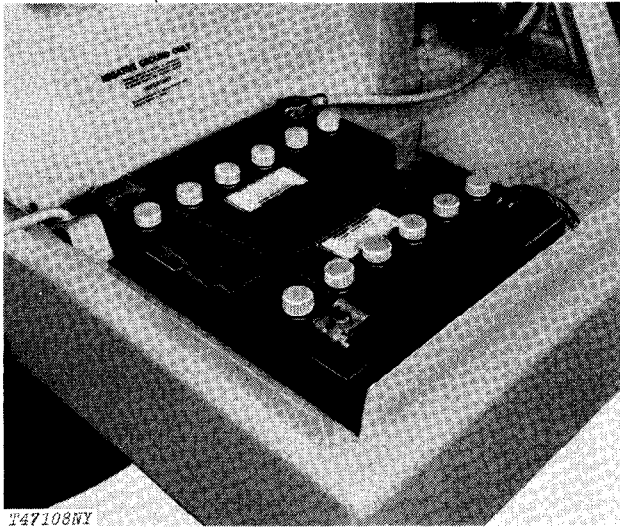

Fig. 2-Batteries

Check the electrolyte level of the batteries. If distilled water is not available, use clean soft water. Do not use hard water. Remove dirt from the top of the batteries with a damp cloth. Put petroleum jelly on terminals.

**IMPORTANT:** Never add water to the batteries in freezing weather unless the engine will be run 2 or 3 hours.

Check battery connections.

Punch date code on battery.

Batteries checked Yes No

## 3. Air Cleaner

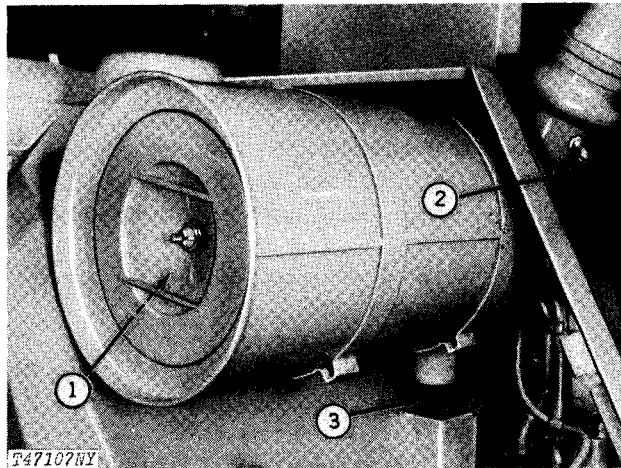

1—Primary Element 3—Dust Unloader Valve  
 2—Restriction Indicator

Fig. 3-Air Cleaner Primary Element

Check the air filter restriction indicator (2). If the red signal can be fully seen, check the air intake system for a restriction.

Air cleaner checked Yes No

#### 4. Air Intake Hoses

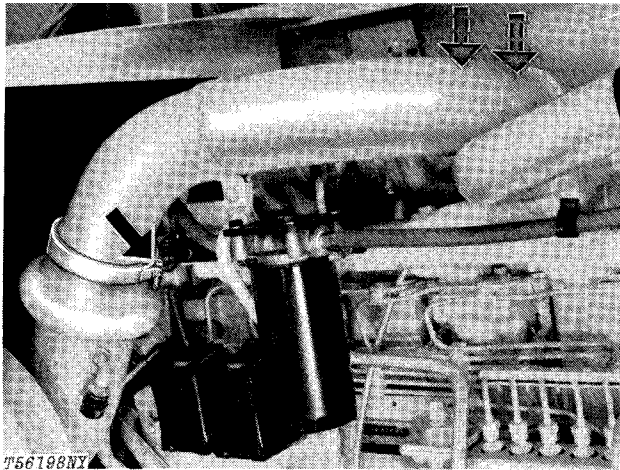
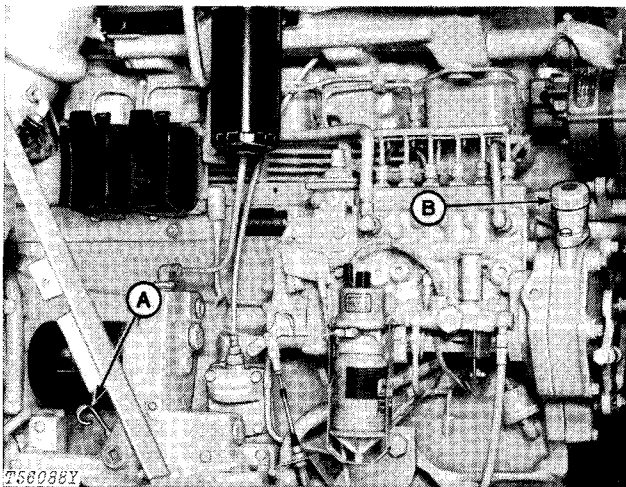

Fig. 4-Air Intake Hose Connections

Inspect clamps on hoses connecting the air cleaner and the engine. Tighten the hose clamps.

Air intake hoses checked Yes No

#### 5. Crankcase Oil Level



A—Dipstick

B—Filler Cap

Fig. 5-Crankcase Oil Level

Check the oil level when the scraper is on a level surface. Wait ten minutes after stopping the engine before checking the oil level. If the oil level is at or below the bottom mark on the dipstick, add oil specified on page I-V-2. Do not operate the engine with the oil level below the bottom mark. Keep the oil level between the marks on the dipstick.

Crankcase oil level checked Yes No

Oil added qts. (L)

#### 6. Fuel Filters

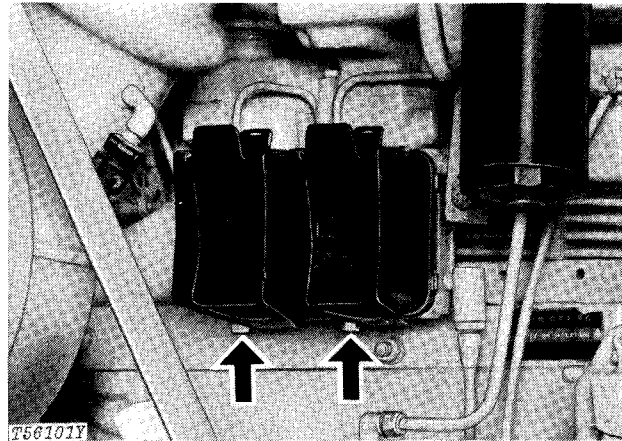

Fig. 6-Fuel Filter Drain Screws

Check the fuel filters. Drain sediment, if necessary. Loosen the drain screws.

Drain all water and sediment.

Tighten the drain screws.

Remove air from the fuel system.

#### Removing Air from the Fuel System

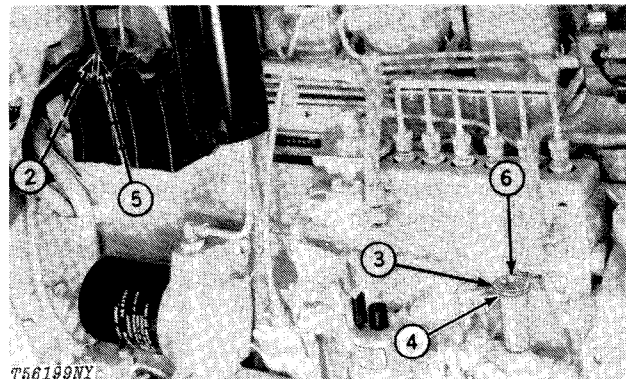

Fig. 7-Removing Air From Fuel System

- 1 - Turn the key on.
- 2 - Loosen the bleed screw.
- 3 - Turn the hand primer counterclockwise to loosen it.
- 4 - Pull the hand primer up. Pump the primer until a solid stream of fuel, free from air bubbles, comes from the bleed screw.
- 5 - Tighten the bleed screw.
- 6 - Push the hand primer down completely. Turn the knob clockwise by hand to tighten it. Turn the key off.

Fuel filters checked Yes No

Air removed from system Yes No

## 7. Belt Tension

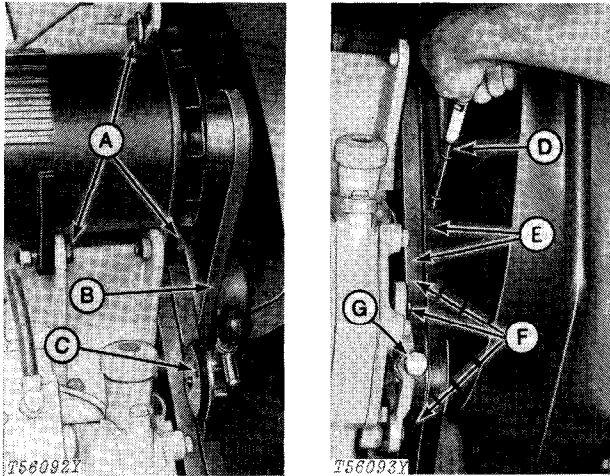

A—Cap Screws (3)  
 B—Alternator Belt  
 C—Strand Tension Gauge

D—Tension Tester  
 E—Fan Belts  
 F—Cap Screws (3)  
 G—Jack Screw

Fig. 8-Checking and Changing Belt Tension

### Checking Tension

Strand Tension Gauge (C): Belts must have 90 lb. (400 N) (41 kg) strand tension. Check the front fan belt only.

Tension Tester (D): A 14 lb. (62 N) (6 kg) force halfway between the pulleys must move the belt 1/2 in. (13 mm).

Immediately after stopping the engine (run the engine 5 minutes or more), check the belt tension. If tension is less than 50 lb. (223 N) (23 kg), wait ten minutes. Then change tension to 90 lb. (400 N) (41 kg).

### Adjusting Tension

Alternator belt: Loosen three cap screws (A). Move only the FRONT alternator frame to change belt tension. Tighten the cap screws

Fan belts: Loosen three cap screws (F) and lock nut on the jack screw (G). Turn the jack screw clockwise to tighten belts. Tighten the cap screws and lock nut.

**NOTE:** The compressor belt must move 3/8 in. (10 mm) when 10 to 15 lb. (45 to 67 N) (5 to 7 kg) force is applied halfway between pulleys.

Belt tension checked Yes No

## 8. Cold Weather Starting Aid

Check the cold weather starting aid. Remove the can of starting fluid. Push the starting aid button (beneath the turn signal toggle switches). If the solenoid “clicks”, the starting aid system is working correctly. Install the can of starting fluid.

Cold weather starting aid checked Yes No

## 9. Radiator

**CAUTION:** Do not remove the radiator filler cap unless you can hold your hand on the radiator tank. First, loosen the cap slowly to the stop. Then release all pressure in the cooling system before removing the cap.

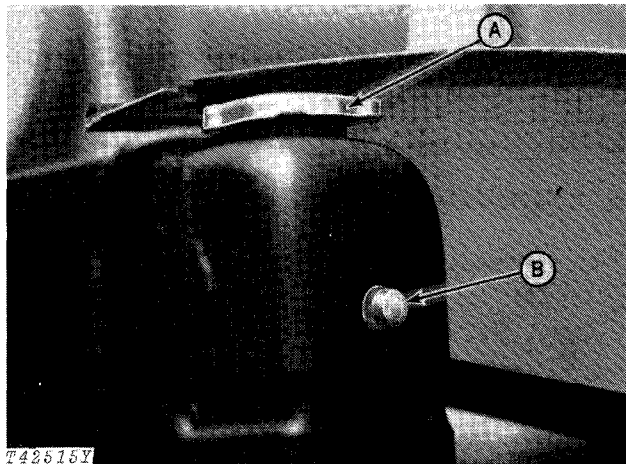

A—Filler Cap B—Sight Glass

Fig. 9-Radiator Filler Cap and Sight Glass

Check the level of the coolant in the radiator. Coolant must be in the sight glass when the engine is off and cold. Use clean water for warm weather. Use a solution of 50% clean water and 50% permanent anti-freeze (ethylene glycol with approved rust inhibitor) for cold weather.

Check the cooling system for loose connections and leaks. Remove trash from the radiator.

Be sure the shut-off valves are open on the coolant conditioner-filter.

Coolant level checked Yes No



### 13. Electric Fuel Pump

The electric fuel pump is in the left (L.H.) rear side of the scraper bowl next to the fuel tank.

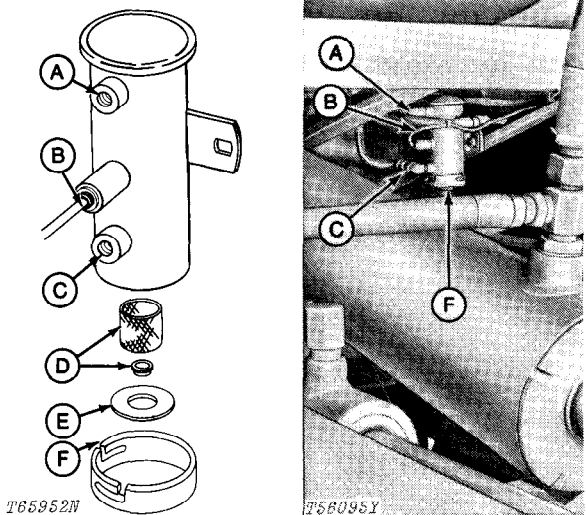

A—Fuel Outlet  
 B—Wiring Lead  
 C—Fuel Inlet

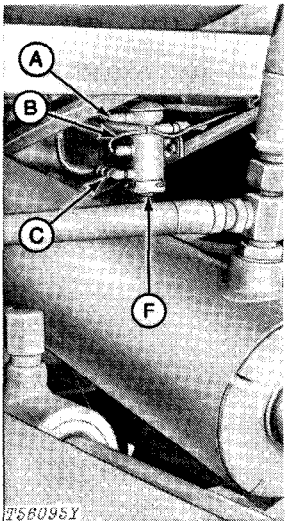

D—Filter and Magnet  
 E—Gasket  
 F—Bottom Cover

Fig. 13-Electric Fuel Pump

Close the fuel tank shut-off valve.

Remove cover (F), gasket (E), magnet and filter (D). Clean the magnet. If the filter is dirty or damaged, install a new one.

Install the magnet and filter, cover, and gasket. Open the shut-off valve.

Remove air from the fuel system. (See page I-IV-3).

New filter installed Yes No

Air removed from fuel system Yes No

### 14. Tire Pressure

Check the air pressure in all tires with an accurate gauge having 1 psi (7 kPa) graduations.

**IMPORTANT:** Tire pressure can be changed to suit working conditions, according to tire manufacturer's recommendations.

The following chart shows correct tire pressure.

Tire Size	Ply Rating	Inflation Pressures PSI (kPa)
23.5-25	16 (E2)	35 (240)
23.5-25	16 (E3)	35 (240)
23.5-25	Radial	45 (310)

Tire pressure checked Yes No

### 15. Grease Fittings

All grease fittings were checked and lubricated before the scraper left the factory. However, to make sure of customer satisfaction, check each lubrication point shown on the following pages. Lubricate with several strokes of John Deere Multi-Purpose Grease or equivalent, if necessary.

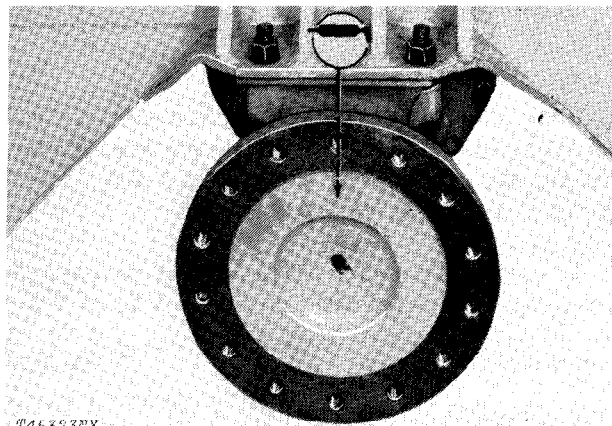

Fig. 14-Drive Axle Outer Bearing (2 points)

Lubrication required Yes No

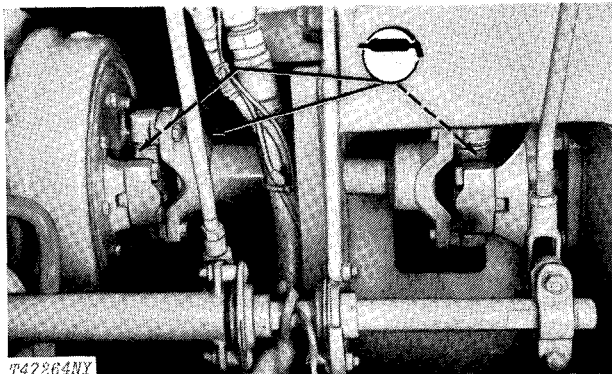

Fig. 15-Axle Drive Shaft Universal Joints (3 points)

Lubrication required Yes No



Fig. 16-Oscillation Hitch Pivots (4 points)

Lubrication required Yes No

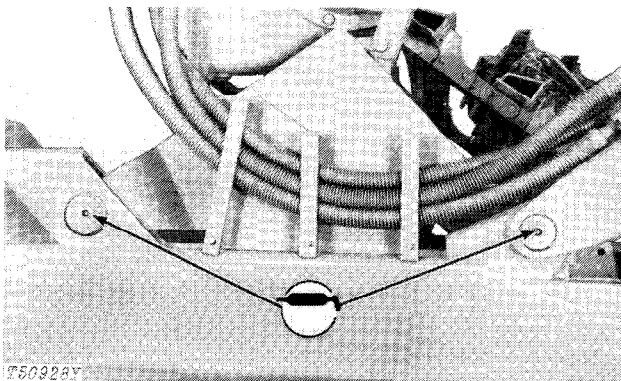

Fig. 17-Draft Frame and Elevator Pivots—  
 Right Side Shown (4 points)

Lubrication required Yes No

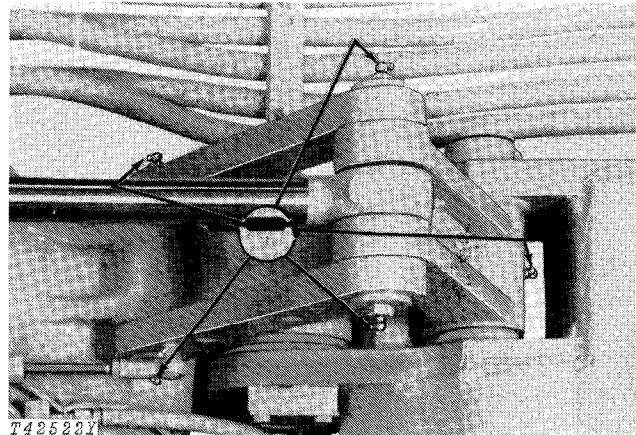

Fig. 18-Steering Links (10 points)

Lubrication required Yes No

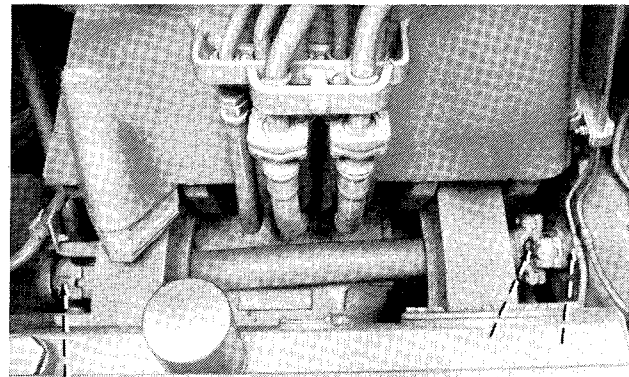
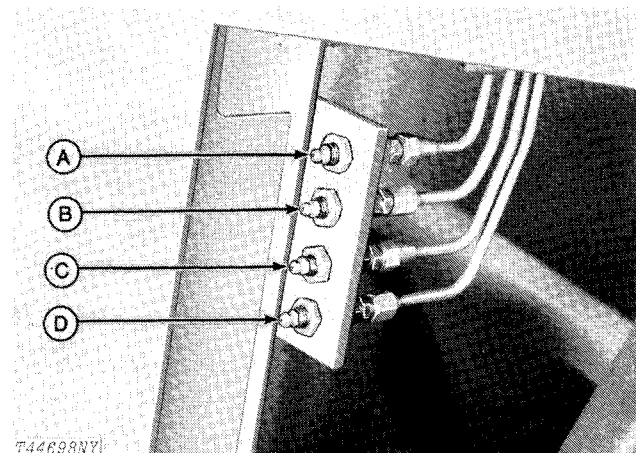

Fig. 19-Transmission Input Drive Shaft (3 points)

Lubrication required Yes No



A—Cylinder Pivot Lube      C—Left Pivot Lube  
 B—Lever Link Lube      D—Right Pivot Lube

Fig. 20-Central Lubrication System (4 points)

Lubrication required Yes No

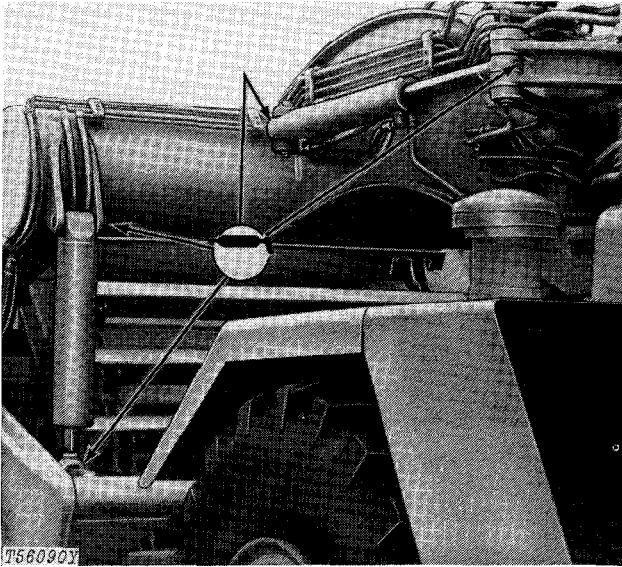

Fig. 21-Cylinder Pivots—One Side  
 (8 points)

Lubrication required Yes No

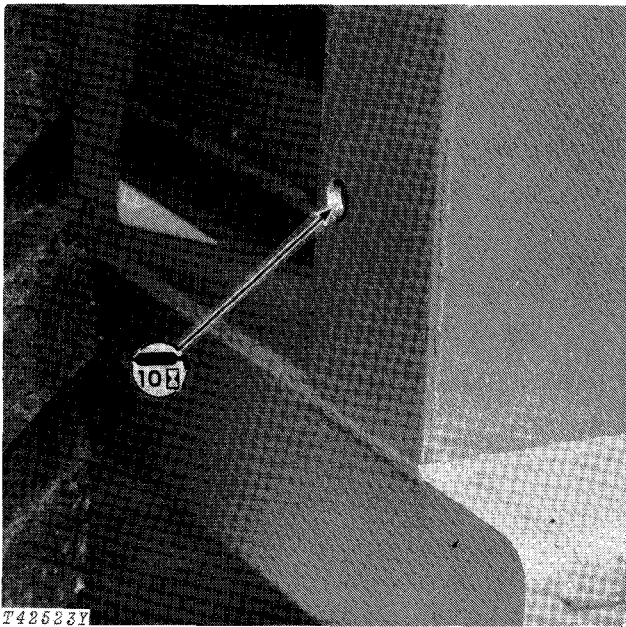

Fig. 22-Ejector Guide Rollers—Left Side  
 (2 points)

Lubrication required Yes No

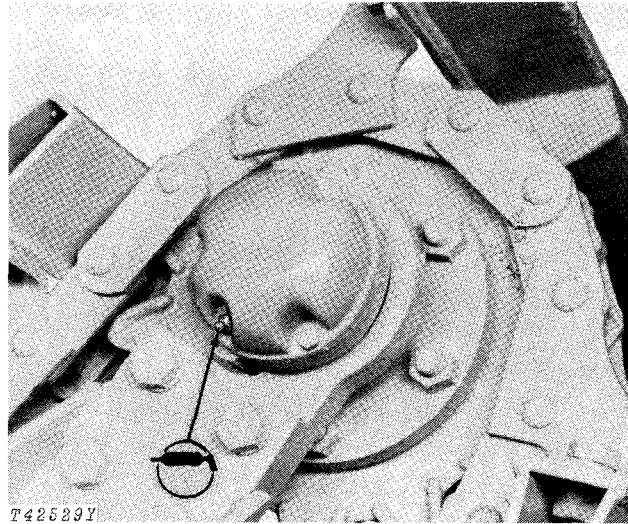

Fig. 23-Upper Elevator Cross-Shaft Bearing (1 point)

Lubrication required Yes No

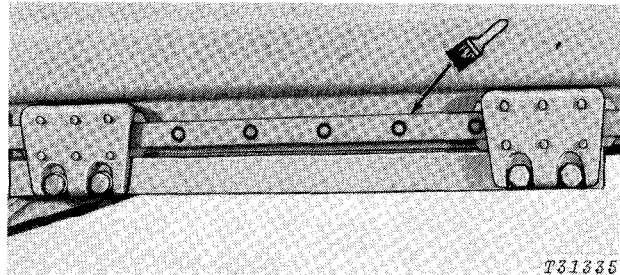

Fig. 24-Sliding Floor Side Rails

Use waste oil to lubricate the sliding floor side rails.

Sliding floor rails Yes No

### 16. Accessible Hardware Torque Values

Check all accessible bolts and nuts for correct tightness. If hardware is loose, tighten it to correct torque.

The table below gives correct torque values for various bolts and cap screws. Tighten all hardware to standard torque unless a different torque is specified.

Most hardware used is high-strength (note dashes on hex. heads). The types of bolts and cap screws are identified by head markings as follows:

3-Dash Head: tempered steel high-strength bolts and cap screws.

6-Dash Head: tempered steel extra high-strength bolts and cap screws.

Machine bolts and cap screws 7/8-inch (22 mm) and larger are sometimes formed hot rather than cold, which accounts for lower torque.

All accessible hardware torqued Yes No

Plain Head: regular machine bolts and cap screws.

RECOMMENDED TORQUE - COARSE AND FINE THREADS									
BOLT DIAMETER	PLAIN HEAD			THREE DASHES			SIX DASHES		
	LB-FT	Nm	Kg-m	LB-FT	Nm	Kg-m	LB-FT	Nm	Kg-m
1/4	NOT USED	NOT USED	NOT USED	10	14	1	14	19	2
5/16	NOT USED	NOT USED	NOT USED	20	27	3	30	41	4
3/8	NOT USED	NOT USED	NOT USED	35	47	5	50	68	7
7/16	35	47	5	55	75	8	80	108	11
1/2	55	75	8	85	115	12	120	163	17
9/16	75	102	10	130	176	18	175	237	24
5/8	105	142	15	170	230	24	240	325	33
3/4	185	251	26	300	407	42	425	576	59
7/8	160	217	22	445	603	62	685	929	95
1	250	339	35	670	908	93	1030	1396	142
1-1/8	330	447	46	910	1234	126	1460	1979	202
1-1/4	480	651	66	1250	1695	173	2060	2793	285

T43720

Fig. 25-Torque Chart

### 17. Fuel Tank

Fill the fuel tank with correct fuel.

Fuel tank filled Yes No

### 18. Seat

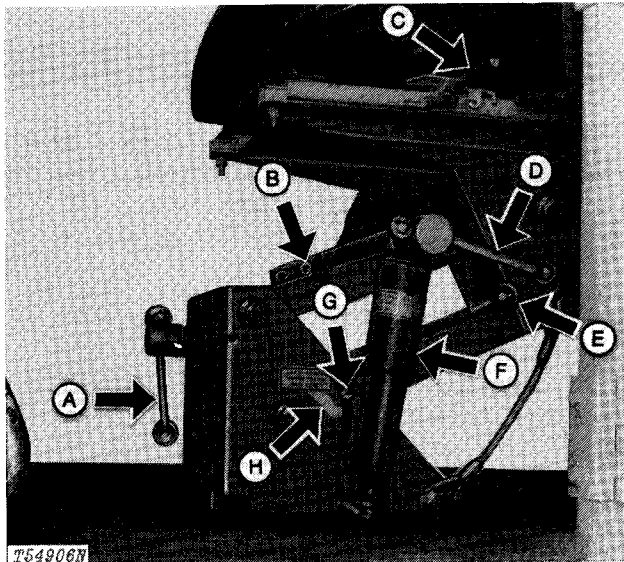

- |  |                  |
|--|------------------|
| A—Weight Adjustment Lever              | E—Up-Latch Lever |
| B—Cap Screw                            | F—Shock Absorber |
| C—Forward or Rearward Adjustment Lever | G—Pointer        |
| D—Ride Adjustment Lever                | H—Ride Zone      |

Fig. 26-Seat

Check the operation of levers and shock absorbers.

#### Adjustment for Weight

While seated, turn lever (A) clockwise to lower the seat. Turn the lever counterclockwise to raise the seat.

Change the height so pointer (G) is in the ride zone (H).

#### Adjustment Forward or Rearward

While seated, move lever (C) to the left (L.H.). Slide the seat to the desired position. Release the lever.

#### Adjustment for Ride

Right (R.H.) side: Install the shock absorber cap screw (B) in the front hole for a soft ride, or in the rear hole for a firm ride.

Left (L.H.) side: Loosen the lever (D). Slide the shock absorber forward for a soft ride or rearward for a firm ride. Tighten the lever.

Seat operation checked Yes No

### 19. Switches, Gauges, and Indicator Lights

Check the operation of the switches, gauges, and indicator lights.

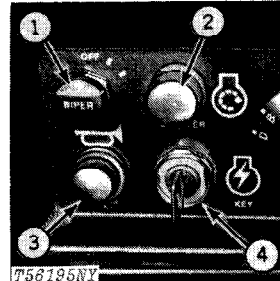

- |                  |                   |
|------------------|-------------------|
| 1—Wiper Switch   | 3—Horn Switch     |
| 2—Starter Switch | 4—Ignition Switch |

Fig. 27-Switch Panel

1 - Wiper Switch - Turn the switch clockwise for low or high speed.

2 - Starter Switch - Push the button to start the engine.

3 - Horn Switch - Push the button to sound dual horns.

4 - Ignition Switch - Turn the key clockwise to turn the switch on. No other switches or gauges work unless the ignition switch is on.

Switches checked Yes No

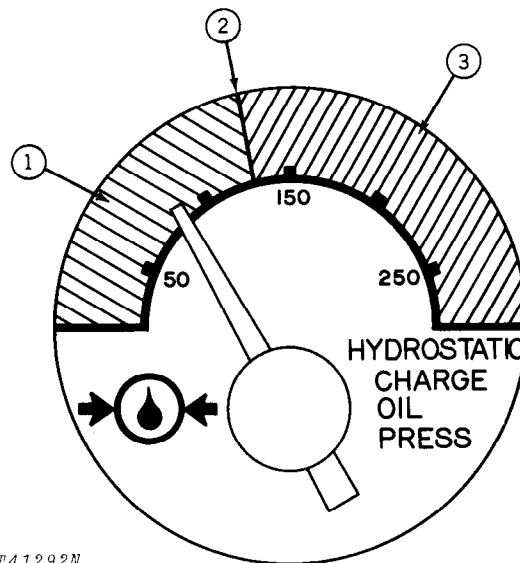

T41292N

- |                   |               |
|-------------------|---------------|
| 1—Red-Orange      | 3—Light Green |
| 2—130 psi (9 bar) |               |

Fig. 28-Hydrostatic Charge Oil Pressure Gauge

Light green zone (3) shows the normal operating range.

**NOTE:** If the gauge registers in the red-orange zone for a long time, the elevator drive filter could be plugged. Check the filter.

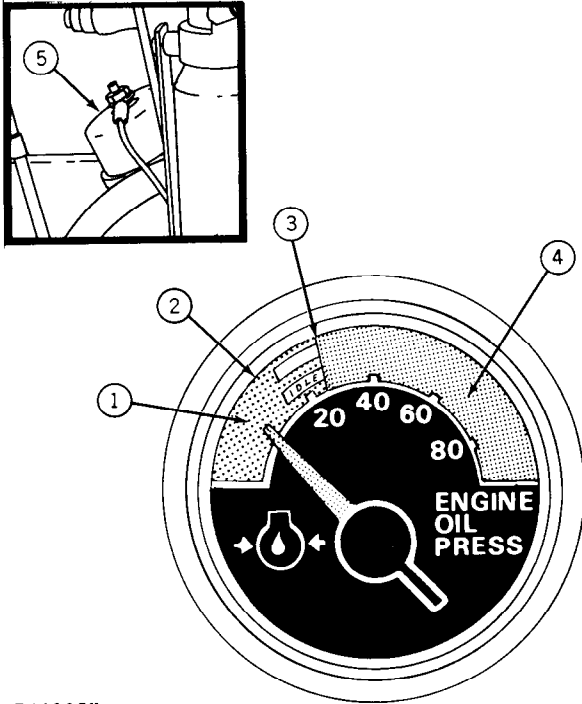

T41297N

- 1—Red-Orange
- 2—10 psi (70 kPa)
- 3—25 psi (170 kPa)
- 4—Light Green
- 5—Sending Unit

Fig. 29-Engine Oil Pressure Gauge

Normal operating range is 25-80 psi (170-550 kPa).

If the indicator hand goes into the red-orange zone, stop the scraper. Check the engine oil level. If the oil level is not low, check for restrictions in the oil lines or wrong viscosity oil.

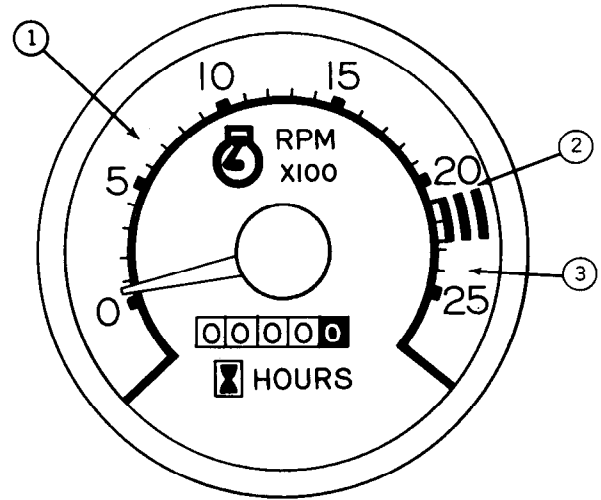

T41293N

- 1—Black
- 2—Light Green
- 3—Red

Fig. 30-Tachometer

Normal operating range is up to 2280 rpm (fast idle).

The hour meter shows hours and tenths of hours the engine has run.

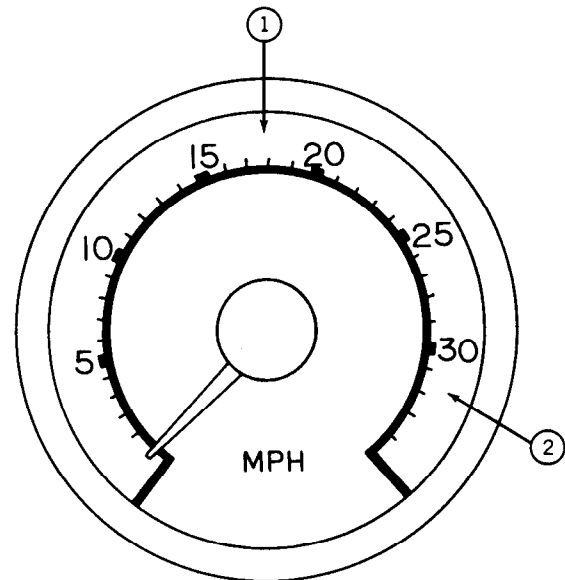

T41294N

- 1—Light Green
- 2—Red

Fig. 31-Speedometer

The speedometer shows scraper speeds from 0-34 mph (0.55 km/h).

**1**

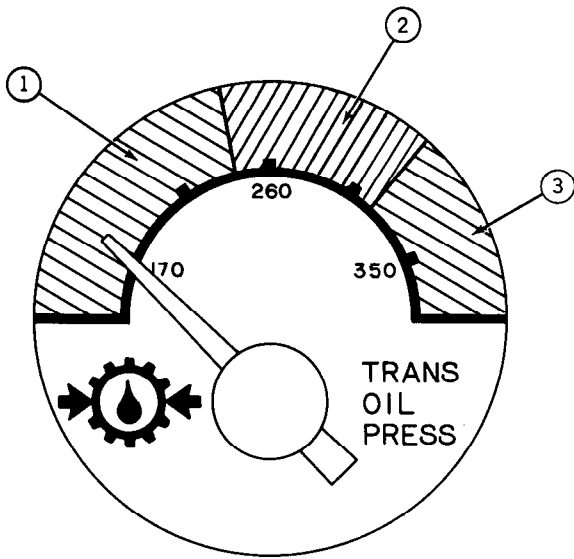

T50922

- 1—Red-Orange Zone
- 2—Light Green Zone
- 3—Red-Orange Zone

Fig. 32-Transmission Oil Pressure Gauge

The light green zone (2) shows the normal operating range.

**IMPORTANT:** If the indicator hand is in either red-orange zone, stop the scraper and find the cause.

*NOTE:* During cold weather, the gauge will normally read high for a short time after the engine starts.

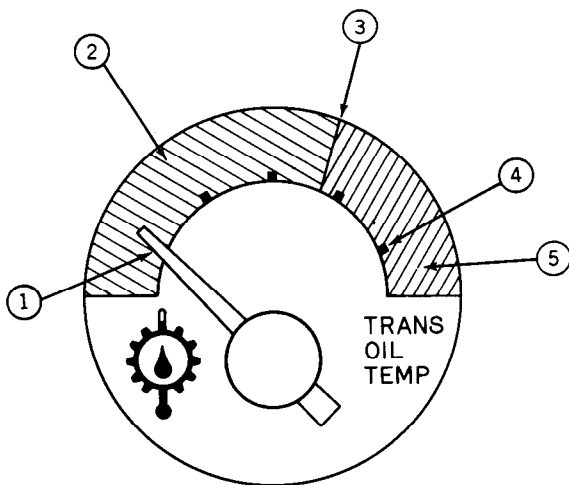

T41298N

- 1—100°F (38°C)
- 2—Light Green
- 3—250°F (121°C)
- 4—280°F (138°C)
- 5—Red

Fig. 33-Transmission Oil Temperature Gauge

The light green zone shows the normal operating range, 100-250°F (38-121°C).

If the indicator hand enters the red zone (5), operate in a lower gear or lockup. If the hand remains in the red zone, check the transmission oil level.

If these possible solutions do not lower the oil temperature, do not operate the scraper.

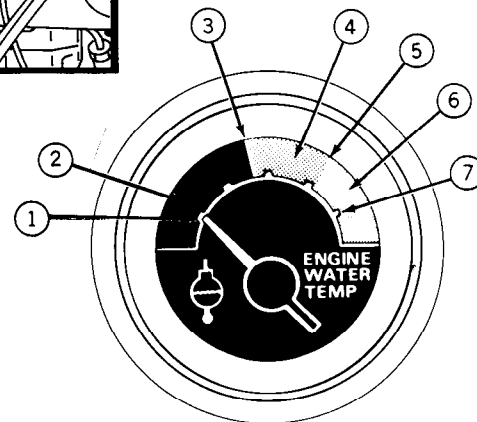
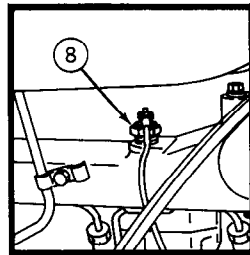

T41296N

- 1—100°F (38°C)
- 2—Black
- 3—160°F (71°C)
- 4—Light Green
- 5—224°F (107°C)
- 6—Red-Orange
- 7—280°F (138°C)
- 8—Sending Unit

Fig. 34-Engine Coolant Temperature Gauge

The light green zone (4) shows the normal operating temperatures, 160-224°F (71-107°C).

**IMPORTANT:** If the indicator hand goes into the RED-ORANGE ZONE, stop the engine and find the cause.

Gauges checked

Yes No

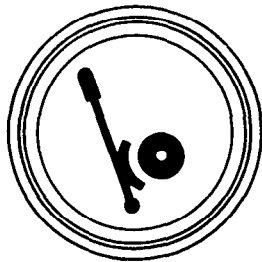

T41299N

Fig. 35-Parking Brake Indicator Light

This light will go on when the parking brake is engaged and the key switch is on.



T38471N

Fig. 36-Hydraulic Filter Restriction Indicator Light

This light will go on when hydraulic pressure drops more than 40 psi (270 kPa) at the filter. This shows a restriction in the filter.

**NOTE:** The light must be on when the key switch is in the start position and the engine off.

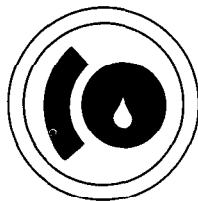

T38468N

Fig. 37-Brake Pressure Indicator Light

When the hydraulic brake pressure lowers, horns will sound at intervals, and the indicator light will go on.

This light will go on when pressure in the system is below 1050 psi (7200 kPa).

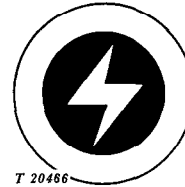

T 20466

Fig. 38-Alternator Indicator Light

This light will go on when the alternator is not charging.

Indicator lights checked Yes No

## 20. Lights

Check operation of the lights, light switches, and indicator lights.

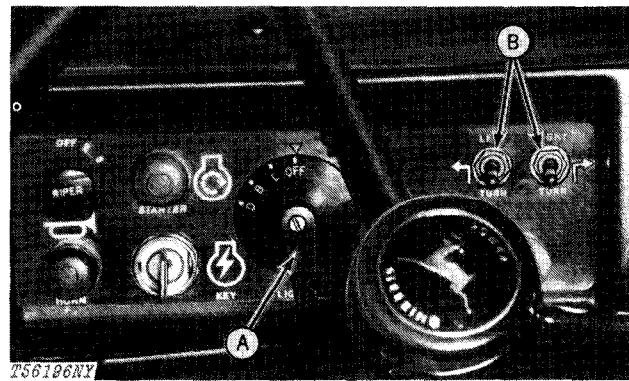

A—Light Switch

B—Turn Signal Switches

Fig. 39-Light Switches

### Light Switch

OFF - All lights off.

L - Two headlights, two floodlights, rear work light, front cab work light (if equipped), and red scraper taillights are on.

B - Two headlights, two floodlights, and the red scraper taillights are on.

D - Inner headlights are off. The outer floodlights and the red scraper taillights are on.

### Turn Signal Switches

Push the right (R.H.) or left (L.H.) toggle switch up to make the right (R.H.) or left (L.H.) turn signal flash. Push the switch down after a turn.

Push both switches up for four-way emergency flashing.

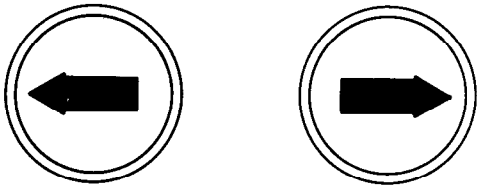

T38467N

Fig. 40-Turn Indicator Lights

The indicator light flashes along with the turn signal light.

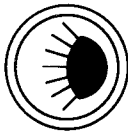

T38469N

Fig. 41-High Beam Indicator Light

The high beam indicator light is controlled by the light switch. When headlights are on, the indicator light will be blue.

Lights, light switches, and indicator lights checked Yes No

## 21. Air Conditioner

Check the air conditioner controls.

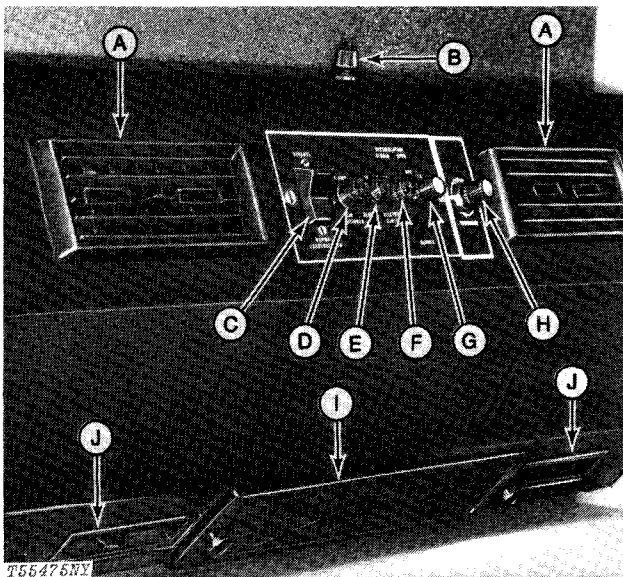

- A—Louvers
- B—Air Control Knob
- C—Condenser Fan Switch
- D—Air Conditioner Fuse
- E—Blower Fuse
- F—Electric Clutch Fuse
- G—Blower Control Knob
- H—Temperature Control Knob
- I—Recirculating Air Filter
- J—Louvers

Fig. 42-Air Conditioner Controls

**NOTE:** Air temperature must be 60°F (16°C) or higher.

1 - Turn the key switch ON. Operate the blower control knob (G) in all positions. Check the fan speeds and air volume from the louvers (A and J).

2 - Turn the key and blower switches ON. Turn the temperature control knob (H) clockwise toward maximum cooling. Listen for the click from compressor clutch.

3 - Turn the heater valve (on the engine) clockwise to closed position.

4 - Turn the blower control knob clockwise to high speed. Turn the temperature control knob clockwise to maximum cooling. Run the engine at approximately 2000 rpm.

5 - After ten minutes check the sight glass for bubbles. Remove the plug from the roof panel to check the sight glass on the receiver-dryer.

**NOTE:** Bubbles may be seen immediately after the compressor cycles ON. If bubbles are seen under any other condition, see Section 90, Group 9031.

6 - Check the temperature of air from the louvers. Hold a thermometer in louver until you get the lowest reading.

When air temperature is above 80°F (27°C), the temperature of air from the louvers must be 25°-30°F (14° - 17°C) lower.

When air temperature is below 80°F (27°C), the temperature of air from the louvers must be less than 50°F (10°C).

7 - When the unit does not operate correctly, see Section 90, Group 9031.

Air conditioner checked Yes No

## 22. Cab Equipment

Check the operation of the door, windows, heater, seat belts, tilt steering wheel, vandal cover, etc.

Cab equipment checked Yes No



**Suggest:**

**If the above button click is invalid.**

**Please download this document first, and then click the above link to download the complete manual.**

**Thank you so much for reading**

### 23. Test Drive

#### Transmission Oil Level

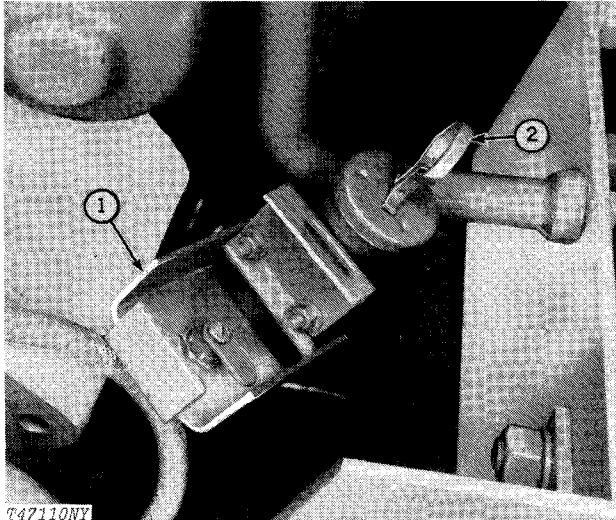

1—Transmission Dipstick Vandal Cover  
 2—Transmission Dipstick

Fig. 43-Transmission Oil Dipstick

Before starting the engine, check the oil level on the dipstick. If the oil level is at or near the upper (FULL) mark, there is enough oil in the system to start the engine. If the oil level is low, add oil specified on page I-IV-2. Install the dipstick.

#### Engine Speeds

Start the engine. Warm up the engine by operating at half-throttle for five minutes before moving the scraper. Do not run the engine at fast or slow idle.

Use the tachometer to check the engine speeds.

Slow idle must be 900 rpm. Fast idle must be 2300 rpm. If adjustment is needed, see page I-IV-38.

Engine speeds checked Yes No

#### Hydraulic System Cycle Times

*NOTE: Operate each hydraulic control until all air has been removed from the hydraulic system. Check all controls for freedom of movement and proper direction of travel before checking cycle times.*

Use the following times as a guide. If cycle times are much different than those listed, trouble shoot the hydraulic system. Check cycle times when the oil is warm and the engine at fast idle.

	Seconds
Elevator Speed (one complete revolution)	4.6 max.
Bowl Lift	3.8
Bowl Lower	3.6
Eject Cycle	9.7 max.
Steering (180° turn to right and left)	5.0 - 5.5 (Either Direction)
Return cycle (floor forward-gate rearward)	10.8

While checking cycle times, make a note of any equipment that is not working correctly.

When the engine is at slow idle (900 - 950 rpm), turn the steering wheel from stop to stop. Turn the steering wheel faster than normal to "force the turn". This will remove air from the steering system.

Air removed from steering system Yes No  
 Hydraulic cycle times checked Yes No  
 Any malfunctions, explain \_\_\_\_\_

\_\_\_\_\_

\_\_\_\_\_

**<https://www.ebooklibonline.com>**

Hello dear friend!

Thank you very much for reading.

Enter the link into your browser.

The full manual is available for immediate download.

**<https://www.ebooklibonline.com>**