

JOHN DEERE
WORLDWIDE COMMERCIAL & CONSUMER
EQUIPMENT DIVISION

Walk-Behind Snowblowers
724D

OPERATOR'S MANUAL



 **WARNING:** The Engine Exhaust from this product contains chemicals known to the State of California to cause cancer, birth defects or other reproductive harm.

California Proposition 65 Warning

OMM144062 F0

North American Version
Litho in U.S.A.

INTRODUCTION

Thank You for Purchasing a John Deere Product

We appreciate having you as a customer and wish you many years of safe and satisfied use of your machine.

Using Your Operator's Manual

This manual is an important part of your machine and should remain with the machine when you sell it.

Reading your operator's manual will help you and others avoid personal injury or damage to the machine. Information given in this manual will provide the operator with the safest and most effective use of the machine. Knowing how to operate this machine safely and correctly will allow you to train others who may operate this machine.

Sections in your operator's manual are placed in a specific order to help you understand all the safety messages and learn the controls so you can operate this machine safely. You can also use this manual to answer any specific operating or servicing questions. A convenient index located at the end of this book will help you to find needed information quickly.

The machine shown in this manual may differ slightly from your machine, but will be similar enough to help you understand our instructions.

RIGHT-HAND and LEFT-HAND sides are determined by facing in the direction the machine will travel when going forward. When you see a broken line arrow (----->), the item referred to is hidden from view.

Special Messages

Your manual contains special messages to bring attention to potential safety concerns, machine damage as well as helpful operating and servicing information. Please read all the highlighted information carefully to avoid injury and machine damage.

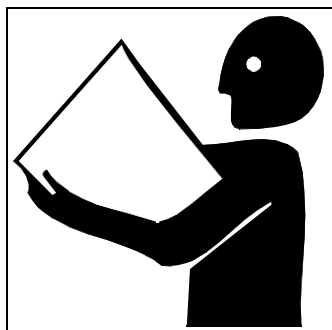

CAUTION: Avoid injury! This symbol and text highlight potential hazards or death to the operator or bystanders may occur if the hazards or procedures are ignored.

IMPORTANT: Avoid damage! This text is used to tell the operator of actions or conditions that might result in damage to the machine.

NOTE: General information is given throughout the manual that may help the operator in the operation of the machine.

PRODUCT IDENTIFICATION

Record Identification Numbers

Walk-Behind Snowblowers

724D PIN (200001 -)

If you need to contact an Authorized Service Center for information on servicing, always provide the product model and serial number.

You will need to locate the model and serial number for the machine and for the engine of your machine and record the information in the spaces provided below.

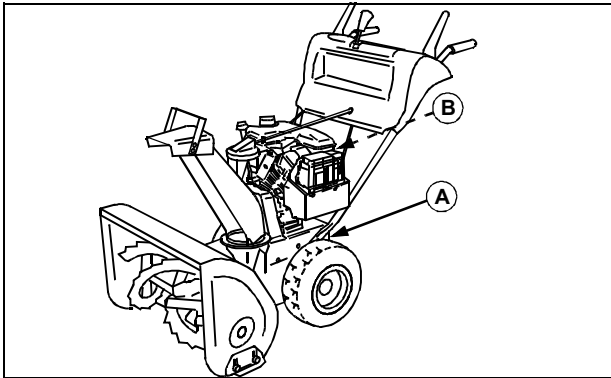

DATE OF PURCHASE:

DEALER NAME:

DEALER PHONE:

PRODUCT IDENTIFICATION NUMBER (A):

ENGINE SERIAL NUMBER (B):

<https://www.ebooklibonline.com>

Hello dear friend!

Thank you very much for reading.

Enter the link into your browser.

The full manual is available for immediate download.

<https://www.ebooklibonline.com>

TABLE OF CONTENTS

Safety	1
Operating	6
Replacement Parts	13
Service Intervals	14
Service	15
Troubleshooting	28
Storage	30
Assembly	32
Specifications	39
Warranty	40
Index	42

All information, illustrations and specifications in this manual are based on the latest information at the time of publication. The right is reserved to make changes at any time without notice.

COPYRIGHT© 2000
Deere & Co.

John Deere Worldwide Commercial and
Consumer Equipment Division
Horicon, WI

All rights reserved
Previous Editions
COPYRIGHT© 1998, 1997, 1996

OMM144062 F0 - English

SAFETY

Understanding The Machine Safety Labels

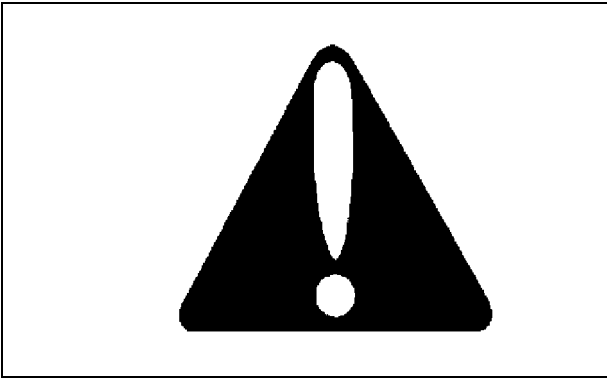

The machine safety labels shown in this section are placed in important areas on your machine to draw attention to potential safety hazards.

On your machine safety labels, the words DANGER, WARNING, and CAUTION are used with this safety-alert symbol, (▲). DANGER identifies the most serious hazards.

The operator's manual also explains any potential safety hazards whenever necessary in special safety messages that are identified with the word, CAUTION, and the safety-alert symbol, (▲).

DANGER:

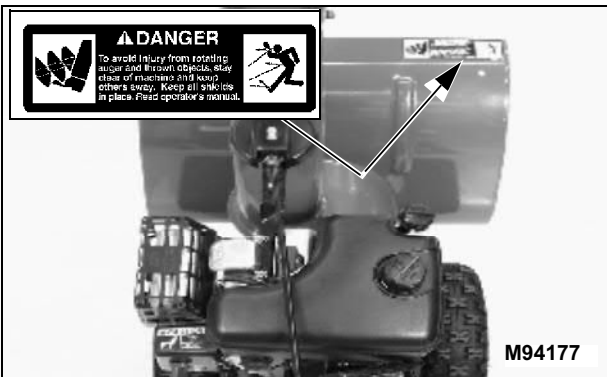

CAUTION:

To avoid injury from rotating auger and thrown objects, stay clear of machine and keep others away. Keep all shields in place. Read operator's manual.

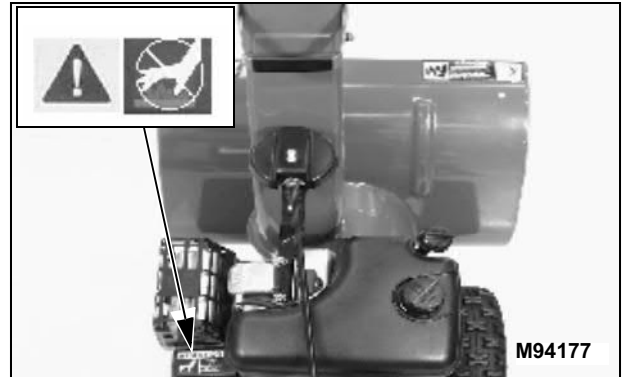

HOT

Muffler and Adjacent areas are HOT. Do Not Touch.

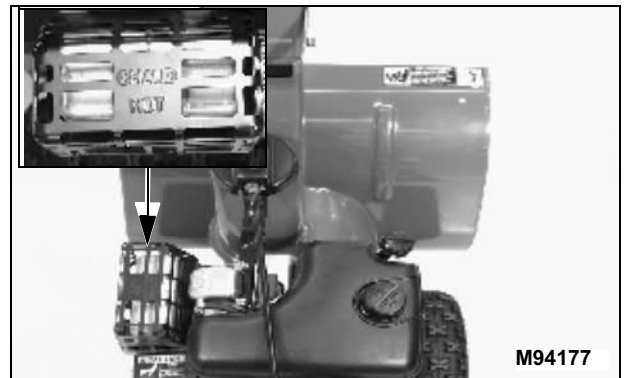

The word HOT is embossed in the muffler shield.

Certification Label

This OPEI label on your snow blower indicates that this model has been certified by an independent laboratory for compliance with American National Standard B-71.3, "Safety Specifications" for Snowblowers.

Emission Control System Certification Label

NOTE: Tampering with emission controls and components by unauthorized personnel may result in severe fines or penalties. Emission controls and components can only be adjusted by EPA and/or CARB authorized service centers. Contact your John Deere Commercial and Consumer Equipment Retailer concerning emission controls and component questions.

The presence of an emissions label signifies that the engine has been certified with the United States Environmental Protection Agency (EPA) and/or California

SAFETY

Air Resources Board (CARB).

The emissions warranty applies only to those engines marketed by John Deere that have been certified by the EPA and/or CARB; and used in the United States and Canada in off-road mobile equipment.

Emission Compliance Period

If your engine has the emission compliance category listed on the emission control system certification or air index label, this indicates the number of operating hours for which the engine has been certified to meet EPA and/or CARB emission requirements. The following table provides the engine compliance period in hours associated with the category found on the certification label.

Agency	Category	Hours
EPA	C	250
EPA	B	500
EPA	A	1000
CARB	Moderate	125
CARB	Intermediate	250
CARB	Extended	500

Operate Safely

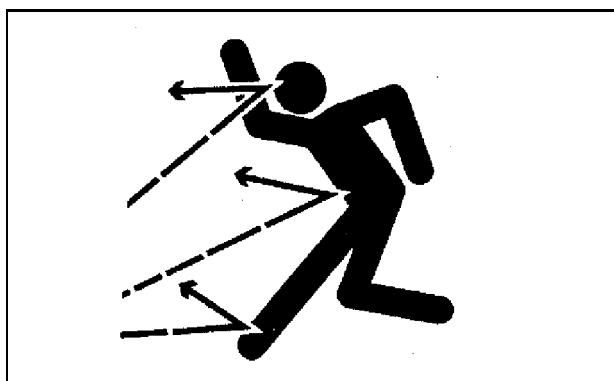

- Inspect machine before you operate. Be sure hardware is tight. Repair or replace damaged, badly worn, or missing parts. Be sure guards and shields are in good condition and fastened in place. Make any necessary adjustments before you operate.

- Clear work area of objects that might be thrown. Keep people and pets out of the work area. Stop machine if anyone enters the area.

- If you hit an object, stop the machine and inspect it. Make repairs before you operate. Keep machine properly maintained and in good working order. Keep all shields and guards in place.

- DO NOT blow snow toward people, cars, or buildings.

- DO NOT use snowblower on surfaces above ground level, such as, a roof of a building.

- Be extremely careful if you must clear snow from a gravel path. Be aware that snowblower may pick up gravel in snow. Adjust spout angle carefully to blow this snow safely.

- DO NOT leave machine unattended when it is running.

- Only operate during daylight or with good artificial light.

- Be sure of footing. Operate slowly on slippery surfaces. Be especially careful when you pull machine backwards with the engine running.

- DO NOT blow snow across a slope. Be careful when you change direction on a slope. Do not try to clear snow from steep slopes. Keep away from edge of a ditch or bank.

- Keep a firm hold on the machine handles. Avoid sudden starts and stops.

- DO NOT run engine in a building unless there is good ventilation.

Rotating Blades Are Dangerous - Protect Children And Prevent Accidents

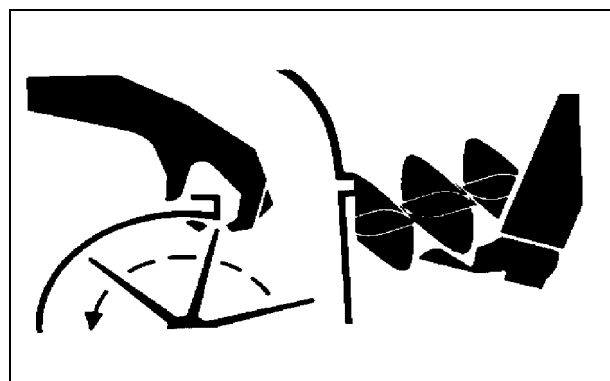

Protect Children:

- Never assume that children will remain where you last saw them. Children are attracted to blowing snow, stay alert to the presence of children.

- Keep children in the house when you are operating the machine.

- Turn machine off if a child enters the area.

- Use extra care when you come to blind corners, shrubs, trees, or other objects that may block your vision.

SAFETY

- Do not let children or an untrained person operate the machine.

Help Prevent Serious Or Fatal Accidents:

- Be alert at all times, people especially children can move quickly into the area before you know it.
- Shut off auger when you are not blowing snow.
- Keep hands, feet, and clothing away from moving parts.

Practice Safe Maintenance



- Understand service procedure before doing work. Keep area clean and dry.
- Never lubricate or service snowblower while it is moving. Keep safety devices in place and in working condition. Keep hardware tight.
- To prevent them from getting caught, keep hands, feet, clothing, jewelry, and long hair away from any moving parts.
- Before servicing snowblower, disengage all power and stop the engine. Let engine cool.
- Securely support any machine elements that must be raised for service work.
- Keep all parts in good condition and properly installed. Fix damage immediately. Replace worn or broken parts. Remove any buildup of grease, oil, or debris.
- Unauthorized modifications to the snowblower may impair its function and safety.

Wear Appropriate Clothing

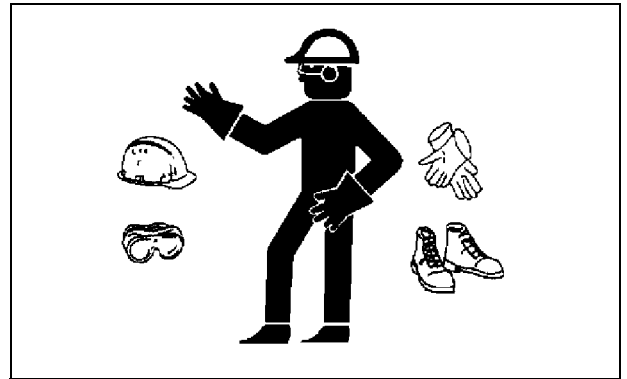

- Wear close fitting clothing and safety equipment appropriate for the job.
- Wear eye protection.
- Loud noise can cause impairment or loss of hearing, wear a suitable protective device such as earplugs.
- Do not wear radio or music headphones while servicing the machine. Safe service requires your full attention.

Avoid Injury From Moving Parts

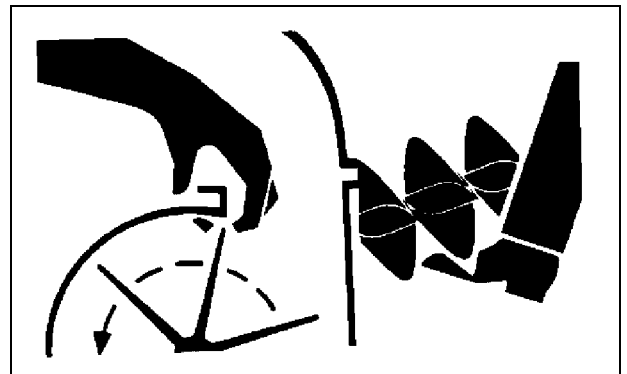

- Keep hands, feet and clothing away from snowblower and discharge chute when auger is turning.
- Stop auger when you are not blowing snow.
- Stop vehicle engine before you unplug, repair, or adjust snowblower.

SAFETY

Tire Safety

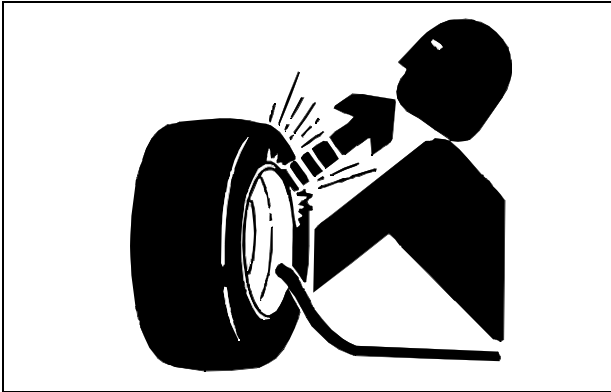

Explosive separation of a tire and rim parts can cause serious injury or death:

- Do not attempt to mount a tire without the proper equipment and experience to perform the job.
- Always maintain the correct tire pressure. Do not inflate the tires above the recommended pressure. Never weld or heat a wheel and tire assembly. The heat can cause an increase in air pressure resulting in a tire explosion. Welding can structurally weaken or deform the wheel.
- When inflating tires, use a clip-on chuck and extension hose long enough to allow you to stand to one side and not in front of or over the tire assembly.
- Check tires for low pressure, cuts, bubbles, damaged rims or missing lug bolts and nuts.

Handling Fuel Safely

Fuel and fuel vapors are highly flammable:

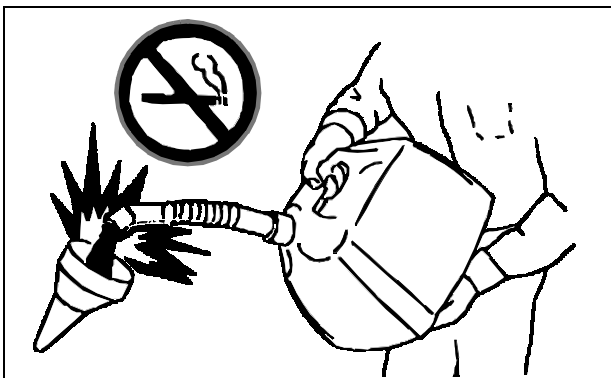

- Do not refuel machine while you smoke, when machine is near an open flame or sparks, or when engine is running. Stop engine.
- Fill fuel tank outdoors.
- Prevent fires: clean oil, grease and dirt from machine.

Clean up spilled fuel immediately.

- Do not store machine with fuel in tank in a building where fumes may reach an open flame or spark.
- Prevent fire and explosion caused by static electric discharge. Use only non-metal, portable fuel containers approved by the Underwriter's Laboratory (U.L.) or the American Society for Testing & Materials (ASTM). If using a funnel, make sure it is plastic and has no screen or filter.
- Static electric discharge can ignite gasoline vapors in an ungrounded fuel container. Remove the fuel container from the bed of a vehicle or the trunk of a car and place on the ground away from the vehicle before filling. Keep nozzle in contact with container opening while filling.

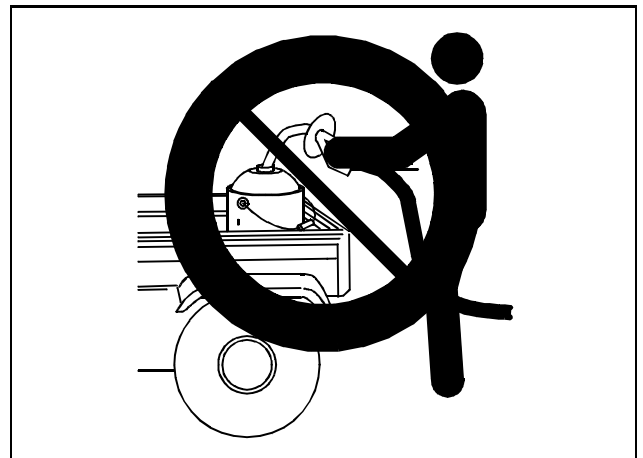

- When practical, remove equipment from trailers or truck beds and refuel them on the ground. If this is not possible, use a portable, plastic fuel container to refuel equipment on a truck bed or trailer.
- Do not use methanol gasoline. Methanol is harmful to the environment and to your health.

Handling Waste Products

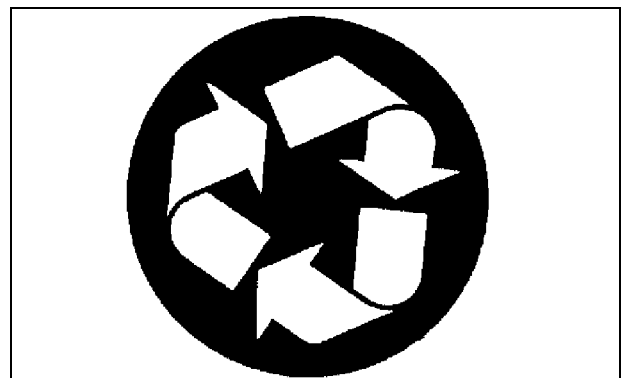

- Waste products, such as, used oil, fuel, and batteries, can harm the environment and people.

SAFETY

- Do not use beverage containers for waste fluids - someone may drink from them.
- See your local Recycling Center or John Deere dealer to learn how to recycle or get rid of waste products.
- A Material Safety Data Sheet (MSDS) provides specific details on chemical products: physical and health hazards, safety procedures, and emergency response techniques. See your John Deere dealer for the MSDS on chemical products used with your machine.

OPERATING

Daily Operating Checklist

- Check fuel level.
- Check engine oil level.
- Check hardware.
- Inspect snowblower.

Avoid Damage to Plastic and Painted Surfaces

- Do not wipe plastic parts unless rinsed first.
- Be careful not to spill fuel on machine. Fuel may damage surface. Wipe up spilled fuel immediately.

Engine Controls

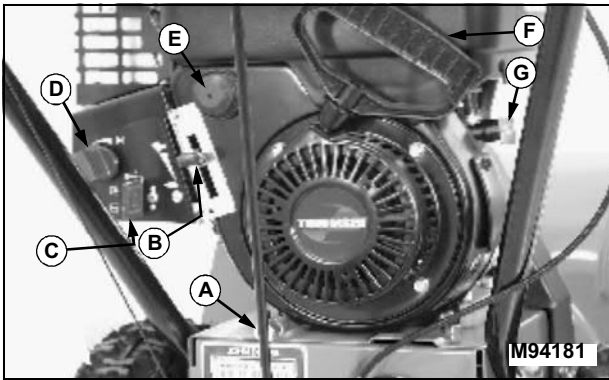

- A - Engine Oil Drain Plug**
- B - Throttle Lever**
- C - Engine Ignition Key**
- D - Choke Knob**
- E - Primer Bulb**
- F - Starter Handle**
- G - Fuel Shut Off Knob**

Console Controls

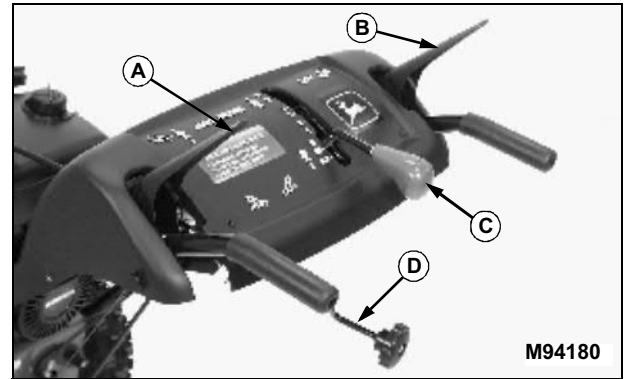

- A - Traction Drive Lever**
- B - Auger Drive Lever**
- C - Speed Selector Lever**
- D - Discharge Chute Control**

Adjusting Scraper Blade

IMPORTANT: Avoid damage! If scraper blade wears too far auger/impeller housing may be damaged.

1. Park snowblower on a hard, smooth surface.
2. Stop engine, remove key, wait for all moving parts to stop.
3. Remove wire from spark plug to prevent accidental starting.
4. Tip unit back onto handle bars and support housing.
5. Adjust skid shoes to their full up position.

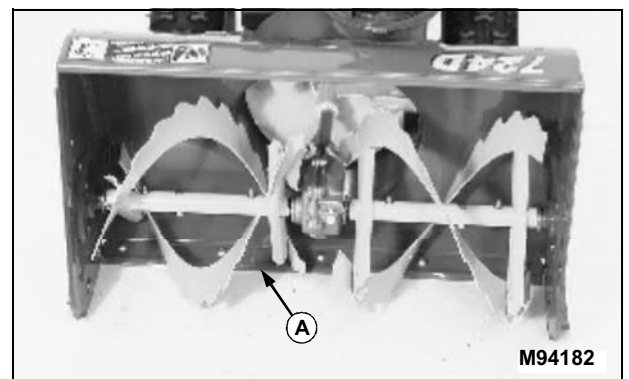

6. Inspect scraper blade (A):
 - If scraper blade has excessive wear, replace it.
 - If scraper blade can be adjusted; loosen nuts and reposition scraper blade, flush with skid shoes.
7. Tighten nuts.

OPERATING

8. Adjust skid shoes to the proper height.

Adjusting Skid Shoes

Adjust skid shoe height for proper working conditions:

- To operate on a smooth, hard surface: Adjust skid shoes so there is 3mm (1/8 in.) between scraper blade and surface.
- To operate on gravel or uneven surface: Adjust skid shoes so there is 30mm (1-1/4 in.) between scraper blade and surface.
- To operate on hard packed snow: Remove skid shoes and install them upside down. This will prevent the snowblower from riding up on the snow. Adjust skid shoes so there is 3mm (1/8 in.) between scraper blade and surface.

1. Park snowblower on a hard, smooth surface.
2. Stop engine, remove key, wait for all moving parts to stop.
3. Remove wire from spark plug to prevent accidental starting.
4. Check tires:
 - Air pressure in both tires should be equal, although some machine leveling can be made by using different pressures. Check for a maximum of 165 kPa (24 psi) in each tire.
 - Each tire must be resting on hard surface, not a cross-link of tire chain.
5. Put a block under auger housing.

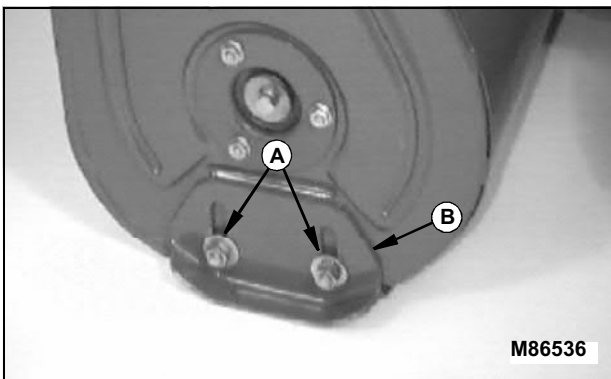

6. Inspect skid shoes:
 - If skid shoes have excessive wear, replace them.
 - If skid shoes can be adjusted; loosen two nuts (A) and move skid shoe (B) to desired position.
7. Tighten nuts. Adjust other skid shoe to the same height.

Using Drive Control Levers

Traction Drive Lever (A):

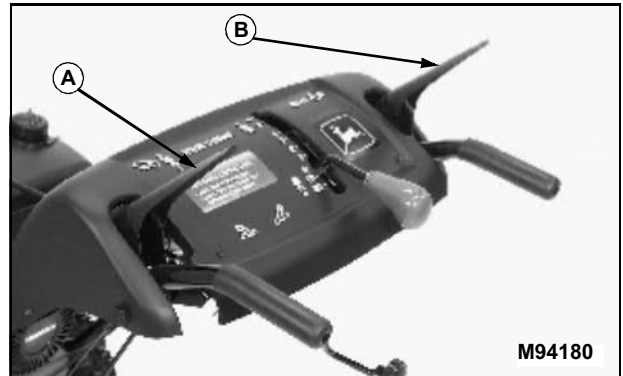

- Pull lever (A) to handle to engage the traction drive.
- Release lever to disengage traction drive.
- Traction drive lever (A) works independently from the auger drive lever (B).
- If unit does not respond, is slow to respond or engages too aggressively when the traction drive lever is engaged, adjust traction drive clutch.

Auger Drive Lever (B):

- Pull lever (B) to handle to engage the auger drive.
- Release lever to disengage auger drive.
- Auger drive lever (B) works independently from the traction drive lever (A).
- If auger is not throwing snow very well or it feels like the auger drive belt is slipping when the auger drive lever is engaged, adjust auger drive belt tension.
- If the auger does not come to a complete STOP in 5 seconds or less after the auger drive lever is released, adjust impeller / auger brake.

Using Speed Selector Lever

IMPORTANT: Avoid damage! DO NOT overload machine capacity by attempting to clear snow at too fast a rate.

OPERATING

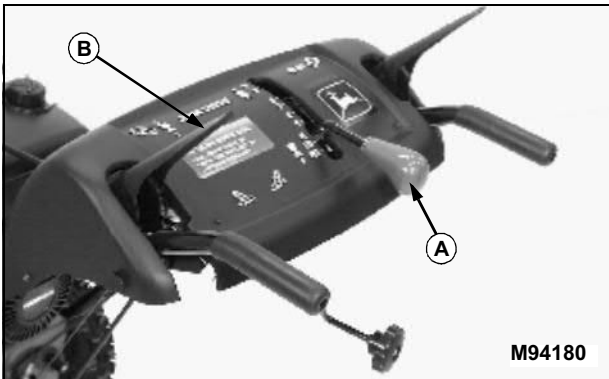

- The speed selector lever (A) controls the units forward speed and reverse motion.
- Moving the speed selector lever forward increases forward travel. There are six forward speeds available: "1" is the slowest speed and "6" is the fastest speed.
- Moving the speed selector lever rearward increases reverse travel. There are two reverse speeds available: "R1" is the slowest speed and "R2" is the fastest speed.

To Operate Speed Selector Lever:

- With engine running, position speed selector lever in the notch of the desired speed and ENGAGE the traction drive lever (B).
- Forward speed can be changed without decollating (releasing traction drive lever).
- DO NOT change motion from forward to reverse with traction drive lever ENGAGED.
- Release traction drive lever to STOP forward or reverse travel.
- Drive wheel slippage will occur as the traction drive wheel wears.

Using Discharge Chute Controls



CAUTION: Avoid injury!

- DO NOT put hands or feet near or under rotating parts.
- Keep clear of discharge opening at all times.
- DO NOT use hands to unclog chute.

DISCHARGE CHUTE

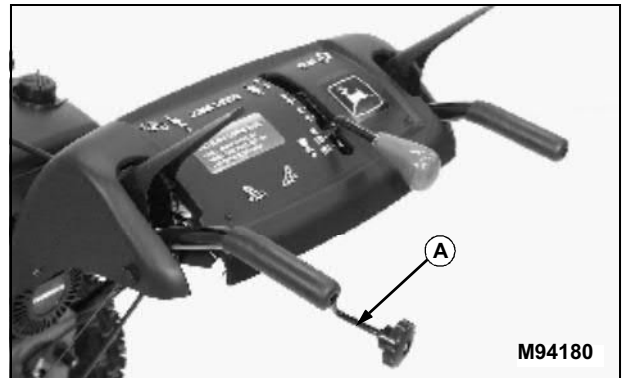

- The discharge chute control (A) will rotate the discharge chute (B).
- The discharge chute will rotate (full right, straight ahead, or full left).
- If discharge chute is too difficult to rotate or is too loose.

Chute Deflector

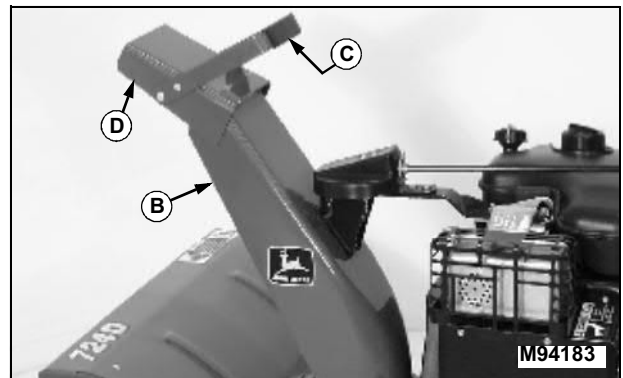

- The chute deflector lever (C) will assist in positioning the chute deflector (D):
- The chute deflector will determine how high or low snow will be thrown.
- If the chute deflector becomes difficult to move or is too loose.

Pre-Starting Engine

IMPORTANT: Avoid damage! In very cold weather, check impeller to be sure it is not frozen. Starting with a frozen impeller could damage the unit.

OPERATING

To check unit for a frozen impeller (A):

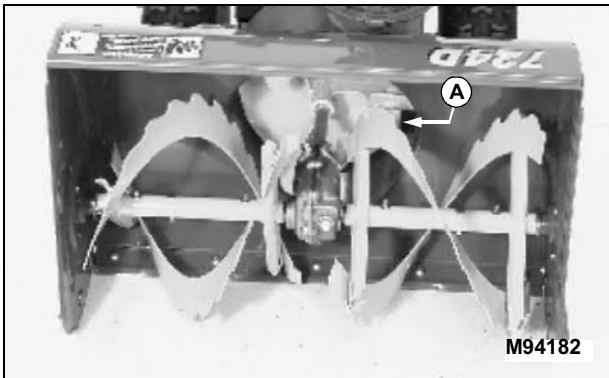

1. Disconnect spark plug wire from spark plug.
2. Engage auger drive lever.
3. Pull engine rewind starter.

If impeller is frozen: Rewind starter can not be pulled. Move unit to a heated area so ice around impeller can thaw.

If Impeller is not frozen: Rewind starter can be pulled – it will be more difficult than normal.

Starting Engine



CAUTION: Avoid injury! DO NOT start engine in building unless ventilation is good.

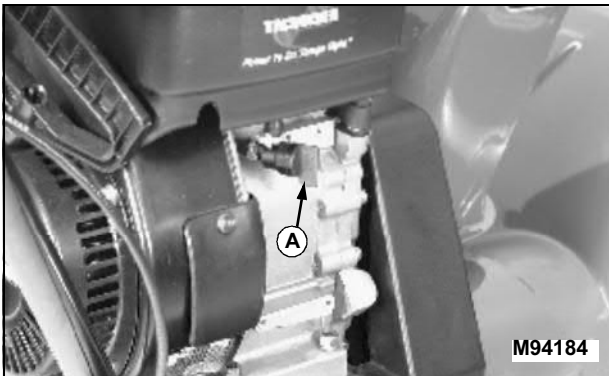

1. Check fuel shut off valve (A). Valve must be in the full open position.

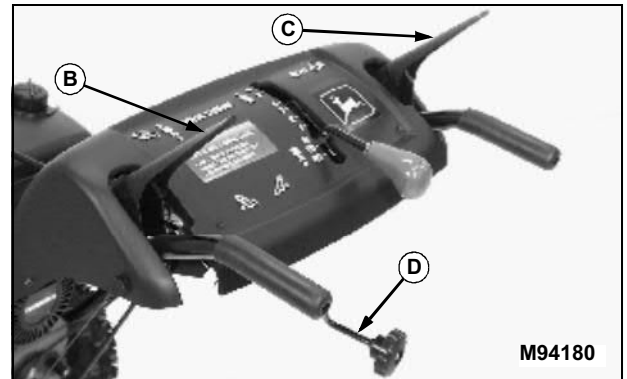

2. Traction drive lever (B) and auger drive lever (C) must be in the DISENGAGED position.
3. Speed selector lever (D) should be in the "N" NEUTRAL position.

NOTE: The engine ignition key is a two position PUSH/PULL design. DO NOT twist key after it is installed.

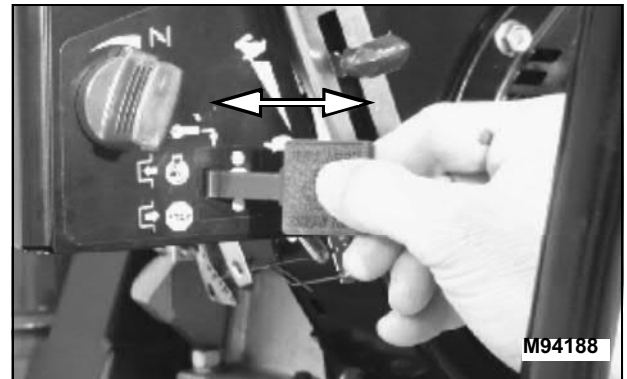

4. Install engine ignition key and PUSH it into the "ON" position.
 - "ON" position. To enable the ignition system, push key all the way in until you feel it "Click" into place.
 - "STOP" position. To disable the ignition system, pull key all the way out.

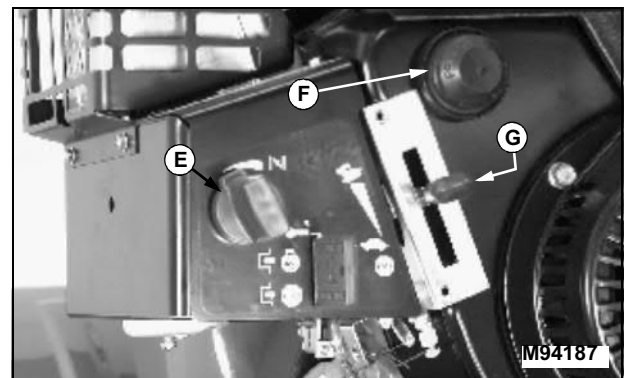

5. Turn choke control knob (E) to choke engine. This engine is equipped with a three position choke:



Suggest:

If the above button click is invalid.

Please download this document

first, and then click the above link

to download the complete manual.

Thank you so much for reading

OPERATING

- Cold engine: Turn choke knob clockwise to the full "N" position.
 - Warm / Hot engine: Turn choke knob to the off position or the middle position, depending on engine temperature.
6. Push primer bulb (F) to force fuel into the carburetor, be sure to cover vent hole in primer bulb:
- Cold engine: Push primer bulb quickly two or three times. When temperatures go below -10° C (15° F) repeat priming may be needed.
 - Warm / Hot engine: Push primer bulb once or not at all depending on engine temperature.
7. Move throttle lever (G) to set engine speed:
- Cold engine: Set throttle lever at 1/2 to 3/4 fast "🐔" position.
 - Warm / Hot engine: Set throttle lever in the slow "🐢" position.
8. Start engine:

Manual Start – Standard Equipment

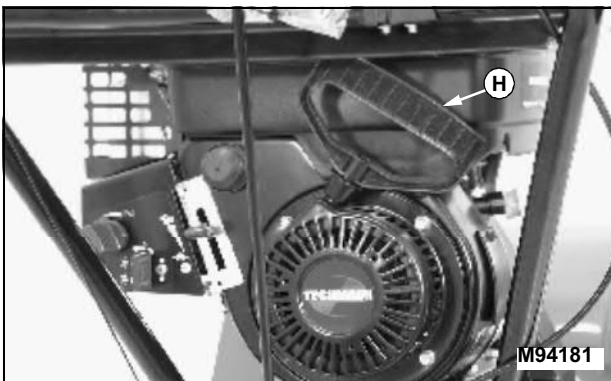

- a. Pull starter handle (H) until you feel resistance within the engine.
 - b. Then pull handle fast and steady.
 - c. Do not let handle snap back.
 - d. Repeat steps 6 and 8 until engine starts.
- If starter handle is frozen and will not crank engine:
- a. Pull as much rope out of starter as possible.
 - b. Release starter handle and let it snap back against starter, repeat as required.



CAUTION: Avoid injury! If your house wiring system is not a three-wire grounded system, DO NOT connect the electric starter to it under any condition. Use only a grounded (three-prong) cord to connect switch box to electrical power.

- Connect cord to switch box **FIRST**, then to electrical power.

Electric Start – Optional Equipment

IMPORTANT: Avoid damage! The house circuit you use should be protected by a 20 amp fuse.

- A smaller fuse may burn out when you use the electric starter.
- A larger fuse may burn out the snowblower starter motor.

NOTE: The electric starter motor will shut off automatically if it overheats from cranking the engine. After the motor cools, it will operate again.

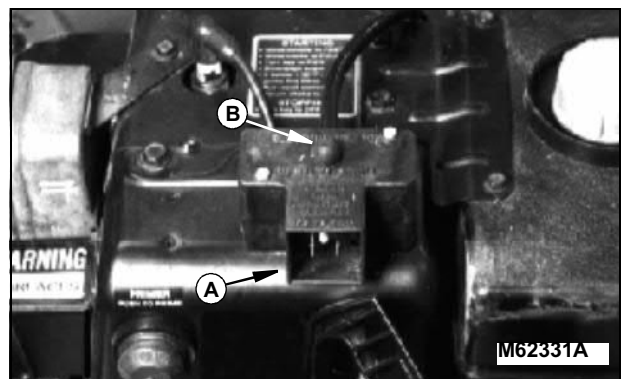

1. Connect power cord to engine switch box (A).
2. Plug other end of cord into three-hole, grounded 120-volt AC. receptacle.
3. Push starter button (B) to start engine.
4. Disconnect cord from house circuit first. Then disconnect cord from switch box.
5. With engine started:
 - Slowly move choke knob to the off position.
 - Slowly move throttle lever to desired engine speed.

Stopping Engine

Follow steps below before you park, inspect, adjust, or unplug snowblower.

<https://www.ebooklibonline.com>

Hello dear friend!

Thank you very much for reading.

Enter the link into your browser.

The full manual is available for immediate download.

<https://www.ebooklibonline.com>