

Technical Manual

John Deere 690B Excavator

**John Deere Davenport Works
TM-1093 (Feb-82)**



Litho in U.S.A.

JD690-B EXCAVATOR

Technical Manual
TM-1093 (Feb-82)

CONTENTS

- Section 10 - GENERAL
 - Group 5 Specifications
 - Group 10 Predelivery, Delivery, and After-Sale Services
 - Group 15 Lubrication
- Section 20 - ENGINE
 - Group 5 Engine Removal and Installation
 - Group 10 Basic Engine
 - Group 15 Engine Lubrication System
 - Group 20 Engine Cooling System
 - Group 25 Fuel System
 - Group 30 Speed Control Linkage
 - Group 35 Air Intake System
 - Group 40 Specifications and Special Tools
- Section 30 - ELECTRICAL SYSTEM
 - Group 5 Batteries
 - Group 10 Charging System
 - Group 15 Starting System
 - Group 20 Gauges and Switches
 - Group 21 Heating and Air Conditioning
 - Group 25 Specifications and Special Tools
- Section 40 - POWER TRAIN
 - Group 5 Undercarriage
 - Group 10 Track Drive
 - Group 15 Swing Drive
 - Group 20 Specifications and Special Tools
- Section 50 - HYDRAULIC SYSTEM
 - Group 5 Main Hydraulic Pump
 - Group 10 Hydraulic Motors
 - Group 15 Control Valve and Linkage
 - Group 16 Pilot Controls
 - Group 20 Flow Divider Valves
 - Group 25 Rotary Manifold
 - Group 30 Counterbalance Valve
 - Group 35 Crossover Relief and Solenoid Valves
 - Group 40 Reservoir, Oil Cooler, and Filters
 - Group 45 Cylinders
 - Group 50 Specifications and Special Tools
- Section 60 - MISCELLANEOUS COMPONENTS
 - Group 5 Tracks and Track Rollers
 - Group 10 Main Frame
 - Group 15 Boom and Buckets
 - Group 20 Counterweight and Rear Bumper
 - Group 25 Cab
 - Group 30 Specifications and Special Tools
- Section 70 - SYSTEM TESTING
 - Group 5 General Information
 - Group 10 Engine
 - Group 15 Electrical System
 - Group 16 Heating and Air Conditioning
 - Group 20 Power Train
 - Group 25 Hydraulic System
 - Group 26 Hydraulic System (Analyzer)
 - Group 30 Miscellaneous Components
 - Group 35 Specifications and Special Tools

INDEX

The specifications and design information contained in this manual were correct at the time it was printed. It is John Deere's policy to continually improve and update our machines. Therefore, the specifications and design information are subject to change without notice. Wherever applicable, specifications and design information are in accordance with SAE and IEMC standards.

Copyright © 1982
DEERE & COMPANY
Moline, Illinois

All rights reserved
Previous Editions

Copyright © 1981 Deere & Company
Copyright © 1979 Deere & Company
Copyright © 1977 Deere & Company
Copyright © 1976 Deere & Company
Copyright © 1975 Deere & Company
Copyright © 1974 Deere & Company
Copyright © 1973 Deere & Company

OOA

INTRODUCTION

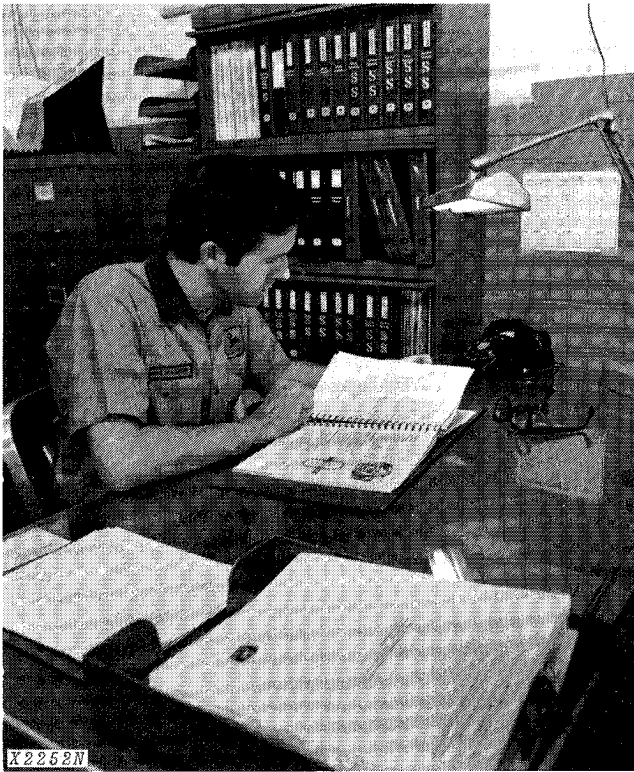

Use FOS Manuals for Reference



Use Technical Manuals for Actual Service

This technical manual is part of a twin concept of service:

The two kinds of manuals work as a team to give you both the general background and technical details of shop service.

•FOS Manuals—for reference

Fundamentals of Service (FOS) Manuals cover basic theory of operation, fundamentals of trouble shooting, general maintenance, and basic types of failure and their causes. FOS Manuals are for training new personnel and for reference by experienced service technicians.



When a service technician should refer to a FOS Manual for more information, a FOS symbol like the one at the left is used in the technical manual.

•Technical Manuals—for actual service

Technical Manuals are concise service guides for specific machines. Technical manuals are on-the-job guides containing only the vital information needed by an experienced service technician.

This technical manual was written for you—an experienced service technician. Keep it in a permanent binder in the shop where it is handy. Read it when you need to know correct service procedures or specifications.

Some features of this manual:

- Inside front cover - "Table of Contents" and "Maintenance Without Accident".
- Section 10 - General specifications and services.
- Sections 20 through 60 - Removal, repair, testing (components removed), installation, and adjustment.
- Section 70 - Detailed explanation of system operation, diagnosis, visual inspection, testing, and adjustments.
- Specifications are listed and illustrated at the end of each section.

<https://www.ebooklibonline.com>

Hello dear friend!

Thank you very much for reading.

Enter the link into your browser.

The full manual is available for immediate download.

<https://www.ebooklibonline.com>

MAINTENANCE WITHOUT ACCIDENT WORK SAFELY



T27999N

I27999N

 This safety symbol is used for important safety messages. When you see this symbol, follow the safety message to avoid personal injury.

EVERY EMPLOYER HAS A SAFETY PROGRAM. KNOW WHAT IT IS!

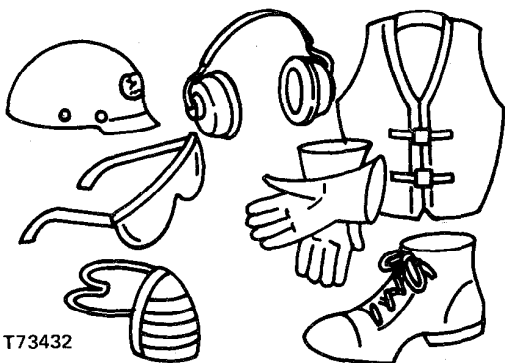

T73432

T73432

See your shop supervisor for specific instructions on a job, and the safety equipment you may need.

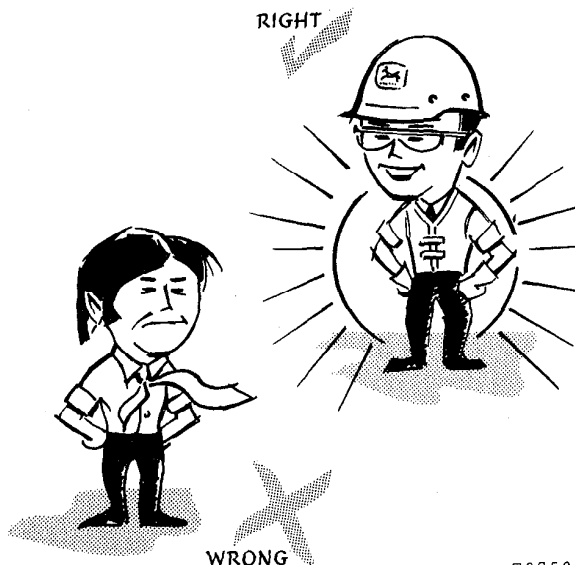

RIGHT

WRONG

T27502N
T27502N

BE ALERT!

Plan ahead — work safely — know how to use a first aid kit and a fire extinguisher — and where to get assistance.

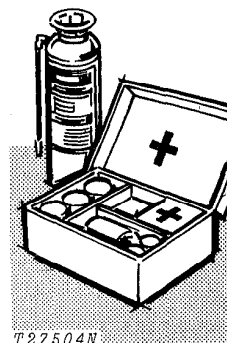

T27504N

T27504N

Maintenance Area

Make sure the maintenance area has enough ventilation.

Keep the maintenance area **CLEAN AND DRY**. Oily and wet floors are slippery. Greasy rags are a fire hazard. When you work with electrical equipment, wet spots are dangerous.

Keep starting aids in a cool, well-ventilated place, out of reach of unauthorized personnel.

MAINTENANCE WITHOUT ACCIDENT

AVOID FIRE HAZARDS -

Fuel Is Dangerous!



Do not smoke while you fill the fuel tank.

Do not smoke while working with material that will start on fire easily.

Stop the engine before you fill the fuel tank.

If the engine is hot, use care when you fill the fuel tank.

Do not use gasoline or diesel fuel for cleaning parts. Use solvents that will not start on fire.

Battery Gas is Highly Flammable!



Do not check the battery charge by putting metal objects across the posts.

Keep sparks and flames away from batteries.

Do not smoke near battery.

Flame Is Not a Flashlight!

DO NOT USE OPEN FLAME AROUND THE EXCAVATOR.

KNOW WHERE FIRE EXTINGUISHERS ARE KEPT!

UNDER ALL MAINTENANCE CONDITIONS -

Do not work on the equipment unless you are approved to do so. Then be sure you know the safe and correct procedure.

Do not work on equipment while it is being operated.

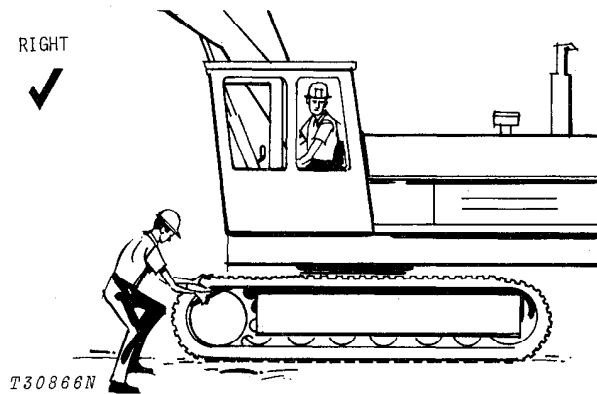

When the engine is running, avoid working on the excavator unless the procedure is approved.

If you must work on the excavator while the engine is running, USE TWO service technicians. One must be at the controls. The other must be within sight of the operator.

KEEP HANDS AWAY FROM MOVING PARTS.

Put a support under all raised equipment.

Do not work under a raised bucket.

Lower the bucket to the ground.

If the excavator is on a slope, use blocks to hold it in place.

Do not lift heavy parts by yourself. Use hoisting equipment for this.

TAKE CARE! WATCH OUT FOR OTHER PEOPLE IN THE AREA.

When you drill, grind, or hammer metal, wear safety glasses.

BE CAREFUL DURING SERVICE AND REPAIR

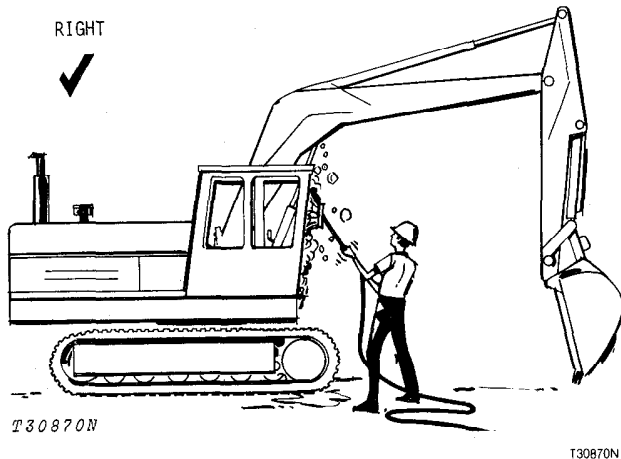

Keep ALL equipment free of dirt and oil.

Clean oil, grease, mud, ice or snow from the operator's station, steps and hand rails.

When you get the engine ready for storage, remember that inhibitor changes easily into gas and is dangerous. After you add the inhibitor, seal and tape openings. When you are not using the inhibitor, keep the can tightly closed.

Do not remove the radiator cap unless the engine is cool. First, loosen the cap slowly to the stop. Then release all pressure before you remove the cap.

Before you work on the hydraulic system:

- Stop the engine.
- Lower bucket to ground.
- Operate control levers until boom and bucket do not move.
- Remove hydraulic reservoir cap slowly.
- Open the diffuser vent.

When you check hydraulic pressure, be sure to use the correct test gauge.

Before you work on the fuel system, close the fuel shutoff valve.

Before you work on the electrical system, or make a major overhaul, disconnect the batteries.

KNOW EQUIPMENT IS READY!

All parts should be in good condition and fastened in place.

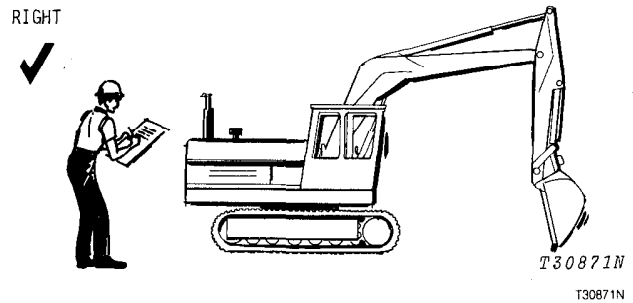

Carefully inspect all systems for leaks.

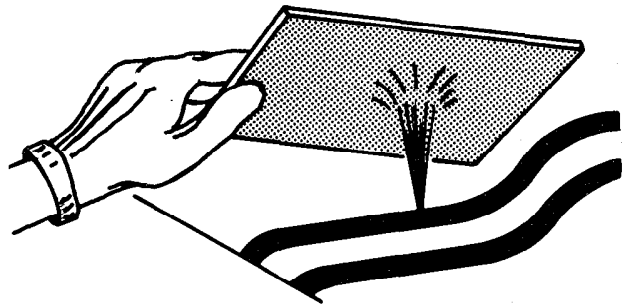

Escaping fluid under pressure can have sufficient force to penetrate the skin, causing serious personal injury. Before disconnecting lines, be sure to relieve all pressure. Before applying pressure to the system, be sure all connections are tight and that lines, pipes and hoses are not damaged. Use a piece of cardboard or wood, rather than hands, to search for suspected leaks.

If injured by escaping fluid, see a doctor at once. Serious infection or reaction can develop if proper medical treatment is not administered immediately.

Cylinders:	Bore	Rod Diameter
Boom (20)	5 in. (127 mm)	2.75 in. (70 mm)
Crowd and bucket	5.5 in. (140 mm)	3.25 in. (83 mm)

All cylinders have phenolic wear rings. Boom and crowd cylinders have a built-in hydraulic cushion at each end of the stroke. Bucket cylinder has hydraulic cushion at rod end. Full-frontal hydraulic oil cooler is in front of engine coolant radiator.

Operating Information:

Swing speed	7 rpm
Digging depth	21 ft. (6.40 m)
Reach at ground level from center of rotation	30 ft. (9.14 m)
Dumping height	15 ft. (4.57 m)
Bucket tangential digging force:	
24, 30, or 36 in. (610, 762 or 914 mm) bucket	25,780 lb. (115.55 kN) (11 694 kg)
48 in. (122 m) bucket	30,945 lb. (183.70 kN) (14 037 kg)
60 in. (1.52 m) bucket	33,981 lb. (152.31 kN) (15 414 kg)
24 or 29 in. (610 or 737 mm) rock bucket	26,695 lb. (119.65 kN) (12 109 kg)
35 in. (889 mm) rock bucket	29,210 lb. (130.93 kN) (13 250 kg)
Arm digging force:	
24, 30, or 36 in. (610, 762 or 914 mm) bucket	13,290 lb. (59.57 kN) (6028 kg)
48 in. (1.22 m) bucket	14,065 lb. (63.04 kN) (6380 kg)
60 in. (1.52 m) bucket	14,465 lb. (64.84 kN) (6561 kg)
24 or 29 in. (610 or 737 mm) rock bucket	13,475 lb. (60.40 kN) (6112 kg)
35 in. (889 mm) rock bucket	13,880 lb. (62.21 kN) (6296 kg)
Gradability	70 percent
Travel (2 speed)	0 to 0.9 mph (1.45 km/h) 0 to 1.7 mph (2.74 km/h)

Boom and Dipperstick:

Tapered box construction with heat-treated steel bushings. Machined and bored after welding for accurate alignment.

Track Rollers and Idlers:

Nine rollers and one idler per track. All rollers and idlers have metal-faced seals. Idlers have heavy-duty spring recoil mechanisms. Through-hardened steel slides support and guide upper track.

Track Shoes:

Width	Shoes	Ground Contact	Ground Pressure
24 in. (609 mm)	Triple semigrouzers	6136 sq. in. (39 577 cm ²)	6.5 psi (44.8 kPa) (0.46 kg/cm ²)
30 in. (762 mm) (optional)	Triple semigrouzers	7670 sq. in. (49 472 cm ²)	5.2 psi (35.8 kPa) (0.37 kg/cm ²)
Track adjustment		Hydraulic	

Swing Mechanism:

Swing

Turntable bearing

Case-hardened ring and pinion gears run in lubricant.

Undercarriage:

Propel motors (one for each track)

Multiple-disk brakes automatically release while propelling, and apply when stationary. Independent drive to each track permits counterrotation.

Undercarriage, car body, and track frame

Each track frame is a formed, reinforced U-channel. Track frames are joined by reinforced boxed car body with swing bearing mount.

Cab:

Steel, with urethane sound-proofing on ceiling and cushioned neoprene floor mat. Safety glass on all sides and top. Front and rear windows open. Front window can be stored overhead.

Seat:

Fully-adjustable, foam-rubber cushioned seat.

Controls:

Two-lever for boom, crowd, bucket, and swing. Right and left pedals control forward and rearward movement of right and left tracks respectively.

Servicing and Vandal Protection:

Swingaway service doors expose built-in platforms for easy access to engine and hydraulic systems. Crank-operated bolts secure service doors. Cab and access covers to fuel tank, radiator, and air filters lock with ignition key.

Capacities:	U.S.	Imp.	Liters
Fuel tank	60 gal.	50.0 gal.	227.1
Cooling system	11.25 gal.	9.4 gal.	42.6
Engine lubrication	18 qt.	15.0 qt.	17.0
Engine lubrication, including filter	20 qt.	16.7 qt.	18.9
Hydraulic system	80 gal.	66.7 gal.	302.8
Planetary propel drive	10 qt.	8.3 qt.	9.4
Swing drive	8 qt.	6.7 qt.	7.5

Additional Standard Equipment:

- Electric hour meter
- Alternator charge indicator light
- Hydraulic oil filter pressure warning light
- Engine cooling temperature gauge
- Fuel gauge
- Hydraulic oil temperature gauge
- Engine oil pressure gauge
- Key switch
- Cold weather starting aid
- Horn
- Deluxe seat
- Positive-position hand throttle
- Counterweight, 4330 lb. (1964 kg)
- Counterweight, center, 290 lb. (131 kg)
- Cab heater

Special Equipment:

- Side cutter attachments for rock bucket
- 500-lb. (227 kg) ripper tooth
- 2000-lb. (907 kg) counterweight
- 30-in. (762 mm) tripple semigrouser shoes
- Track guides
- Window protection kit
- Air conditioner
- Doubled flanged rollers
- Pilot controls

Weights:

	lb.	kg.
Operating weight, excavator less bucket:		
Standard gauge	38,300	17 373
Wide gauge	38,700	17 554
Upper structure (without boom and undercarriage)	12,470	5656
Undercarriage:		
24-in. (609 mm) shoes	15,850	7190
30-in. (762 mm) shoes	16,030	7271
Boom less cylinder	2,500	1134
Dipperstick less cylinder, 108.14 in. (2.75 m)	1,440	653
Boom cylinder (2)	510	231
Dipperstick cylinder	470	213
Bucket cylinder plus linkage	650	295
Counterweight	4,330	1964
Counterweight, optional	2,000	907

DIMENSIONS

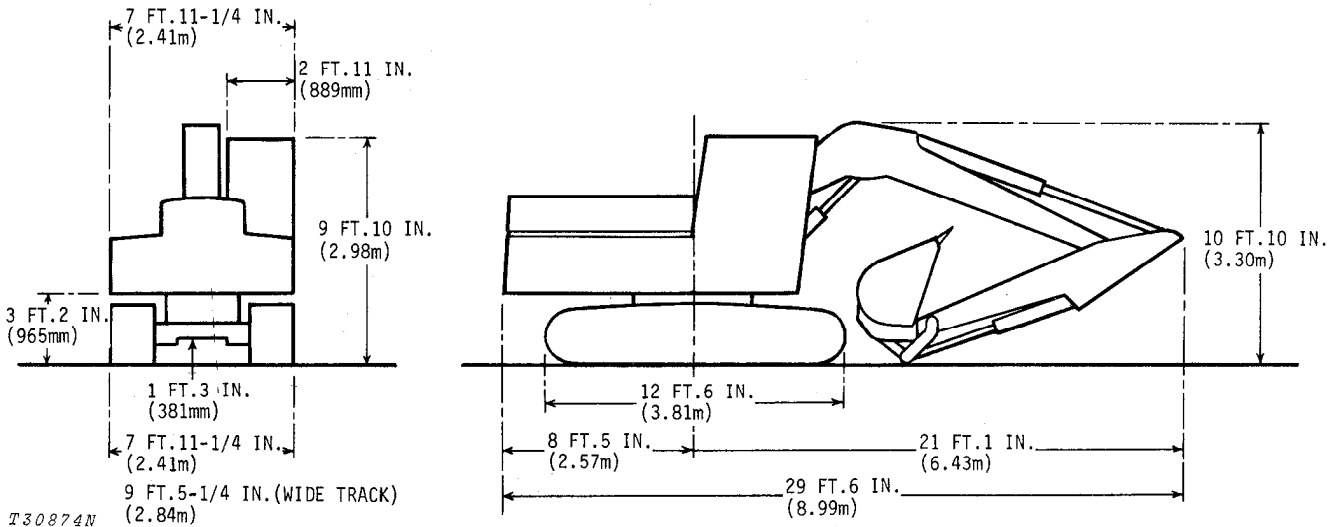

Digging Depth and Lifting Height:

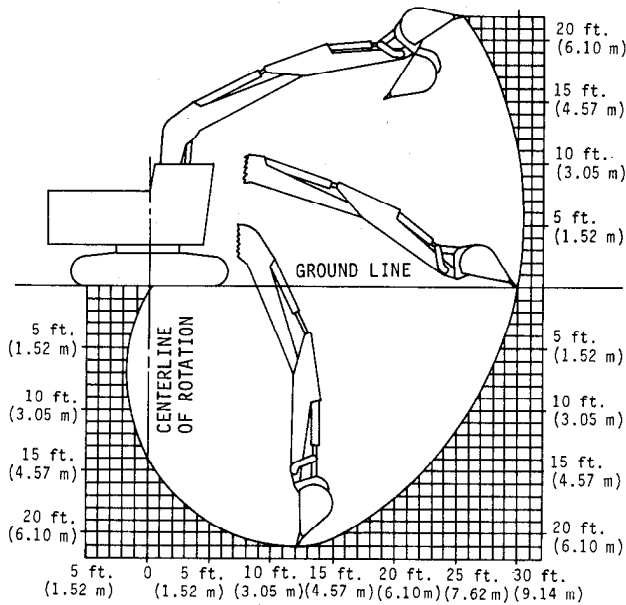

Buckets: High-strength steel, ribbed and plated bottom section

Nominal	Bite Width	SAE	Capacity		Weight
			Struck		
24 in. (610 mm)	25.4 in. (645 mm)	9/16 cu. yd. (0.43 m ³)	1/2 cu. yd. (0.38 m ³)	1000 lb. (454 kg)	
30 in. (762 mm)	31.4 in. (798 mm)	3/4 cu. yd. (0.57 m ³)	5/8 cu. yd. (0.48 m ³)	1100 lb. (500 kg)	
36 in. (914 mm)	37.4 in. (950 mm)	7/8 cu. yd. (0.67 m ³)	3/4 cu. yd. (0.57 m ³)	1200 lb. (544 kg)	
48 in. (1.22 m)	49.4 in. (1.25 m)	1 cu. yd. (0.76 m ³)	3/4 cu. yd. (0.57 m ³)	1200 lb. (544 kg)	
60 in. (1.52 m)	60.0 in. (1.52 m)	1-3/8 cu. yd. (1.05 m ³)	7/8 cu. yd. (0.67 m ³)	1200 lb. (544 kg)	
24 in. (610 mm) rock	26.0 in. (660 mm)	5/8 cu. yd. (0.48 m ³)	1/2 cu. yd. (0.38 m ³)	1380 lb. (626 kg)	
29 in. (737 mm) rock	31.0 in. (787 mm)	3/4 cu. yd. (0.57 m ³)	5/8 cu. yd. (0.48 m ³)	1500 lb. (680 kg)	
35 in. (889 mm) rock	37.0 in. (940 mm)	3/4 cu. yd. (0.57 m ³)	5/8 cu. yd. (0.48 m ³)	1525 lb. (692 kg)	

Group 10 PREDELIVERY, DELIVERY, AND AFTER-SALE SERVICES

TEMPORARY EXCAVATOR STORAGE

1. Check the battery electrolyte level. Charge the battery, if necessary.
2. Check the engine coolant level. Keep coolant 1 in. (25 mm) below the filler neck.
3. Fill the fuel tank.
4. Check the engine oil level. Oil should be between marks on dipstick after the engine has been stopped for 10 minutes.

Release hydraulic pressure:

- Stop engine.
- Lower bucket to ground.
- Operate control levers until boom and bucket do not move.

NOTE: For long-term storage (over 30 days) information, see your JD690-B Operator's Manual.

PREDELIVERY SERVICE

The service technician must carefully check and service the machine before the dealer delivers it to the customer. When the customer receives a machine that is correctly prepared, the customer is well-satisfied. For these reasons, correct predelivery service is very important to the dealer and the customer.

Use the following list when you get a unit ready for delivery to the customer.

1. Engine Oil Level

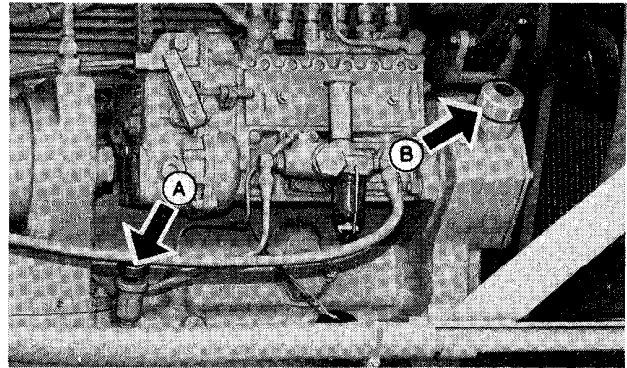

Fig. 1-Engine Oil Level

TR2241

Check engine oil level.

1. Park excavator on level surface.
2. Stop engine.
3. Wait 10 minutes for oil to drain into oil pan.
4. Remove dipstick (A) to check oil level.
5. Oil should be between marks on dipstick.
6. If not, remove filler cap (B). Add oil specified on page 10-15-2.

Oil level checked

Yes No

2. Hydraulic Reservoir Oil Level

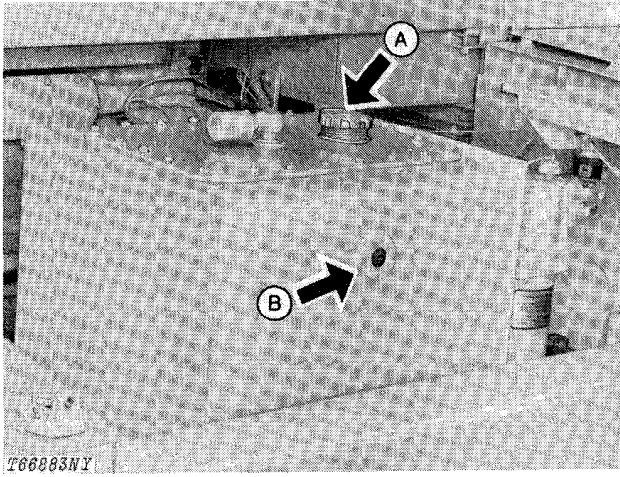

Fig. 2-Hydraulic Reservoir

Check the oil level of the hydraulic reservoir.

Park the excavator on level ground. Extend all cylinders halfway.

Oil level should be to the middle of the oil level window (B).

If oil is needed, remove the filler cap (A) slowly. Add oil specified on page 10-15-2.

NOTE: Add 2-1/2 gallons (9.5 L) of oil to raise oil level in reservoir 1 in. (25.4 mm).

IMPORTANT: Oil trapped in the lower part of the sight glass may not show the correct oil level.

Oil level checked Yes No

3. Swing Gearbox Oil Level

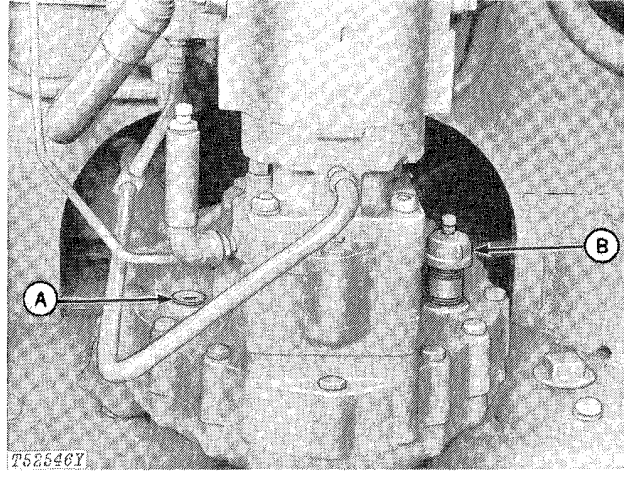

Fig. 3-Swing Gearbox

Check the oil level of the swing gearbox.

Oil should be to the bottom of the check plug hole (A). If not, remove the pipe cap (B). Add oil specified on page 10-15-2.

Install the check plug and the pipe cap.

Swing gearbox oil level checked Yes No

4. Track Gearbox Oil Level

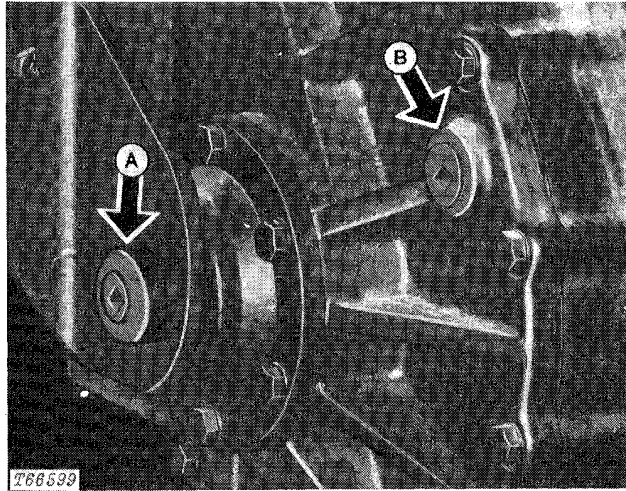

Fig. 4-Track Gearbox

Check oil level of both track gearboxes.

Remove the check plug (A).

Oil should be to the level of the check plug hole. If not, remove the fill plug (B). Add oil specified on page 10-15-2.

Install both plugs.

Oil level checked Yes No

5. Track Rollers and Idlers

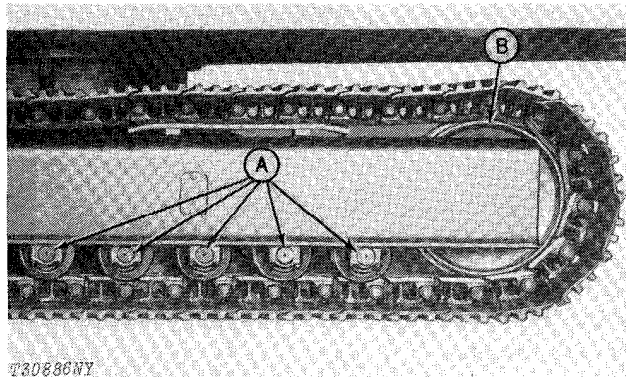

Fig. 5-Track Rollers and Front Idler

Check rollers (A) and front idlers (B) for oil leaks.

Oil level checked Yes No

6. House Lock Oil Level

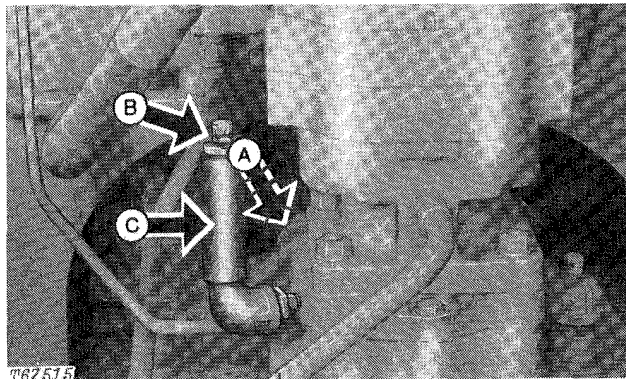

Fig. 6-House Lock Oil Level

Check oil level of house lock.

Stop engine.

Remove pipe plug (A).

Oil should be at bottom of pipe plug hole.

If not, remove vent and bushing (B).

Add oil specified on page 10-15-2 through coupling (C).

Install all parts.

Oil level checked Yes No

7. Propel Brake Oil Level

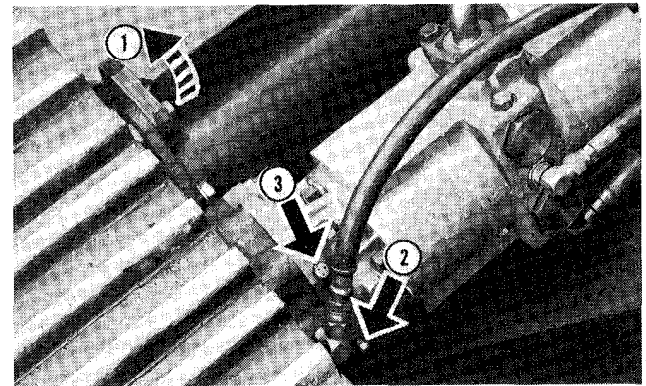

Fig. 7-Propel Brake Oil Level

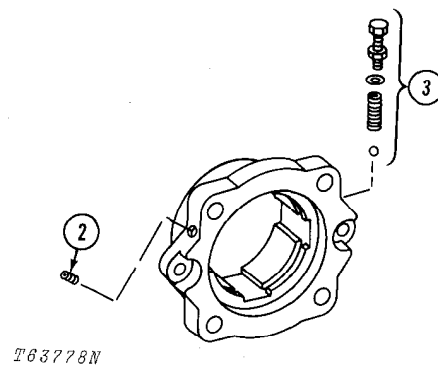

Fig. 8-Propel Brake Oil Level

Check the oil level of propel brakes.

1. Swing house to rear. Remove the cap screw from the propel motor cover. Pivot cover to rear.
2. Remove the pipe plug. Oil should be at pipe plug hole.

3. If not, remove the breather vent, washer, spring, and steel ball. Put these parts in a safe place. Add oil specified on page 10-15-2.

4. Install parts.

IMPORTANT: If the breather vent is dirty, flush it with fuel oil or solvent. Use compressed air to clean the vent.

Oil level checked Yes No

8. Pre-Cleaner

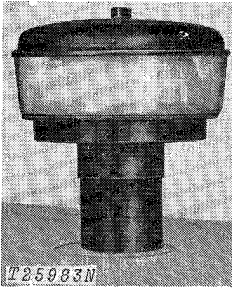

Fig. 9-Pre-Cleaner

Check the pre-cleaner bowl. Clean it if necessary.

Pre-cleaner checked Yes No

9. Air Cleaner

Check the air filter indicator light. If the indicator light glows red, clean the primary air filter element. Install new primary and safety filter elements, if necessary.

Air cleaner checked Yes No

10. Air Intake Hoses

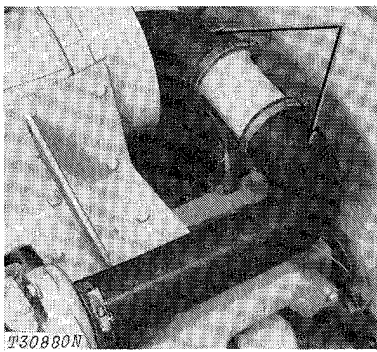

Fig. 10-Air Intake Hoses

Check the clamps on the hoses that connect the air cleaner and the engine.

Tighten the four hose clamps. Inspect the hoses for cracks.

Air intake hoses checked Yes No

11. Radiator

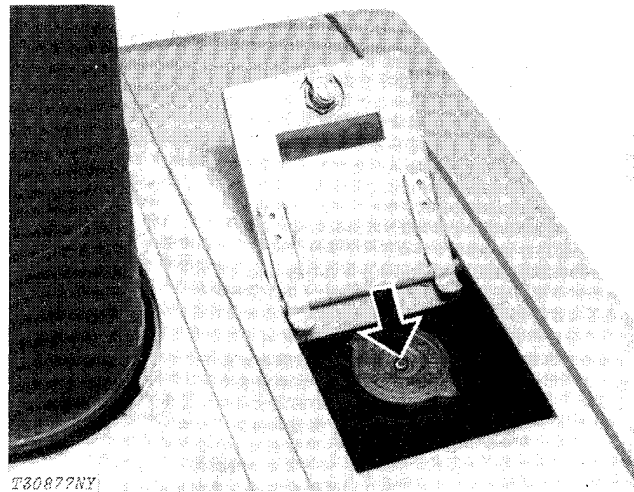

Fig. 11-Radiator Cap

CAUTION: Do not remove the radiator cap unless the engine is cool. Loosen the cap slowly to the stop. Then release all pressure before you remove the cap.

Check the coolant level. Keep coolant 1 in. (25 mm) below the filler neck.

Use clean, soft water for warm weather. Use a solution of 50% clean, soft water and 50% permanent anti-freeze (ethylene glycol with approved rust inhibitor) for cold weather.

Tighten the filler cap.

Check for leaks or loose connections. Clean the radiator fins if necessary.

Coolant level checked Yes No

12. Batteries

Check the electrolyte level of the batteries. Add distilled water, if necessary. Clean batteries with a damp cloth. Put petroleum jelly on terminals.

IMPORTANT: If you add water to the batteries in freezing weather, run the engine 2 or 3 hours or charge the batteries.

Check battery connections.

Punch date code on batteries.

Batteries checked Yes No

13. Fuel Filters

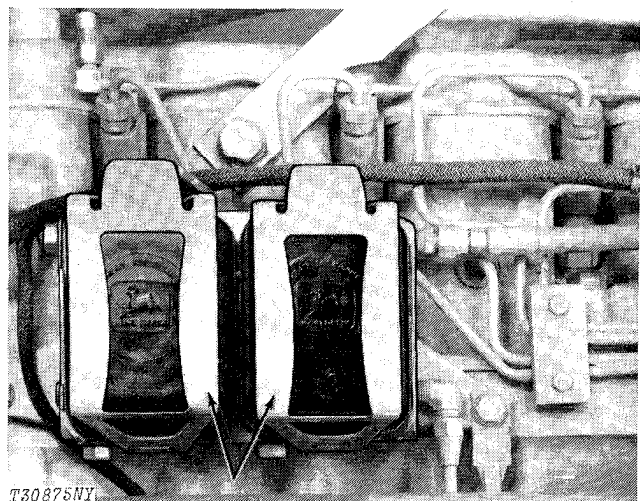

Fig. 12-Fuel Filters

Check the fuel filters. Drain sediment. Remove air from the fuel system. See page 10-10-23.

Fuel filters checked Yes No

14. Fuel Supply Pump Sediment Bowl

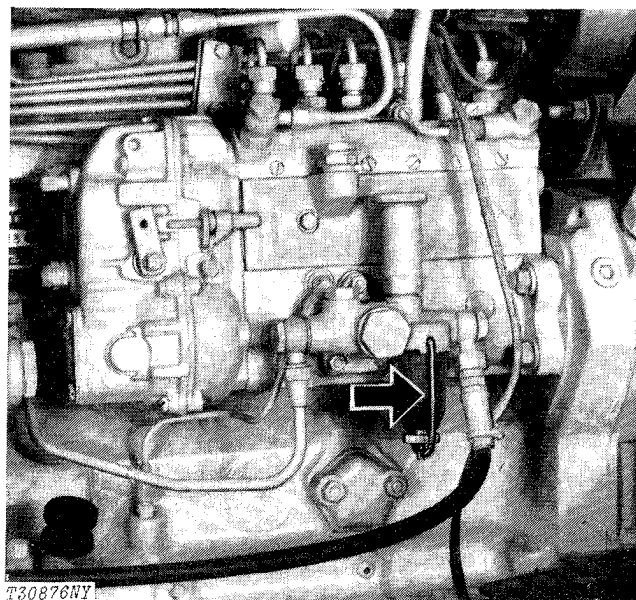

Fig. 13-Fuel Supply Pump Sediment Bowl

Check the fuel supply pump sediment bowl. Drain it if necessary.

Sediment bowl checked Yes No

15. Fan Belt

Check the tension of the fan belts.

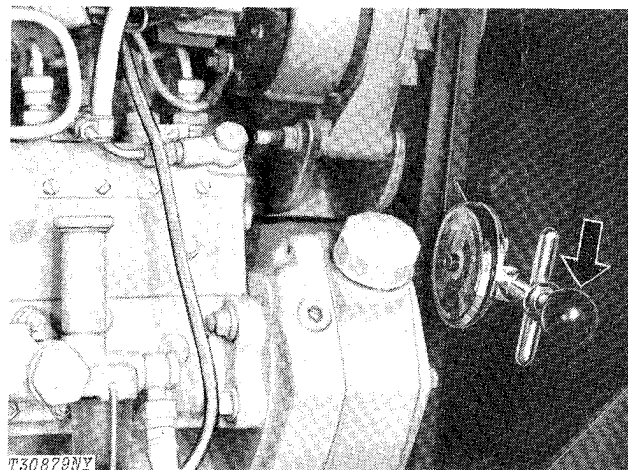

Fig. 14-Strand Tension Gauge

Strand tension gauge: Immediately after the engine stops (run the engine 5 minutes or more), check the belt tension. If strand tension is less than 50 lb. (223 N), let the engine cool 10 to 15 minutes. Then make tension 90 lb. (400 N). Check the front belt only.

Tension tester: A force of 20 lb. (89 N) halfway between the pulleys should move the belt 3/4 in. (19 mm).

Adjustment: Loosen the alternator bracket and adjusting cap screws.

IMPORTANT: Apply force to the **FRONT** alternator frame only.

Tighten the cap screws.

NOTE: On units with air conditioning, the compressor belt should move 1/4 in. (6 mm) when 15-lb. (67 N) force is applied to the belt halfway between the pulleys.

Belt tension checked Yes No

16. Engine Speeds

Check the engine speeds.

Install a tachometer in the tachometer drive. See page 10-10-24.

Run engine until it is warm.

Slow idle should be 800 rpm.

Fast idle should be 2650 rpm.

If engine speed control linkage needs adjustment, see page 10-10-25.

Engine speeds checked Yes No

17. Grease Fittings

Lubricate each point with two shots of John Deere Multi-Purpose Grease or equivalent, except where noted.

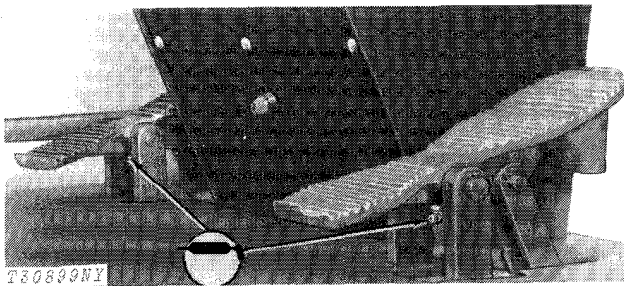

Fig. 15-Mechanical System Pedals (2 points)

Lubrication required Yes No

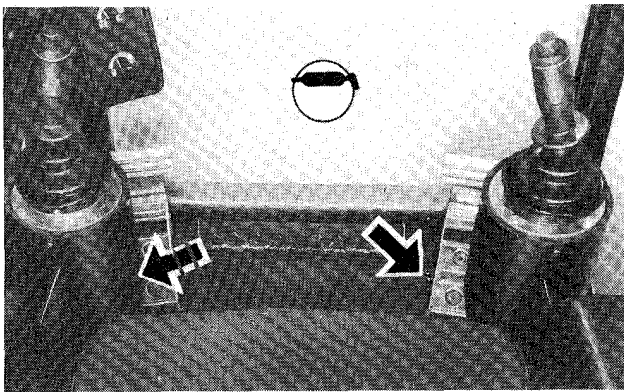

Fig. 16-Pilot System Pedals (2 points)

Lubrication required Yes No

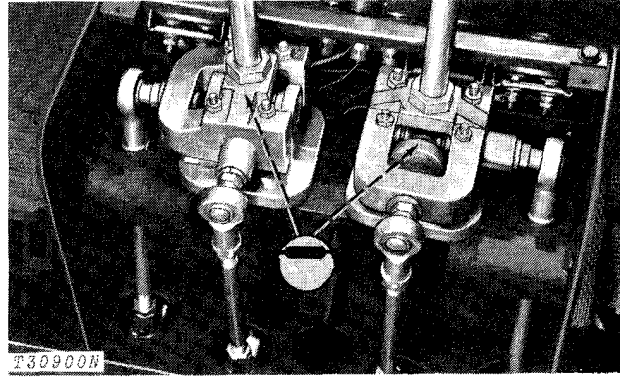

Fig. 17-Control Lever Pivots (2 points)
 (Mechanical System)

Lubricate with one shot of grease.

Lubrication required Yes No

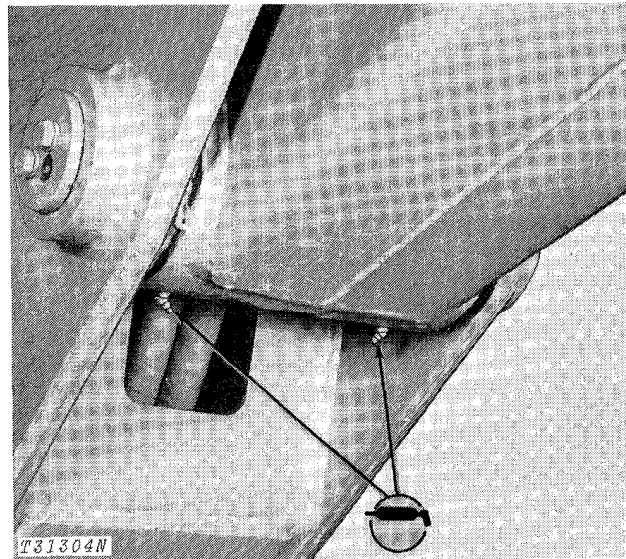

Fig. 18-Boom-To-Dipperstick Pin (2 points)

Lubrication required Yes No

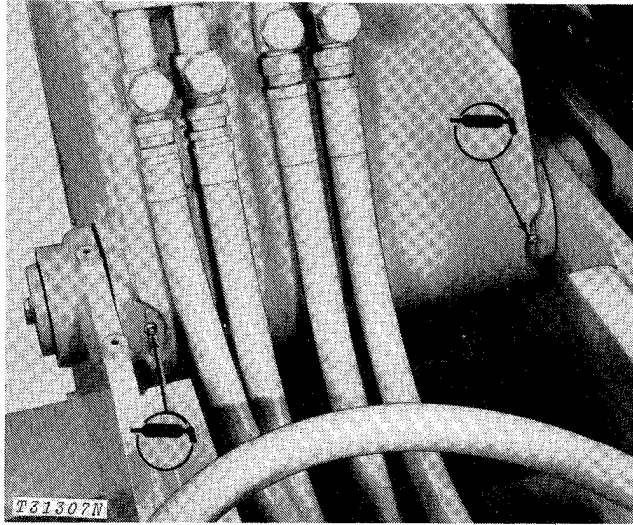

Fig. 19-Boom-to-Main-Frame (2 points)

Lubrication required Yes No

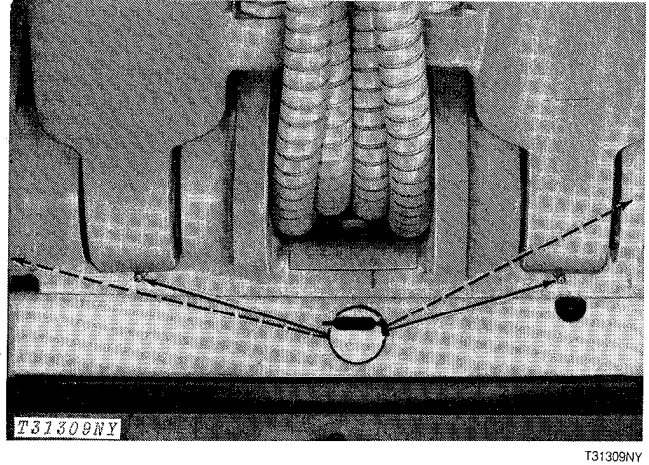

Fig. 21-Boom Cylinder - Head End (4 points)

Lubrication required Yes No

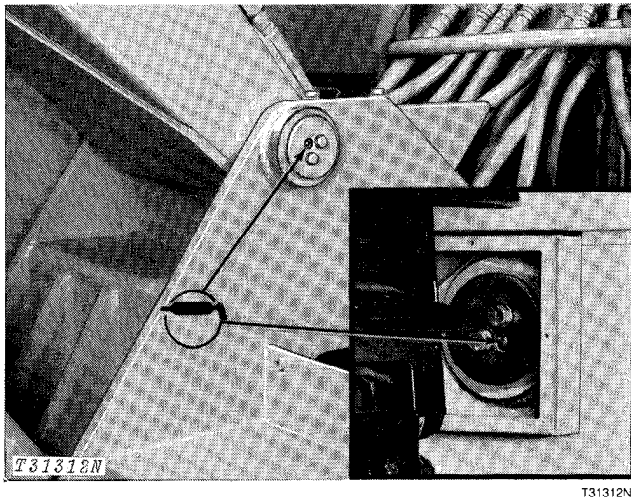

Fig. 20-Main-Frame-To-Boom Pin (2 points)

NOTE: Right-hand fitting (see inset) is to left of operator's seat; remove cover from box.

Lubrication required Yes No

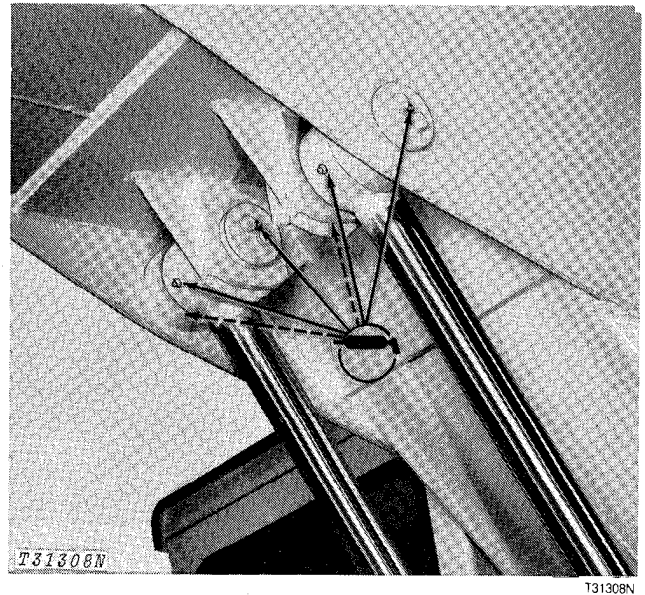
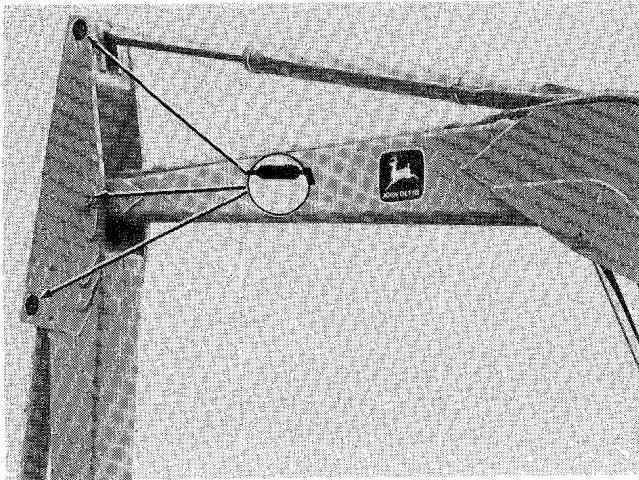

Fig. 22-Boom Cylinder - Rod End (6 points)

Lubrication required Yes No



NB2603

Fig. 23-Grease Fittings (6 point's total)

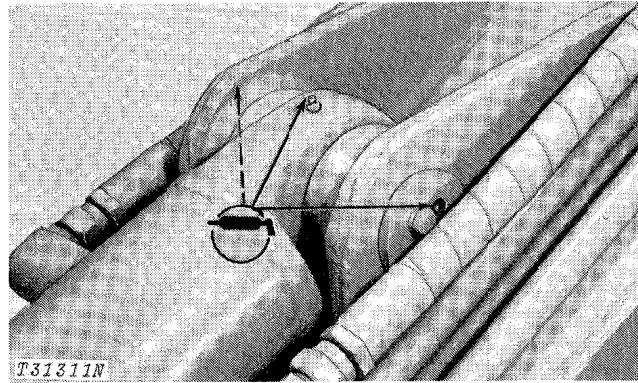

T31311N

T31311N

Fig. 25-Crowd Cylinder - Head End (3 points)

Lubrication required

Yes No

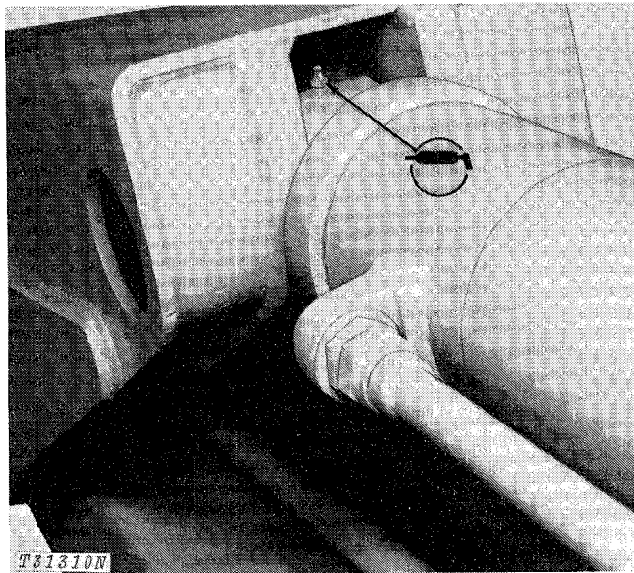

T31310N

T31310N

Fig. 24-Crowd Cylinder - Rod End (1 point)

Lubrication required

Yes No

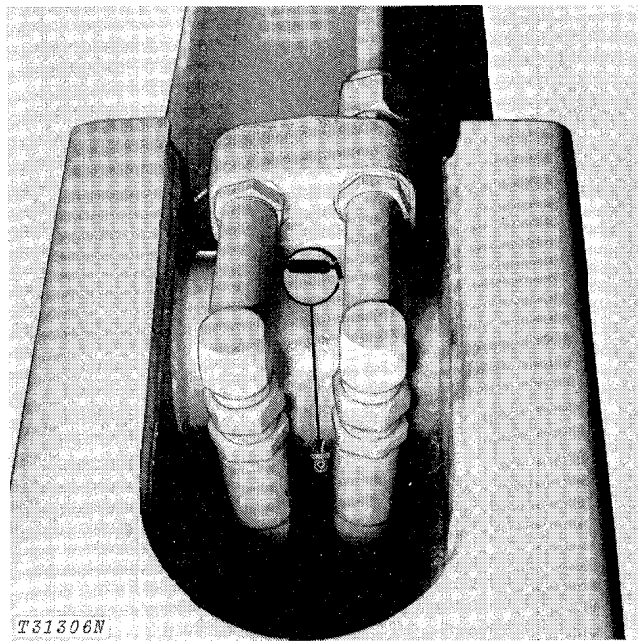

T31306N

T31306N

Fig. 26-Bucket Cylinder - Head End (1 point)

Lubrication required

Yes No



Suggest:

If the above button click is invalid.

Please download this document

first, and then click the above link

to download the complete manual.

Thank you so much for reading

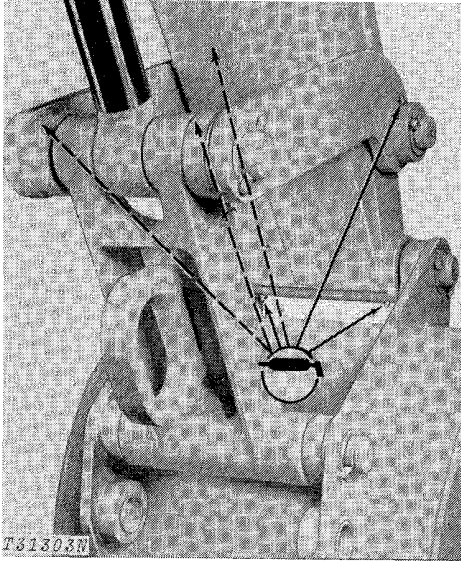

Fig. 27-Bucket Linkage (6 points)

Lubrication required Yes No

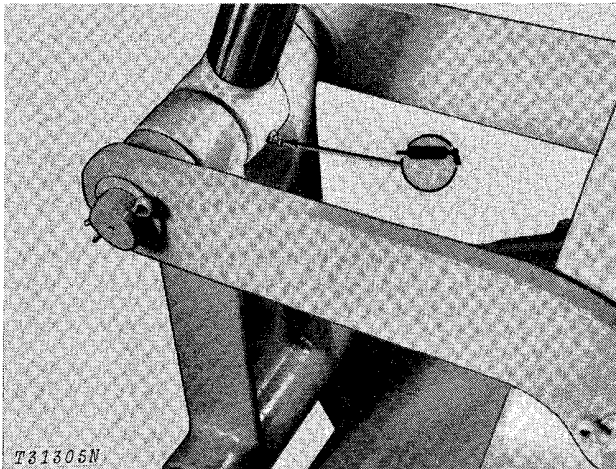

Fig. 28-Bucket Cylinder - Rod End (1 point)

Lubrication required Yes No

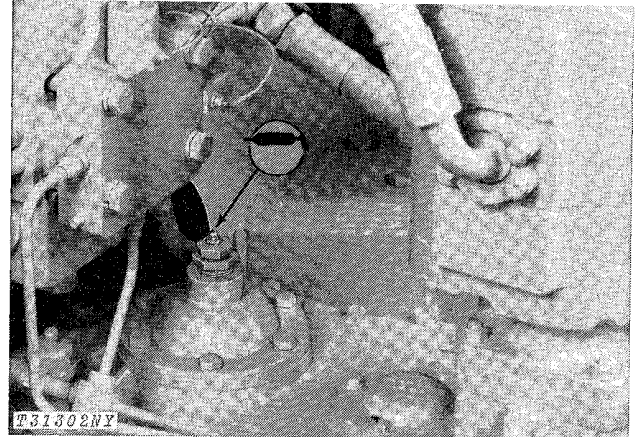

Fig. 29-Swing Gearbox Bearing Quill (1 point)

Lubrication required Yes No

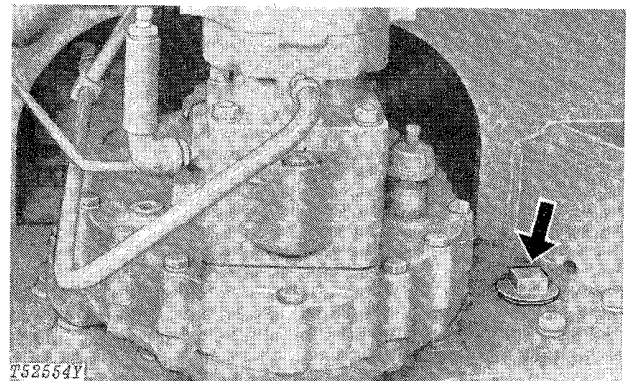

Fig. 30-Swinging Gear Filler Plug

Check for sufficient grease.

Remove filler plug.

Approximately 1/4 in. (6 mm) of grease should be in bottom of trough and approximately 1/8 in. (3 mm) of grease on upper surface of ring gear.

If not, add grease specified on page 10-15-2.

Install plug.

Lubrication required Yes No

<https://www.ebooklibonline.com>

Hello dear friend!

Thank you very much for reading.

Enter the link into your browser.

The full manual is available for immediate download.

<https://www.ebooklibonline.com>