

690 and 690-A Excavators

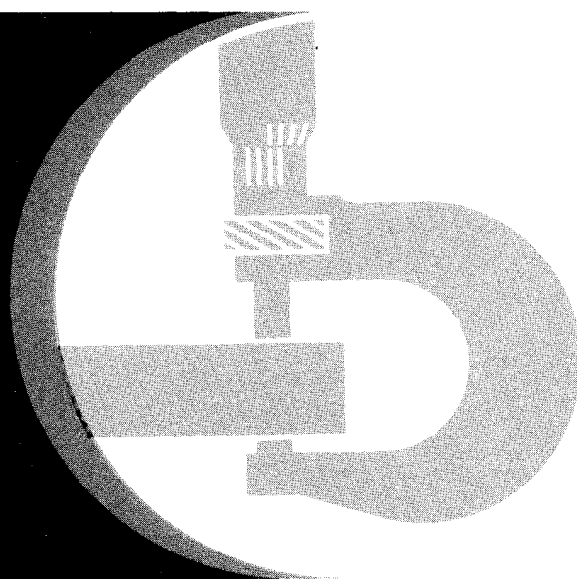

TECHNICAL MANUAL

TM-1017

LITHO IN U.S.A.

JD690 and JD690-A EXCAVATORS

Technical Manual TM-1017 (Jan-74)

CONTENTS

SECTION 10 - GENERAL	SECTION 50 - POWER TRAIN
Group 5 - Specifications	Group 5 - Track and Swing Drive Assemblies
Group 10 - Predelivery, Delivery, and After-Sales Services	
Group 15 - Tune-Up and Adjustment	SECTION 60 - STEERING AND BRAKES
Group 20 - Lubrication	Group 5 - General Information
Group 25 - Separation	
SECTION 20 - ENGINE	SECTION 70 - HYDRAULIC SYSTEM
Group 5 - Diagnosis	Group 5 - General Information, Testing, and Diagnosis
Group 10 - Basic Engine	Group 10 - Main Hydraulic Pump
Group 15 - Engine Lubrication	Group 15 - Control Valve
Group 20 - Speed Control Linkage	Group 20 - Hydraulic Motors
Group 25 - Engine Cooling System	Group 25 - Rotary Manifold and Brake Valve
Group 30 - Specifications and Special Tools	Group 30 - Cylinders
	Group 35 - Flow Divider Valve
SECTION 30 - FUEL SYSTEM	Group 40 - Reservoir, Cooler and Filters
Group 5 - System Diagnosis	Group 45 - Specifications and Special Tools
Group 10 - Fuel Tank, Transfer Pump and Filters	
Group 15 - Air Intake System	SECTION 80 - MISCELLANEOUS COMPONENTS
Group 20 - Fuel Injection Pumps	Group 5 - Undercarriage
. - Fuel Injection Nozzles (refer to SM-2045)	Group 10 - Boom and Bucket
Group 25 - Specifications and Special Tools	Group 15 - Specifications and Special Tools
SECTION 40 - ELECTRICAL SYSTEM	SECTION - INDEX
Group 5 - Wiring Diagrams	
Group 10 - Charging Circuit	
Group 15 - Starting Circuit	
Group 20 - Gauges and Switches	
Group 25 - Specifications and Special Tools	

The specifications and design information contained in this manual were correct at the time it was printed. It is John Deere's policy to continually improve and update our machines. Therefore, the specifications and design information are subject to change without notice. Wherever applicable, specifications and design information are in accordance with SAE and IEMC standards.

Copyright 1969
DEERE & COMPANY
Moline Illinois
All rights reserved

INTRODUCTION

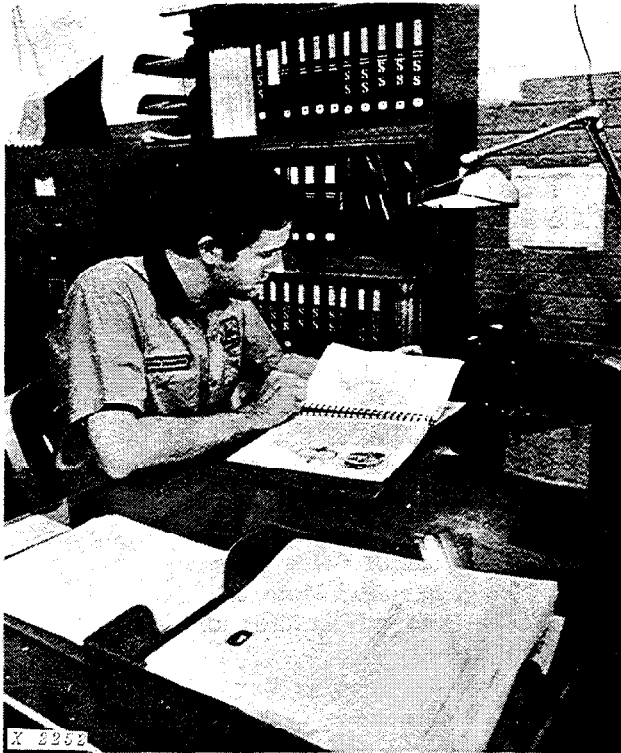

Use FOS Manuals for Reference



Use Technical Manuals for Actual Service

This technical manual is part of a twin concept of service:

- **FOS Manuals**—for reference
- **Technical Manuals**—for actual service

The two kinds of manuals work as a team to give you both the general background and technical details of shop service.

Fundamentals of Service (FOS) Manuals cover basic theory of operation, *fundamentals* of trouble shooting, *general* maintenance, and *basic* types of failures and their causes. FOS Manuals are for training new men and for reference by experienced men.

Technical Manuals are concise service guides for a specific machine. Technical Manuals are on-the-job guides containing only the vital information needed by a journeyman mechanic.



When a serviceman should refer to a FOS Manual for more information, a FOS symbol like the one at the left is used in the TM to identify the reference.

Some features of this technical manual:

- *Table of contents at front of manual*
- *Exploded views showing parts relationship*
- *Photos showing service techniques*
- *Specifications grouped for easy reference*

This technical manual was planned and written for you—a journeyman mechanic. Keep it in a permanent binder in the shop where it is handy. Refer to it whenever in doubt about correct service procedures or specifications.

Using the technical manual as a guide will reduce error and costly delay. It will also assure you the best in finished service work.



This safety alert symbol identifies important safety messages in this manual. When you see this symbol, be alert to the possibility of personal injury and carefully read the message that follows.

COMPLETE PAGE LISTING
 WITH LATEST DATE LINES

1, 2	(Jan-74)	40-5-1, 2	(Jan-74)
3, 4	(Jul-75)	40-5-3, 4	(May-72)
		40-5-5, 6	(May-72)
10-5-1, 2	(Jul-73)	40-5-7, 8	(May-72)
10-10-1, 2	(May-72)	40-5-9, 10	(Jan-74)
10-10-3, 4	(May-72)	40-10-1, 2	(May-72)
10-15-1, 2	(May-72)	40-10-3, 4	(May-72)
10-15-3, 4	(May-72)	40-10-5, 6	(May-72)
10-20-1, 2	(May-73)	40-10-7, 8	(Oct-73)
10-25-1, 2	(Jul-73)	40-10-9, 10	(May-72)
10-25-3, 4	(Jul-73)	40-15-1, 2	(Jan-73)
10-25-5, 6	(Jul-73)	40-15-3, 4	(Jul-74)
10-25-7, 8	(Jul-73)	40-15-5, 6	(Jul-73)
		40-15-7, 8	(Jul-73)
20-5-1, 2	(May-72)	40-15-9, 10	(Jul-73)
20-5-3, 4	(May-72)	40-15-11, 12	(Jan-74)
20-10-1, 2	(Jul-73)	40-15-13, 14	(Apr-74)
20-10-3, 4	(Jan-74)	40-20-1, 2	(May-72)
20-10-5, 6	(Jul-73)	40-25-1, 2	(Apr-73)
20-10-7, 8	(Jul-75)	40-25-3, 4	(Apr-74)
20-10-9, 10	(Oct-73)	40-25-5, 6	(Jan-73)
20-10-11, 12	(May-72)		
20-10-13, 14	(May-72)	50-5-1, 2	(May-72)
20-15-1, 2	(May-72)	50-5-3, 4	(May-72)
20-15-3, 4	(Oct-73)		
20-20-1, 2	(May-72)	60-5-1, 2	(May-72)
20-25-1, 2	(May-72)		
20-25-3, 4	(May-72)	70-5-1, 2	(May-72)
20-30-1, 2	(Jul-73)	70-5-3, 4	(Jul-73)
20-30-3, 4	(Jul-75)	70-5-5, 6	(Jul-75)
20-30-5, 6	(Jul-73)	70-5-7, 8	(Apr-74)
20-30-7, 8	(May-72)	70-10-1, 2	(Jul-75)
		70-10-3, 4	(Jul-75)
30-5-1, 2	(May-72)	70-15-1, 2	(May-72)
30-10-1, 2	(May-72)	70-15-3, 4	(May-72)
30-10-3, 4	(May-72)	70-15-5, 6	(Apr-73)
30-15-1, 2	(May-72)	70-20-1, 2	(May-72)
30-15-3, 4	(May-72)	70-20-3, 4	(Jul-75)
30-15-5, 6	(May-72)	70-20-5, 6	(Jul-75)
30-15-7, 8	(May-72)	70-25-1, 2	(May-72)
30-20-1, 2	(May-72)	70-25-3, 4	(May-72)
30-20-3, 4	(May-72)	70-25-5, 6	(Apr-74)
30-20-5, 6	(Apr-73)	70-30-1, 2	(Jul-73)
30-20-7, 8	(Jul-75)	70-35-1, 2	(Oct-73)
30-25-1, 2	(May-72)	70-35-3, 4	(Apr-73)
30-25-3, 4	(Jan-73)	70-40-1, 2	(May-72)
		70-40-3, 4	(May-72)
		70-45-1, 2	(Jul-75)
		70-45-3, 4	(Jul-75)

Vertical lines indicate pages included with this revision.

<https://www.ebooklibonline.com>

Hello dear friend!

Thank you very much for reading.

Enter the link into your browser.

The full manual is available for immediate download.

<https://www.ebooklibonline.com>

**COMPLETE PAGE LISTING
WITH LATEST DATE LINES**

80-5-1, 2	(Jan-73)
80-5-3, 4	(Jan-73)
80-5-5, 6	(Jan-73)
80-5-7, 8	(Jul-75)
80-5-9, 10	(Jul-73)
80-10-1, 2	(Jan-73)
80-10-3, 4	(Jul-73)
80-15-1, 2	(Oct-73)
Index-1, 2	(Apr-73)
Index-3, 4	(Apr-73)
Index-5, 6	(Apr-73)

Vertical lines indicate pages included with this revision.

HYDRAULIC SYSTEM

Type Open center.
Pump Tandem.

Alternator . . . 12-volt, 55-amp (early units),
35-amp (later units); with in-
tegral transistorized regulator.

ELECTRICAL SYSTEM

Type 12-volt, negative grounded.
Batteries Two, 6-volt, 75-plate
360 minute reserve capacity,
3 EH type, connected in series.

MAXIMUM GROUND SPEED 1.2 mph.

WEIGHT 36,105 lbs. (less bucket).

DIMENSIONS

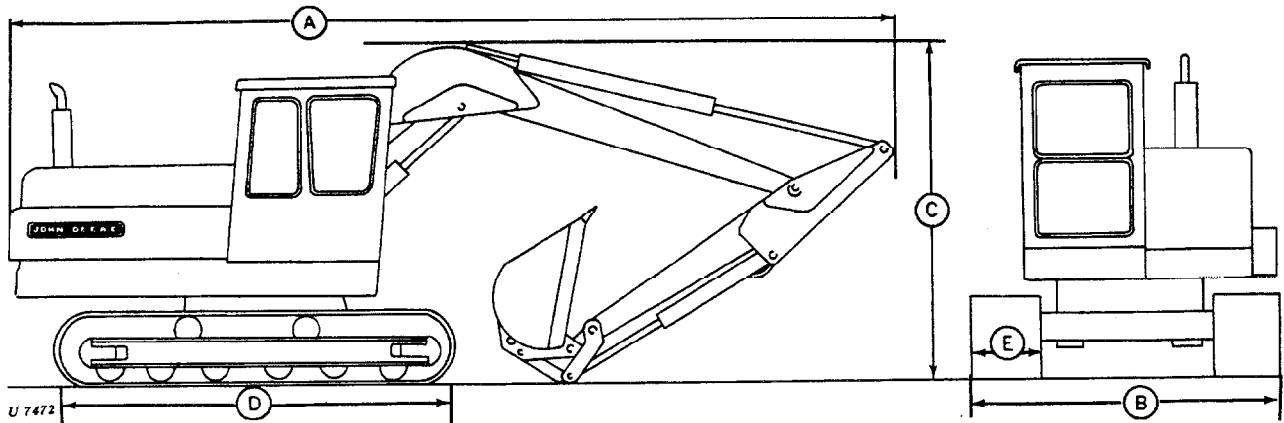

Fig. 1-Excavator Overall Dimensions

A. Length	29 ft. 6 in.
B. Width	7 ft. 11 in.
C. Height (to top of boom)	10 ft. 10 in.
D. Track length	12 ft. 6 in.
E. Track shoe width	24 in.

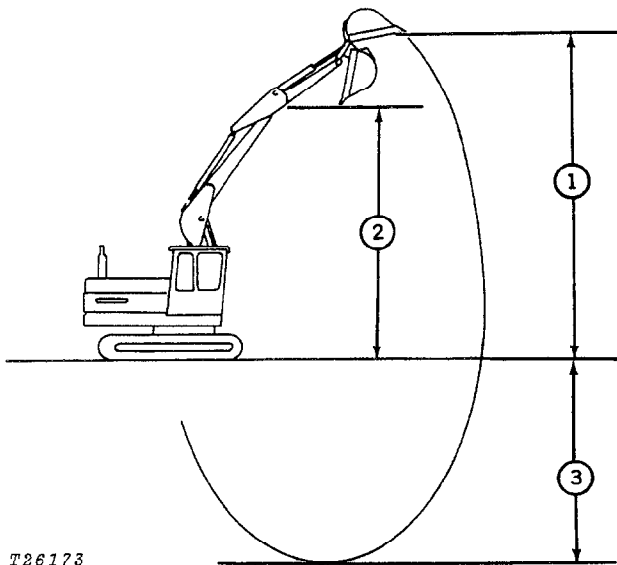

Fig. 2-Excavator Operating Dimensions

1. Maximum reach	30 ft.
2. Maximum dumping height	15 ft.
3. Maximum digging depth	21 ft.
Digging force (24 in. bucket)	23,000 lbs.
Swing, 360 degree continuous	7 rpm
Gradability	50 per cent

Specifications and design are subject to change without notice. Wherever applicable, specifications are in accordance with SAE, PCSA and I.E.M.C. Standards.

Group 10 PREDELIVERY, DELIVERY, AND AFTER-SALES SERVICES

PREDELIVERY SERVICE

Every new John Deere machine leaves the factory so that it can be delivered to the customer after a minimum of servicing.

Shipping factors, however, in addition to extra finishing touches needed for customer satisfaction, necessitate proper predelivery service by the dealer.

A tag pointing out the factory-recommended procedure for predelivery service is attached to every new machine before it leaves the factory.

After completing the factory-recommended checks and services listed on the predelivery tag, remove and file the tag with the job shop order. The tag will then certify that the unit has received the proper predelivery service.

NOTE: Remove plug from exhaust outlet and install muffler before unloading machine. Cover exhaust whenever transporting the machine.

TEMPORARY MACHINE STORAGE*

Service	Specification	Reference
Check radiator for coolant loss and anti-freeze protection.	Fill to level with baffle in neck of radiator.
Relieve hydraulic pressure.	Stop engine, lower boom and operate control handles.	Operator's Manual
Check and charge batteries.	Specific gravity is 1.240 to 1.260 (full charge).	Section 40, Group 10
Cover machine for protection and cleanliness.

**See Operator's Manual for extended storage instructions.*

BEFORE DELIVERING MACHINE

ELECTRICAL SYSTEM

Check battery terminals to be sure they are tight. Operator's Manual

Punch date code on battery tag.

Inspect electrolyte and charge batteries, if required. Bottom of filler neck. Operator's Manual

Check alternator and fan belt tension. Operator's Manual

COOLING SYSTEM

Inspect radiator for coolant loss. Fill to level with baffle in neck of radiator.

Check antifreeze protection.

TRACKS

Check track adjustment. 1-in. sag. Operator's Manual

Check chain adjustment. 1/2-in. sag. Operator's Manual

Service	Specification	Reference
LUBRICATION		
Check crankcase oil level.	To upper marks on dipstick.	Operator's Manual
Check hydraulic system oil level.	Operator's Manual
Check swing and track gearbox oil levels.	Operator's Manual
Lubricate grease fittings.	John Deere Multi-Purpose Lubricant or an equivalent.	Operator's Manual
ENGINE		
Check air cleaner.	Operator's Manual
Fill fuel tank and start engine.	Operator's Manual
Check engine idle speeds.	Section 20, Group 15
OPERATION		
Check hydraulic system operation.	Section 70, Group 5
Check flow divider valve operation.	Section 70, Group 35
Check pump disconnect.	Operator's Manual
Check gauge and indicator lamp operation.	Operator's Manual
Check swing and track motor operation.	Operator's Manual
Check swing brake operation.	Operator's Manual
Check seat operation.	Operator's Manual
GENERAL		
Tighten cap screws and nuts.
Clean machine and touch up paint.
Check air cleaner and attaching connections for potential leaks.

DELIVERY SERVICE

A thorough discussion of the operation and service of a new machine at the time of delivery helps to assure complete customer satisfaction. Proper delivery should be an important phase of a dealer's program. One section of the John Deere Delivery Receipt emphasizes the importance of proper delivery service.

Complaints may arise if the owner is not shown how to operate and service his new machine correctly. Devote enough time, at your customer's convenience, to introduce him to his new machine. Explain fully how to operate and service it.

Using the operator's manual as a guide, be sure that the owner thoroughly understands the following points:

1. Operation and use of controls and instruments.
2. Operation of the engine.
3. Importance of the break-in period.
4. Operation and functions of the hydraulic system.
5. Importance of safety.
6. Importance of lubrication and periodic services.

AFTER-SALES SERVICE

The purchaser of a new John Deere machine is entitled to a free inspection at some mutually agreeable time within the warranty period after the equipment has been "run in." The terms of this after-sales inspection are outlined on the back of the customer's John Deere Delivery Receipt.

The purpose of this inspection is to ensure that the customer is receiving satisfactory performance from his machine. At the same time, the inspection should reveal whether or not the machine is being operated, lubricated, and serviced properly.

If the recommended after-sales service inspection is followed, the dealer may eliminate minor irregularities which could develop into major service problems at a later date. This will promote strong dealer-customer relations and give the dealer an opportunity to answer questions that may have arisen during initial operation.

During the inspection service, the dealer has the opportunity to recommend additional new equipment and accessories.

INSPECTION PROCEDURES

Service	Specification	Reference
Check radiator coolant level.	Fill to level with baffle in neck of radiator.
Clean external surface of radiator core.
Check hoses and connections for leaks.
FUEL SYSTEM		
Remove water and foreign matter from fuel pump and filter sediment bowls. Replace filters, if necessary.	Operator's Manual
Tighten loose connections and check entire fuel system for leaks.
Check air cleaner elements and clean, if necessary.	Operator's Manual
ELECTRICAL SYSTEM		
Check specific gravity and electrolyte level of batteries.	Specific gravity is 1.240 to 1.260 (full charge)	Operator's Manual
Check fan belt tension.	3/4-inch deflection with 20 lbs. force; 100 to 110 lb. strand tension if belt gauge is used.	Operator's Manual
Start engine and check action of starter and indicator lamps.	Operator's Manual
ENGINE		
Check crankcase oil level.	To upper marks on dipstick.	Operator's Manual

Service	Specification	Reference
ENGINE—Continued		
Check valve clearances.	Intake - 0.018 in. Exhaust - 0.022 in.	Section 20, Group 5
Check engine speed under load.	Section 20, Group 15
HYDRAULIC SYSTEM		
Check pump disconnect operation.	Operator's Manual
Check hydraulic cylinder operation, fittings, and hose positions.	Operator's Manual
Check oil level of swing and track motor gearboxes.	Operator's Manual
TRACKS		
Check drive chain adjustment.	Section 80, Group 5
Check track adjustment.	Section 80, Group 5

Group 15

TUNE-UP AND ADJUSTMENT

GENERAL INFORMATION

The following preliminary tests can determine if an engine is in such a condition that performance can be restored by tune-up.

PRELIMINARY ENGINE TESTING

Operation	Specification	Reference
Check radiator for air bubbles and indication of oil.	Section 20, Group 20
Check cylinder compression.	400 psi minimum (25 psi maximum variation between cylinders)	FOS Manual - ENGINES
Test vacuum (air cleaner).	8 to 25 in. of water	FOS Manual - ENGINES

ENGINE TUNE-UP

AIR INTAKE SYSTEM

Check air cleaner and service as necessary.	8 in. of water clean - 25 in. or more water maximum (at 2200 rpm)	Section 30, Group 15
Restriction indicator light.	24 to 26 in. of water	Section 30, Group 15

COOLING SYSTEM

Clean grille screen, radiator core, and oil cooler core.
Clean and flush system; check thermostat.	FOS Manual - ENGINES
Check pressure cap.	FOS Manual - ENGINES

CYLINDER HEAD AND VALVES

Tighten cap screws.	130 ft-lbs	Section 20, Group 5
Set engine valve tappet clearances.	Intake - 0.018 in. Exhaust - 0.022 in.	Section 20, Group 5

ENGINE TUNE-UP—Continued

Operation	Specification	Reference
CHARGING SYSTEM		
Check battery specific gravity.	1.240 to 1.260	Section 40, Group 10
Check battery water consumption and electrolyte level.	FOS Manual - ELECTRICAL SYSTEMS
Clean battery, cables, and box.
Check alternator belt tension.	Section 20, Group 20
Check fan belt tension.	Section 20, Group 20
Check alternator.	Section 40, Group 10
FUEL SYSTEM		
Check fuel tank for water.
Check fuel pump pressure.	Section 30, Group 10
Clean sediment bowls and change filter.	Section 30, Group 10
Check injection nozzles.	SM-2045 "Testing and Servicing Fuel Injection Pumps and Nozzles"
Check injection pump advance.	Section 30, Group 20
Adjust throttle linkage.	Section 20, Group 15
Check engine oil pressure.	40 to 50 psi (1900 rpm) (normal operating temperature)	Section 20, Group 10

EXCAVATOR ADJUSTMENTS

Operation	Specification	Reference
HYDRAULIC SYSTEM CYCLE TIMES	Section 70, Group 5
UNDERCARRIAGE ADJUST- MENTS		
Check track tension.	Section 80, Group 5
Check chain tension.	Section 80, Group 5
TIGHTEN ACCESSIBLE BOLTS AND CAP SCREWS.	See torque chart below.

STANDARD TORQUE CHART



The torques shown in the chart at right do not apply for self-locking nut or cap screw or when bearing on aluminum or other soft metal.

The types of bolts and cap screws are identified by head markings as follows:

Plain Head : regular machine bolts and cap screws

3-Dash Head: tempered steel high-strength bolts and cap screws.

6-Dash Head: tempered steel extra high-strength bolts and cap screws.

RECOMMENDED TORQUE IN FT.-LBS COARSE AND FINE THREADS			
	B	D	F
			
Bolt Diameter	Plain Head	Three Dashes	Six Dashes
1/4	Not used	10	14
5/16	Not used	20	30
3/8	Not used	35	50
7/16	35	55	80
1/2	55	85	120
9/16	75	130	175
5/8	105	170	240
3/4	185	300	425
7/8	160	445	685
1	250	670	1030
1-1/8	330	910	1460
1-1/4	480	1250	2060

10 General
15-4 Tune-Up and Adjustment

Excavator - JD690
TM-1017 (May-72)

Group 20 LUBRICATION

GENERAL INFORMATION

Detailed and illustrated lubrication instructions are in the operator's manual furnished with your customer's machine. Remind him to follow those instructions carefully.

When servicing the excavator, use the following chart to determine capacities and types of lubricants for each of the various components and systems. A definition of the various lubricants follows the chart.

Component	Capacity	Type of Lubricant
Engine crankcase	16 U.S. quarts 20 qts. (modified dipstick) 15 qts. (690-A) 17 qts. (690-A Engine Serial No. 359844-)	See "Engine Lubricating Oils" on page 20-2.
Hydraulic reservoir	To sight glass	SAE 10W (SC/CC) (MIL-L-2104B)
Return filters (hydraulic oil)
Swing and track gearboxes	7-1/2 quarts - swing 4-1/2 quarts - propel (2)	Shell Omala 72, Mobil Mobilube GX-90 or an equivalent.
Swinging gear*	6-1/2 to 7-1/2 quarts	Texaco "1X" Compound, Shell Cardium EPC Compound or an equivalent.
Swing bearing grease fittings	Shell Alvania "EP-2" or an equivalent.
Grease fittings	John Deere Multi-Purpose Lubricant or an equivalent.
Reservoir and suction filter
Starter	Saturate wicks (3) Lubricate armature shaft splines during assembly	Engine crankcase oil (SAE 10W) Engine crankcase oil (SAE 10W)

**Below 0°F, add 1-1/2 qt. No. 1 diesel fuel to crater compound. Swing slowly 10 minutes to mix. Above 40°, drain and refill with undiluted Cardium Compound EPC or an equivalent.*

LUBRICANTS

Effective use of lubricating oils and greases is perhaps the most important step towards low upkeep cost, long excavator life, and satisfactory service. Use only lubricants specified in this section; apply them at intervals and according to the instructions in the lubrication and periodic service section.

ENGINE LUBRICATING OILS



We recommend John Deere Torq-Gard or Torq-Gard Supreme engine oil for use in the engine crankcase. This oil is compounded specifically for use in John Deere engines, and provides superior lubrication under all conditions. NEVER PUT ADDITIVES IN THE CRANKCASE. Torq-Gard oil is formulated to provide all the protection your engine needs. Additives could reduce this protection rather than help it.

If oil other than Torq-Gard or Torq-Gard Supreme is used, it must conform to the following specifications.

SINGLE VISCOSITY OILS

API Service CD/SD
MIL-L-2104C
Series 3

MULTI-VISCOSITY OILS

API Service CC/SD
MIL-L-46152

Depending on the expected prevailing temperature for the fill period, use oil of viscosity as shown in the following chart.

Air Temperature	John Deere Torq-Gard Oil	Other Oils	
		Single Viscosity	Multi-Viscosity Oil
Above 32° F.	SAE 30	SAE 30	Not recommended.
-10° F. to 32° F.*	SAE 10W-20	SAE 10W	SAE 10W-30
Below -10° F.	SAE 5W-20	SAE 5W	SAE 5W-30

**SAE 5W-20 oil may also be used to insure optimum lubrication at starting, particularly when engine is subjected to -10° F. or lower temperatures for several hours.*

Some increase in oil consumption may be expected when SAE 5W-20 or SAE 5W oils are used. Check oil level more frequently.

HYDRAULIC OIL

Use only SAE 10W oil (API designation SC/CC and military specification Mil-L-2104B). This oil is suitable for all weather conditions.

GREASES

Use John Deere Multi-Purpose Lubricant or an equivalent multipurpose-type grease for all grease fittings unless otherwise indicated. Application of grease as instructed in the lubrication chart will provide proper lubrication and will prevent contamination of bearings.

STORING LUBRICANTS

This excavator can operate efficiently only if clean lubricants are used. Use clean containers to handle all lubricants. Store them in an area protected from dust, moisture, and other contamination.

Group 25 SEPARATION

REMOVING AND INSTALLING ENGINE

REMOVAL

Operate controls to release hydraulic pressure from hydraulic system.

Disconnect battery ground strap.

Swing access fenders away from engine.

Hook a hoist through the air cleaner access door and remove hood assembly.

Lift grille housing at radiator filler cap access door.

Disconnect fuel lines, electrical harness, oil pressure hose, starting aid tube, and throttle linkage.

Disconnect main hydraulic pump and hydraulic oil cooler lines.

Support fuel tanks and disconnect fuel tank-to-engine brackets.

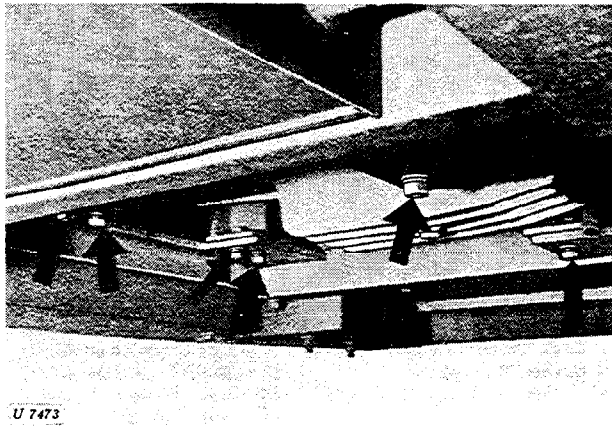
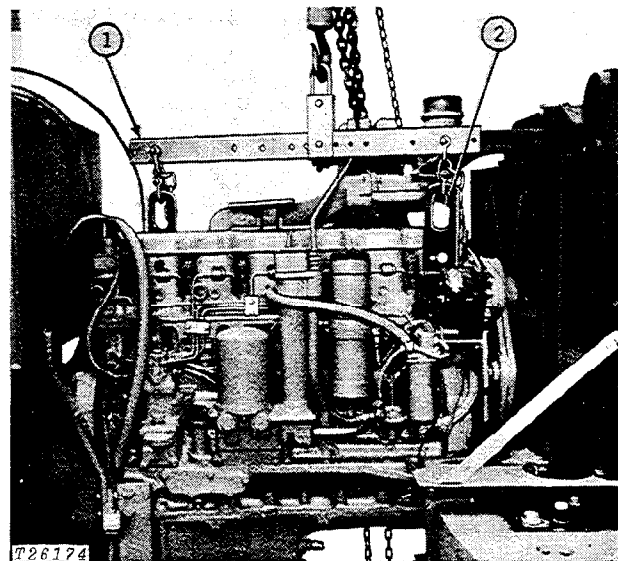

Fig. 1-Engine Attaching Cap Screws
(Early Unit Shown)

Remove cap screws (Fig. 1) securing engine to frame.



1 - Engine Sling (JDG-1) 2 - Lift Eye (JD244)

Fig. 2-Removing Engine

Remove engine (Fig. 2) using hoist and lifting eyes. See "SPECIAL TOOLS, page 10-25-8."

INSTALLATION

Place engine mounts on engine and tighten bolts finger tight.

Set engine on main frame. Shim any engine mounts that do not sit flat on engine mounting plates in main frame as required to remove misalignment. Tighten mounting plate-to-main frame bolts (400 ft-lbs). Tighten engine-to-engine mounting bracket bolts last.

Install and connect all parts removed during engine removal.

Start engine and check fuel lines, hydraulic lines, and radiator hoses for leaks.

REMOVING AND INSTALLING REAR BUMPER

REMOVAL

Operate controls to release hydraulic pressure from hydraulic system.

Disconnect battery ground strap.

Drain radiator and remove grille housing and radiators.

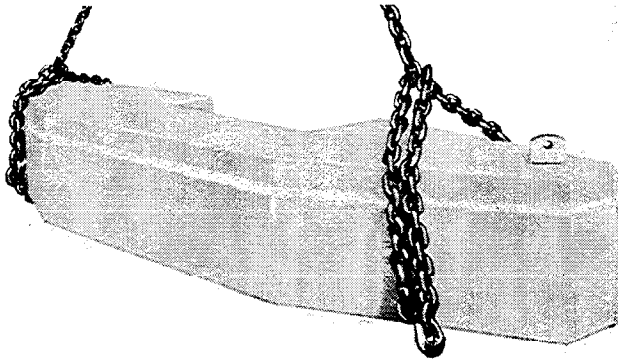

T 19671

Fig. 3—Removing Rear Bumper

Attach chain hoist to either the one piece or three piece bumper as shown and remove unit by pulling bumper rearward.

NOTE: Three piece bumper should be removed as an assembly.

CAUTION: Use care that chain does not slip out from under bumper. Be sure hoist is large enough to lift assembled bumper. See specifications for weight on rear bumper.

The side and center counterweights (Fig. 4) used with the one piece bumper may be removed from rear bumper by placing floor jack under counterweights, removing cap screws and slowly lowering weight from bumper.

CAUTION: Use care that counterweights do not slip off floor jack. See Specifications for weights of counterweights.

INSTALLATION

Install rear bumper assembly using the same CAUTIONS that were outlined during removal.

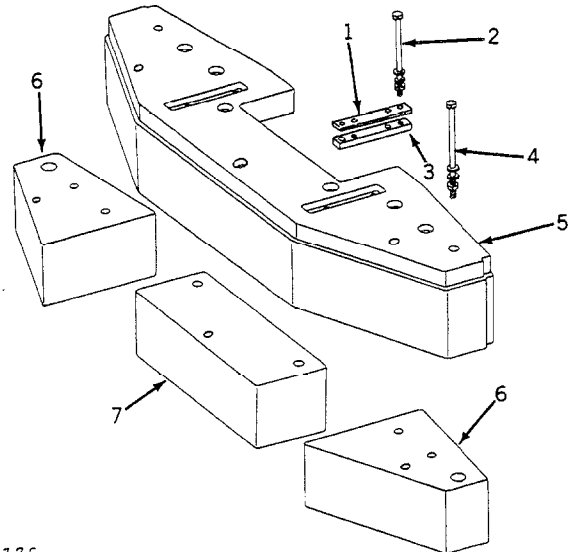

T26176

- 1 - Bumper Shim (2 used)
- 2 - Hex. Bolt (4 used)
- 3 - Anchor Block (4 used)
- 4 - Hex. Bolt (9 used)

- 5 - Rear Bumper
- 6 - Side Counterweight (2 used)
- 7 - Center Counterweight

Fig. 4—Rear Bumper Assembly
(Serial No. 001711)

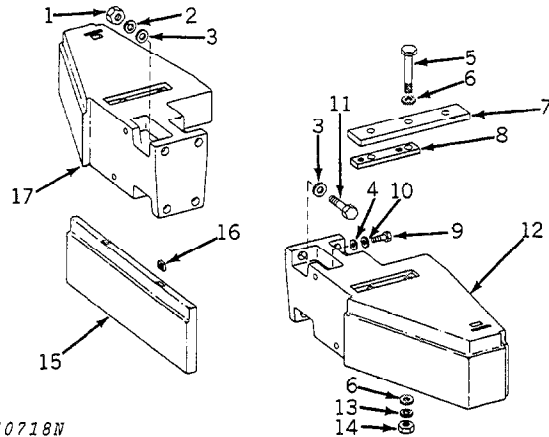

T30718W

- 1 - Nut (4 used)
- 2 - Lock Washer (4 used)
- 3 - Washer (8 used)
- 4 - Washer (4 used)
- 5 - Bolt (9 used)
- 6 - Special Washer (18 used)
- 7 - Bumper Shim (2 used)
- 8 - Anchor Block (4 used)
- 9 - Cap Screw (4 used)

- 10 - Lock Washer (4 used)
- 11 - Cap Screw (4 used)
- 12 - Right Split Bumper
- 13 - Lock Washer (9 used)
- 14 - Nut (9 used)
- 15 - Center Bumper
- 16 - Nut (4 used)
- 17 - Left Split Bumper

Fig. 5—Rear Bumper Assembly
(Serial No. 001712)

REMOVING AND INSTALLING RESERVOIR

REMOVAL

Operate controls to release hydraulic pressure from hydraulic system.

Disconnect battery ground strap.

Swing right access fender away from unit.

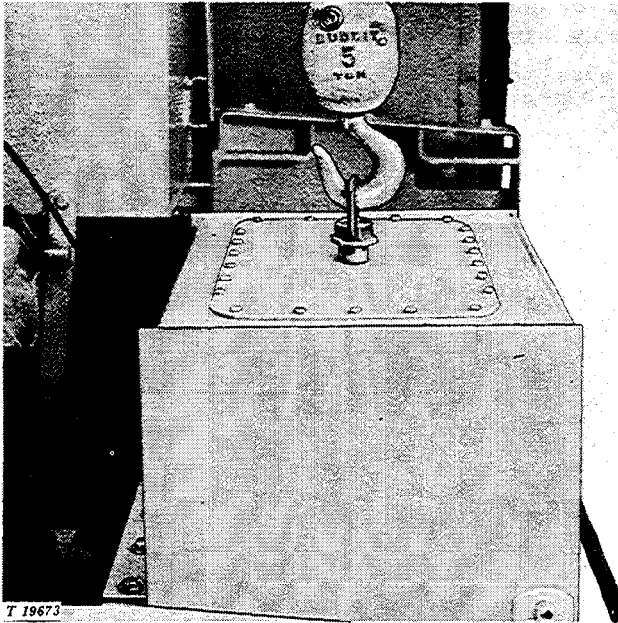

Fig. 6—Removing Reservoir

Drain reservoir and disconnect all hydraulic lines.

Remove attaching cap screws and lift reservoir from unit.

INSTALLATION

Install reservoir and tighten attaching cap screws to 120 ft-lbs.

REMOVING AND INSTALLING FUEL TANK

REMOVAL

Operate controls to release hydraulic pressure from hydraulic system.

Disconnect battery ground strap.

Swing access fenders away from unit. Remove hood and fender extensions from unit.

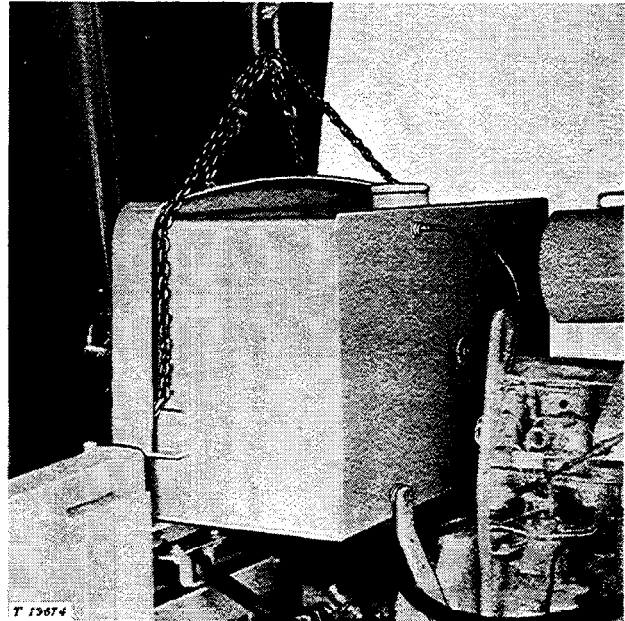

Fig. 7—Removing Fuel Tank

Drain fuel tank and disconnect fuel lines.

Disconnect hydraulic control valve from tank and remove hose guides from bottom of tank.

Remove attaching cap screw and lift fuel tank from unit.

INSTALLATION

Install fuel tank and tighten attaching cap screws to 120 ft-lbs.

REMOVING AND INSTALLING CAB

REMOVAL

Operate controls to release hydraulic pressure from hydraulic system.

Disconnect battery ground strap.

Remove switch panel and cable guide from cab.

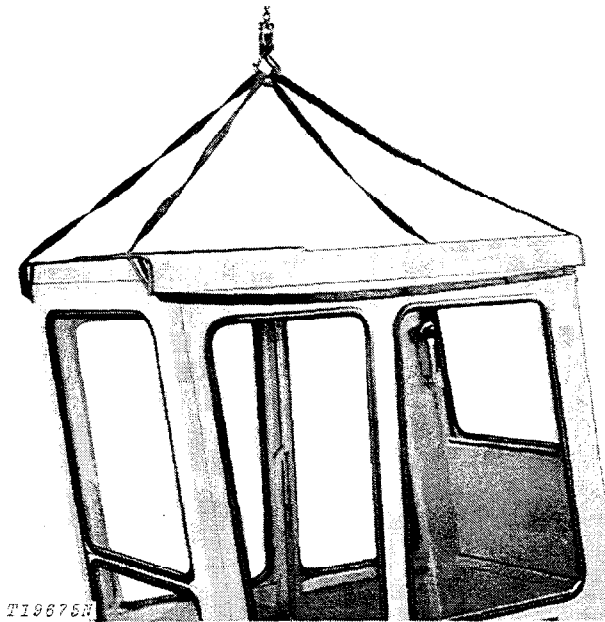

Fig. 8—Removing Cab

Remove cap screws securing cab to platform and lift cab from unit as shown in Fig. 8.

INSTALLATION

Install cab to platform and tighten attaching cap screws to 170 ft-lbs.

REMOVING AND INSTALLING SWING MOTOR

REMOVAL

Align dipperstick parallel with tracks.

Remove hood extension and swing motor cover.

Disconnect and cap swing motor heater and drain lines. Disconnect and cap hydraulic lines from swing motor to control valve.

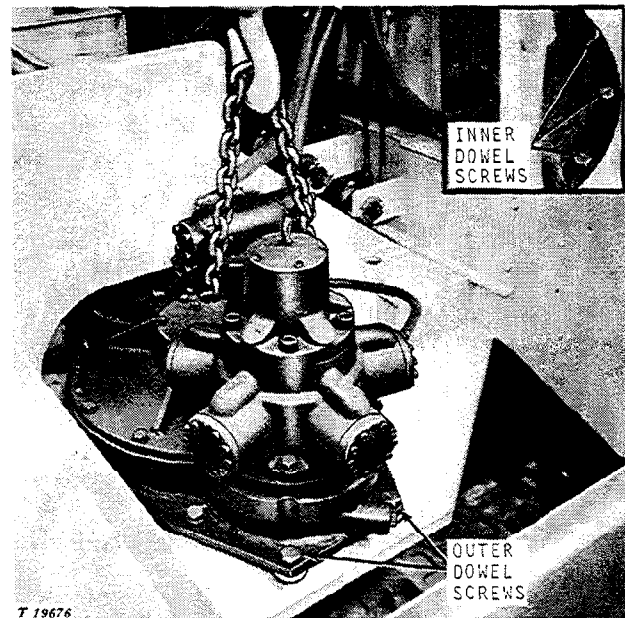

Fig. 9—Removing Swing Motor

Remove regular swing motor gear box assembly to main frame cap screws.

Dowel screws are designed to have heads flame cut off and driven down through main frame. However, screws may be removed after removing hex nuts.

Remove swing motor oil stand pipe.

INSTALLATION

Install swing motor making sure gears mesh properly. Secure motor with dowel screws and hex nuts. Tighten nuts to 445 ft-lbs torque. Install regular cap screws and tighten to 300 ft-lbs torque.

REMOVING AND INSTALLING TRACK MOTORS

REMOVAL

Operate controls to release hydraulic pressure from hydraulic system.

Disconnect battery ground strap.

Drain track motors and disconnect drive chain. Remove protector bar from bottom of undercarriage.

Disconnect brake valve hydraulic lines and remove track motor bleed line.

Position a chain hoist down through the middle of the undercarriage. Place a floor jack under the track motor.

Separate the hydraulic motor assembly (brake valve, rotor valve and motor) as a unit from the reduction gear box.

Remove attaching cap screws and lower track gearbox from unit. The five special dowel cap screws will have to be driven out.

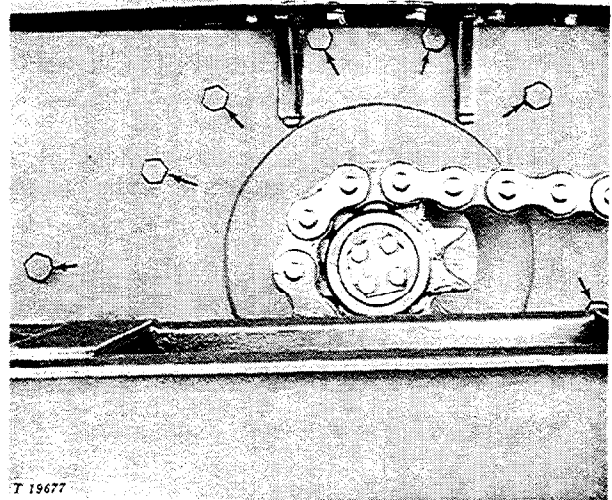

Fig. 10—Track Gearbox Attaching Points

NOTE: Disconnect and remove track assembly to gain added clearance to track motor attaching cap screws.

⚠ CAUTION: Keep out from under track motor during removal.

Lift one side of undercarriage for clearance to remove assemblies.

INSTALLATION

Install track motor by following "Removal" in the reverse order and tighten attaching cap screws.

REMOVING AND INSTALLING UNDERCARRIAGE

REMOVAL

To replace undercarriage assembly, the upper portion of the excavator must be removed.

To accomplish this, swing the upper portion of the excavator at right angles with the undercarriage.

Retract the bucket, dipperstick and boom until bucket is resting on ground. Stop engine and operate controls to release hydraulic pressure from the hydraulic system.

Remove swing motor from excavator.

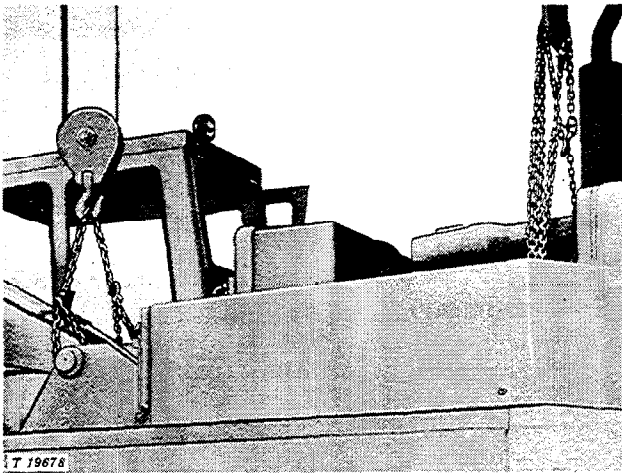

Fig. 11—Removing Upper Portion of Excavator

Attach 5-ton chain hoist at boom pivot.

Attach 10-ton overhead hoist with chains around main frame on each side of engine near rear bumper.

If overhead hoist is not available, place two 10-ton hydraulic jacks under main frame parallel beams near rear bumper.

NOTE: Build crib solidly under hydraulic jacks to reach main frame. Upper portion of excavator will have to be lifted approximately 2

feet for rotary manifold to clear when undercarriage is pulled out.

CAUTION: Do not lift or block under rear bumper.

Disconnect hydraulic lines from rotary manifold.

Remove cap screws securing main frame to undercarriage.

With the aid of hydraulic jacks and hoist, lift the upper portion of the excavator evenly off the undercarriage. Release hydraulic pressure from hydraulic system while lifting.

CAUTION: Keep out from under upper portion of excavator while lifting off undercarriage.

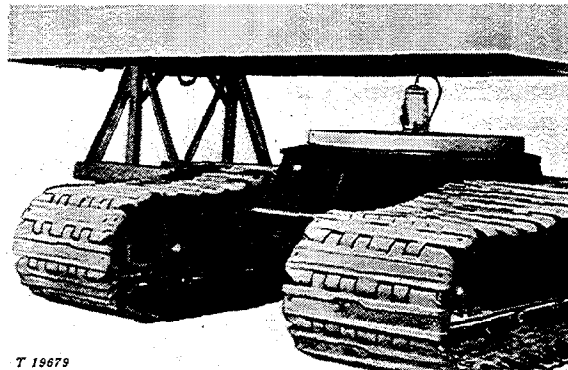

Fig. 12—Removing Undercarriage
(Early Unit Shown)



Disconnect drive chains and pull undercarriage out from under upper portion of excavator.

INSTALLATION

Position undercarriage under upper portion of excavator; lower upper portion evenly.

Outer race of swing bearing should be positioned so that all 35 main frame attaching cap screws may be installed.

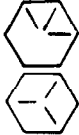
TORQUE CHART

RECOMMENDED TORQUE IN FT.-LBS COARSE AND FINE THREADS			
	B	D	F
			
Bolt Diameter	Plain Head	Three Dashes	Six Dashes
1/4	Not used	10	14
5/16	Not used	20	30
3/8	Not used	35	50
7/16	35	55	80
1/2	55	85	120
9/16	75	130	175
5/8	105	170	240
3/4	185	300	425
7/8	160	445	685
1	250	670	1030
1-1/8	330	910	1460
1-1/4	480	1250	2060

The types of bolts and cap screws are identified by head markings as follows:

Plain Head: (B-strength) regular machine bolts and cap screws.

3-Dash Head: (D-strength) tempered steel high-strength bolts and cap screws.

6-Dash Head: (F-strength) tempered steel extra high-strength bolts and cap screws.

Machine bolts and cap screws 7/8 inch and larger are sometimes formed hot rather than cold, which accounts for the lower torque.

SPECIAL TOOLS

No.	Name	Use
ESSENTIAL TOOLS		
JD244*	Engine Lift Eyes	To remove engine
JDG-1*	Engine Sling	To remove engine

*Order from: Service Tools Inc., 1901 Indiana Avenue, Chicago, Illinois 60616.

Section 20 ENGINE

CONTENTS OF THIS SECTION

	Page		Page
GROUP 5 - DIAGNOSIS		GROUP 20 - SPEED CONTROL LINKAGE	
Diagnosing Basic Engine Malfunctions	5-2	Speed Control Adjustments	20-1
GROUP 10 - BASIC ENGINE		GROUP 25 - ENGINE COOLING SYSTEM	
Head Assembly	10-2	Diagnosing Malfunctions	25-1
Block, Liners, Pistons, and Rods . . .	10-5	Radiator	25-1
Crankshaft, Main Bearings, and Fly- wheel	10-9	Crankcase Oil Cooler	25-2
Camshaft	10-12	Water Pump	25-3
GROUP 15 - ENGINE LUBRICATION		GROUP 30 - SPECIFICATIONS AND SPECIAL TOOLS	
Oil Pump and Filter	15-1	Basic Engine	30-1
Testing	15-1	Engine Lubrication	30-6
Diagnosing Malfunctions	15-2	Speed Control Linkage	30-7
Repair		Engine Cooling	30-8
Pump	15-2		
Oil Filter Housing	15-3		



Suggest:

If the above button click is invalid.

Please download this document

first, and then click the above link

to download the complete manual.

Thank you so much for reading

Group 5 DIAGNOSIS

GENERAL INFORMATION

The engine is a 6-cylinder, valve-in-head, vertical in-line, four-cycle engine.



For basic theory of engine operation see the FOS-30 "Engines" manual.

DIAGNOSING ENGINE MALFUNCTIONS

WILL NOT START

Electrical System Malfunction-See Section 40

- Weak battery.
- Faulty or loose wiring.
- Faulty key switch.
- Faulty safety start switches.
- Faulty fuel shut off solenoid.

Fuel System Malfunction-See Section 30

- Foreign matter in fuel system.
- Faulty fuel pump.
- Incorrect engine timing.
- Faulty fuel injection pump.
- Faulty fuel injectors.
- Improper fuel.
- Fuel shut-off at tank.
- Restricted air intake system.
- Plugged fuel filter.

UNEVEN RUNNING OR FREQUENT STALLING

Fuel System Malfunction-See Section 30

- Low fuel supply.
- Faulty or leaking fuel injector tips.
- Fuel filter or lines restricted.
- Faulty fuel pump.
- Exhaust system restricted.
- Faulty fuel injection pump.

ENGINE MISSES

Fuel System Malfunction-See Section 30

- Water in fuel.
- Air in fuel system.
- Faulty fuel injection nozzles.
- Faulty fuel injection pump.
- Fuel injection nozzle improperly installed.
- Fuel injection nozzle gasket leaking.
- Worn or faulty fuel pump.
- Detonation or pre-ignition.

LACK OF POWER

Incorrect service-See Section 10

- Wrong viscosity crankcase oil.

Fuel System Malfunction-See Section 30

- Dirty or obstructed air cleaners.
- Restricted air intake passage.
- Sub.-standard fuel.
- Fuel filter restricted.
- Faulty fuel pump.
- Faulty fuel injection pump.
- Faulty fuel injectors.
- Obstructed fuel line.

Power Train Malfunction-See Section 50

- Clutch slipping.

ENGINE OVERHEATS

Incorrect Service-See Section 10

- Engine overloaded.
- Crankcase oil level low.
- Clean radiator.

<https://www.ebooklibonline.com>

Hello dear friend!

Thank you very much for reading.

Enter the link into your browser.

The full manual is available for immediate download.

<https://www.ebooklibonline.com>