

# John Deere 670A and 672A Motor Grader Repair



**TECHNICAL MANUAL**

TM-1188 (Dee-87)

LITHO IN U.S.A.

# JD670-A AND JD672-A MOTOR GRADERS

Technical Manual  
TM-1188 (Dec-87)

## SECTION AND GROUP CONTENTS

### SECTION I - GENERAL INFORMATION

- Group I - Contents (not used)
- Group II - Introduction and Safety Information
- Group III - General Specifications
- Group IV - Predelivery, Delivery and After-Sales Services
- Group V - Lubrication

### SECTION 1 - WHEELS

- Group 0110 - Powered Wheels and Fastenings
- Group 0120 - Non-Powered Wheels and Fastenings
- Group 0199 - Specifications and Special Tools

### SECTION 2 - AXLES AND SUSPENSION SYSTEMS

- Group 0201 - Drive Axle Housing and Support
- Group 0210 - Differential or Bevel Drive
- Group 0250 - Axle Shafts, Bearing and Reduction Gears
- Group 0260 - Hydraulic System
- Group 0299 - Specifications and Special Tools

### SECTION 3 - TRANSMISSION

- Group 0315 - Controls
- Group 0341 - Housings and Covers
- Group 0350 - Gears, Shafts, Bearings and Power Shift Clutch
- Group 0360 - Hydraulic System
- Group 0370 - Clutch Disconnect and Controls
- Group 0399 - Specifications and Special Tools

### SECTION 4 - ENGINE

- Group 0400 - Removal and Installation
- Group 0422 - Starting Motor and Fastenings
- Group 0499 - Specifications and Special Tools

### SECTION 5 - ENGINE AUXILIARY SYSTEMS

- Group 0505 - Cold Weather Starting Aids
- Group 0510 - Cooling Systems
- Group 0515 - Speed Controls
- Group 0520 - Intake System
- Group 0540 - Mounting Frame
- Group 0560 - External Fuel Supply Systems
- Group 0599 - Specifications and Special Tools

### SECTION 8 - TRANSFER DRIVE

- Group 0841 - Housings and Covers
- Group 0851 - Gears, Shafts, Bearings
- Group 0899 - Specifications and Special Tools

### SECTION 9 - STEERING SYSTEM

- Group 0920 - Power Steering
- Group 0960 - Hydraulic System
- Group 0999 - Specifications and Special Tools

### SECTION 10 - SERVICE BRAKES

- Group 1011 - Active Elements
- Group 1015 - Controls Linkage
- Group 1060 - Hydraulic System
- Group 1099 - Specifications and Special Tools

### SECTION 11 - PARKING-EMERGENCY BRAKES

- Group 1111 - Active Elements
- Group 1115 - Controls Linkage
- Group 1199 - Specifications and Special Tools

### SECTION 15 - EQUIPMENT ATTACHING

- Group 1511 - Drawbar
- Group 1599 - Specifications and Special Tools

*Continued on next page*

*All information, illustrations and specifications contained in this technical manual are based on the latest information available at the time of publication. The right is reserved to make changes at any time without notice.*

Copyright© 1987  
DEERE & COMPANY  
Moline, Illinois  
All Rights Reserved

**SECTION 16 - ELECTRICAL SYSTEMS**

- Group 1671 - Batteries, Support and Cables
- Group 1672 - Alternator, Regulator and Charging System Wiring
- Group 1673 - Lighting System
- Group 1674 - Wiring Harness and Switches
- Group 1675 - System Controls
- Group 1676 - Instruments and Indicators
- Group 1699 - Specifications and Special Tools

**SECTION 17 - FRAME, CHASSIS OR SUPPORTING STRUCTURE**

- Group 1740 - Frame Installation
- Group 1746 - Frame Bottom Guards
- Group 1747 - Bumpers, Vehicle
- Group 1799 - Specifications and Special Tools

**SECTION 18 - OPERATOR'S STATION**

- Group 1810 - Operator Enclosure
- Group 1821 - Seat and Seat Belt
- Group 1822 - Steps and Handholds
- Group 1830 - Heating and Air Conditioning
- Group 1899 - Specifications and Special Tools

**SECTION 19 - SHEET METAL AND STYLING**

- Group 1910 - Hood or Engine Enclosure
- Group 1913 - Miscellaneous Shields
- Group 1921 - Grille and Grille Housing

**SECTION 20 - SAFETY, CONVENIENCE AND MISCELLANEOUS**

- Group 2002 - Mirror
- Group 2003 - Fire Extinguisher
- Group 2004 - Horn
- Group 2006 - Cigar Lighter

**SECTION 21 - MAIN HYDRAULIC SYSTEM**

- Group 2160 - Hydraulic System
- Group 2199 - Specifications and Special Tools

**SECTION 34 - GRADING DEVICE**

- Group 3401 - Blade
- Group 3415 - Controls Linkage
- Group 3440 - Frames
- Group 3450 - Circle Gear Box
- Group 3460 - Hydraulic System
- Group 3499 - Specifications and Special Tools

**SECTION 42 - GROUND CONDITIONING TOOL**

- Group 4201 - Blades, Teeth, Shanks, Etc.
- Group 4215 - Controls Linkage
- Group 4240 - Frames
- Group 4260 - Hydraulic System
- Group 4299 - Specifications and Special Tools

**<https://www.ebooklibonline.com>**

Hello dear friend!

Thank you very much for reading.

Enter the link into your browser.

The full manual is available for immediate download.

**<https://www.ebooklibonline.com>**

## Group II

# INTRODUCTION AND SAFETY INFORMATION

## INTRODUCTION

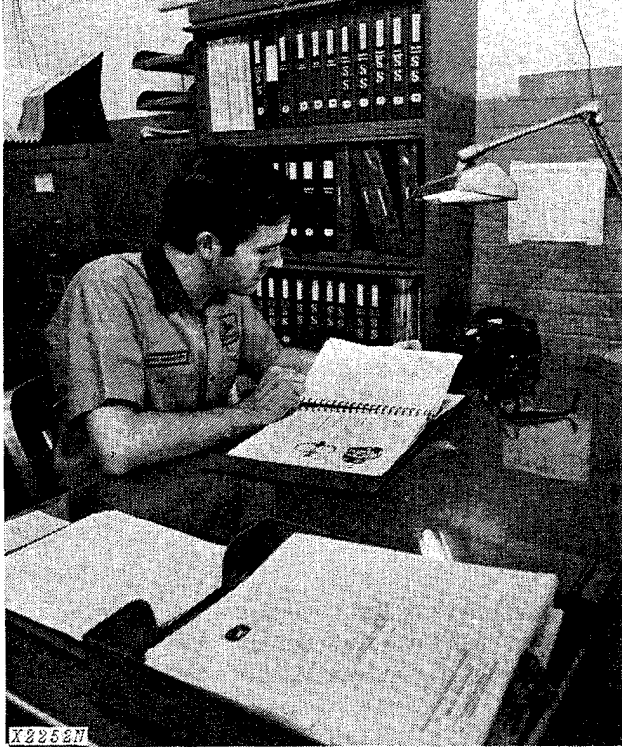

Use FOS Manuals for Reference

This technical manual is part of a twin concept of service:

The two kinds of manuals work as a team to give you both the general background and technical details of shop service.

### •FOS Manuals - For Reference

Fundamentals of Service (FOS) Manuals cover basic theory of operation, fundamentals of troubleshooting, general maintenance, and basic types of failure and their causes. FOS Manuals are for training new personnel and for reference by experienced service technicians.



When a service technician should refer to a FOS Manual for more information, a FOS symbol like the one at the left is used in the technical manual.

### •Technical Manuals - For Actual Service

Technical manuals are concise service guides for specific machines. Technical manuals are on-the-job guides containing only the vital information needed by an experienced service technician.



Use Technical Manuals for Actual Service

This technical manual was written for you - an experienced service technician. Keep it in a permanent binder in the shop where it is handy. Read it when you need to know correct service procedures or specifications.

Some features of this manual:

- Inside front cover - "Table of Contents".
- Section I - General specifications and services.
- Sections 1 through 46 - Removal, repair, testing (components removed), installation, and adjustment.
- Section 90 - Detailed explanation of system operation, diagnosis, visual inspection, testing, and adjustments.
- Specifications are listed and illustrated at the end of each section.

# MAINTENANCE WITHOUT ACCIDENT WORK SAFELY



T27999N

 This safety symbol is used for important safety messages. When you see this symbol, follow the safety message to avoid personal injury.

**EVERY EMPLOYER HAS A  
SAFETY PROGRAM. KNOW  
WHAT IT IS!**

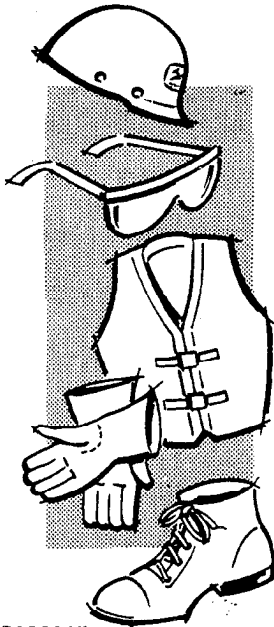

T27501N

See your shop supervisor for specific instructions on a job, and the safety equipment required.

For instance, you may need: Hard hat, safety shoes, safety goggles, heavy gloves, reflector vest, ear protectors, respirator.



## BE ALERT!

Plan ahead—work safely—know how to use a first-aid kit and a fire extinguisher—and where to get assistance.

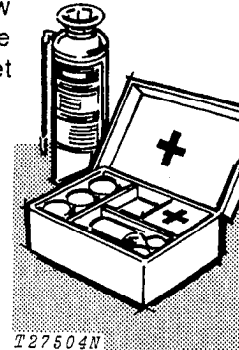

T27504N

## Maintenance Area

Make sure the maintenance area has enough ventilation.

Keep the maintenance area **CLEAN AND DRY**. Oily and wet floors are slippery. Greasy rags are a fire hazard. Wet spots are dangerous when working with electrical equipment.

Keep starting aids in a cool, well-ventilated place, out of reach of unauthorized personnel.

## MAINTENANCE WITHOUT ACCIDENT

### AVOID FIRE HAZARDS—

#### Fuel Is Dangerous!

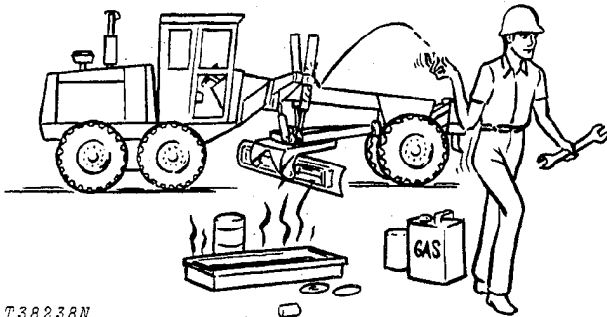

T38238N

Do not smoke while putting fuel in the fuel tank.

Do not smoke while working with material that will start on fire easily.

Stop the engine before filling the fuel tank.

If the engine is hot, use care when putting fuel in the fuel tank.

Do not use gasoline or diesel fuel for cleaning parts. Use solvents that will not start on fire.

#### Battery Gas Is Highly Flammable!

When charging batteries, be sure there is enough ventilation.



T27506N

Do not check the battery charge by putting metal objects across the posts.

Do not let sparks or open flame near batteries.

Do not smoke near battery.

#### Flame Is Not a Flashlight!

**NEVER USE OPEN FLAME AROUND THE MACHINE.**

**KNOW WHERE FIRE EXTINGUISHERS ARE KEPT!**

Litho in U.S.A.

### UNDER ALL MAINTENANCE CONDITIONS—

Do not work on the equipment unless you are approved to do so. Then be sure you know the safe and correct procedure.

Never work on equipment while it is being operated.

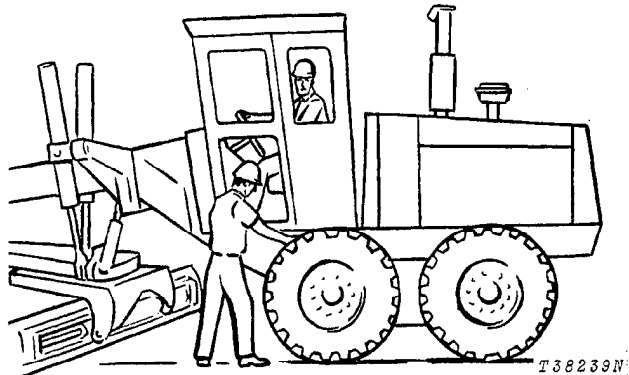

T38239N

When the engine is running, avoid working on equipment.

If you must work on the machine with the engine running, ALWAYS USE TWO service technicians. One must be at the controls. The other must be within sight of the operator.

### KEEP HANDS AWAY FROM MOVING PARTS

Put a support under all raised equipment.

Never work under a raised blade, ripper, or scarifier.

Lower all equipment to the ground.

If the machine is on a slope, use blocks to hold it in place.

Do not lift heavy parts by yourself. Use hoisting equipment for this.

### TAKE CARE! WATCH OUT FOR OTHER PEOPLE IN THE AREA

When drilling, grinding, or hammering metal, wear safety glasses.

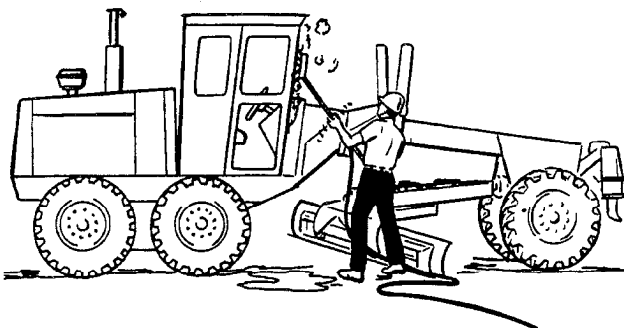
**BE CAREFUL DURING SERVICE  
AND REPAIR**

T38242N

Keep ALL equipment free of dirt and oil.

Clean oil, grease, mud, ice or snow from the operator's station, steps and hand rails.

When getting the engine ready for storage, remember that inhibitor changes easily into gas and is dangerous. After adding the inhibitor, seal and tape openings. When you are not using the inhibitor, keep the can tightly closed.

Do not remove the radiator cap unless you can hold your hand on the radiator tank. First, loosen the cap slowly to the stop. Then release all pressure in the cooling system before removing the cap.

Check the exhaust system regularly for leaks.

Release hydraulic pressure before working on the hydraulic system. Stop the engine. Lower all equipment to the ground. Move the control levers until the equipment does not move.

When checking hydraulic pressure, be sure to use the correct test gauge.

Before working on the fuel system, close the fuel shutoff valve.

Before working on the electrical system, or making a major overhaul, disconnect the batteries.

**KNOW EQUIPMENT IS READY!**

Check all guards, shields, and safety bars. Every one must be in place and tight.

**CHECK IT OUT!**

- GUARDS
- SHIELDS
- SAFETY BARS
- ROLL-OVER PROTECTIVE STRUCTURES
- SEAT BELTS, ETC.

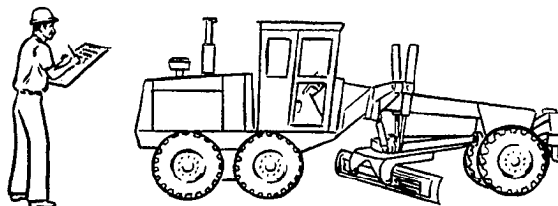

T38243N

Carefully inspect all systems for leaks.

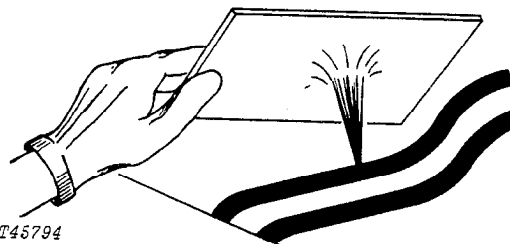

T45794

Use a piece of cardboard or wood, rather than hands, to search for suspected leaks.

Escaping fluid under pressure can penetrate the skin.

If injured by escaping fluid, see a doctor at once.

## Group III

# GENERAL SPECIFICATIONS

(Specifications and design subject to change without notice. Wherever applicable, specifications are in accordance with ICED and SAE Standards. Except where otherwise noted, these specifications are based on a unit equipped with 13.00-24, 12 ply rating, tubeless tires, 12 ft. (3.66 m) moldboard, and standard equipment. Weights include lubricants, coolants, full fuel tank and 175 lb. (79 kg) operator.)

### Power

(at 2300 engine rpm):	<b>SAE</b>	<b>DIN</b>
Gross .....	135 hp (100.7 kW)	
Net .....	125 hp (93.2 kW)	126.7 PS

Net engine flywheel power is for an engine equipped with fan, air cleaner, water pump, lubricating oil pump, fuel pump, alternator, and muffler. The gross engine power is without fan. Flywheel power ratings are under SAE standard conditions of 500 ft. altitude and 85°F temperature, and DIN 70 020 conditions (non-corrected). No derating is required up to 10,000 ft. (3000 m) altitude.

**Engine:** John Deere turbocharged diesel, vertical 6-cylinder, valve-in-head, 4-stroke cycle.

Bore and stroke ..... 4.19x5 in. (106.5x127 mm)

Piston displacement ..... 414 cu. in. (6784 cm<sup>3</sup>)

Compression ratio ..... 16.2 to 1

Maximum torque @ 1300 rpm ..372 lb.-ft. (504 Nm)  
 (51.4 kg/m)

NACC or AMA (U.S. Tax) horsepower ..... 42.1

Main bearings ..... 7

Lubrication ..... Pressure system w/full-flow filter

Cooling . Pressurized, w/thermostat and fixed bypass

Fan ..... Suction

Air cleaner w/restriction indicator ..... Dry

Electrical system ..... 24 volt w/alternator

Batteries (2) 12 volt. . Reserve capacity: 180 minutes

**Transmission** ..... Direct drive full Power Shift with planetary gear reductions. Foot inching pedal.

### Travel Speeds (2300 engine rpm, no tire slip):

Shift Lever Position	Forward		Reverse	
	mph	km/h	mph	km/h
1	2.3	3.6	2.8	4.5
2	3.2	5.1	3.9	6.3
3	4.8	7.8	5.9	9.5
4	6.3	10.1	7.6	12.3
5	8.2	13.2		
6	10.5	17.0		
7	14.1	22.8		
8	23.9	38.4		

**Differential Lock** ..... Foot-operated, hydraulically actuated

### Front Drive: (JD672-A only)

Hydrostatic motor in each wheel controlled through a flow divider to provide optimum traction. Free-wheeling in gears 5 through 8. Switch controlled for two modes of operation.

Pump ..... 5.43 cu. in. (89 cm<sup>3</sup>) variable displacement pump driving a 2.03 cu. in. (33 cm<sup>3</sup>) reversible motor in each wheel.

**Rear Drive** . . . Inboard planetary final drives with heat-treated, splined steel torque shafts. Oscillating welded construction tandems; nodular cast sprockets driving 2 in. (51 mm) pitch roller chain in oil bath.

**Front Axle:** Fabricated steel box-frame with steel spindles  
 Total oscillation . . . . . 30 deg.  
 Wheel lean range (either direction) . . . . . 20 deg.

**Steering:**  
 Front . . . Full hydraulic power system. Steering capabilities without power  
 Rear . . . Hydraulically articulated frame steering (25 deg. left or right)  
 Minimum turning radius  
 (JD670-A) . . . . . 22 ft. (6.7 m)  
 Minimum turning radius  
 (JD672-A) . . . . . 22 ft. 6 in. (6.86 m)

**Brakes:**  
 Service . . . Foot-operated, hydraulically-actuated, wet-disk, effective on 4 tandem wheels  
 Parking . . . . . Foot-operated, mechanical, dry-disk, effective on 4 tandem wheels  
 Hydraulic System: Closed-center  
 Pressure controlled variable-displacement pump . . . 35 gpm (132 L/min) @ 2300 engine rpm

**Blade:**  
 Length . . . . . 12 ft. (3.66 m)  
 Height . . . . . 24 in. (610 mm)  
 Thickness . . . . . 0.88 in. (22 m)

**Blade Range:**  
 Lift above ground . . . . . 1 ft. 4.10 in. (409 mm)  
 Blade side shift:  
 Right or left . . . . . 2 ft. 2.9 in. (683 mm)  
 Shoulder reach outside wheels:  
 Right or left . . . . . 7 ft. (2.13 m)  
 Pitch at ground line . . . . . 44 deg. forward  
 10 deg. back

**Blade Lifting Mechanism:**  
 Control . . . . . Dual-lever, hydraulic w/float position

**Lift Arms:** Nodular cast  
 Positions . . . . . 7  
 Control . . . . . Hydraulic, foot operated

**Circle:** Fabricated steel angle construction  
 Circle diameter . . . . . 4 ft. 10 in. (1.47 m)  
 Rotation . . . . . 360 deg.  
 Drive . . . Hydraulic motor and worm gear w/positive position lock  
 Sideshift, right and left . . . . . 31.2 in. (792 mm)

**Drawbar** . . . . . Welded box section, 3.5x7x0.5 in. (89x178x13 mm) wall w/ball and socket draft connection

**Frame:**  
 Rear main frame . . . Welded box section, from articulation joint to main frame arch  
 Width, minimum . . . . . 9.25 in. (235 mm)  
 Height, minimum . . . . . 14.65 in. (372 mm)  
 Thickness, sides . . . . . 0.63 in. (16 mm)  
 top and bottom (min.) . . . 0.75 in. (19 mm)  
 Weight per ft. (m), minimum . . . 110 lb. (164 kg/m)  
 Minimum vertical section modulus . . 125 inches cubed (2050 cm cubed)  
 Front main frame . . . Welded box section from main frame arch to front hood  
 Width . . . . . 10 in. (254 mm)  
 Height, minimum . . . . . 13 in. (330 mm)  
 Thickness, minimum . . . . . 0.50 in. (13 mm)  
 Weight per ft. (m), minimum . . . 110 lb. (164 kg/m)  
 Minimum vertical section modulus . . 109 inches cubed (1786 cm cubed)

<b>Capacities:</b>	<b>U.S.</b>	<b>Imp.</b>	<b>Liters</b>
Fuel tank . . . . .	60 gal.	50.0 gal.	227
Cooling system . . . . .	7 gal.	5.8 gal.	26.5
Engine lubrication, including filter . . . . .	20 qt.	16.7 qt.	18.9
Transmission case . . . . .	14 gal.	12 gal.	53
Transmission and hydraulic system . . . . .	28 gal.	23.3 gal.	106
(JD670-A)			
Transmission and hydraulic system . . . . .	38 gal.	32 gal.	144
(JD672-A)			
Tandem housings (each) . . .	4 gal.	3.3 gal.	15.1
Worm gearbox . . . . .	3 qt.	2.5 qt.	2.8

**Additional Standard Equipment:**

- |  |   |
|--|---|
| Transistorized voltage regulator             | Gauges:                                   |
| Lights (2 white front w/stop and tail light) | Water temperature                         |
| Work lights (2 front and 2 rear floods)      | Transmission temperature                  |
| Turn signals                                 | Transmission lube pressure                |
| Horn   | Transmission pressure                     |
| Deluxe suspension seat                       | Engine oil pressure                       |
| Mechanical hour meter                        | Fuel                                      |
| Cold weather starting aid                    | Indicators:                               |
| Precleaner                                   | All-wheel drive charge pressure (JD672-A) |
| Engine side shields                          | Air filter                                |
| ROPS cab w/seat belt                         | Transmission filter                       |
| Front and rear windshield wipers             | All-wheel drive filter (JD672-A)          |
| Floor mat                                    |   |

**Dimensions:**

Tire Size	Wheel Tread		Width		Ground Clearance (Front Axle)
	Front	Rear	Front	Rear	
13.00-24	76.60 in. (1.94 m)	79.61 in. (2.02 m)	7 ft. 10 in. (2.34 m)	7 ft. 10 in. (2.34 m)	1 ft. 10 in. (559 mm)
14.00-24	76.60 in. (1.94 m)	79.61 in. (2.02 m)	8 ft. (2.44 m)	8 ft. (2.44 m)	1 ft. 10.5 in. (571 mm)
17.5-25	79.36 in. (2.01 m)	82.37 in. (2.09 m)	8 ft. 6 in. (2.59 m)	8 ft. 6 in. (2.59 m)	1 ft. 11.2 in. (589 mm)

Height to top of steering wheel . . . 7 ft. 4.4 in. (2.25 m)

**Scarifier (Special Equipment):**

V-type for 4 ft. (1.22 m) cut with 3 manual pitch positions and hydraulic float  
 Number of teeth (9 possible) . . . . . 5  
 Lift above ground . . . . . 1 ft. 10 in. (559 mm)  
 Penetration . . . . . 12 in. (305 mm)  
 Shank size . . . . . 1.25x4 in. (31.7x102 mm)

**Ripper (Special Equipment):** 8 ft. (2.44 m) cut width, parallelogram linkage, 2 manual shank vertical positions

Number of shank pockets . . . . . 5  
 Number of shanks . . . . . 3  
 Lift above ground . . . . . 1 ft. 2.5 in. (368 mm)  
 Penetration . . . . . 1 ft. 2 in. (356 mm)  
 Shank size . . . . . 2x5 in. (51x127 mm)  
 Lift above ground (shanks in upper position) . . . . . 1 ft. 11.5 in. (597 mm)

**JD670-A**

SAE Operating Weight	On Front Wheels	On Rear Wheels	Total
Standard equipment . . . . .	7728 lb. (3 505 kg)	18,252 lb. (8 279 kg)	25,980 lb. (11 784 kg)
Standard equipment and scarifier . . . . .	8828 lb. (4 004 kg)	18,252 lb. (8 279 kg)	27,080 lb. (12 283 kg)
Standard equipment, scarifier and ripper . . . . .	8031 lb. (3 643 kg)	21,549 lb. (9 775 kg)	29,580 lb. (13 418 kg)

**JD672-A**

SAE Operating Weight	On Front Wheels	On Rear Wheels	Total
Standard equipment . . . . .	8568 lb. (3 886 kg)	18,507 lb. (8 395 kg)	27,075 lb. (12 281 kg)
Standard equipment and scarifier . . . . .	9668 lb. (4 385 kg)	18,507 lb. (8 395 kg)	28,175 lb. (12 780 kg)
Standard equipment, scarifier and ripper . . . . .	8871 lb. (4 024 kg)	21,804 lb. (9 890 kg)	30,675 lb. (13 914 kg)

**Tires:**

- 13.00-24, 8 or 12 ply rating; 8 in. rim
- 14.00-24, 10 or 12 ply rating; 8 or 10 in. rim
- 17.5-25, 12 ply rating; 14 in. rim

**Special Equipment:**

- |  |                                     |
|--|-------------------------------------|
| Scarifier  | Overlay end bits                    |
| Heavy-duty scarifier                               | Transmission bottom guard           |
| Below-cab blade lights                             | Heavy-duty bottom guard w/drawbar   |
| Bench seat   | Rear-mounted ripper w/drawbar hitch |
| Cab heater (40,000 BTU)                            | Drawbar hitch                       |
| Cab heater (19,000 BTU)                            | Toolbox                             |
| Cab defroster fan                                  | Articulation indicator              |
| Air conditioning w/50 amp heavy-duty alternator    | Engine disconnect                   |
| Roof-mounted heater (w/air conditioner only)       | Reverse warning system              |
| Outside rear view mirrors                          | Sound-baffled engine side shields   |
| ROPS canopy w/seat belt                            | 3 in. seat belt                     |
| Coolant heater                                     | Heavy-duty cutting edge             |
| 2 ft. (610 mm) moldboard extensions, right or left | Automatic blade control             |
| 13 ft. (3.96 m) and 14 ft. (4.27 m) moldboards     |                                     |

### DIMENSIONS

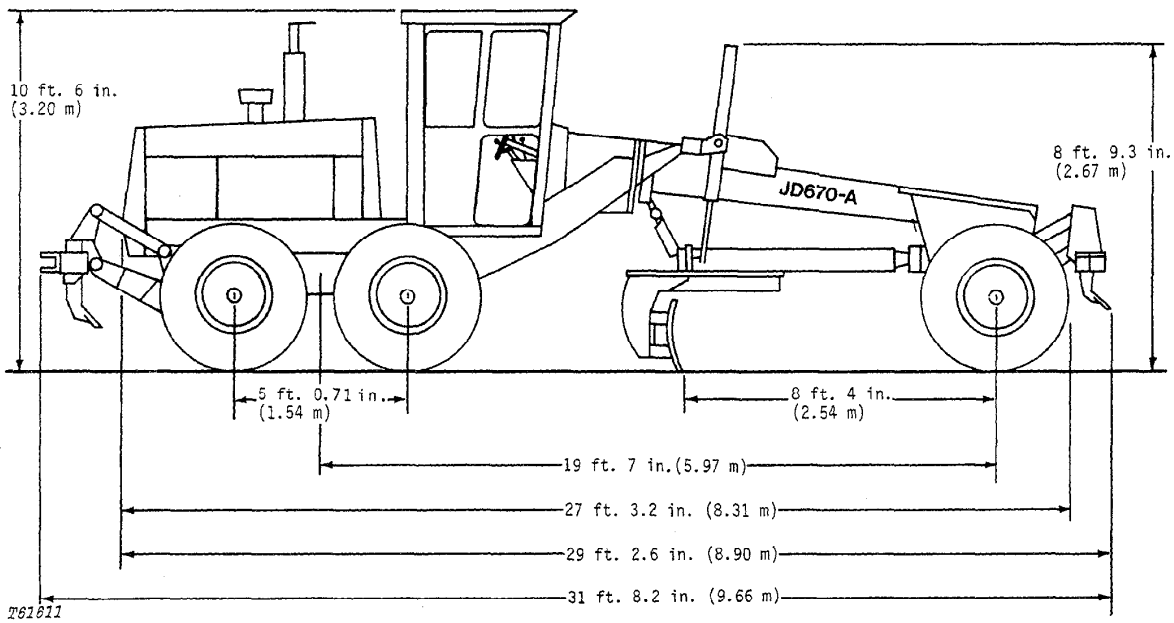

*NOTE: Dimensions for the JD672-A are the same as those shown above. When a motor grader has air conditioning, the height is 10 ft. 7 in. (3.23 m).*

## Group IV PREDELIVERY, DELIVERY, AND AFTER-SALE SERVICES

### TEMPORARY GRADER STORAGE

After receiving your grader from the factory and before putting the machine into temporary storage, perform the following checks.

1. Check the battery electrolyte level. Charge the battery, if necessary.
2. Check the level of the coolant in the radiator. The coolant must be 4 in. (102 mm) below the top of the filler neck.
3. Fill the fuel tank.
4. Check the crankcase oil level. Oil must be between marks on the dipstick after the engine has been stopped for 10 minutes.
5. Relieve hydraulic pressure by lowering the blade, stopping the engine and operating the hydraulic control levers until no equipment moves.

### PREDELIVERY SERVICE

The service technician must carefully check and service the machine before the dealer delivers it to the customer. When the customer receives a machine that is correctly prepared, the customer is well-satisfied. For these reasons, correct predelivery service is very important to the dealer and the customer.

Use the following check list when getting a unit ready for delivery to the customer.

#### 1. Cab Equipment

Check the operation of doors, windows, seat belts, horn, defroster fan, dome light, wipers, heater, etc.

Check air conditioner controls.

**NOTE:** Air temperature must be 60°F (16°C) or higher.

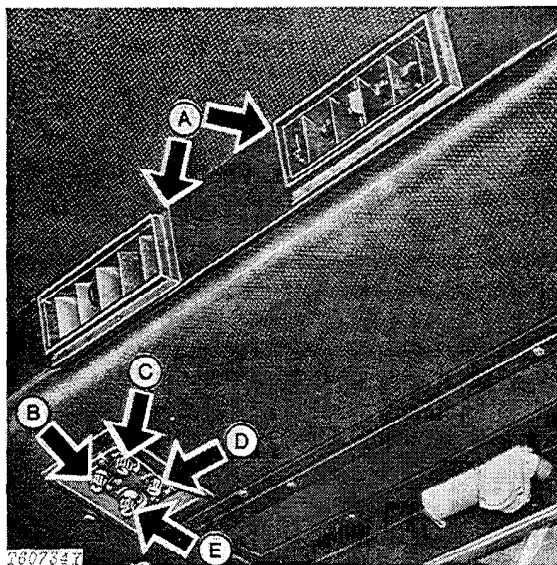

A—Louvers  
B—Recirculating Air Control  
C—Heat Control Knob  
D—Cooling Control Knob  
E—Blower Control Knob

Fig. 1—Air Conditioner Controls

1 - Turn key switch ON. Operate the blower control knob (E) in all positions. Check the fan speeds and air volume from the louvers (A).

2 - Turn the key and blower switches ON. Turn the cooling control knob (D) clockwise toward maximum cooling. Listen for the click from the compressor clutch.



Fig. 2—Heater Valve

3 - Turn the heater valve (Fig. 2) clockwise to closed position.

4 - Turn the blower control knob clockwise to high speed. Turn the cooling control knob clockwise to maximum cooling. Run the engine at approximately 2000 rpm.

5 - After ten minutes check sight glass for bubbles. The sight glass is on the receiver-dryer in the engine compartment next to the compressor.

*NOTE: Bubbles may be seen immediately after the compressor cycles ON. If bubbles are seen under any other condition, see Section 90, Group 9031.*

6 - Check the temperature of air from louvers. Hold a thermometer in louver until you get the lowest reading.

When air temperature is above 80°F (27°C), the temperature of air from louvers must be 25°-30°F (14°-17°C) lower.

When air temperature is below 80°F (27°C), the temperature of air from louvers must be less than 50°F (10°C).

7 - When the unit does not operate correctly, see Section 90, Group 9031.

C - Weight adjustment tube - Sit on the seat. Turn knob B until the yellow pointer inside the tube is flush with tube.

D - Forward and rearward adjustment lever - Move the lever outward to the left (L.H.). Move the seat forward or rearward to the desired position. Release the lever.

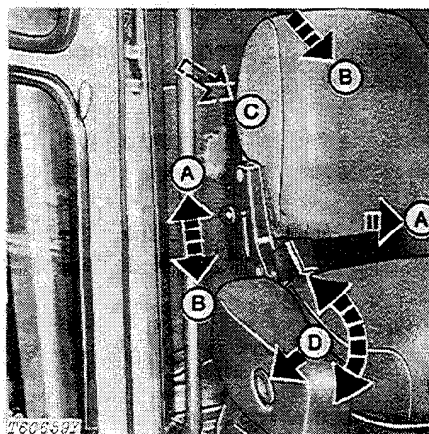

Fig. 4 - Cab Seat Controls

A - Backrest tilt knob - Lift the knob to tilt the bottom of the backrest forward.

B - Lower the knob to tilt the top of the backrest forward.

C - Backrest knob - Raise the knob for a soft backrest. Lower the knob for a firm backrest.

D - Armrest button - Hold the button in. Move the armrest up or down to the desired position. Release the button. The armrest will latch in four different positions.

Cab equipment checked Yes No

## 2. Seat

Check operation of seat controls.

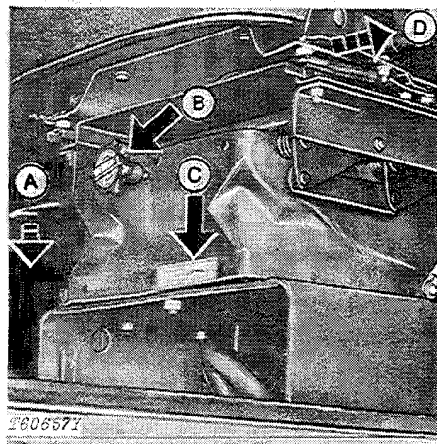

Fig. 3-Controls for Cab Seat and Seat without Cab

A - Height adjustment lever - Push down the lever. Move the seat to the desired position. Release the lever.

B - Weight adjustment knob - Turn the knob clockwise for a firm ride. Turn the knob counterclockwise for a soft ride. Use the flip-out handle to crank the knob.

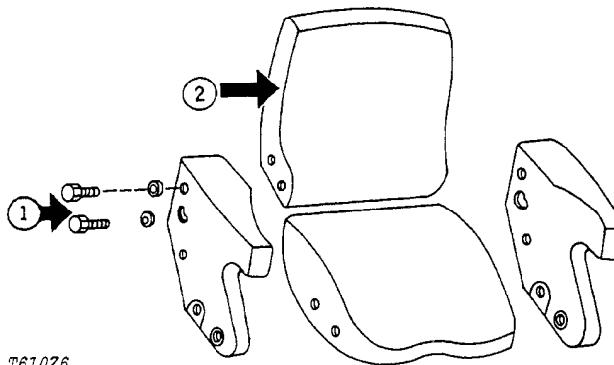

Fig. 5-Adjustment for Seat without Cab

Adjust backrest tilt as follows:

- 1 - Loosen two cap screws on each side.
- 2 - Move the backrest to the desired position.
- 3 - Tighten the cap screws.

Seat controls checked Yes No



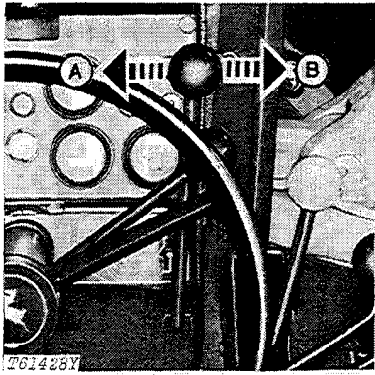

A—Wheel Lean Left (L.H.)      B—Wheel Lean Right (R.H.)

Fig. 10-Wheel Lean Lever

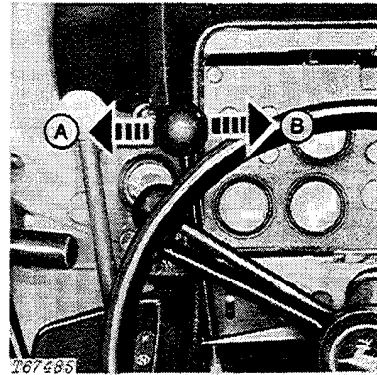

A—Circle Side-Shift Left (L.H.)      B—Circle Side-Shift Right (R.H.)

Fig. 12-Circle Side-Shift Lever

Lean wheels toward turn to make a sharper turn.

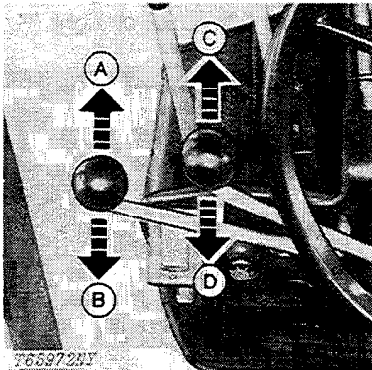

A—Lower Scarifier      C—Pitch Blade Forward  
B—Raise Scarifier      D—Pitch Blade Rearward

Fig. 11-Scarifier Lever and Blade Pitch Lever

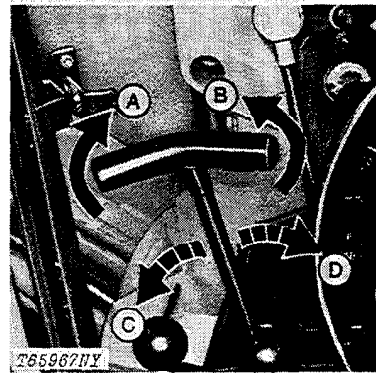

A—Rotate Circle Clockwise      C—Blade Side-Shift Left (L.H.)  
B—Rotate Circle Counterclockwise      D—Blade Side-Shift Right (R.H.)

Fig. 13-Circle Rotation Lever and Blade Side-Shift Lever

Scarifier Lever: Push the lever forward until it locks in float position. Pull the lever back to release it from float.

**IMPORTANT:** Be sure blade does not contact tires or main frame during rotation.

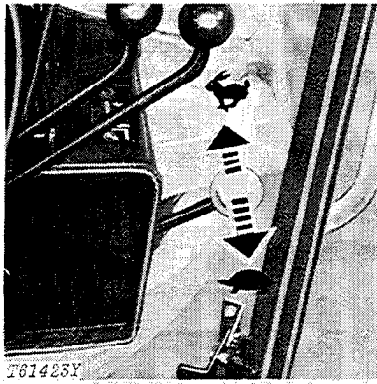

Fig. 14-Hand Throttle

Use the hand throttle to operate at constant speed.

Control levers checked Yes No

### 5. Control Pedals



Fig. 15-Accelerator Pedal

Push down the pedal to increase speed quickly. When you release the pedal, speed will go back to the hand throttle setting.

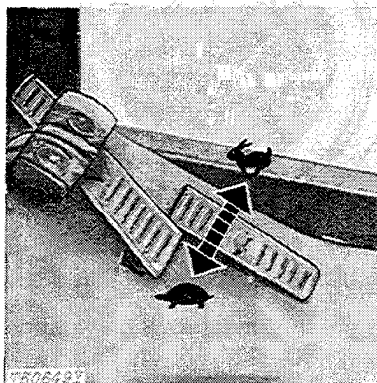
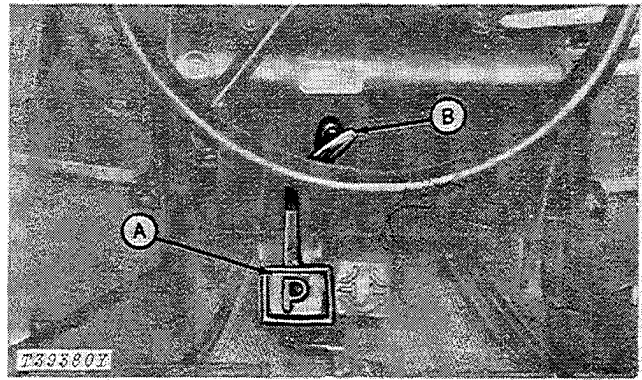

Fig. 16-Decelerator

Push down the pedal to decrease speed quickly. When you release the pedal, speed will go back to the hand throttle setting.



A—Engage Pedal

B—Disengage Handle

Fig. 17-Parking Brake

Push down the parking brake. When the pedal uses over 3/4 total travel to fully engage the brake, change the adjustment. See page I-IV-26.

To release the parking brake, pull handle B, while holding down pedal A to take the load off the latch.

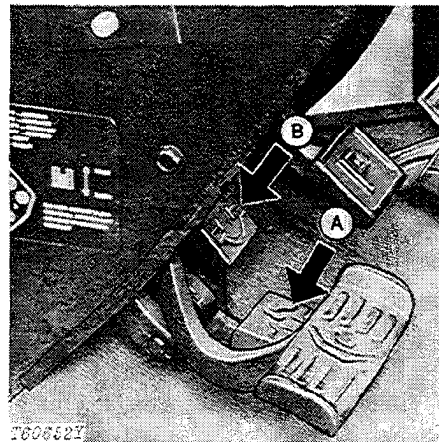

A—Differential Engage Pedal

B—Differential Disengage Pedal

Fig. 18-Differential Lock Pedals

Check the operation of the differential lock. Engage the lock and attempt to turn the steering wheel. If the lock is working correctly, steering resistance must be felt.

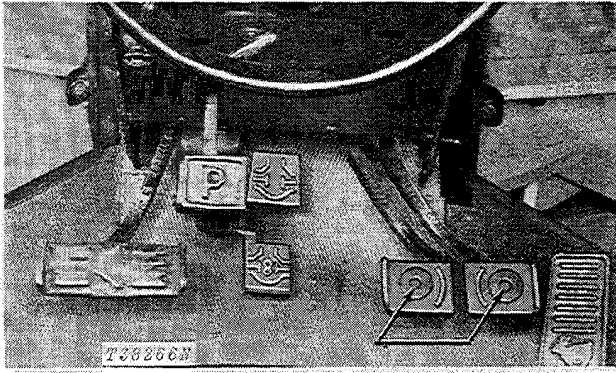
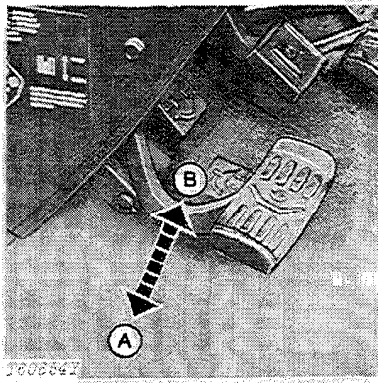

Fig. 19-Brake Pedals

Check the brake system for leaks or wrong operation.

Put the grader in gear. Push down the brake pedal. Moderate pedal force must hold grader in place.

If pedal force does not hold the grader in place, pedal feels spongy or bottoms out, repair is needed, or air must be removed from the system.



A—Disengaged

B—Engaged

Fig. 20-Inching Pedal

Use the inching pedal for precise control of the grader when hitching equipment to the grader or when you need a slow, smooth start.

Push down the pedal (A) to disengage the clutch. Release the pedal (B) to engage the clutch.

**IMPORTANT:** Do not "ride" the inching pedal. Do not use this pedal for normal transmission shifting. Do not push down the pedal for an emergency stop unless the engine is running.

To check the adjustment of the inching pedal, stop the grader. Push down the pedal all the way. When the grader moves ahead strongly, the pedal needs adjustment. See page I-IV-27.

Control pedals checked Yes No

## 6. Gauges

Check the operation of all gauges.

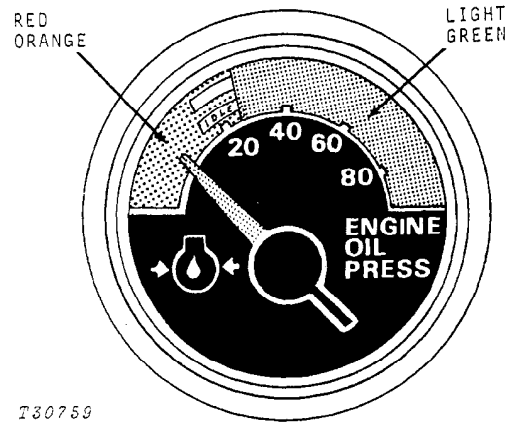

Fig. 21-Engine Oil Pressure Gauge

Normal operating range is shown by the green zone (25-80 psi [1.7-5.5 bar]).

If the indicator hand goes into the red-orange zone, stop the grader. Check the engine oil level. If the oil level is not low, check for restrictions in the oil lines or wrong viscosity oil.

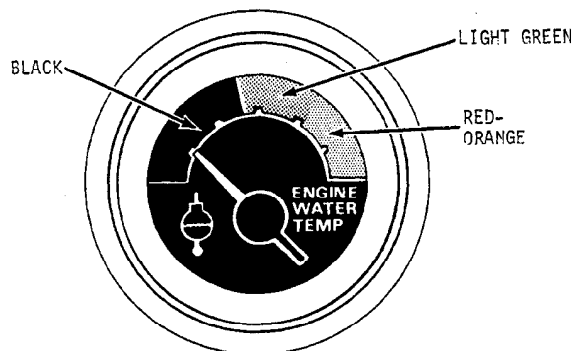
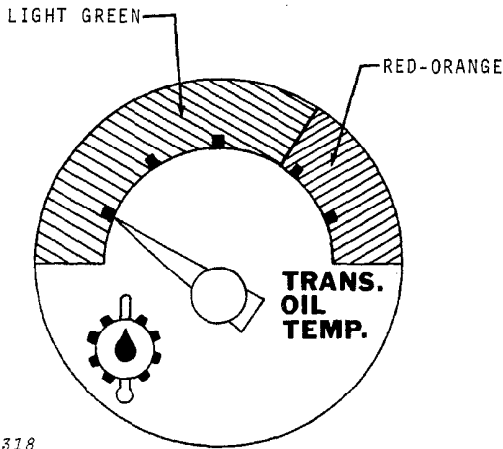

Fig. 22-Engine Coolant Temperature Gauge

The light green zone shows the normal operating temperatures, 160-224°F (71-107°C).

**IMPORTANT:** If the indicator hand goes into the RED-ORANGE ZONE, stop the engine and find the cause.



T39318

Fig. 23-Transmission Oil Temperature Gauge

The light green zone shows the normal operating range, 100-222°F (38-105°C).

If the indicator hand goes into the red-orange zone, operate in a lower gear. If the hand remains in the red zone, check the transmission oil level and the oil cooler for plugging.

If these possible solutions do not lower the oil temperature, do not operate the grader.

**IMPORTANT: Do not operate under load when transmission temperature is in red-orange zone of gauge.**

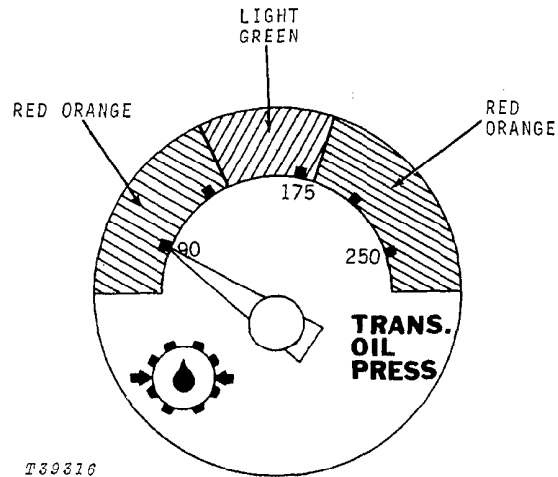

T39316

Fig. 25-Transmission Oil Pressure Gauge

During normal operations, the indicator hand must be in the light green zone. If the indicator hand is in the right (R.H.) red-orange zone, there is too much pressure in the transmission. If the indicator hand is in the left (L.H.) red-orange zone, there is low pressure. If the hand is in either red-orange zone, stop the grader and find the cause.

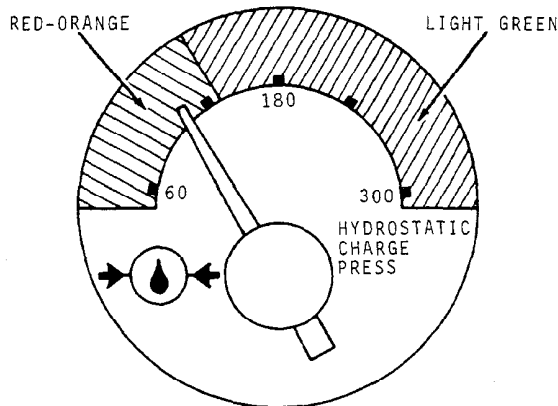

T61271N

Fig. 24-Hydrostatic Charge Pressure Gauge (JD672-A)

Normal operating range is in the light green zone. When the indicator hand goes into the red-orange zone, stop the grader. Find the cause.

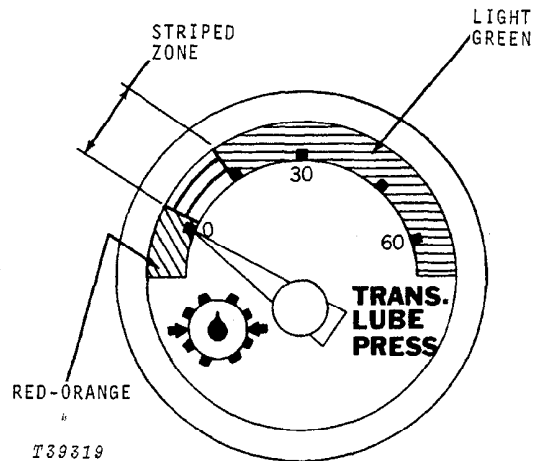

T39319

Fig. 26-Transmission Lube Pressure Gauge

When the engine is idling, throttle pulled completely back, the gauge must show in the striped zone. When operating under constant heavy loads, the gauge must show in the light green zone.

DO NOT operate the grader when the needle is in the red-orange zone. If needle goes into this zone, stop the grader. Check the transmission filter. If the filter is not clogged and the needle is still in the red-orange zone, see your John Deere dealer.

**NOTE:** Transmission lube pressure will vary with engine speed and oil temperature.

Gauges checked Yes No

## 7. Switches

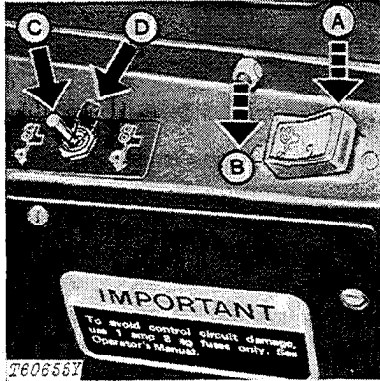

Fig. 27-Hydraulic Front Wheel Drive Switches (JD672-A)

A - Front Wheel Drive ON: Operate in 1st to 4th gear, forward and reverse.

B - Front Wheel Drive OFF.

C - Front Wheel Action NORMAL: Front wheel drive engages only when rear wheels slip. Front wheels turn slightly slower than rear wheels.

D - Front Wheel Action AGGRESSIVE: Front wheels turn slightly faster than rear wheels. For use in difficult conditions, on side slopes, and in wet or slippery spots.

**IMPORTANT:** Switch OFF (B) the hydraulic front wheel drive system before charging batteries or using booster batteries or welding on the grader.

Check the hydraulic front wheel drive on a hard, dry surface, forward and reverse. Turn the hydraulic front wheel drive ON (A). Put the aggressiveness switch in the NORMAL (C) position. Then put the aggressiveness switch to AGGRESSIVE (D). The surge must be noticeable.

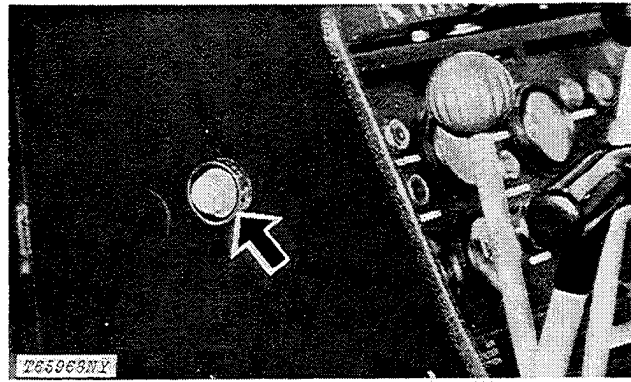
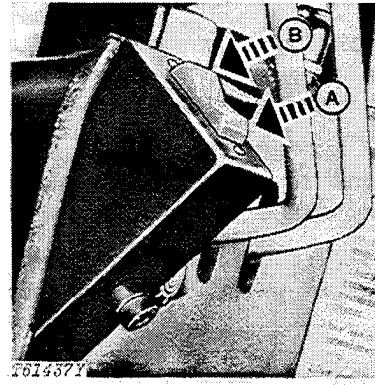

Fig. 28-Starting Aid Button

Remove the starting aid can from the engine. Push the starting aid button. Listen for the solenoid click. Install the starting aid can.



A—Lower Ripper

B—Raise Ripper

Fig. 29-Ripper Switch

Switches checked

Yes No

## 8. Indicator Lights

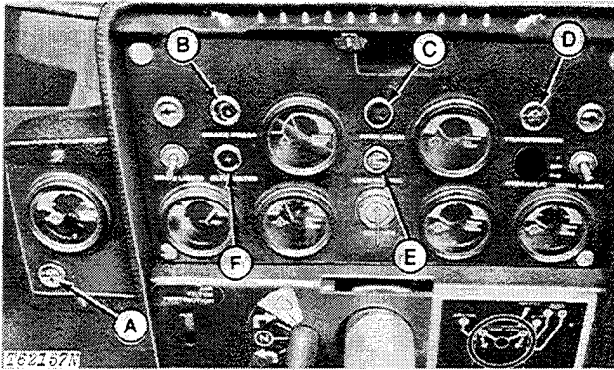

Fig. 30-Indicator Lights

- A - Hydraulic Filter Restriction Indicator Light (JD672-A only): The light is on when the hydraulic front wheel drive pump return filter is plugged. May be on short time when oil is cold.
- B - Brake Pressure Indicator Light: The light is on when brake pressure falls below 1250 psi (88 bar). May be on a short time until pressure builds.
- C - High Beam Indicator Light: The light is on when driving lights are on high beam.
- D - Transmission Filter Restriction Indicator Light: The light is on when the transmission filter is plugged. Will be on until oil is warm.
- E - Locking Pin Indicator Light: The light is on when the locking pin is not fully engaged.
- F - Alternator Indicator Light: The light is on when the alternator is not charging.

Indicator lights checked Yes No

## 9. Lights

Check the operation of all lights, switches, and turn signal lever.

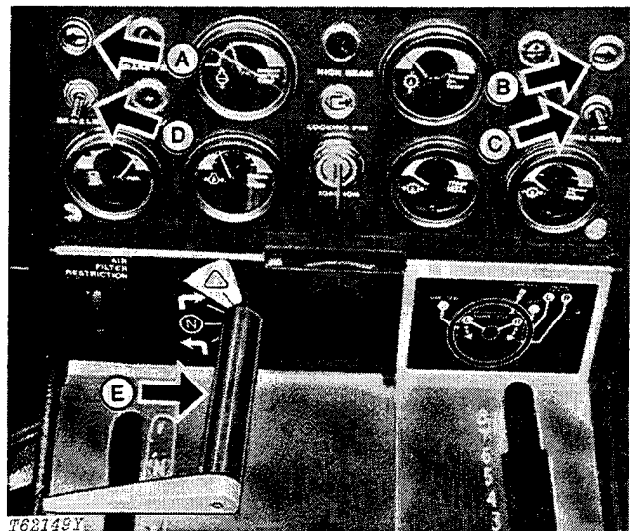

- A—Left (L.H.) Turn Signal Indicator Light
- B—Right (R.H.) Turn Signal Indicator Light
- C—Work Lights Switch
- D—Driving Lights Switch
- E—Turn Signal Lever

Fig. 31-Light Switches and Indicator Lights

Move the turn signal lever to the desired position.

Move the lever to neutral after a turn.

Four amber lights flash as warning lights.

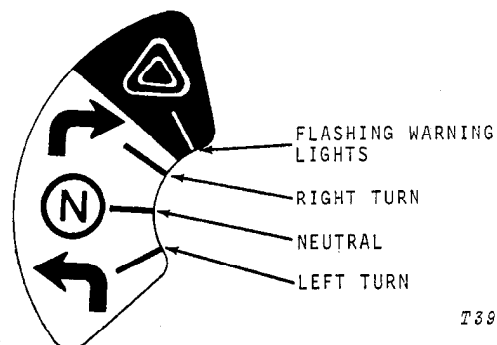

T39382

Fig. 32-Turn Signal Label

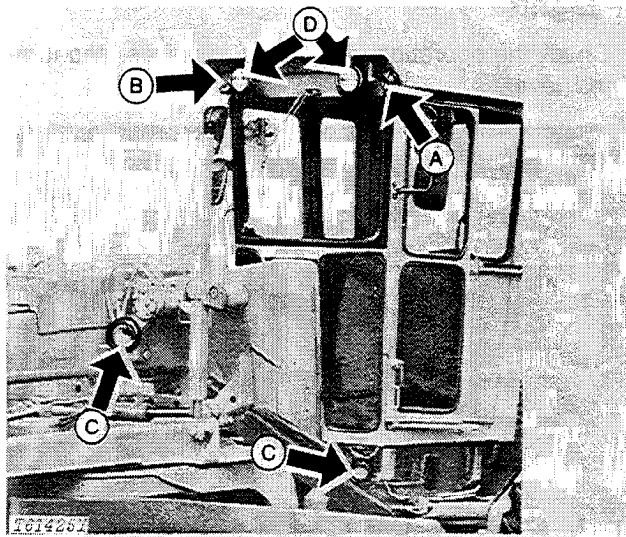

A—Left (L.H.) Turn Signal Light  
 B—Right (R.H.) Turn Signal Light  
 C—Work Lights  
 D—Driving Lights

Fig. 33-Front Lights

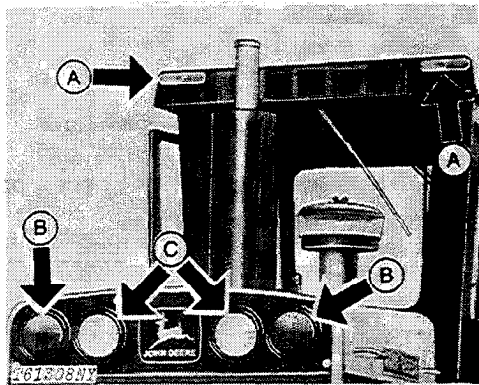

A—Turn Signal Lights  
 B—Brake Lights, Taillights, and Turn Signal Lights  
 C—Working Lights

Fig. 34-Rear Lights

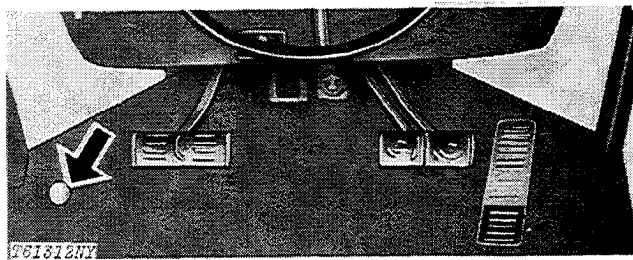

Fig. 35-Dimmer Switch

Lights and switches checked Yes No

## 10. Steering

Start the engine. Operate the steering wheel. Steering must be free and easy when the engine is running.

Steering checked Yes No

## 11. Lift Arm Locking Pin

Check the operation of the lift arm locking pin, locking pin valve plunger, and locking pin indicator light.

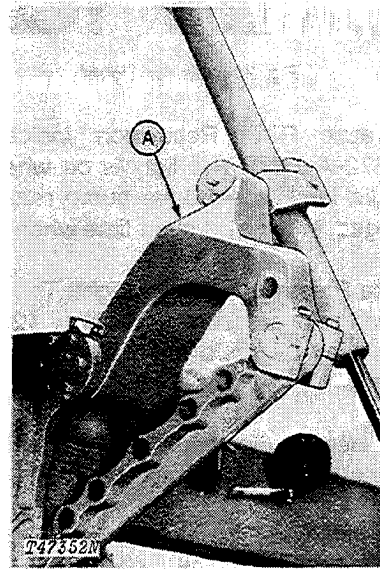

A—Lift Arm

Fig. 36-Lift Arm

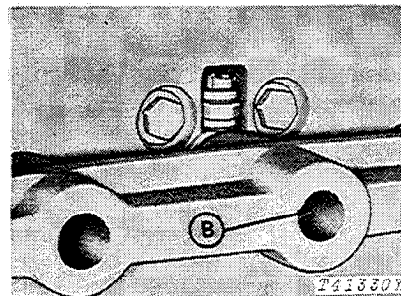

B—Lift Arm Locking Pin

Fig. 37-Lift Arm Locking Pin

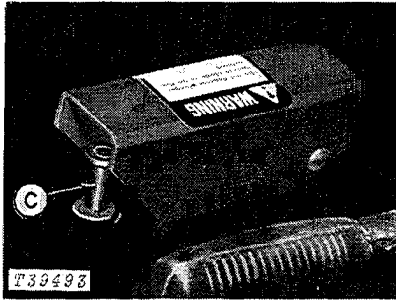

**C—Lift Arm Locking Pin Valve Plunger**

*Fig. 38—Lift Arm Locking Pin Valve Plunger*

When the locking pin valve plunger (C, Fig. 38) is pushed down, the locking pin (B, Fig. 37) retracts from the hole in the crossbar connected to the lift arm (A, Fig. 36). "Rock" the lift arms slightly (using the lift cylinders) to take the load off the locking pin. The indicator light on the instrument panel must be on.

When the locking pin valve plunger is released, the locking pin must go back into the hole in the crossbar connected to the lift arm. The indicator light must go off when the pin is in the hole.

Visually check the pin in the hole when the light is out. Also check if the locking pin valve plunger travels freely.

When the blade lift arm is in the horizontal position (locking pin in the center hole), the pointer on the lift arm must be in line with the center positioning hole in the indicator plate.

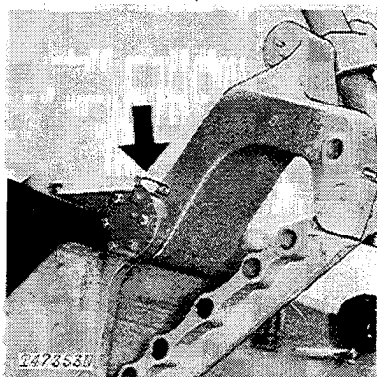

*Fig. 39—Lift Arm Pointer*

If adjustment is needed, loosen the fasteners holding the pointer. Move the pointer to the desired position. Tighten the fasteners.

Indicator plate adjustment required	Yes	No
Locking pin working	Yes	No
Light functioning	Yes	No

Describe any malfunctions:

---



---



---



---



---



---

## 12. Accumulator Action

Check the accumulator reserve capacity as follows:

Start the engine. Run it approximately one minute. Stop the engine. Push down the brake pedals five times at five second intervals. If the brakes do not work after this, the accumulator needs repair.

Accumulator checked Yes No

## 13. Batteries

Check the electrolyte level of the batteries. If distilled water is not available, use clean soft water. Do not use hard water. Remove dirt from the top of the batteries with a damp cloth. Put petroleum jelly on terminals.

**IMPORTANT: Never add water to the batteries in freezing weather unless the engine will be run 2 or 3 hours.**

Check battery connections.

Punch date code on batteries.

Batteries checked Yes No

## 14. Air Intake System

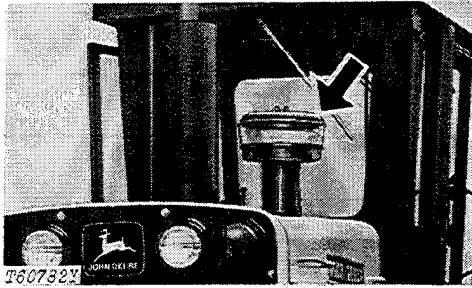

Fig. 40-Pre-Cleaner

Check and clean the pre-cleaner bowl.

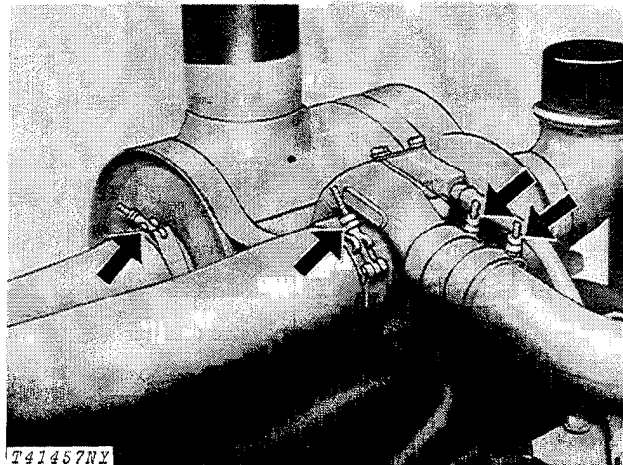

Fig. 42-Air Intake Hose Clamps

Check clamps on hoses from the air cleaner to the turbocharger tube and from the air intake manifold to the turbocharger tube. Tighten hose clamps if necessary. Inspect hoses for cracks.

Air intake system checked

Yes No

## 15. Radiator

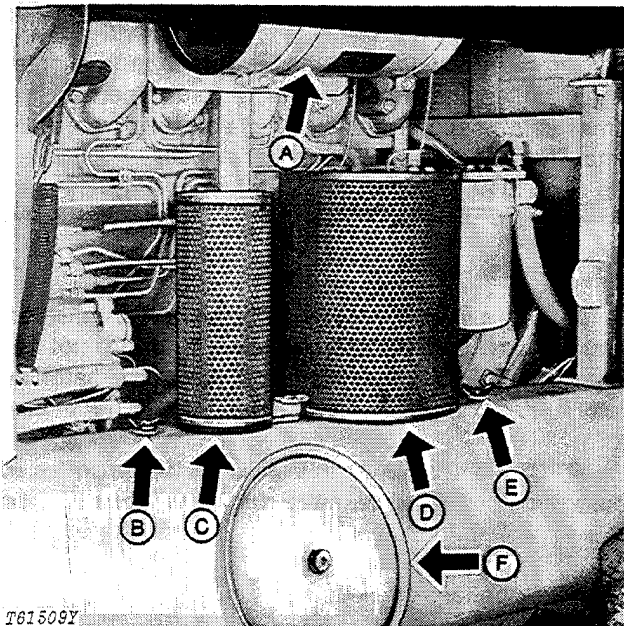

T61509Y

- |                               |                      |
|-------------------------------|----------------------|
| A—Air Cleaner Housing         | D—Primary Element    |
| B—Wing Nut for Safety Element | E—Wing Nut for Cover |
| C—Safety Element              | F—Air Cleaner Cover  |

Fig. 41-Air Cleaner

Check the air cleaner restriction indicator on the instrument panel. If the indicator shows red, check and clean both primary and safety elements. Install new elements, if necessary.

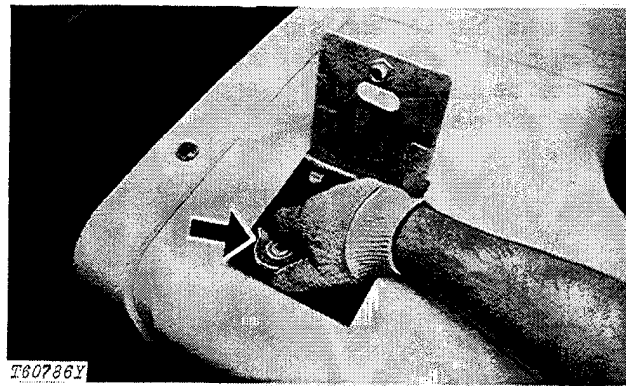

T60786Y

Fig. 43-Removing Radiator Cap

**CAUTION:** Do not remove the radiator filler cap unless you can hold your hand on the radiator tank. First, loosen the cap slowly to the stop. Then release all pressure in the cooling system before removing the cap.

Check the level of the coolant in the radiator. Coolant must be 4 in. (102 mm) below the top of the filler neck. Use clean water for warm weather. Use a solution of 50% clean water and 50% permanent antifreeze (ethylene glycol with approved rust inhibitor) for cold weather.



**Suggest:**

**If the above button click is invalid.**

**Please download this document**

**first, and then click the above link**

**to download the complete manual.**

**Thank you so much for reading**

Check the cooling system for loose connections and leaks. Remove trash from the radiator.

Coolant level checked Yes No

### 16. Transmission-Hydraulic System Oil Level

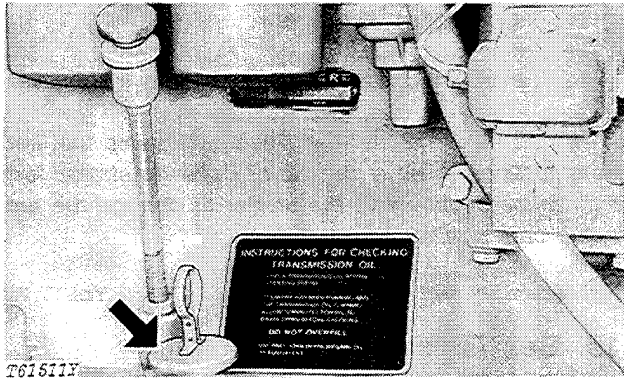

Fig. 44-Transmission-Hydraulic System Filler Cap and Dipstick

To check the transmission-hydraulic system oil level, fully insert the dipstick in the dipstick tube.

Before starting the engine, check the oil level. If the oil level is at or near the upper mark, there is enough oil in the system to permit starting the engine. If oil level is low, add oil specified on page I-V-2. Install the dipstick.

**NOTE:** Do not add oil above the top mark on the dipstick.

Transmission-hydraulic oil level checked Yes No  
 Transmission-hydraulic oil added \_\_\_\_\_ qts. (L)

### 17. Crankcase Oil Level

Check crankcase oil level when the machine is on level ground and the engine is off. If oil level is at or below the bottom mark on the dipstick, add oil specified on page I-V-2 to bring oil level to between marks on dipstick. Do not operate the engine when the oil level is below the bottom mark.

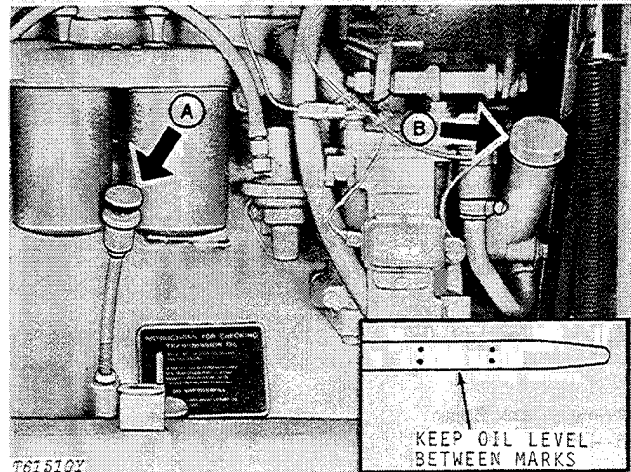

A—Dipstick

B—Filler Cap

Fig. 45-Crankcase Oil Level

**NOTE:** There is 2 quarts (1.9 L) difference between the bottom mark and the top mark on the dipstick.

Crankcase oil level checked Yes No  
 Oil added \_\_\_\_\_ qts. (L)

### 18. Fuel System

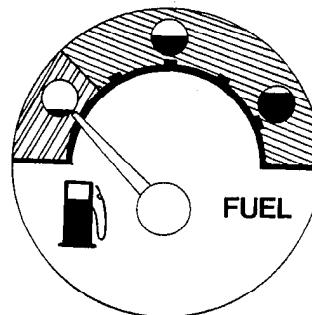

T40227N

Fig. 46-Fuel Level Gauge

Fill the fuel tank with correct fuel.

Check the operation of the fuel gauge.

The fuel gauge shows the amount of fuel in the fuel tank.

**<https://www.ebooklibonline.com>**

Hello dear friend!

Thank you very much for reading.

Enter the link into your browser.

The full manual is available for immediate download.

**<https://www.ebooklibonline.com>**