

# 650 and 750 Tractors



JOHN DEERE

## OPERATORS MANUAL

650 and 750  
Tractors

OMRW15455 L4 English

John Deere  
Lawn & Grounds Care Division  
OMRW15455 L4

LITHO IN U.S.A.  
ENGLISH



## WARRANTY

Warranty is provided as part of John Deere's support program for customers who operate and maintain their equipment as described in this manual.

The warranty does not cover:

**A**—Products which have been altered or modified in ways not approved by John Deere, including setting fuel delivery above specifications or otherwise overpowering of products.

**B**—Depreciation or damage caused by normal wear, accident, lack of reasonable and necessary maintenance as specified in this manual, improper maintenance, improper protection in storage, or improper use or abuse.

**C**—Normal maintenance and replacement of service items such as filters, spark plugs, belts, brake linings, cutting blades and hoses unless such items are defective.

**D**—Transportation, mailing and service call charges for warranty service.

## SAFETY



This safety alert symbol indicates important safety messages in this manual. When you see this symbol, be alert to the possibility of personal injury and carefully read the message that follows.

## DIRECTIONS

"Right-hand" and "left-hand" sides of the tractor are determined by facing in the direction of tractor forward travel.

## SYMBOLS

Worldwide symbols are used to assist identification and operation. In this manual, an identifying symbol is placed by the instructions like the example at the left for the symbol on the engine oil pressure gauge. The cylinder block in the symbol represents the engine, the drop signifies the oil, and the arrows indicate pressure. Regardless of the language used in a nation, the symbol means engine oil pressure without translation.

## MEASUREMENTS

This tractor is of metric design.

For your convenience, most specifications are given in metric measurement with the customary U.S. measurement following.

Some specifications cannot be converted. These appear in metric only.

Most hardware is metric. Specified metric hardware must be used for replacement.



**CAUTION: Use only metric tools. Other tools may not fit properly. They may slip and cause injury.**

## PRODUCT IDENTIFICATION NUMBERS

Record the identification number(s) in the space provided following Specifications. Accurately record all of the characters because (should the product be stolen) tracing is sometimes through a computer match of letters and numbers. Also, your dealer needs this information when ordering parts. If you carry your operator's manual on the machine for reference, be sure to also record the identification number(s) on a separate sheet of paper and file it in a secure place not on the machine so you will still have a record in case the machine is stolen.

# Contents

Identification View .....	2
Safety .....	3
Controls and Instruments .....	8
Operator's Station .....	11
Engine Break-in .....	12
Prestarting Checks .....	13
Operating the Engine .....	15
Operating the Tractor .....	23
Rockshaft and 3-Point Hitch .....	28
Remote Hydraulic Cylinders (Optional) .....	37
Drawbar and PTO .....	42
Ballast .....	46
Wheels, Tires, and Treads .....	54
Transporting .....	57
Lighting and Signals .....	60
Fuels and Lubricants .....	62
Lubrication and Maintenance .....	66
Service .....	83
Storage .....	105
Trouble Shooting .....	108
Crime Prevention Tips .....	112A
Specifications .....	113
Identification Numbers .....	115
Index .....	116
Daily Maintenance .....	120
Lubrication and Maintenance Record .....	120

**<https://www.ebooklibonline.com>**

Hello dear friend!

Thank you very much for reading.

Enter the link into your browser.

The full manual is available for immediate download.

**<https://www.ebooklibonline.com>**

# Identification View



*John Deere 650 Tractor*

A09;RW1071 4 U01;ID 650 061284

U05;P2 071284

# Safety

## KEEP RIDERS OFF MACHINE

Only allow the operator on the machine. Keep riders off.

Riders on a machine are subject to injury such as being struck by foreign objects and being thrown off of the machine. Riders also obstruct the operator's view resulting in the machine being operated in an unsafe manner.



AB6;TS173 053;RIDER 261184

## OPERATE TRACTOR SAFELY

Slow down for hillsides, rough ground, and sharp turns. Couple the brake pedals together before driving at transport speeds.

When implements or attachments are used with tractor, always follow safety precautions listed in implement operator's manual or operating instructions. When raising a heavy object with a loader, be sure the object is secure from falling. It could fall on and seriously injure a bystander or the operator.

U01;SA01 201284

## AVOID TIP-OVERS

Avoid holes, ditches, etc. which may cause the tractor to tip, especially on hillsides.

Tractors with narrow tread width require extra driving caution to prevent tip-overs. Slow down before sharp turns, especially on rough ground and slopes. You can improve stability by adjusting rear wheels to maximum tread width, see page 55.

Front-wheel drive (A) greatly increases traction. When this option is used, extra caution is needed on slopes. Compared to 2-wheel drive, a front-wheel drive tractor maintains traction on steeper slopes, increasing the possibility of a tip over.

Never drive near the edge of a gully or steep embankment—it might cave in.

Driving forward out of a ditch or mired condition or up a steep slope could cause tractor to tip over rearward. Back out of these situations if possible.

Hitch towed loads only to the drawbar. When using a chain, take up the slack slowly.

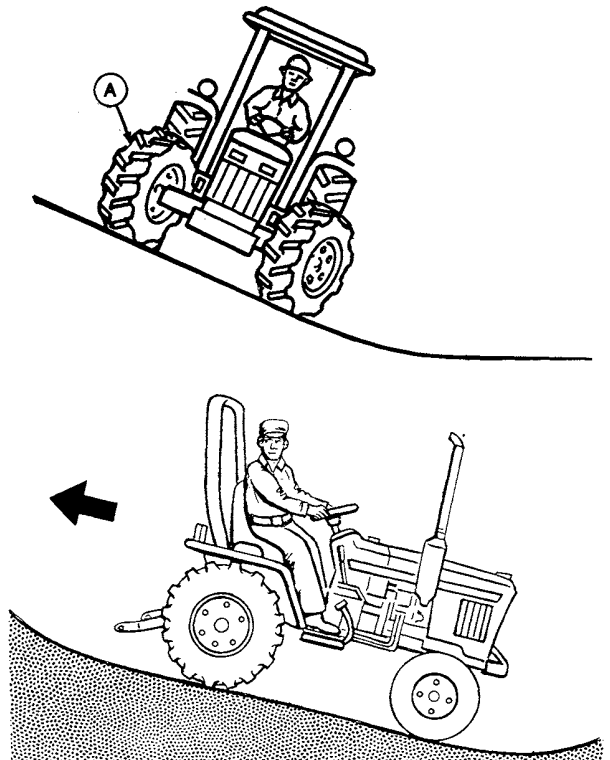

A09;RW8023L,RW207 U01;SA02 010982

U05;P3 201284

### USE SEAT BELT PROPERLY

Use a seat belt when you operate with a roll-over protective structure (ROPS) to minimize chance of injury from an accident such as an overturn.

Do not use a seat belt if operating without a ROPS.

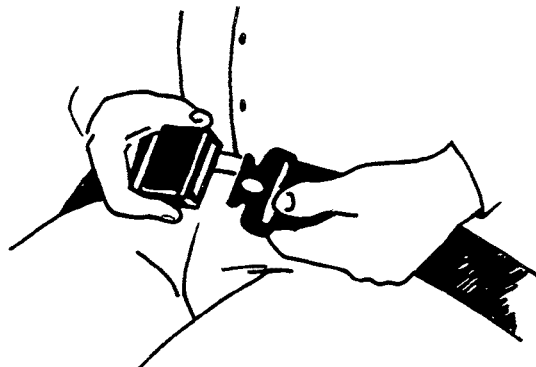

AB6;TS175 053;ROPS1 261184

### KEEP ROPS INSTALLED PROPERLY

Make certain all parts are reinstalled correctly if the roll-over protective structure (ROPS) is loosened or removed for any reason. Tighten mounting bolts to proper torque.

The protection offered by ROPS will be impaired if ROPS is subjected to structural damage, is involved in an overturn incident, or is in any way altered. A damaged ROPS should be replaced, not reused.

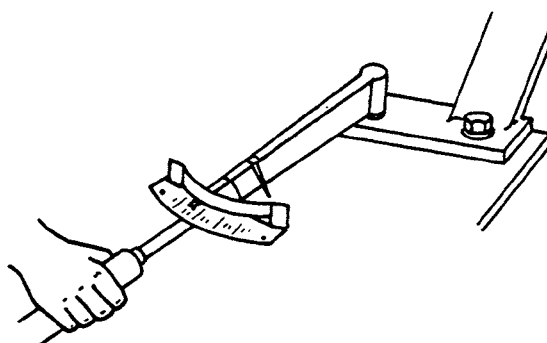

AB6;TS176 053;ROPS3 261184

### TRANSPORT TRACTOR SAFELY

Before descending a steep hill, shift to a low gear to control the tractor with little or no braking. Make sure brake pedals are locked together. Never coast downhill.

When transporting on icy or graveled surfaces, be alert for skids which could result in loss of steering control. To decrease chance of skids, reduce speed and be sure tractor is properly ballasted.

Never tow tractor faster than 32 km/h (20 mph). (See Selecting Towing Speeds in Transporting section.)

U01;TRANS PORT 061284

U05;P4 201284

### STAY CLEAR OF PTO

Stop the engine and be sure both the rear PTO and the front PTO (if equipped) drive line have stopped before:

- Connecting or disconnecting a PTO drive line
- Making any adjustment to PTO drive line or hitch
- Cleaning out PTO driven equipment.

PTO master shield and other drive line shields should be in place at all times except for special applications as directed in the operator's manual.

The PTO guard should be in place when the PTO is not being used.

Operate PTO at recommended speeds.

The optional front PTO and attachment should stop completely in seven seconds or less. See page 99 for adjustment instructions.

Avoid loose-fitting or dangling clothing.

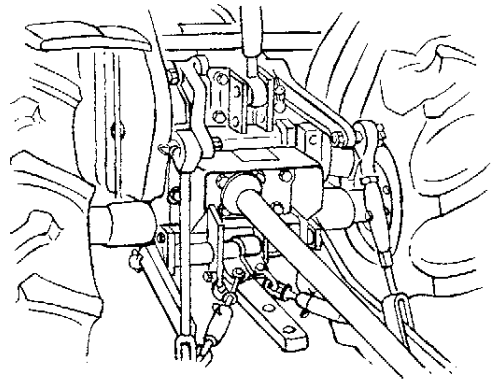

A09KX210 U01,P10 06:284

### STAY CLEAR OF MOVING TRACTOR

Never attempt to start or operate tractor except from operator's station.

Be sure everyone is clear of tractor and attached equipment before starting engine. Some movement may occur as engine starts.

Never try to get on or off a moving tractor.

Before dismounting, lock the brakes and lower implements to the ground. If tractor is to be left unattended, stop the engine and remove the key.

U01:STAY CLEAR 201284

U05:P5 071284

### AVOID HIGH-PRESSURE FLUIDS

Escaping fluid under pressure can penetrate the skin causing serious injury. Relieve pressure before disconnecting hydraulic or other lines. Tighten all connections before applying pressure. Keep hands and body away from pinholes and nozzles which eject fluids under high pressure. Use a piece of cardboard or paper to search for leaks.

If ANY fluid is injected into the skin, it must be surgically removed within a few hours by a doctor familiar with this type injury or gangrene may result.



AB6;X9811 053;FLUID 100584

### AVOID EXPLOSIONS OR FIRE

Before using booster batteries, read the instructions on page 19. Before connecting or disconnecting a battery charger, turn the charger off to avoid sparks.

Be careful with any type of fuel. Do not refuel the tractor when the engine is hot or running. Never smoke while handling fuel.

A fire extinguisher can be mounted to your tractor. It is available from your John Deere dealer. Be sure to see the owners manual packaged with the extinguisher for operation and service instructions.



A09;RW5895;RW2389 301;SA10 010982

### PREVENT MACHINE RUNAWAY

Avoid possible injury or death from machinery runaway.

Do not start engine by shorting across starter terminals. Machine will start in gear and will move if normal circuitry is by passed.

NEVER start engine while standing on ground. Start engine only from operator's seat, with transmission in neutral or park.



AB6;TS177 053;BYPAS1 110584

### TOW EQUIPMENT PROPERLY

Use caution when towing loads at transport speeds. Reduce speed if towed load weighs more than the tractor and is not equipped with brakes. Avoid hard braking applications. (Consult implement operator's manual for recommended transport speeds.)

Use additional caution when transporting towed loads under adverse surface conditions, when turning, or on inclines.

U01;TOW 061284

### USE A SAFETY CHAIN

A safety chain will help control drawn equipment (B) should it accidentally separate from the drawbar (A) while transporting. Using the appropriate adapter parts, attach the chain to the tractor drawbar support or other specified anchor location. Provide only enough slack in the chain to permit turning. See your John Deere dealer for a chain with a strength rating equal to or greater than the gross weight of the towed machine.

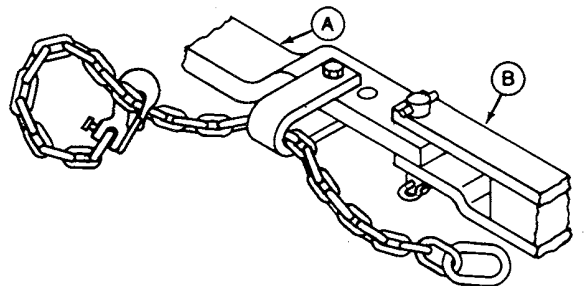

AB6;TS163 053;CHAIN 310884

### MAKE TRACTOR VISIBLE ON HIGHWAY

Turn light switch to "bright head lamp" position. Never use white lights which are visible from the rear. Always dim head lamps before meeting another vehicle. Keep head lamps properly adjusted.

Add SMV emblem, reflectors, and auxiliary lighting to equipment as required for safety and by local regulations.

Before operating tractor on highway, be sure flashing warning lamps work properly.

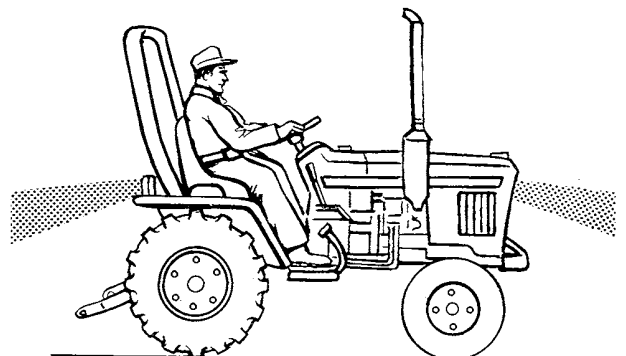

A09;RW209 U01;HIWAY 061284

U05;P6A 071284

### AVOID EXHAUST FUMES

Never run engine in a closed building.

The exhaust system may be adjusted to a horizontal position if the vertical position is in the way. See page 102.

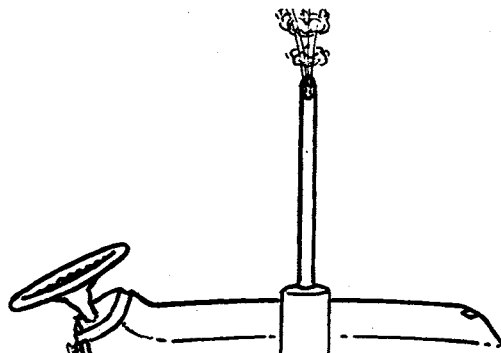

A09;RW8024L U01;SA06 031182

### PROTECT AGAINST NOISE

Prolonged exposure to loud noise can cause impairment or loss of hearing.

Wear a suitable hearing protective device such as earmuffs (A) or earplugs (B) to protect against objectionable uncomfortable loud noises.



AB6;X7662 053;NOISE 150584

### DO NOT MODIFY TRACTOR

Unauthorized modification to the machine may impair the function and/or safety and affect machine life.

Never modify structural members of ROLL-GARD protective frame (A) by welding, bending, drilling or cutting as this might weaken the structure. If any structural member is damaged, replace the entire structure. Do not attempt repairs.

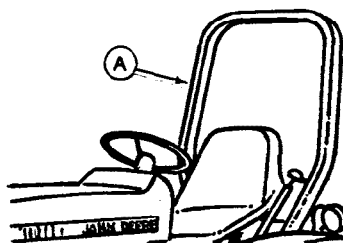

A09;RW8025L U01;MODIFY 650 061284

### SERVICE TRACTOR SAFELY

Do not service the tractor while it is in motion or while the engine is running.

Disconnect the battery ground cable before working on the electrical system or working in any area where you might accidentally contact electrical components.

Reinstall all shields or protective equipment removed during service.

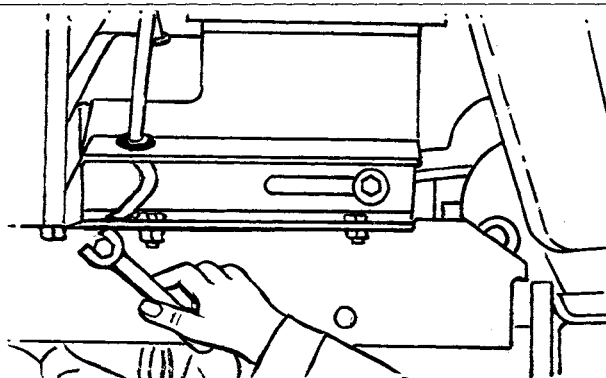

A09;RW211 U01;WRENCH 061284

### SERVICE COOLING SYSTEM SAFELY

Under normal circumstances, radiator cap should not be removed. Add coolant to cooling system through coolant recovery tank (A).

Do not remove radiator cap when engine is hot. Shut the engine off and wait until it cools. When removing cap turn to the first stop to relieve pressure before removing it completely.

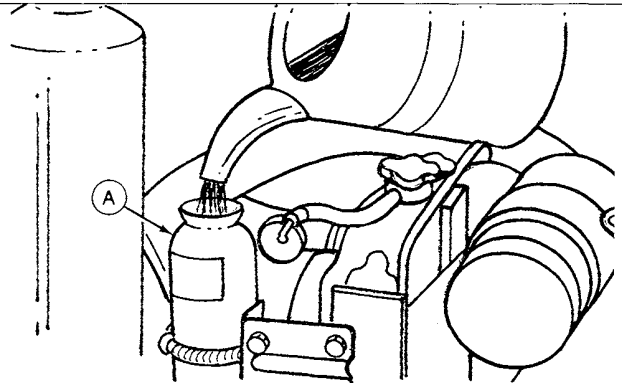

A09;RW305 U01;SA11 201282

### SERVICE TIRES SAFELY

Failure to follow proper procedures when mounting a tire on a wheel or rim can produce an explosion which may result in serious injury or death. Do not attempt to mount a tire unless you have the proper equipment and experience to perform the job. Have it done by your John Deere dealer or a qualified tire repair service.

When sealing tire beads on rims, never exceed 35 psi (241 kPa) (2.4 bar) or maximum inflation pressures specified by tire manufacturers for mounting tires. Inflation beyond this maximum pressure may break the bead, or even the rim, with dangerous explosive force. If both beads are not seated when the maximum recommended pressure is reached, deflate, reposition tire, relubricate bead and reinflate.

Detailed tire mounting instructions, including necessary safety precautions, are contained in John Deere Fundamentals of Service (FOS) Manual 55, Tires and Tracks, available through your John Deere dealer. Such information is also available from the Rubber Manufacturers Association and from tire manufacturers.

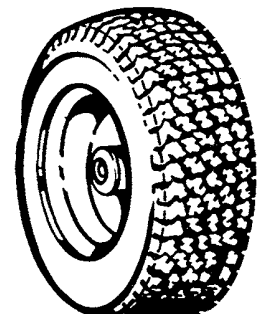
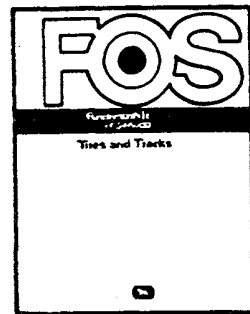
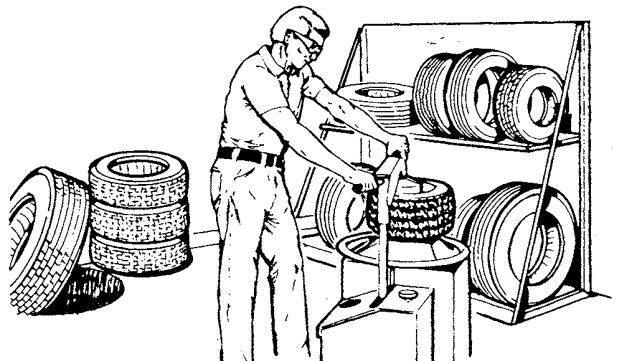

AB6;M34163, M34164 053;TIRE4 091283

### HANDLE CHEMICALS PROPERLY

Follow instructions given in the implement operator's manual and those given by the chemical manufacturer when using agricultural chemicals.

U01;HANDLE 1 061284

U05;P7 071284

# Controls and Instruments

## LOCATING TRACTOR CONTROLS

	Page
A—Steering Wheel .....	8
B—Turn Signal .....	61
C—Light Switch .....	60
D—Front PTO Switch (optional) .....	45
E—Hand Throttle .....	21
F—Key Switch .....	16
G—Brake Pedals .....	23
H—Parking Brake Lever .....	23
I—Foot Throttle .....	21
J—Gear Shift Lever .....	24
K—Range Shift Lever .....	24
L—Rockshaft Control Lever .....	31
M—Differential Lock Pedal .....	26
N—Hydraulic Stop Valve .....	30, 32
O—Speed-of-Drop Valve .....	31
P—PTO Control Lever .....	44
Q—Front-Wheel Drive Shift Lever (optional) .....	27
R—Clutch Pedal .....	25

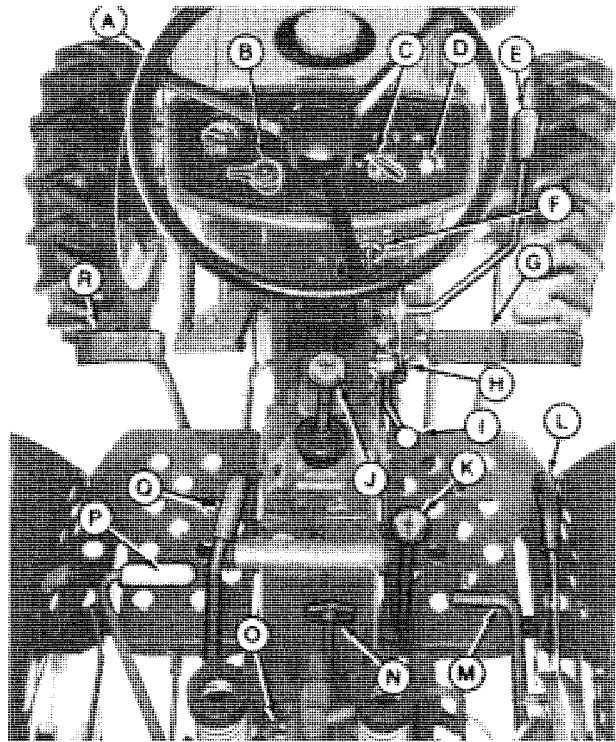

A09;RW8026 U01;C101A 061284

## GAUGES AND INSTRUMENTS

	Page
A—Tach Hourmeter .....	9
B—Fuel Gauge .....	9
C—Charging System Indicator .....	10
D—Coolant Temperature Indicator .....	10
E—Oil Pressure Indicator .....	10

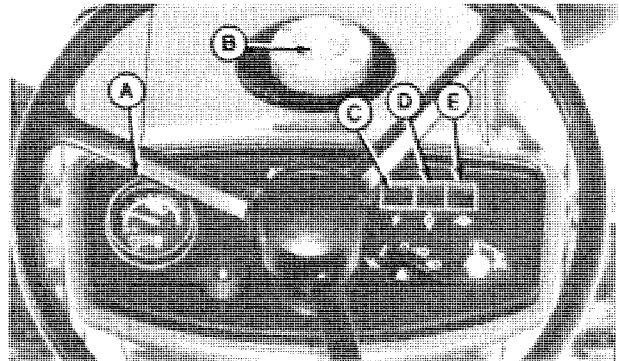

A09;RW8027 U01;C101B 031182

### CHECK INSTRUMENTS OFTEN

Leave key switch on while operating tractor so instruments will function. Check indicator lamps each time engine is started to be sure they work.

U01;CI02 010982

### WORKING WITH THE TACH HOURMETER

Tach hourmeter shows engine speed in rpm (A), and hours of operation in full hours and tenths (B).

Rear PTO speed is monitored with the tach hourmeter. Align needle with "PTO Rated" mark (C) for standard rear PTO speed (540 rpm). PTO rated engine speed is 2350 rpm for the 650 Tractor or 2300 rpm for the 750 Tractor.

"PTO Max" mark (D) indicates a ten percent overspeed of PTO and is maximum engine speed for use in PTO operations.

**IMPORTANT: Never exceed indicated PTO max speed when PTO is engaged.**

- A—Engine Speed
- B—Hour Meter
- C—PTO Rated Mark
- D—PTO Max Mark

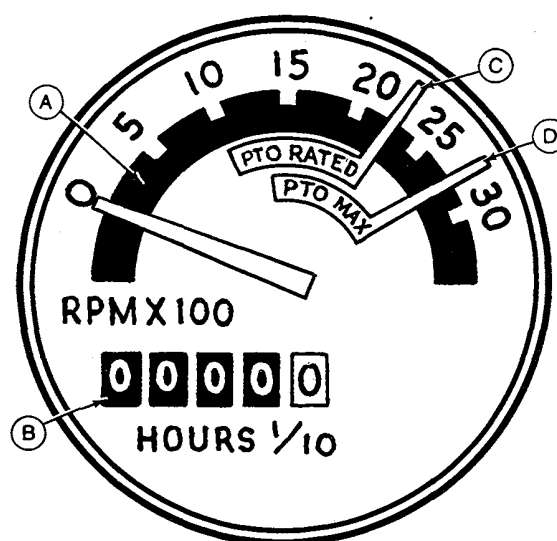

A09;RW215 U01;CI03 010982

### WATCH FUEL LEVEL

**IMPORTANT: Use diesel fuel only. See fuel specifications on page 62.**

Stop to refuel before gauge (A) reaches empty mark. Should tractor run out of fuel, and not start in several attempts, air must be bled from fuel lines. (See Bleeding Fuel Lines in Service section).

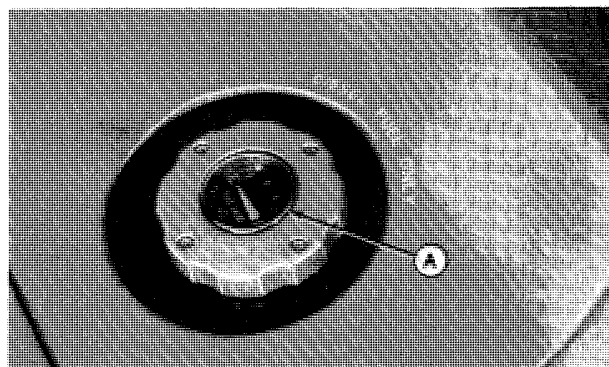

A09;RW216 U01;CI04 031182

### WATCH INSTRUMENT INDICATOR LAMPS

**IMPORTANT:** All three indicator lamps (A) should glow when the key is turned to engage starter. If a lamp glows for more than five seconds at any other time during normal operation, stop the engine and determine the cause.

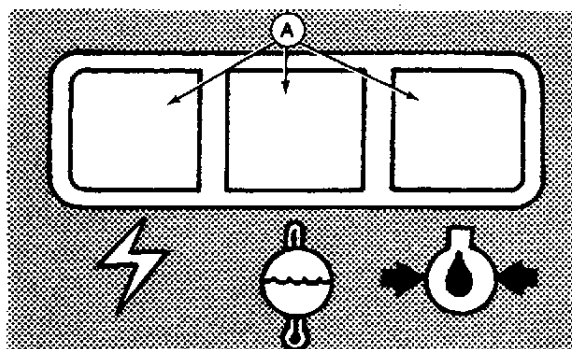

A09/RW217 U01;C105 010982

### CHECK CHARGING SYSTEM INDICATOR

Charging system lamp (A) will glow when alternator output is too low. If loose fan belt (page 86) is not the cause, see your John Deere dealer.

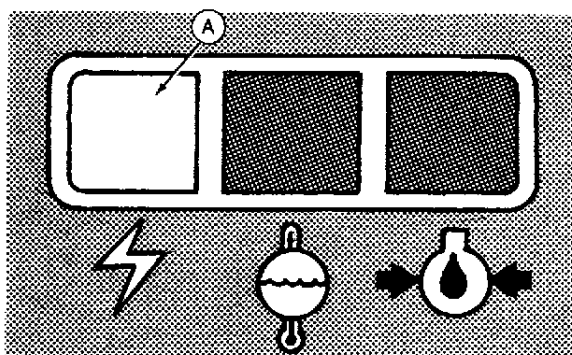

A09/RW218 U01;C106 030982

### CHECK COOLANT TEMPERATURE INDICATOR

Temperature lamp (A) will glow if engine coolant temperature becomes too high. If lamp glows, check coolant level in coolant recovery tank. Also check grille, side screens and radiator for plugging. Check fan belt tension, see page 86.

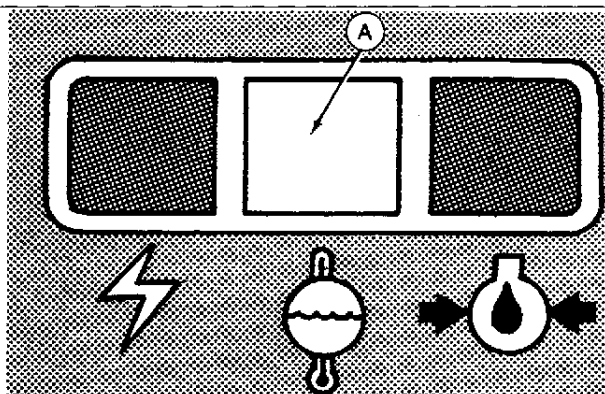

A09/RW219 U01;C107 010982

### CHECK OIL PRESSURE INDICATOR

Oil pressure lamp (A) glows if engine oil pressure falls too low. If low oil level (page 68) is not the cause, see your John Deere dealer.

**IMPORTANT:** Never operate an engine without sufficient oil pressure.

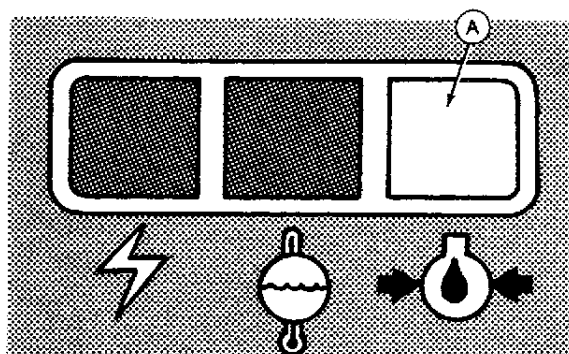

A09/RW220 U01;C108 030982



**Suggest:**

**If the above button click is invalid.**

**Please download this document**

**first, and then click the above link**

**to download the complete manual.**

**Thank you so much for reading**

# Operator's Station

## ADJUST SEAT

To move seat forward or back, remove clip (A), and pin (B) and reinstall through desired adjustment holes (C).

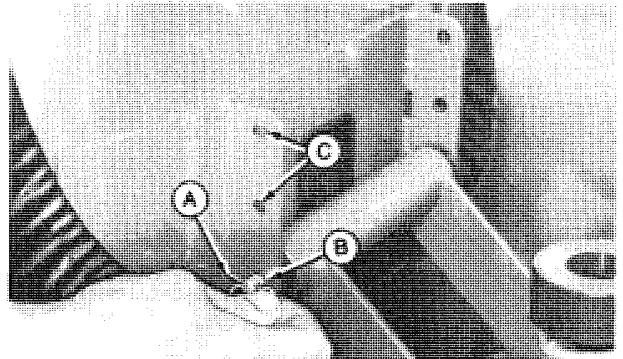

To protect seat when tractor is not in use, tilt it forward.

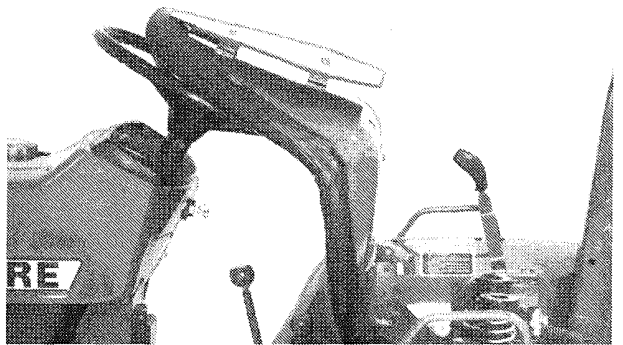

A09;RW6026,RW6029 U01;0501 010982

## USE SEAT BELT



**CAUTION:** Use a seat belt when you operate with a roll-over protective structure (ROPS) to minimize chance of injury from an accident such as an overturn.

**Do not use a seat belt if operating without a ROPS.**

Use of a seat belt is not recommended for tractors without a rollover protective device.

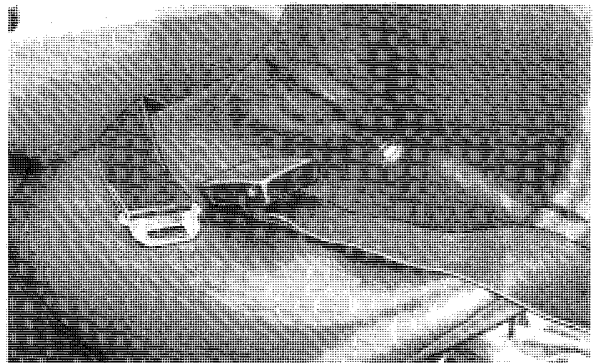

A09;RW223 U01;0502 201284

**<https://www.ebooklibonline.com>**

Hello dear friend!

Thank you very much for reading.

Enter the link into your browser.

The full manual is available for immediate download.

**<https://www.ebooklibonline.com>**