

John Deere 550B Crawler Dozer and 555B Crawler Loader

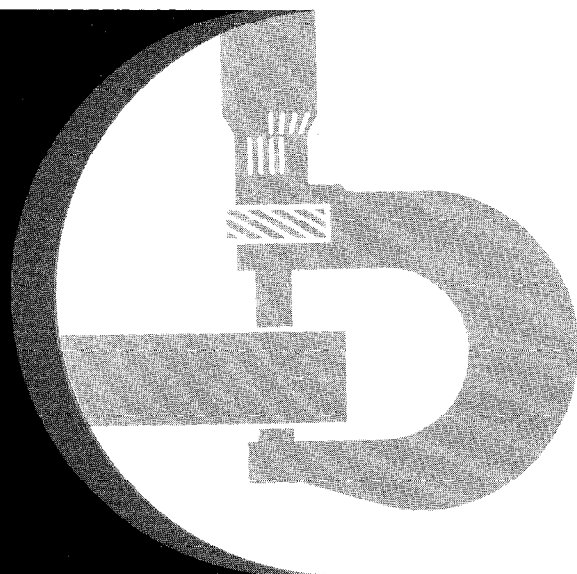

TECHNICAL MANUAL

TM-1331 (Aug-87)

LITHO IN U.S.A.

550B CRAWLER DOZER AND 555B CRAWLER LOADER TECHNICAL MANUAL TM-1331 (AUG-87)

SECTION AND GROUP CONTENTS

SECTION I - GENERAL INFORMATION

- Group I - Introduction and Safety Information
- Group II - General Specifications
- Group III - Torque Specifications Chart
for Cap Screws and Hydraulic
Fittings
- Group IV - Lubrication

SECTION 01 - TRACKS

- Group 0130 - Track Systems
Track Chain, Track frame, Track Carrier
Roller, Front Idler, Track Roller and Track
Adjuster

SECTION 02 - AXLES AND SUSPEN- SION SYSTEMS

- Group 0250 - Axle Shaft, Bearings, and Re-
duction Gears
Final Drive, Steering Clutch, Brake Band,
Steering Clutch Housing and Linkage

SECTION 03 - TRANSMISSION

- Group 0315 - Controls
- Group 0350 - Gears, Shafts, Bearings, Power
Shift Clutch, and Torque Converter
- Group 0360 - Hydraulic System
Oil Pump, Transmission Control Valve,
Selector Valve, Oil Filter

SECTION 04 - ENGINE

- Group 0400 - Removal and Installation
- Group 0401 - Crankshaft and Main Bearings
- Group 0402 - Camshaft and Valve Actuating
Means
- Group 0403 - Connecting Rods and Pistons
- Group 0404 - Cylinder Block (Liners)
- Group 0407 - Engine Oiling System
- Group 0409 - Cylinder Head and Valves
- Group 0410 - Exhaust Manifold
- Group 0413 - Fuel Injection System
- Group 0415 - Engine Balancer
- Group 0416 - Turbocharger
- Group 0417 - Water Pump
- Group 0418 - Thermostats, Housing and Piping
- Group 0419 - Engine Oil Cooler
- Group 0420 - Fuel Filter
- Group 0421 - Fuel Transfer Pump
- Group 0422 - Starting System
- Group 0433 - Flywheel, Housing and Fasteners

SECTION 05 - ENGINE AUXILIARY SYSTEMS

- Group 0505 - Cold Weather Starting Aids
- Group 0510 - Cooling Systems
- Group 0515 - Speed Controls
- Group 0560 - External Fuel Supply Systems

SECTION 06 - TORQUE CONVERTER

- Group 0651 - Converter, Turbine, Gears, and
Shafts (See Group 0350)

Continued on next page

All information, illustrations and specifications contained in this technical manual are based on the latest information available at the time of publication. The right is reserved to make changes at any time without notice.

COPYRIGHT© 1987
DEERE & COMPANY
Moline, Illinois
All rights reserved
A JOHN DEERE ILLUSTRATION
Previous Edition
Copyright© 1986 Deere & Company
Copyright© 1985 Deere & Company

T64;1331 16 310787

SECTION AND GROUP CONTENTS - Continued

SECTION 09 - STEERING SYSTEMS

Group 0960 - Power Steering

SECTION 15 - EQUIPMENT ATTACHING

Group 1511 - Drawbar

SECTION 16 - ELECTRICAL SYSTEM

Group 1671 - Batteries, Support, and Cables

Group 1672 - Alternator

Group 1674 - Wiring Harness and Switches

Group 1676 - Instruments and Indicators

SECTION 17 - FRAME, CHASSIS, OR SUPPORTING STRUCTURE

Group 1740 - Frame Installation

Group 1746 - Frame Bottom Guards

Group 1749 - Chassis Weights

Sprocket, Rear, and Bottom Counterweights

SECTION 18 - OPERATOR'S STATION

Group 1810 - Operator Enclosure

ROPS, Cab, Windshield Wiper Motor,

Operator Seat, and Backhoe Seat

SECTION 19 - SHEET METAL

Group 1910 - Hood or Engine Enclosure

Grille and Grille Housing, Engine Side

Shields, Cowl and Cowl Support

SECTION 30 - WINCH

Group 3015 - Controls Linkage

Group 3050 - Winch Drive and Clutches

Group 3060 - Winch Hydraulic System

Winch Control Valve and Hydraulic Pump

SECTION 31 - LOADER

Group 3102 - Buckets

Group 3103 - Forks

Group 3115 - Controls Linkage

Group 3140 - Frames

Group 3160 - Hydraulic System

Loader Cylinders, Hydraulic Pump and

Loader Control Valve

SECTION 32 - BULLDOZER

Group 3201 - Blades

Group 3215 - Controls Linkage

Group 3240 - Frames

Group 3260 - Hydraulic System

Hydraulic Return Filter, Reservoir, Pump,

Pump Drive, Dozer Control Valve, Auxiliary

Valve, Selector Valve, Flow Divider and

Bulldozer Cylinders

SECTION 33A - BACKHOE - 9300

Group 3300A - Removal and Installation

Group 3302A - Bucket

Group 3315A - Controls Linkage

Group 3340A - Frames

Group 3360A - Hydraulic System

Control Valve, Lift Check, Anti-Cavitation

Valve, Relief Valve, Manifold Block and

Backhoe Cylinders

SECTION 33B - BACKHOE - 9550

Group 3300B - Removal and Installation

Group 3302B - Bucket

Group 3315B - Controls Linkage

Group 3340B - Frames

Group 3360B - Hydraulic System

Control Valve, Lift Check, Anti-cavitation

Valve, Relief Valve, Manifold Block and

Backhoe Cylinders

SECTION 37 - LOG ARCH

Group 3740 - Arch Frames

SECTION 40 - WINCH DRIVE

Group 4051 - Gears, Shafts and Bearings

SECTION 42 - GROUND CONDITIONING TOOL

Group 4201 - Teeth and Shanks

Group 4240 - Frame

Group 4260 - Hydraulic System

SECTION 9005 - OPERATIONAL CHECK-OUT PROCEDURE

SECTION 9010 - ENGINE

Group 9010-05 - Theory of Operation

Group 9010-10 - System Operational Checks

Group 9010-15 - Diagnostic Information

Group 9010-20 - Adjustments

Group 9010-25 - Tests

Continued on next page

T64:1331 17 121185

<https://www.ebooklibonline.com>

Hello dear friend!

Thank you very much for reading.

Enter the link into your browser.

The full manual is available for immediate download.

<https://www.ebooklibonline.com>

SECTION AND GROUP CONTENTS—Continued

SECTION 9015 - ELECTRICAL SYSTEM

- Group 9015-05 - Theory of Operation
- Group 9015-10 - System Operational Checks
- Group 9015-15 - Diagnostic Information
- Group 9015-25 - Tests

SECTION 9020 - POWER TRAIN

- Group 9020-05 - Theory of Operation
- Group 9020-10 - System Operational Checks
- Group 9020-15 - Diagnostic Information
- Group 9020-20 - Adjustments
- Group 9020-25 - Tests

SECTION 9025 - HYDRAULIC SYSTEM

- Group 9025-05 - Theory of Operation
- Group 9025-10 - System Operational Checks
- Group 9025-15 - Diagnostic Information
- Group 9025-25 - Tests

SECTION 9030 - MISCELLANEOUS COMPONENTS

- Group 9030-05 - Theory of Operation
- Group 9030-15 - Diagnostic Information
- Group 9030-20 - Adjustments
- Group 9030-25 - Tests

SECTION 99 - DEALER FABRICATED TOOLS

INTRODUCTION

This technical manual is part of a twin concept of service.

FOS Manuals - for reference

Technical Manuals - for actual service

The two kinds of manuals work as a team to give you both the general background and technical details of shop service.

Fundamentals of Service (FOS) Manuals cover basic theory of operation, fundamentals of troubleshooting, general maintenance, and basic types of failures and their causes. FOS Manuals are for training new personnel and for reference by experienced technicians.

Technical Manuals are concise service guides for specific machines. Technical manuals are on-the-job guides containing only the vital information needed by an experienced service technician.

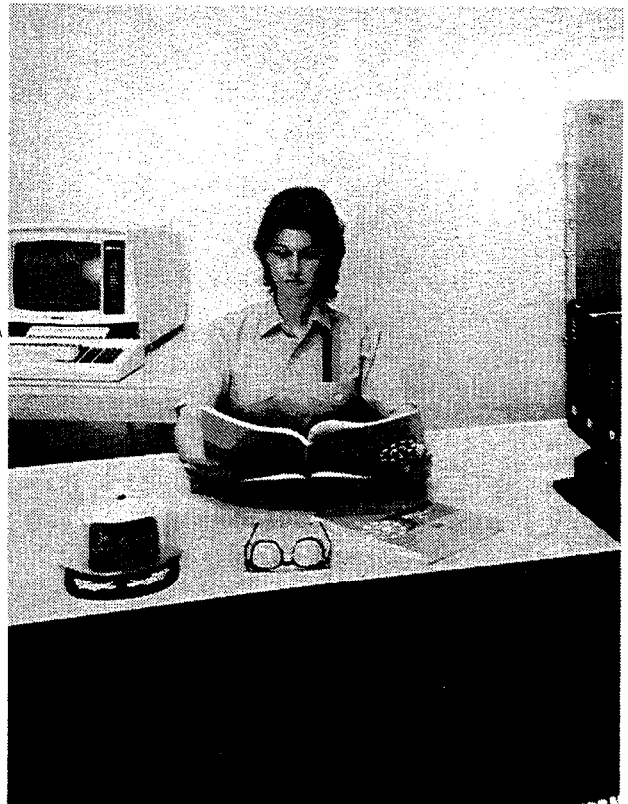

1TA;T5884BB, T82;SKPD HC 140984

FEATURES OF THIS TECHNICAL MANUAL

- John Deere ILLUSTRATION format emphasizing detailed pictures and fewer words in easy-to-use modules.
- Removal and installation groups preceding some repair groups.
- A section of system diagnostic testing.
- Table of contents of all sections at the front of the manual and a listing of all groups and headings at the front of each section.
- Essential tools and specifications listed at the front of each group they are used in.
- Essential tools illustrated in numerical order at end of manual.
- Alphabetical listing of all major components, specifications, and essential tools.
- Safety rules, general specifications, and lubrication specifications.

This technical manual was planned and written for you - an experienced service technician. Keep it in a permanent binder in the shop where it is handy. Refer to it when you need to know correct service procedures or specifications.

Using the technical manual as a guide will reduce error and costly delay. It will also assure you the best in finished service work.

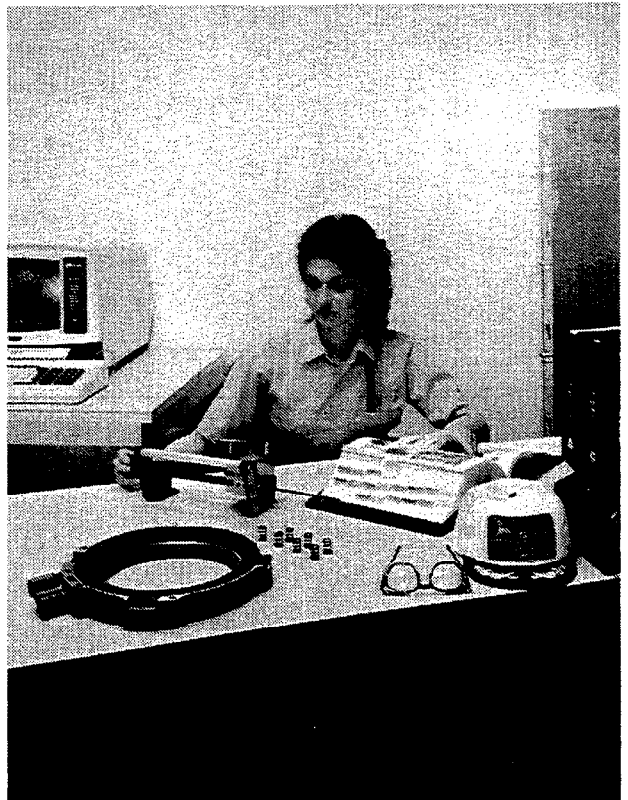

1TA;T5884BC T82;SKPD HD 140984

USING TABS

To fully utilize this technical manual, you must understand how it is organized.

Only two tab colors are used—gray and yellow. Each color represents a different type of information.

Spend a minute reading this now and save many minutes of searching later.

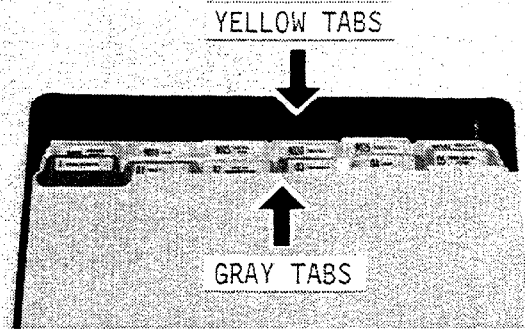

1TA;T5933AB T82;SKPD HE 120984

GRAY TAB SECTIONS

The gray tab sections are repair sections that tell how to repair the components of the various systems.

Repair of a component includes:

- Removal from machine (when necessary)
- Disassembly
- Inspection
- Replacement of parts
- Assembly
- Adjustment
- Installation on machine (when necessary)

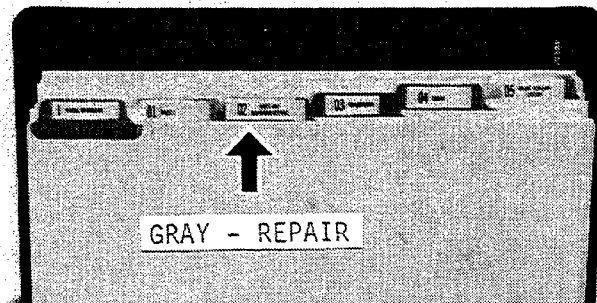

The numbers used for the repair (gray tab) sections are part of an overall service publication numbering system. The numbers identify the same sections in the parts catalog, flat rate manual, service information bulletins, and service training courses.

1TA;T5933AC T82;SKPD HF 120984

YELLOW TAB SECTIONS

Each yellow tab section contains information on:

Groups	
05	Theory of Operation
10	System Operational Checks
15	System Diagnostic Information
20	Adjustments
25	Tests

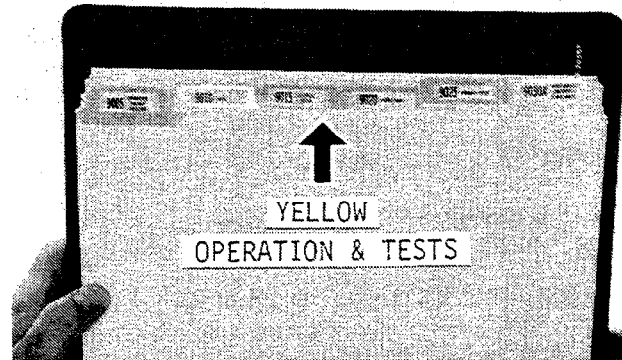

1TA;T5933AD T82;SKPD HG 190984

TAB POSITIONS

Each gray tab and its corresponding yellow tab have the same tab position. This is to help you quickly locate the related information.

Tab Color	Tab Position	Section No.	Description
Gray	4th	03	Transmission Repair
Yellow	4th	9020	Power Train Operation and Tests

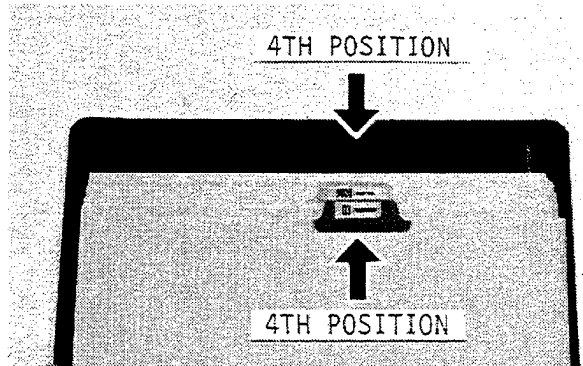

1TA;T5933AA T82;SKPD HH 120984

THREE-STEP PROCEDURE

Use the following three-step procedure to locate the desired information.

1. Determine the type of information you need. Is it repair, operation, or tests?
2. Go to the appropriate section tab:
Gray for Repair
Yellow for Operation or Tests

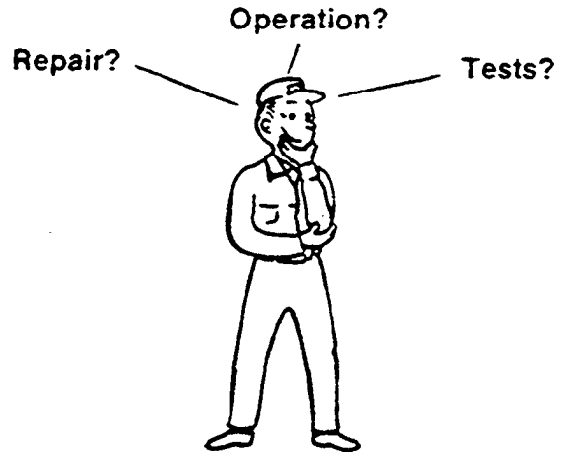

TYPE OF INFORMATION?

1TA;T5940AT T82;SKPD HI 120984

3. Use the table of contents on the first page of the section to locate the information.

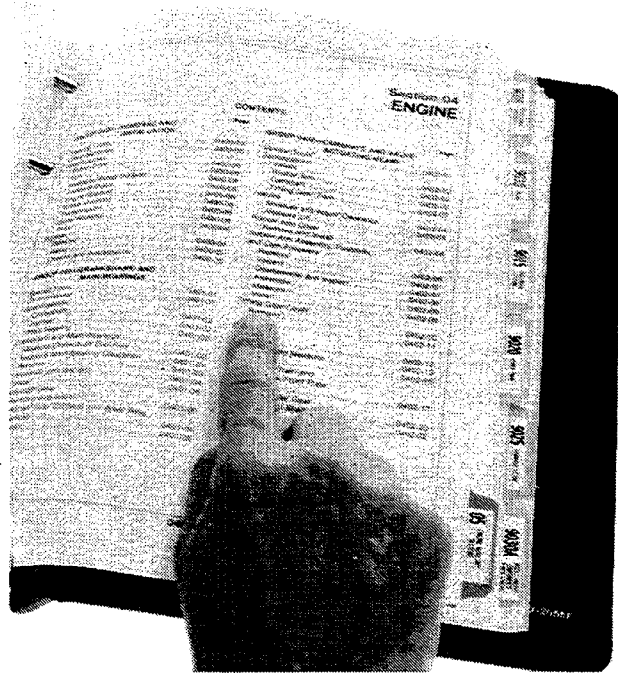

1TA:T5933AF T82;SKPD HJ 140984

SAFETY AND YOU



CAUTION: This safety symbol is used for important safety messages. When you see this symbol, follow the safety message to avoid personal injury.



30A:T81389 T28;I102 140984

AVOID FIRE HAZARDS

Be prepared if an accident or fire should occur. Know where the first aid kit and the fire extinguishers are located — know how to use them.

Do not smoke while refueling or handling highly flammable material.

Shut off the engine when refueling.

Use care in refueling if the engine is hot.

Do not use open pans of gasoline or diesel fuel for cleaning parts. Use good commercial, nonflammable solvents.

Provide adequate ventilation when charging batteries.

Do not check battery charge by placing metal objects across the posts.

Do not allow sparks or open flame near batteries.

Do not smoke near battery.

Never check fuel, battery electrolyte, or coolant levels with an open flame.

Never use an open flame to look for leaks anywhere on the equipment.

Never use an open flame as light anywhere on or around the equipment.

When preparing engine for storage, remember that inhibitor is volatile and therefore dangerous. Seal and tape openings after adding the inhibitor. Keep container tightly closed when not in use.

Inspect electrical wiring for worn or frayed insulation. Install new wiring if wires are damaged.



UNDERSTAND CORRECT MACHINE OPERATION AND SERVICE

Only qualified people should operate and service the machine.

Learn the location and purpose of all controls, instruments, indicators, and labels.

Be sure you understand a service procedure before you work on the machine.

Unauthorized modifications to the machine may impair the function and/or safety and affect machine life.

If it is necessary to make checks with the engine running, ALWAYS USE TWO PEOPLE — with the operator at the controls, able to see the person doing the checking.

KEEP HANDS AWAY FROM MOVING PARTS.



88A:T87358 T82:EXSA AG 130684

WEAR PROTECTIVE CLOTHING

Wear fairly tight clothing . . . and safety equipment.



44A:T85056 T82:EXSA B 060684

PROTECT AGAINST NOISE

Prolonged exposure to loud noise can cause impairment or loss of hearing. Wear a suitable hearing protective device such as earmuffs (A) or earplugs (B) to protect against objectionable or uncomfortable loud noise.



88A:X7662 T82:BHSA E 070684

AVOID HIGH-PRESSURE FLUIDS

Escaping fluid under pressure can penetrate the skin causing serious injury. Relieve pressure before disconnecting hydraulic or other lines. Tighten all connections before applying pressure. Keep hands and body away from pinholes and nozzles which eject fluids under high pressure. Use a piece of cardboard or paper to search for leaks.

If ANY fluid is injected into the skin, it must be surgically removed within a few hours by a doctor familiar with this type injury or gangrene may result.

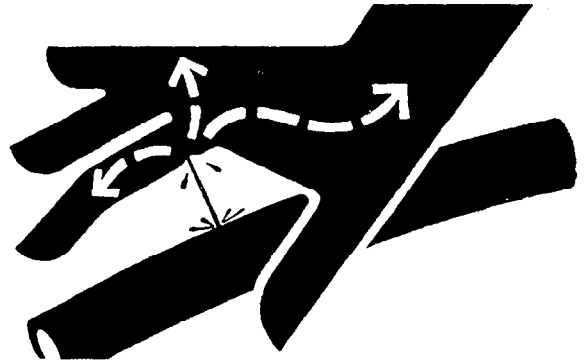

44A;X9821 T82;BNSA F 140984

PREVENT MACHINE RUNAWAY

Avoid possible injury or death from machine runaway.

Do not start engine by shorting across starter terminals. Machine will start in gear and will move if normal circuitry is bypassed.

NEVER start engine while standing on ground. Start engine only from operator's seat, with transmission in neutral, neutral-lock lever in LOCK position and brake lock lever engaged.



AB6;TS177 T82;CRSA AV 030185

USE A SAFETY CHAIN

A safety chain will help control drawn equipment (B) should it accidentally separate from the drawbar (A) while transporting. Using the appropriate adapter parts, attach the chain to the tractor drawbar support or other specified anchor location. Provide only enough slack in the chain to permit turning. See your John Deere dealer for a chain with a strength rating equal to or greater than the gross weight of the towed machine.

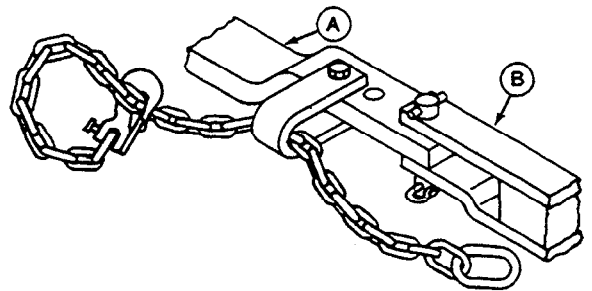

AB6;TS163 053;CHAIN 310884

USE SEAT BELT PROPERLY

Use a seat belt when you operate with a roll-over protective structure (ROPS) to minimize chance of injury from an accident such as an overturn.

Do not use a seat belt if operating without a ROPS.

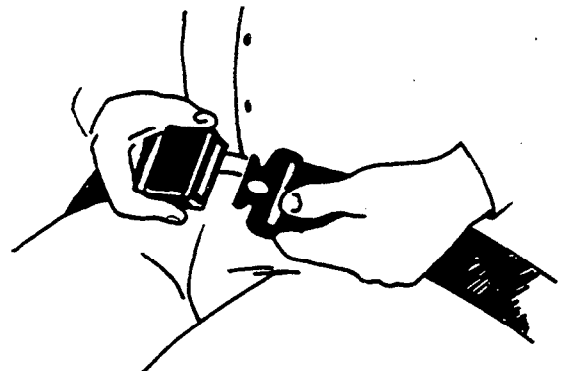

AB6;TS175 053;ROPS1 261184

KEEP RIDERS OFF MACHINE

Only allow the operator on the machine. Keep riders off.

Riders on a machine are subject to injury such as being struck by foreign objects and being thrown off of the machine. Riders also obstruct the operator's view resulting in the machine being operated in an unsafe manner.



AB6;TS173 053;RIDER 261184

HANDLE STARTING FLUID SAFELY

If your machine is equipped with a starting fluid starting aid, remember starting fluid is highly flammable. DO NOT incinerate or puncture a starting fluid container. DO NOT store a starting fluid container in a high-temperature area.



44A;T90207 T82;CRSA G 070684

PROTECT AGAINST FLYING DEBRIS

When you drive connecting pins in or out, guard against injury from flying pieces of metal or debris. Wear goggles or safety glasses and hard hat.

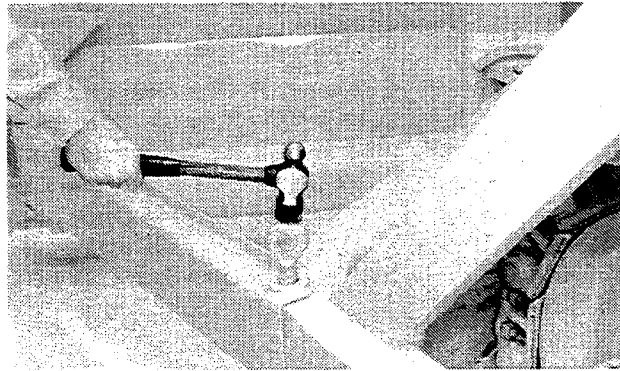

88A;T90211 T82;CRSA K 040984

SUPPORT RAISED EQUIPMENT

Do not work under raised equipment unless it has a support under it.

On crawler loaders, use the boom safety lock bar (A) stored in the battery compartment.

If a support is not available, lower equipment to the ground.

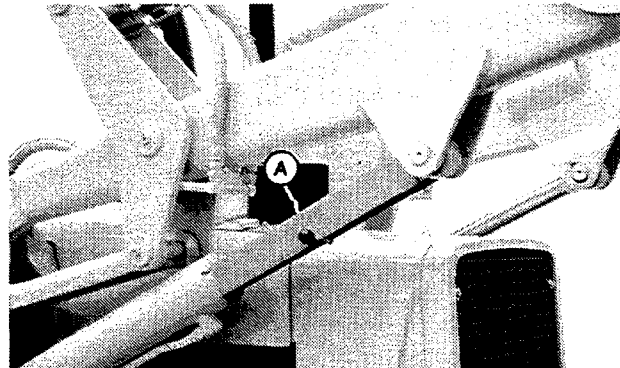

88A;T91444 82;CRSA AQ 051284

KEEP ROPS INSTALLED PROPERLY

Make certain all parts are reinstalled correctly if the roll-over protective structure (ROPS) is loosened or removed for any reason. Tighten mounting bolts to proper torque.

The protection offered by ROPS will be impaired if ROPS is subjected to structural damage, is involved in an overturn incident, or is in any way altered. A damaged ROPS should be replaced, not reused.

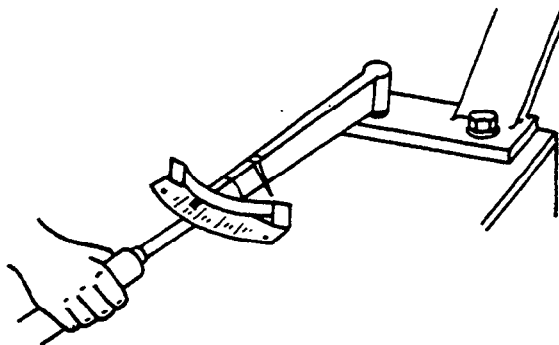

AB6;TS176 053;ROPS3 261184

TEST COOLANT HEATER IN LIQUID ONLY

Do not plug coolant heater into electrical power unless heating element is immersed in coolant. Sheath could burst and result in personal injury.

Use a heavy-duty grounded cord to connect coolant heater to electrical power.

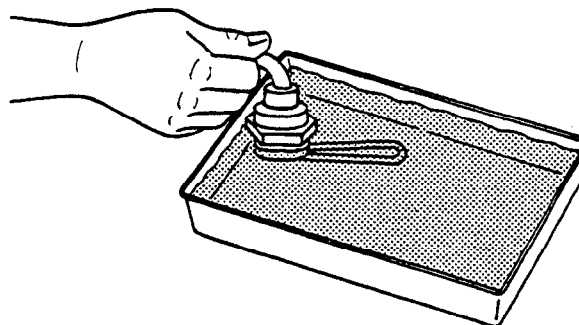

AB6;TS174 053;HEAT 110584

CLEAN THE MACHINE REGULARLY

Remove any grease, oil or debris build-up to avoid possible injury or machine damage.

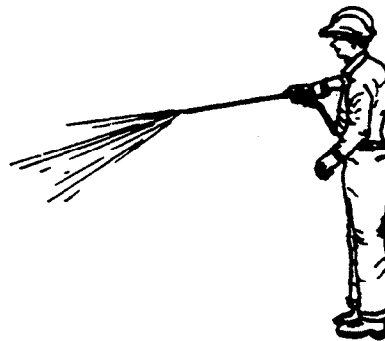

000;T5813AM T82;CRSA AH 051284

PREPARE MACHINE FOR REPAIR

1. Lower all equipment to the ground.
2. Move gear shift lever to the neutral "N" position.
3. Turn neutral lock lever to the lock position.
4. Apply and lock foot brake.
5. Stop the engine.
6. Operate all hydraulic control levers to release hydraulic pressure in the system.
7. Disconnect negative (-) battery cable.

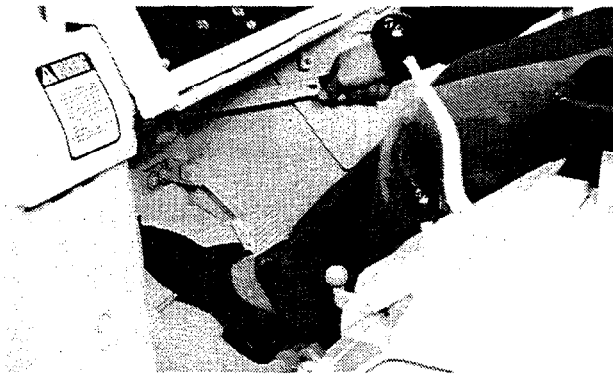

000;T6012BAT82;CRSA BA 080185

Group II Specifications

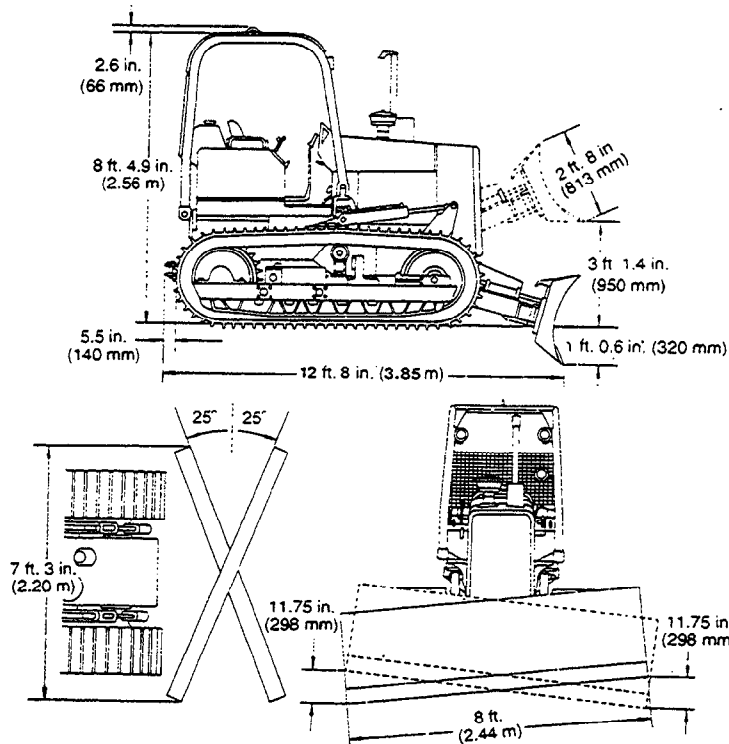

550B Crawler Tractor With 6405 Blade

000;T6026AA T82;CRSP AD 030185

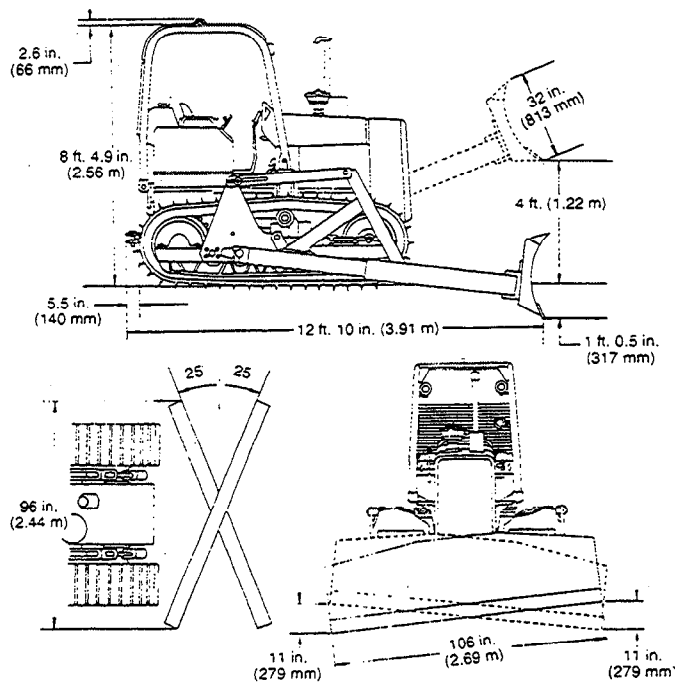

550B Crawler Tractor With 6410 Blade

000;T6020AM T82;CRSP AA 030185

Specifications

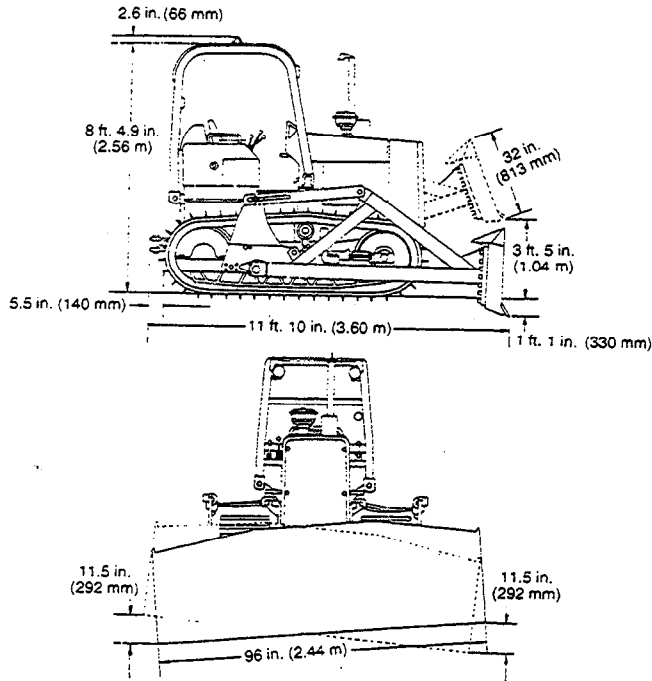

550B Crawler Tractor With 6415 Blade

000;T6020AP T82;CRSP AB. 030185

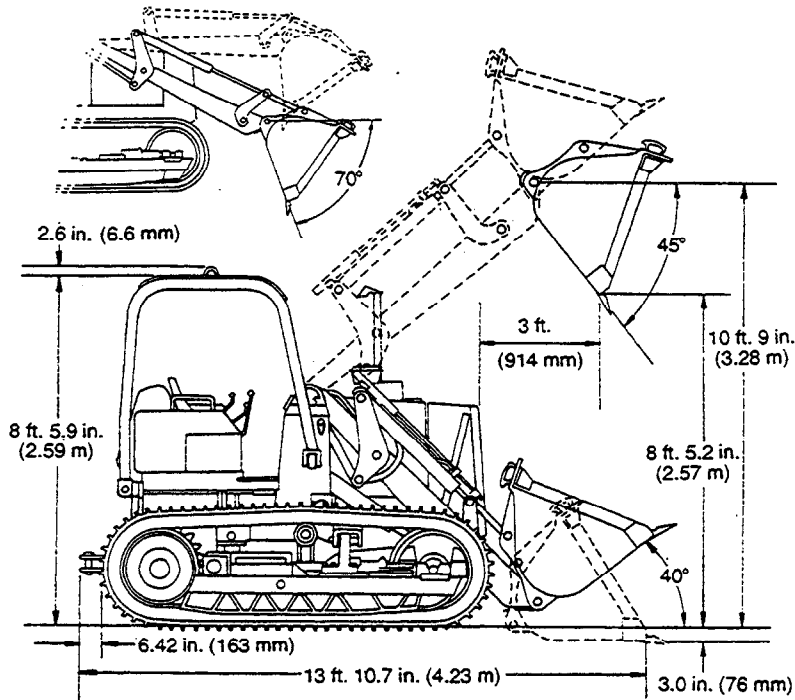

550B Crawler Loader

00A;T92275 T82;CRSP L 030185

Specifications

Travel Speeds:

When engine speed is 2200 rpm, machine travel speed will be:

Gear	Forward (550B)	Reverse (550B)	Forward (555B)	Reverse (555B)
1	2.05 mph (3.30 km/h)	2.44 mph (3.93 km/h)	2.01 mph (3.23 km/h)	2.42 mph (3.89 km/h)
2	3.34 mph (5.37 km/h)	3.96 mph (6.37 km/h)	3.26 mph (5.25 km/h)	3.90 mph (6.28 km/h)
3	5.73 mph (9.22 km/h)	6.80 mph (10.94 km/h)	5.63 mph (9.06 km/h)	6.28 mph (10.86 km/h)

T82;CRSP AW 220285

Group III Torque Values



HARDWARE TORQUE SPECIFICATIONS

Check cap screws and nuts, to be sure they are tight. If hardware is loose, tighten it to torque shown on the following charts unless a special torque is specified.

T82;CRMA EC 101284

NOTE: Torques shown are for dry (no lubrication on threads) hardware.

NOTE: Torque wrench tolerance is ± 10 per cent of specified torque.

Cap Screw Size-Inches	Customary Hardware					
	 Grade B		 Grade D		 Grade F	
	lb-ft.	(N-m)	lb-ft.	(N-m)	lb-ft.	(N-m)
1/4	----	----	10	(14)	14	(19)
5/16	----	----	20	(27)	30	(41)
3/8	----	----	35	(47)	50	(68)
7/16	35	(47)	55	(75)	80	(108)
1/2	55	(75)	85	(115)	120	(163)
9/16	75	(102)	130	(176)	175	(237)
5/8	105	(142)	170	(230)	240	(325)
3/4	185	(251)	300	(407)	425	(576)
7/8	160	(217)	445	(603)	685	(929)
1	250	(339)	670	(908)	1030	(1396)
1-1/8	330	(447)	910	(1234)	1460	(1979)
1-1/4	480	(651)	1250	(1695)	2060	(2793)

44A;T88884 T82;EXMA S 120684

Torque Values

METRIC HARDWARE TORQUE CHART

NOTE: Torques shown are for hardware with SAE30W oil on threads.

NOTE: Torque wrench tolerance is ± 10 percent of specified torque.

Metric Standard Thread

Thread	8.8		10.9		12.9	
	N·m	(lb-ft)	N·m	(lb-ft)	N·m	(lb-ft)
M5	5.9	(4.4)	7.9	(5.8)	9.8	(7.2)
M6	9.8	(7.2)	13.8	(10.2)	16.7	(12.3)
M8	24.6	(18.1)	34.4	(25.4)	40.2	(29.6)
M10	48.1	(35.5)	67.8	(50.0)	81.5	(60.1)
M12	84.4	(62.2)	118.0	(87.0)	142.0	(105.0)
M14	133.0	(98.0)	187.0	(138.0)	226.0	(167.0)
M16	206.0	(152.0)	290.0	(214.0)	348.0	(257.0)
M18	285.0	(210.0)	398.0	(294.0)	476.0	(351.0)
M20	402.0	(296.0)	570.0	(420.0)	677.0	(499.0)
M22	540.0	(398.0)	765.0	(564.0)	914.0	(674.0)
M24	697.0	(514.0)	980.0	(723.0)	1180.0	(870.0)

Metric Fine Thread

Thread	8.8		10.9		12.9	
	N·m	(lb-ft)	N·m	(lb-ft)	(N·m)	(lb-ft)
M8 x 1	26.5	(19.5)	37.3	(27.5)	44.2	(32.6)
M10 x 1	47.1	(34.7)	68.8	(50.7)	81.5	(60.1)
M12 x 1.5	88.4	(65.2)	123.0	(91.0)	147.0	(108.0)
M14 x 1.5	147.0	(108.0)	206.0	(152.0)	246.0	(181.0)
M16 x 1.5	221.0	(163.0)	309.0	(228.0)	373.0	(275.0)
M18 x 1.5	319.0	(235.0)	451.0	(333.0)	540.0	(398.0)
M20 x 1.5	451.0	(333.0)	628.0	(463.0)	755.0	(557.0)
M22 x 1.5	599.0	(442.0)	845.0	(623.0)	1030.0	(760.0)
M24 x 2	765.0	(564.0)	1080.0	(796.0)	1275.0	(940.0)
M26 x 2	1130.0	(833.0)	1570.0	(1158.0)	1915.0	(1412.0)

T82;EXMA T 290384

O-RING BOSS FITTING SERVICE RECOMMENDATIONS

1. Inspect boss O-ring seat. It must be free of dirt and defects. If repeated leaks occur, inspect for defects with a magnifying glass. Some raised defects can be removed with a slip stone.

Occasionally a lower durometer O-ring will seal against a rough seat. If neither of these solutions work, the component must be replaced.

2. Lubricate O-ring using petroleum jelly. Put a thimble over the threads to protect O-ring from nicks. Slide O-ring over the thimble and into the turned down section of fitting.

For angle fittings, loosen special nut and push special washer against threads so O-ring can be installed into the turned down section of fitting.

3. Turn fitting into the boss by hand until special washer or washer face (straight fitting) contacts boss face and O-ring is squeezed into its seat.

4. To position angle fittings, turn the fitting counterclockwise a maximum of one turn.

5. Tighten straight fittings to the torque value shown in chart. For angle fittings, tighten the special nut to value shown in the chart while holding body of fitting with a wrench.

STRAIGHT FITTING OR SPECIAL NUT TORQUE (1)

Thread Size	Torque ¹		Number Of Flats ²
	N·m	(lb-ft)	
3/8-24 UNF	8	(6)	2
7/16-20 UNF	12	(9)	2
1/2-20 UNF	16	(12)	2
9/16-18 UNF	24	(18)	2
3/4-16 UNF	46	(34)	2
7/8-14 UNF	62	(46)	1-1/2
1-1/16-12 UN	102	(75)	1
1-3/16-12 UN	122	(90)	1
1-5/16-12 UN	142	(105)	3/4
1-5/8-12 UN	190	(140)	3/4
1-7/8-12 UN	217	(160)	1/2

1. Tolerance $\pm 10\%$.

2. To be used if a torque wrench cannot be used. After tightening fitting by hand, put a mark on nut and boss; then tighten special nut or straight fitting the number of flats shown.

SAE FOUR BOLT FLANGE FITTING SERVICE RECOMMENDATIONS

1. Inspect the sealing surfaces for nicks or scratches, roughness or out-of-flat condition. Scratches cause leaks. Roughness causes seal wear. Out-of-flat causes seal extrusion. If these defects cannot be polished out, replace the component.
2. Install the correct O-ring (and backup washer if required) into the groove using petroleum jelly to hold it in place.
3. For split flange; loosely assemble split flange halves, being sure that the split is centrally located and perpendicular to the port. Hand tighten cap screws to hold parts in place. Do not pinch O-ring.
4. For single piece flange; put hydraulic line in the center of the flange and install four cap screws. With the flange centrally located on the port, hand tighten cap screws to hold it in place. Do not pinch O-ring.
5. For both single piece flange and split flange, be sure the components are properly positioned and cap screws are hand tight. Tighten one cap screw, then tighten the diagonally opposite cap screw. Tighten the two remaining cap screws. Tighten all cap screws within the specified limits shown in the chart.

DO NOT use air wrenches. DO NOT tighten one cap screw fully before tightening the others. DO NOT overtighten.

SAE FOUR BOLT FLANGE FITTING TORQUE

Nominal Flange Size	Cap Screw Size ¹	Torque ²		(lb-ft)	
		Min.	Max.	Min.	Max.
1/2	5/16 - 18 UNC	20	31	(15)	(23)
3/4	3/8 - 16 UNC	28	54	(21)	(40)
1	3/8 - 16 UNC	37	54	(27)	(40)
1-1/4	7/16 - 14 UNC	47	85	(35)	(63)
1-1/2	1/2 - 13 UNC	62	131	(46)	(97)
2	1/2 - 13 UNC	73	131	(54)	(97)
2-1/2	1/2 - 13 UNC	107	131	(79)	(97)
3	5/8 - 11 UNC	158	264	(117)	(195)
3-1/2	5/8 - 11 UNC	158	264	(117)	(195)
4	5/8 - 11 UNC	158	264	(117)	(195)
5	5/8 - 11 UNC	158	264	(117)	(195)

1. SAE Grade 5 or better cap screws with plated hardware.
2. Tolerance $\pm 10\%$. The torques given are enough for the given size connection with the recommended working pressure. Torques can be increased to the maximum shown for each cap screw size if desired. Increasing cap screw torque beyond this maximum will result in flange and cap screw bending and connection failures.

T827LPD AC 040285

Torque Values

O-RING FACE SEAL (ORFS) FITTING SERVICE RECOMMENDATIONS

NOTE: Replace face seal O-ring whenever the fitting is disassembled.

1. Inspect the sealing surfaces for nicks or scratches, roughness, or out-of-flat condition. Scratches cause leaks. Roughness causes seal wear. Out-of-flat causes seal extrusion. If these defects cannot be polished out, replace the component.

2. Lubricate O-rings and male threads using petroleum jelly.

For O-ring face seal fittings, push O-ring into the groove.

For O-ring boss fittings, put a thimble over the threads to protect O-ring from nicks. Slide O-ring over the thimble and into the turned down section of fitting.

For angle fittings, loosen special nut and push special washer against threads so O-ring can be installed into the turned down section of fitting.

3. Install fitting and hand tighten until snug. To position angle fittings, turn fitting counterclockwise a maximum of one turn.

4. Tighten fitting or nut to torque value shown in chart per dash size stamped on fitting.

Use one wrench to hold connector body and another wrench to tighten nut. When tightening a fitting on a hose, it may be necessary to use three wrenches to prevent twisting hose; one on the connector body, one on the nut, and one on the body of hose fitting.

O-RING FACE SEAL FITTING TORQUE (1)

Nominal		Dash Size	Thread Size in.	O-Ring Face Seal End		Bulkhead Nut Torque		Thread Size in.	O-Ring Boss End	
Tube mm	O.D. in.			Swivel Nut Torque Nm	lb-ft	Nm	lb-ft		Straight Fitting or Jam Nut Torque Nm	lb-ft
4.76	0.188	-3	-----	----	----	----	----	3/8-24	8	6
6.35	0.250	-4	9/16-18	16	12	5.0	3.5	7/16-20	12	9
7.94	0.312	-5	-----	----	----	----	----	1/2-20	16	12
9.52	0.375	-6	11/16-16	24	18	9.0	6.5	9/16-18	24	18
12.70	0.500	-8	13/16-16	50	37	17.0	12.5	3/4-16	46	34
15.88	0.625	-10	1-14	69	51	17.0	12.5	7/8-14	62	46
19.05	0.750	-12	1 3/16-12	102	75	17.0	12.5	1 1/16-12	102	75
22.22	0.875	-14	1 3/16-12	102	75	17.0	12.5	1 3/16-12	122	90
25.40	1.000	-16	1 7/16-12	142	105	17.0	12.5	1 5/16-12	142	105
31.75	1.250	-20	1 11/16-12	190	140	17.0	12.5	1 5/8-12	190	140
38.10	1.500	-24	2-12	217	160	17.0	12.5	1 7/8-12	217	160

1. Tolerance: +15 -20%

CHECK TRACK SHOE TORQUE

Track shoe cap screws should be checked periodically for tightness.

Tighten cap screws to 120 lb-ft (163 N·m) torque.

NOTE: Replacement hardware should be lubricated and tightened to above specification.

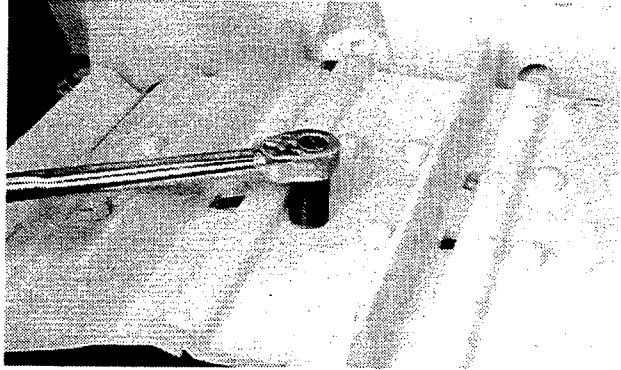

000;T6009AN T82;CRMA EO 181284

USE PERIODIC MAINTENANCE CHART

The chart and the operator's manual list all the service points and the procedures for maintaining the machine. Use them to check, service, and adjust your customer's machine.

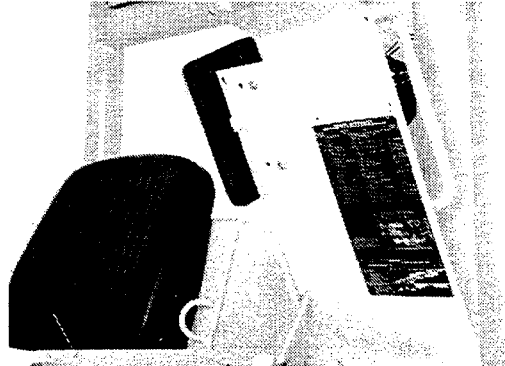

000;T6009AU T82;CRPD EG 070185

FUEL SPECIFICATIONS

Use **ONLY** clean, high-quality fuel.

Use Grade No. 2-D fuel above 40°F (4°C).

Use Grade No. 1-D fuel at temperatures below 40°F (4°C).

Use Grade No. 1-D fuel for all air temperatures at altitudes above 5000 ft (1 500 m).

IMPORTANT: If fuel sulfur content exceeds 0.5 per cent, the engine oil drain interval must be reduced by 50 per cent (to 100 hours).

Use fuel with less than 1.0 per cent sulfur. If possible, use fuel with less than 0.5 per cent sulfur.

For maximum filter life, sediment and water should not be more than 0.10 per cent.

The cetane number should be 40 minimum. If you operate your machine where air temperatures are normally low or where altitudes are high, you may need fuel with a higher cetane number.

Cloud Point—For cold weather operation, cloud point should be 10°F (6°C) below lowest normal air temperature.

T82;BHFL F 190784

FUEL STORAGE

NOTE: Diesel fuels stored for a long time may form gum and plug filters.

Keep fuel in a clean container in a protected area. Water and sediment must be removed before fuel gets to the engine. Do not use de-icers to remove water from fuel. Do not depend on fuel filters to remove water.

If possible, install a water separator at the storage tank outlet. See your John Deere dealer for this part.

IMPORTANT: Keep all dirt, scale, water or other foreign material out of fuel.

Store fuel drums on their sides with plug up.

T82;BHFL G 180584

ENGINE OIL

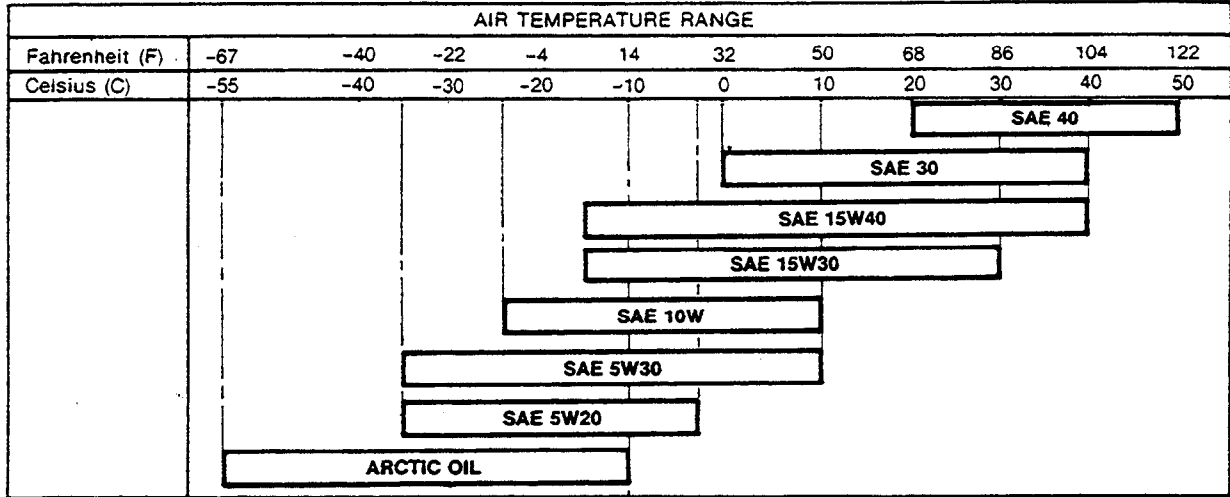

Depending upon the expected air temperature range between oil changes, use oil viscosity shown on the temperature chart above.

Additives are not required nor recommended.

John Deere TORQ-GARD SUPREME® engine oil is recommended. If other oils are used, they must have the following minimum specifications:

Oil Specification

Use

API Service CD/SC
(MIL-L-2104C)

Recommended.

API Service CC/SC*
or MIL-L-46152*

For SAE 5W20, SAE 5W30 and arctic oil only, use if recommended oil is not available.

MIL-L-46167*

For arctic oil only.

*Change oil at 100 hours, which is half the normal drain interval.

88A;T91372 T82;CRFL E 270483

TRANSMISSION—STEERING CLUTCHES AND HYDRAULIC OIL

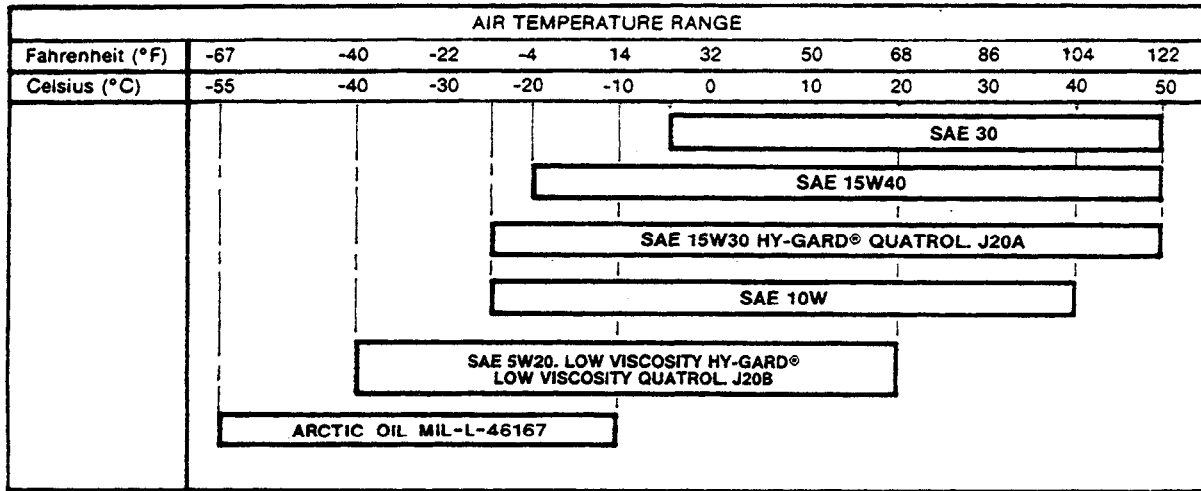

Depending upon the expected air temperature range between oil changes, use oil viscosity shown on the temperature chart above.

The following oils are recommended:

John Deere HY-GARD® Transmission and Hydraulic Oils.

Engine oil meeting API Service CD/SC (MIL-L-2104C), CC/SC, or MIL-L-46152 and T02 oil test.

You may also use QUATROL® oils, which are oils that meet John Deere standards, or other oils meeting John Deere Standard J20A or J20B.

Oil meeting MIL-L-46167 may be used as an arctic oil.

88A/T5925AX T82/CRFL M 061284

FINAL DRIVE OIL

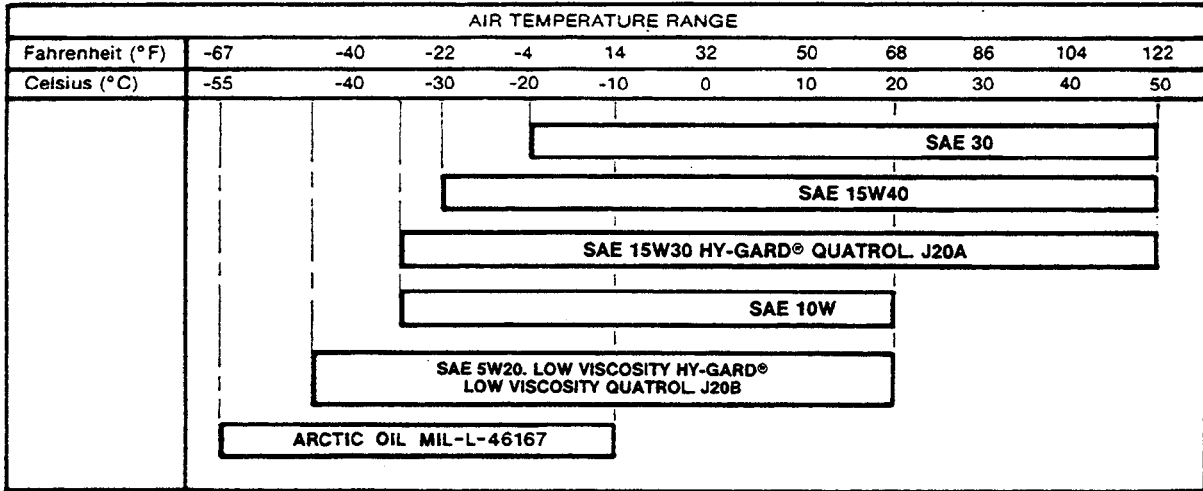

Depending upon the expected air temperature range between oil changes, use oil viscosity shown on the temperature chart above.

The following oils are recommended:

John Deere HY-GARD® Transmission and Hydraulic Oils.

Engine oil meeting API Service CD/SC (MIL-L-2104C), CC/SC, or MIL-L-46152 and T02 oil test.

You may also use QUATROL® oils, which are oils that meet John Deere standards, or other oils meeting John Deere Standard J20A or J20B.

Oil meeting MIL-L-46167 may be used as an arctic oil.

88A:T5935AY T82:CRFL N 130984

WINCH OIL

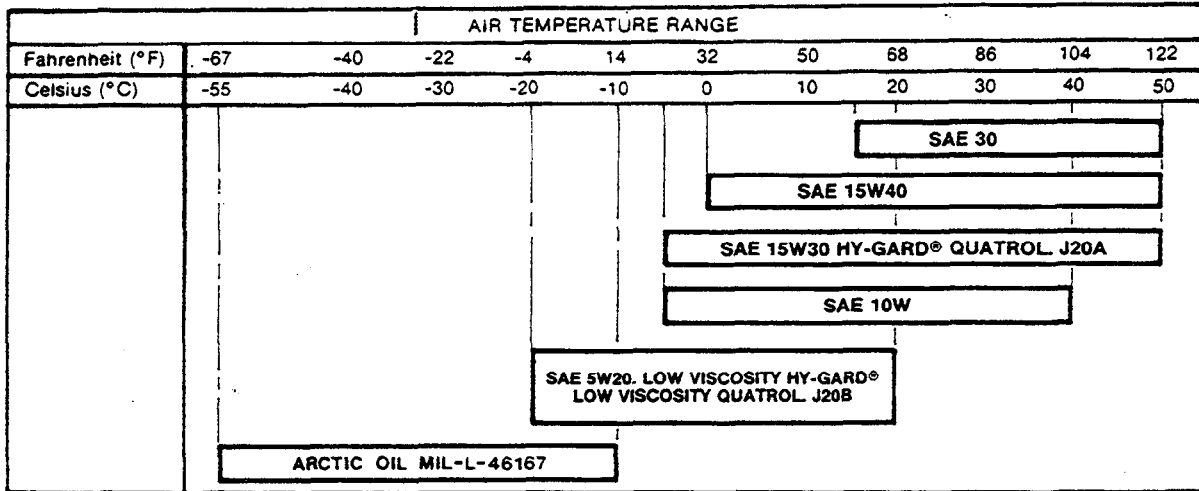

Depending upon the expected air temperature range between oil changes, use oil viscosity shown on the temperature chart above.

The following oils are recommended:

John Deere HY-GARD® Transmission and Hydraulic Oils.

Engine oil meeting API Service CD/SC (MIL-L-2104C), CC/SC, or MIL-L-46152 and T02 oil test.

You may also use QUATROL® oils, which are oils that meet John Deere standards, or other oils meeting John Deere Standard J20A or J20B.

Oil meeting MIL-H-5606A may be used as an arctic oil.

88A:T5935AZ T82:CRFL 0 130984

TRACK ROLLER, FRONT IDLER, AND CARRIER ROLLER OIL

Use SAE 80W90 gear oil meeting API Service GL-5 (MIL-L-2105B or MIL-L-2105C).

T82:CRFL 0 080483

GREASE

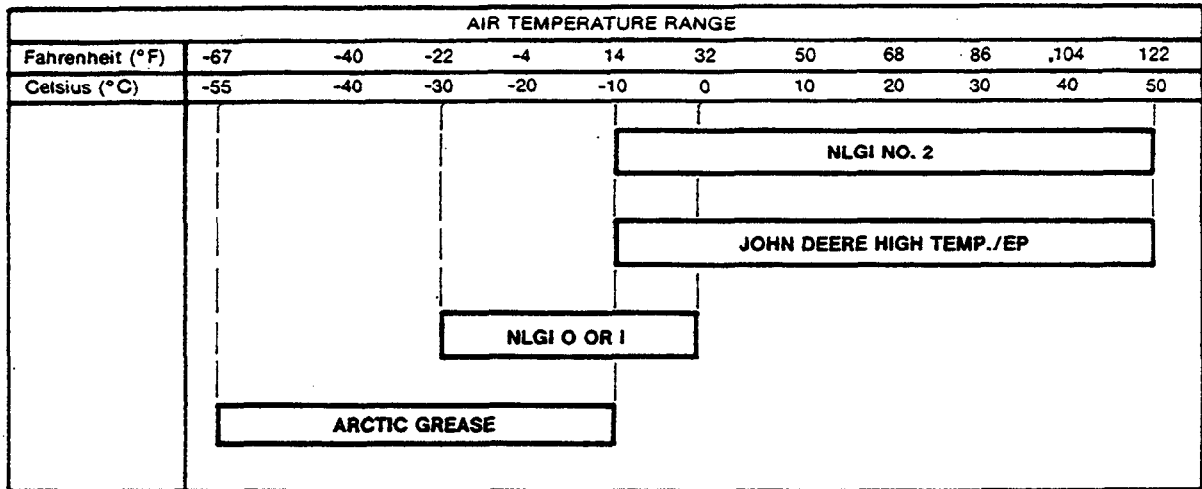

Depending on the expected air temperature range during use, use grease shown on chart above.

Greases recommended are:

SAE Multipurpose Grease with Extreme Pressure (EP) performance and containing 3 to 5 per cent molybdenum disulfide (preferred).

John Deere High Temperature/EP Grease.

SAE multi-purpose EP grease.

Grease meeting MIL-G-10924C specifications may be used as arctic grease.

44A/T91371 T82/CRFL F 140984

COLD WEATHER OPERATION

Additional information on cold weather operation is available from your John Deere dealer.

T82:BHFL E 150982

ALTERNATIVE FUELS AND LUBRICANTS

Conditions in certain geographical areas may require special fuels and/or lubricants which do not appear in this manual. If you have any questions, consult your John Deere dealer.

T82:BHFL I 020383

LUBRICANT STORAGE

Your machine can operate at top efficiency only if clean lubricants are used. Use clean containers to handle all lubricants. Store them in an area protected from dust, moisture, and other contamination. Store drums on their sides.

T82:BHFL J 080483

Section 01 TRACKS

CONTENTS

GROUP 0130 - TRACK SYSTEMS

Essential Tools	0130-01
Service Equipment and Tools	0130-01
Other Materials	0130-02
Specifications	0130-03
Track Chain	
Remove	0130-05
Disassemble	0130-07
Assemble	0130-11
Track Shoes	
Remove and Inspect	0130-16
Install	0130-16
Remove Drive Sprocket	0130-17
Remove Track Frame	0130-17
Upper Carrier Roller Assembly	
Remove	0130-18
Disassemble and Inspect	0130-19
Assemble	0130-20
Front Idler Assembly	
Remove	0130-21
Disassemble and Inspect	0130-21
Assemble	0130-22
Hydraulic Track Tension Adjuster	
Remove	0130-25
Disassemble and Inspect	0130-25
Assemble	0130-26
Remove Track Idler Recoil Spring	0130-26
Rack Guards	
Remove and Install	0130-28
Chain Guides	
Remove and Install	0130-29
Track Rollers	
Remove	0130-30
Disassemble	0130-30
Assemble	0130-31
Inspect and Repair Track Frame	0130-34
Install Track Components	
Track Rollers	0130-34
Idler Recoil Spring	0130-34
Hydraulic Track Tension Adjuster	0130-35
Front Idler Assembly	0130-35
Track Frame	0130-36
Drive Sprockets	0130-36
Upper Carrier Roller Assembly	0130-37
Track Chain	0130-39

Adjustments

Check Track Sag	0130-38
Adjust Track Sag	0130-39
Align Track	0130-40
Front Idler Horizontal	0130-41
Front Idler Vertical	0130-42
Measurements	
Link Height	0130-42
Track Bushing Outer Diameter	0130-43
Track Pitch	0130-43
Grouser Bar Height	0130-44
Front Idler Wear	0130-44
Sprocket Wear	0130-45
Upper Track Carrier Roller	0130-45
Track Roller	0130-46
Front Crossbar	
Remove and Inspect	0130-46
Install	0130-47
Rear Crossbar	
Remove and Inspect	0130-47
Install	0130-48

ESSENTIAL TOOLS

NOTE: Order tools from your SERVICE-GARD™ Catalog. Some tools may be available from a local supplier.

Number	Name	Use
JD-284	Hydraulic Track Adjuster Service Set	Install track adjuster seals.
T16678	Special Bolt	Remove and install track idler recoil spring.
JT30018	Seal Centering Fixture Tool	To install seal ring in front idler assembly.
JT30019	Seal Centering Fixture Tool	To install seal ring in front idler assembly.

T47;0130 6033DF 040285

SERVICE EQUIPMENT AND TOOLS

NOTE: Order tools from your SERVICE-GARD™ Catalog. Some tools may be available from a local supplier.

Name	Use
Master Pin Pusher	Remove master track pin.
Disks	Remove and install bushings.
35 mm	
39 mm	
60 mm	
63 mm	
66 mm	
71 mm	
Undercarriage Inspection Service Tool Kit	Measure undercarriage wear.
200 Ton Twin Head Track Press	Disassemble and assemble track chain
Track Press Tooling Set	Used with track press to disassemble and assemble track chain.

T47;0130 6033DG 040285

OTHER MATERIAL

Number	Name	Use
PT569	John Deere NEVER-SEEZ® Lubricant	Spray on threads of T16678 Special Bolt.
----	Low carbon AWS-ASTM, E-7018 electrode (5/32 in. dia.)	Weld on track frame wear strips.
T43512	John Deere LOCTITE® Thread Lock and Sealer (Medium Strength)	Apply to second through tenth threads of idler bracket to shaft screws.

*LOCTITE is a trademark of the Loctite Corp.
NEVER-SEEZ is a trademark of the Never-Seez Compound Corp.*

T47;0130 6033DH 040285

SPECIFICATIONS

Item	Measurement	Specification
Track shoe attaching cap screws	Torque	163 ± 27 N·m (120 ± 20 lb-ft)
Upper carrier roller plate socket head cap screws	Torque	54 ± 4 N·m (40 ± 3 lb-ft)
Upper carrier roller cover cap screws	Torque	47 N·m (35 lb-ft)
Upper carrier roller oil lever check cap screws	Torque	41 ± 4 N·m (30 ± 3 lb-ft)
Front idler seal ring socket head cap screws	Torque	68 ± 7 N·m (50 ± 5 lb-ft)
Front idler guide to idler bracket cap screws	Torque	163 ± 16 N·m (120 ± 12 lb-ft)
Track adjusting cylinder yoke to idler bracket cap screws	Torque	163 ± 16 N·m (120 ± 12 lb-ft)
Roller to track frame cap screws	Torque	175 ± 18 N·m (130 ± 13 lb-ft)
Inner roller bracket and idler bracket to shaft cap screws	Torque	407 ± 41 N·m (300 ± 30 lb-ft)
Outer roller and idler bracket to shaft (special cap screw)		
Part No. on head	Torque	407 ± 41 N·m (300 ± 30 lb-ft)
No marking on head	Torque	285 ± 28 N·m (210 ± 21 lb-ft)
Inner and outer rock guard cap screws	Torque	230 N·m (170 lb-ft)
Inner to outer rock guard spacer cap screws	Torque	163 ± 16 N·m (120 ± 12 lb-ft)
Drive sprocket to axle shaft cap screws	Torque	576 ± 57 N·m (425 ± 42 lb-ft)

Continued on next page

SPECIFICATIONS—Continued

Item	Measurement	Specification
Front crossbar to frame horizontal cap screws	Torque	339 ± 34 N·m (250 ± 25 lb-ft)
Front crossbar to frame vertical cap screws	Torque	475 ± 12 N·m (350 ± 35 lb-ft)
Front crossbar to track frame cap screws	Torque	576 ± 54 N·m (425 ± 40 lb-ft)
Rear crossbar bar bracket to steering clutch housing cap screws	Torque	407 ± 41 N·m (300 ± 30 lb-ft)
Dozer mounting frame to rear bar bracket cap screws	Torque	407—909 N·m (300-670 lb-ft)
Rear crossbar bracket cap to rear bar bracket cap screws	Torque	339 ± 40 N·m (250 ± 25 lb-ft)
Rear crossbar locking collar to track frame cap screws	Torque	909 ± 95 N·m (670 ± 70 lb-ft)
Rear crossbar retainer to locking collar and track frames ..	Torque	231 ± 23 N·m (170 ± 17 lb-ft)
Track chain	Distance across four links:	
	New chain	640.1 mm (25.2 in.)
	100% wear limit	652.8 mm (25.7 in.)
Track chain link	Height:	
	New chain	90 mm (3.54 in.)
	100% wear limit	82.8 mm (3.26 in.)
Track chain bushing	O.D.:	
	New bushing	51 mm (2.01 in.)
	100% wear limit (normal loading)	46 mm (1.81 in.)
	100% wear limit (high shock loading)	48 mm (1.89 in.)
	Stick out	7.44 mm (0.298 in.)

Continued on next page

T47;0130 6033DJ 190285

Track Systems

SPECIFICATIONS—Continued

Item	Measurement	Specification
Track shoe single grouser bar ...	Height:	
	New shoe	48 mm (1.89 in.)
	100% wear limit	20 mm (0.79 in.)
Track shoe semi-grouser bar	Height:	
	New shoe	21.1 mm (0.83 in.)
	100% wear limit	12 mm (0.47 in.)
Upper track carrier roller	O.D.:	
	New roller	152.4 mm (6 in.)
	100% wear limit	139.7 mm (5.5 in.)
Track roller	O.D.:	
	New roller	182.6 mm (7.19 in.)
	100% wear limit	168.2 mm (6.62 in.)
Front idler flange	Height:	
	New idler	19.3 mm (0.76 in.)
	100% wear limit	24.4 mm (0.96 in.)
Upper carrier roller shaft	Height above face of seal bore ..	145.03—145.54 mm (5.710—5.730 in.)
Front idler assembly bushing	Dimension below face of roller ..	0.79 mm (0.031 in.)
Track chain	Sag between rear sprocket and carrier roller	22.23—28.58 mm (7/8—1-1/8 in.)

T47;0130 6033DK 190285

REMOVE TRACK CHAIN

1. Rotate track to position the master pin on the front idler as shown.

NOTE: Master pin is identified by drill point in end of pin.



CAUTION: Make sure track clears floor before rotating.

2. Remove two track shoes; one on each side of master pin.

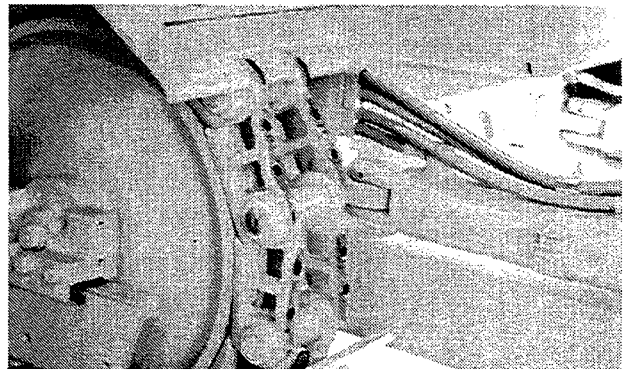

2AG;T93554 T47;0130 30 220783

3. Release track tension by loosening nut (A) and turn set screw (B) out of the track adjusting cylinder (C) approximately three turns.

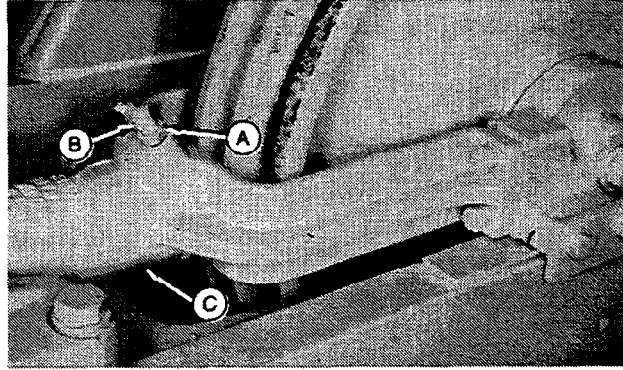

2AG;T93555 T47;0130 31 220783

IMPORTANT: Do not remove the track master pin with a hammer. This will enlarge the link pin bore requiring installation of a new track link.

4. Remove master pin from track link using master pin pusher. Install aligning adapter (A) into master pin pusher C-frame securing with holding screw (B). Put aligning bushings (C) over forcing pin (D) and install adapter (E) in C-frame.

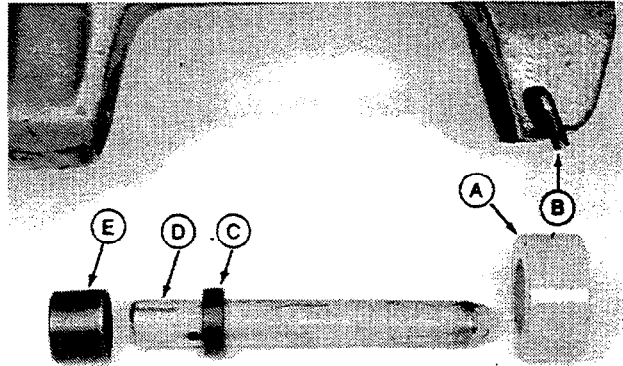

- A—Aligning Adapter
- B—Holding Screw
- C—Aligning Bushing
- D—Forcing Pin
- E—Pin Adapter

2AG;T93556 T47;0130 6033DL 040285

Track Systems

5. Position master pin pusher and forcing pin in alignment with master pin using load positioning sling and hoist.

6. Turn ram adjusting screw (B) clockwise with crank until forcing pin (A) contacts master pin.

7. Connect hand pump to pin pusher. Activate pump to remove master pin.

8. Remove forcing pin to separate track.

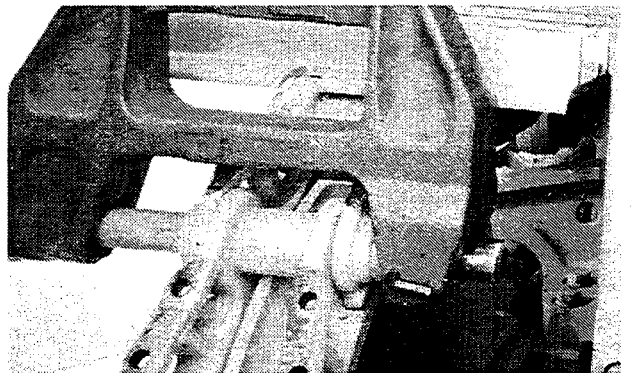
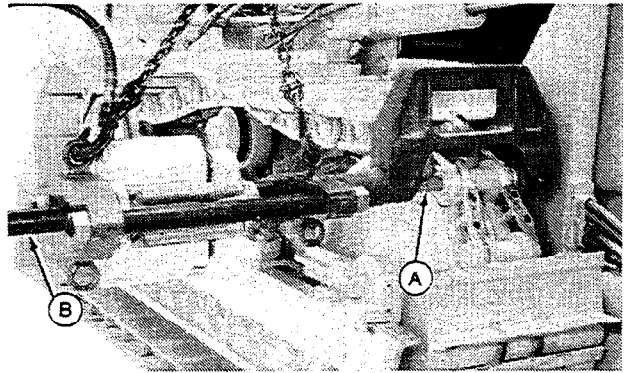

2AG:T93557,T93644 T47:0130 33 220783

9. Pull track chain apart. Remove spacers (B) and seals (A) from between left and right track links.

10. Lift side of machine or operate crawler and rotate track in the reverse direction. Slowly, unwrap track off drive sprocket.

11. Place a jack under both crossbars and raise crawler to provide clearance. Block crawler up securely.

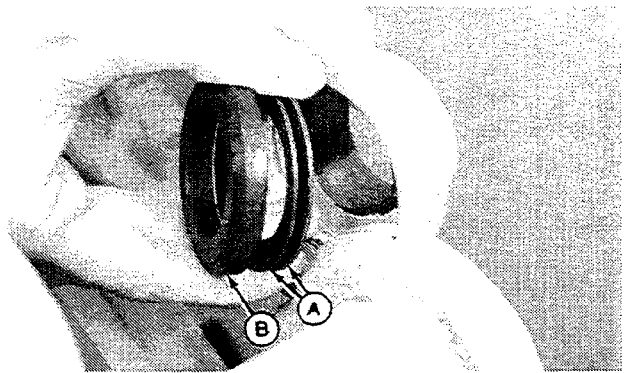

2AG:T93558 T47:0130 34 220783

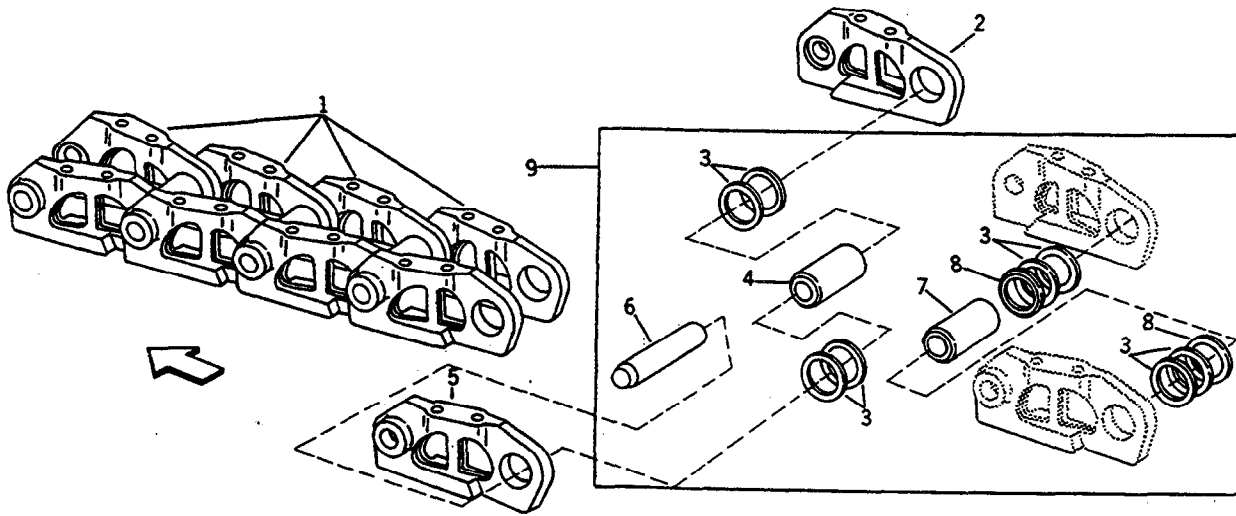

T59376F

1—Track Chain
2—Right Track Link
3—Belleville Seals

4—Bushing
5—Left Track Link

6—Pin, Standard
Pin, Master
(Drill Point On End)

7—Master Bushing
8—Spacer (Master Bushing)
9—Pin and Bushing Repair Kit

2AG;T59376 T47;0130 03 220783

DISASSEMBLE TRACK CHAIN

⚠ CAUTION: Always wear safety glasses when operating press. Parts may break or chip, causing eye injuries.

1. Remove track shoes from chain.

T47;0130 6033DM 040285

Track Systems

NOTE: Part numbers shown are from 26815 Tooling Set.

2. Install saddle (A) from 26815 Track Disassembly and Assembly Tooling Kit in track press frame.

3. Adjust conveyor extension to desired conveyor working height.

4. Install left and right disassembly plates, sleeves and components from tooling set on work head of press and secure with attaching nuts.

- A—(40989) Saddle
 - B—(26819) R.H. Disassembly Adapter Plate
 - C—(26327) Master Bushing Spacer (2 used)
 - D—(33266) Forcing Pin (2 used)
 - E—(10153) Set Screw (2 used)
 - F—(10103) Cap Screw (2 used)
 - G—(26429) Forcing Pin Sleeve (2 used)
 - H—(21887) Spacer (2 used)
 - I—(20636) Spacer (2 used)
 - J—(26820) L. H. Assembly Adapter Plate
- Track Disassembly Tooling

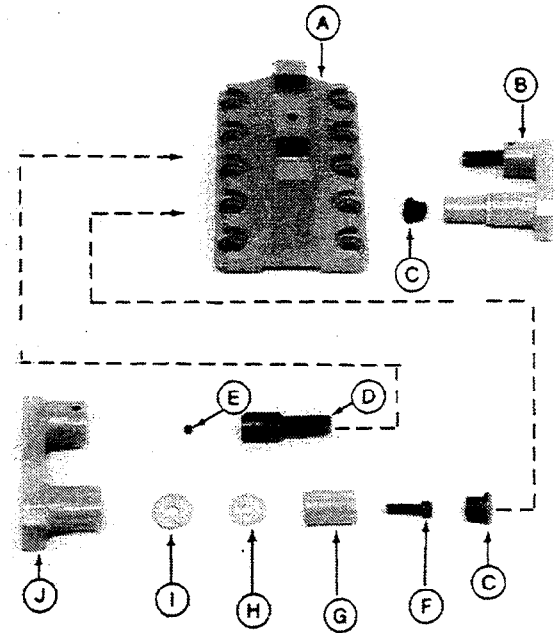

2AG:T94573 T47:0130 6033DN 040285

NOTE: If pins and bushings are to be turned and not replaced, be sure one end of each pin and bushing is marked prior to chain disassembly. The mark can then be referenced during assembly to insure an exact 180° turn.

T47:0130 06 220783

5. Position track chain on track press conveyor with cap screw hole side up.

6. Raise the elevating conveyor and advance the track chain assembly until the link assembly bushing end is directly over the saddle front seat.

7. Lower conveyor so the chain link assembly is in position over the saddle.

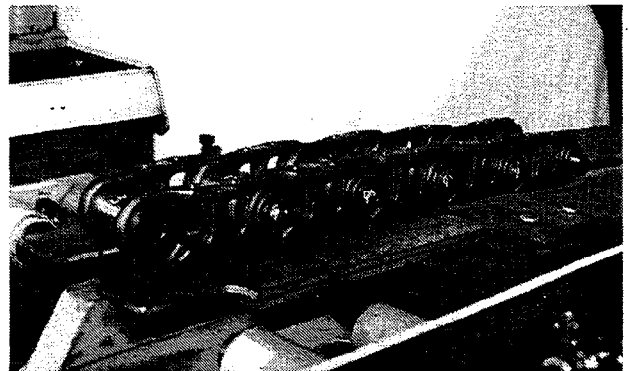

2AG:T95438 T47:0130 07 220783

Track Systems

NOTE: When removing master bushing, insert Master Bushing Spacers (A) in bushing forcing sleeve. Remove spacer after removing bushing.

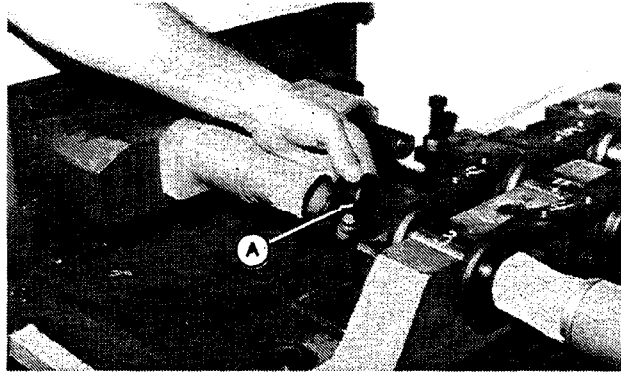

2AG;T94575 T47;0130 603300 040285

8. Advance right hand work head until it contacts pin and bushing. Check alignment of tooling with pin and bushing. Press pin and bushing from link.

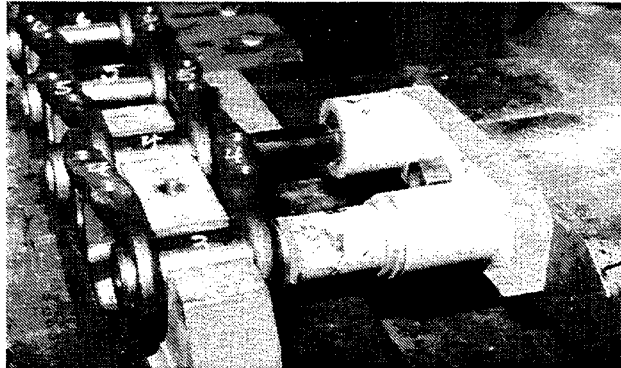

2AG;T94576 T47;0130 09 190883

9. Retract the right ram. This action will carry the right side link with the ram. Remove the link (A) and two belleville seals (B). Seals should be discarded and replaced with new ones when reassembling.

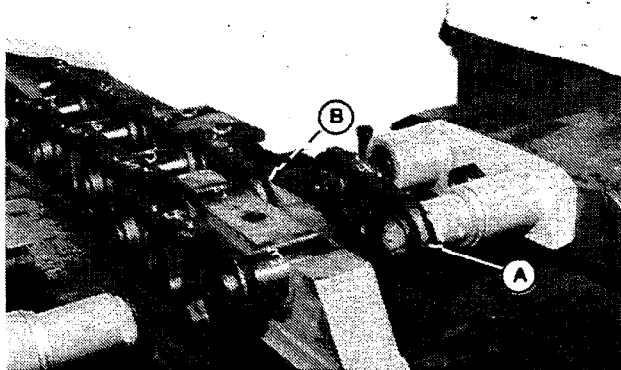

2AG;T94577 T47;0130 10 190883

10. Advance the left work head of track press until the ram and disassembly adapter come in contact with bushing and pin. Check for proper alignment of tooling with bushing and pin. Press bushing, belleville seals, and pin from left-hand track link.

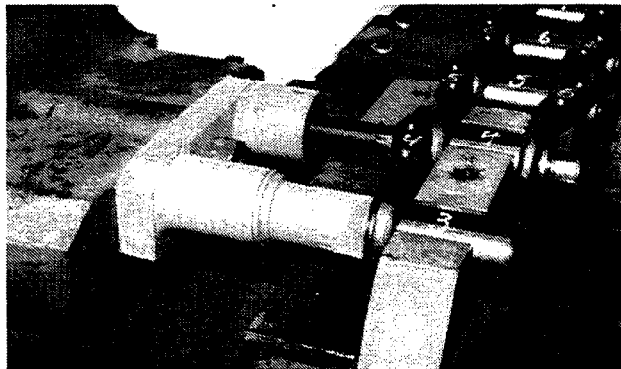

2AG;T94578 T47;0130 11 040285

Track Systems

11. Retract the left ram carrying the left side link. Remove the link and two belleville seals.

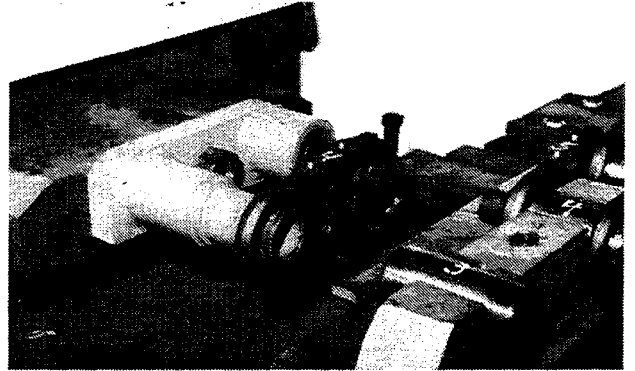

2AG;T94579 T47;0130 12 220783

12. Raise elevating table and remove bushing (A) and pin (B).

13. Advance the track chain in position over the saddle.

14. Lower conveyor to rest chain link assembly into saddle.

15. Disassemble remainder of track chain using this method.

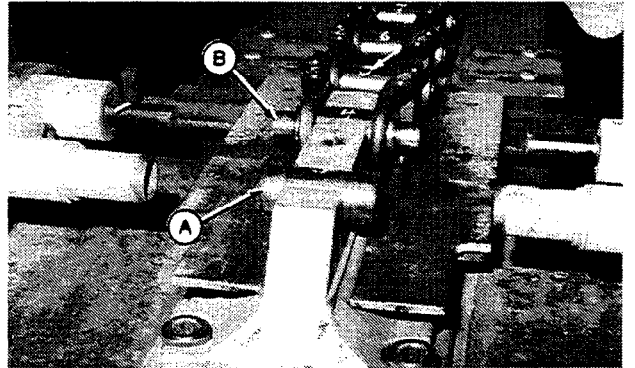

2AG;T93444 T47;0130 13 040285

16. Inspect track chain parts for cracks or wear; replace if necessary. Use a wire brush to remove any rust or dirt on machined surfaces.



2AG;T93445 T47;0130 14 220783

ASSEMBLE TRACK CHAIN

1. Assemble one link assembly to check for proper track press head shimming. It may be necessary, depending on link wear, to vary the number of adjusting shims behind the assembly adapter plates to insure correct bushing stickout dimension of 7.44 mm (0.298 in).

Use a gauge plate from track press tooling kit during this shim adjustment procedure and periodically during chain assembly.

2. When the track shoes are completely removed, place track gauge plate (A) along with pilot plugs, washers, and tapped pilot plugs (B), assembled to the right holes of track gauge plate and to right side track link.

Operate ram assembly until a hand plug can be inserted through holes in the gauge plate and left side track link.

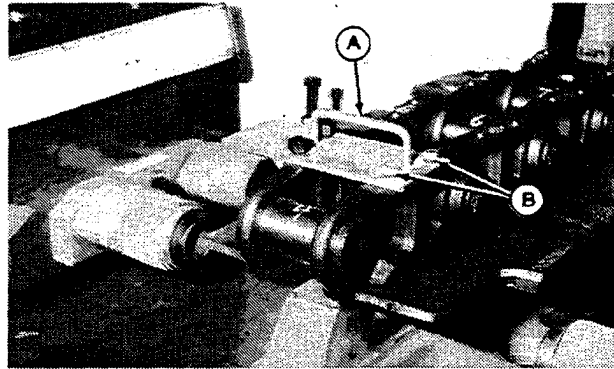

2AG:T94580 T47:0130 6033DP 040285

Track Systems

3. On a new track, dimension "C₁" equals "C₂". Considerable wear is often encountered on the bushing face of the side link, in which case dimension "C₁" will be greater than "C₂". To correct for this wear, sleeve shims (3) are inserted between the plate and the bushing sleeve as shown to make "C₂" equal to "C₁". This assures that the link will be assembled squarely on the pin and the bolt holes will line up properly.

The bushing plunger is designed to retract into the bottom in the bushing sleeve to permit the bushing to protrude the correct distance "B₁" and "B₂" from the bushing face of the side link. Used bushings that are being turned may be worn on the ends and when the track is assembled, "B₁" may be greater than "B₂" or vice versa, depending on which link requires the greatest force to install. To correct this condition, plunger shims (2) (1/2 the thickness of the difference between "B₁" and "B₂") should be inserted behind both plungers.

In a like manner, used pins may be badly worn on the ends. If desired, the pins may be centered in the assembled track in the same manner by inserting pin plunger shims (1) (1/2 the thickness of the difference between "A₁" and "A₂".)

NOTE: Part numbers shown are from 26815 Tooling Set.

- | | |
|--|--|
| 1—(26116) Pin Plunger Shim (as required) | 2—(26332) Bushing Plunger Shim (as required) |
| | 3—(33016) Sleeve Shim (as required) |

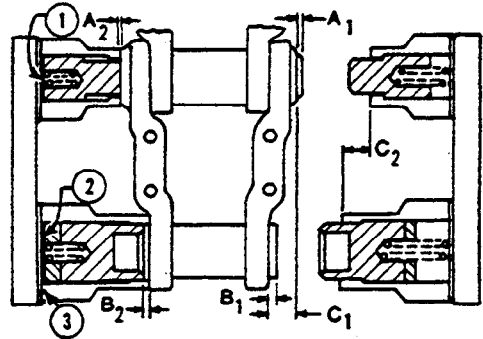

2AG:T92795 T47:0130 6033DQ 040285

Track Systems

NOTE: Part numbers shown are from 26815 Tooling Set.

- | | |
|---------------------------------------|--|
| A—(40989) Saddle | M—(10611) Pin (8 used) |
| B—(24288) R.H. Assembly Adapter Plate | N—(30350) Forcing Sleeve Bushing Side (2 used) |
| C—(10201) Nut (2 used) | O—(26545) Plunger, Bushing Side (2 used) |
| D—(10246) Washer (2 used) | P—(26330) Spacer (2 used) |
| E—(20529) Pilot Plug (2 used) | Q—(10372) Spring (2 used) |
| F—(28577) Track Gauge Plate | R—(26322) Shim (as required) |
| G—(20533) Hand Plug | S—(26788) Spacer (2 used) |
| H—(30140) Forcing Sleeve Pin (2 used) | T—33016 Shim (as required) |
| I—(30512) Plunger, Pin Side (2 used) | U—(33305) L.H. Assembly Adapter Plate |
| J—(20457) Shim (2 used) | V—(12916) Cap Screw (8 used) |
| K—(10370) Spring (2 used) | |
| L—(26116) Shim (as required) | |

Track Assembly Tooling

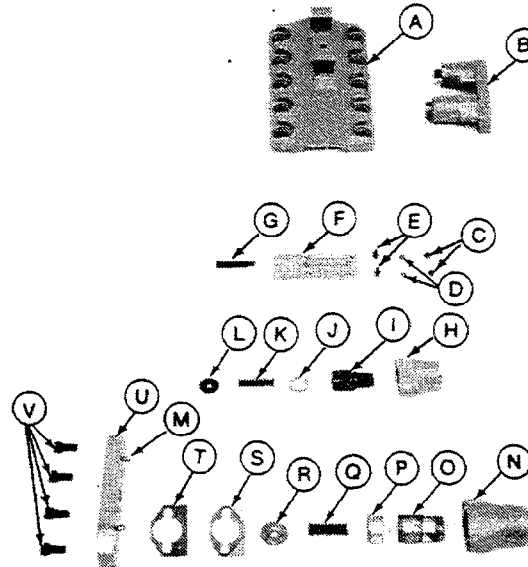

2AG:T6031AM T47;0130 6033DR 040285

4. Install saddle (A) in track press frame and secure with cap screws (B). (Same saddle used for disassembly).

5. Install assembly heads (C) from track press tooling set and secure with attaching nuts.

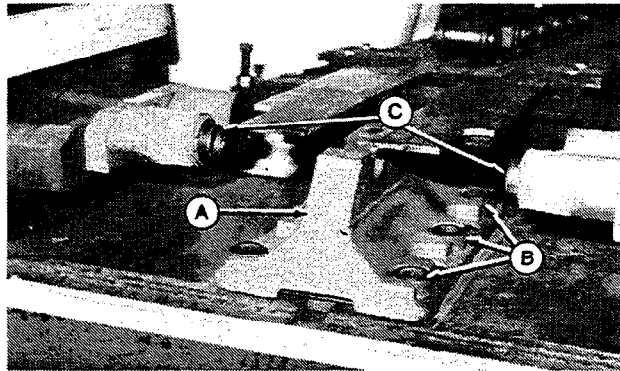

2AG:T94581 T47;0130 60330S 040285

NOTE: When assembling right and left hand track link to the master bushing, insert the master bushing spacer (A) into the right and left bushing plungers. (Spacer shown with Track Disassembly Tooling).

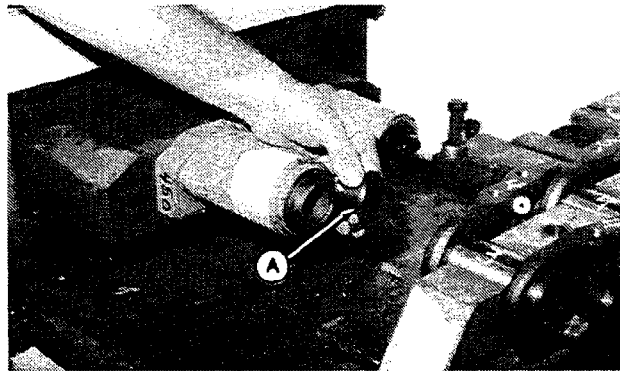

2AG:T94582 T47;0130 6033DT 040285

Track Systems

6. Lubricate pin with SAE 80W-90 gear oil.

T47:0130 20 220783

7. Install pin (A) in bushing and bushing (B) in saddle slot. Install two belleville seals (C) on each side of track pin. (See cross sectional drawing on Track Chain Link Connection). Install belleville seals with dished side opposite or outward. Place right and left track links (D) in position on assembly heads.

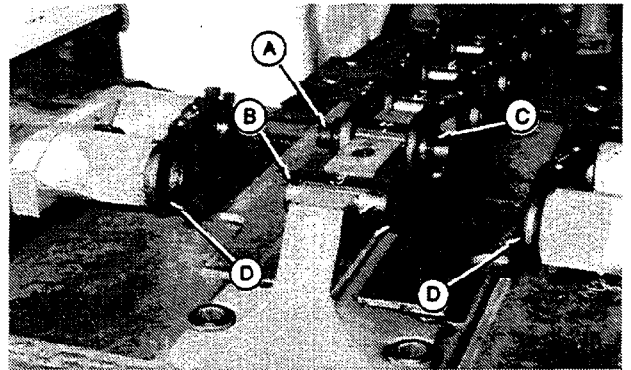

A—Track Pin
B—Track Bushing

C—Belleville Seals
D—Track Links

2AG:T94583 T47:0130 21 220783

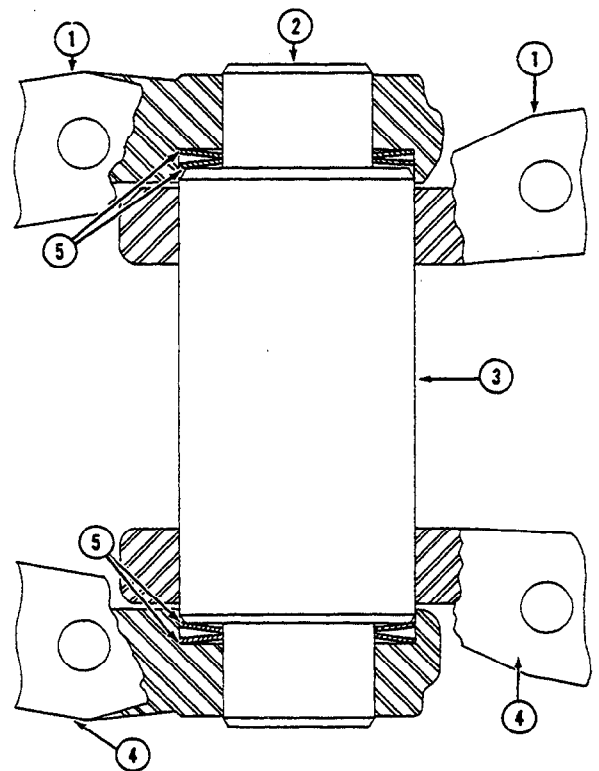

1—Left Track Link
2—Track Pin
3—Track Bushing

4—Right Track Link
5—Belleville Seals (4 used)

2AG:T43174 T47:0130 22 220783

Track Systems

8. Extend the left assembly head until the link almost contacts the track press saddle.

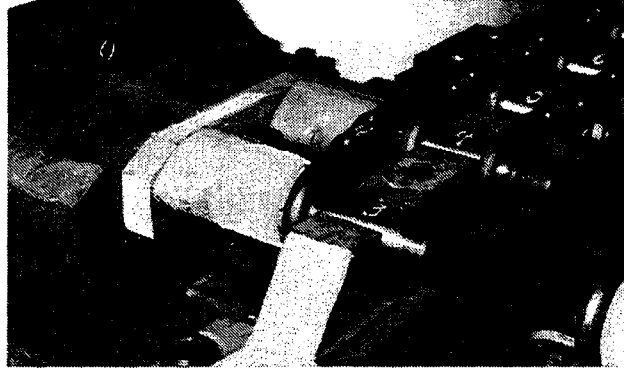

2AG;T94584 T47;0130 23 220783

9. Extend the right assembly head until the bushing contacts the link seats. Bushing and pin should be centered in saddle during assembly. Continue pressing until the track shoe bolt holes are in alignment with gauge from track press tooling set.

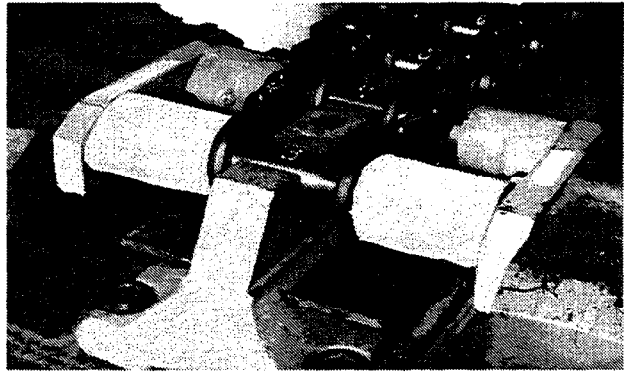

2AG;T94585 T47;0130 6033DU 040285

10. Raise conveyor and slide chain away from operator. Position newly installed bushing in rear saddle slot.

T47;0130 25 040285

Track Systems

11. Assemble remainder of chain using the previous steps.

NOTE: Master pin (2) is installed when assembling track to crawler unit. Two special spacers (4) make up the dimensional differences in the master bushing (5) when installing master pin (2). (See beginning of this group for breaking track chain procedure.)

- | | |
|--------------------------------|-------------------------------------|
| 1—Right Track Link | 4—Master Bushing Spacer
(2 used) |
| 2—Master Pin | 5—Master Bushing |
| 3—Belleville Seals
(4 used) | 6—Left Track Link |

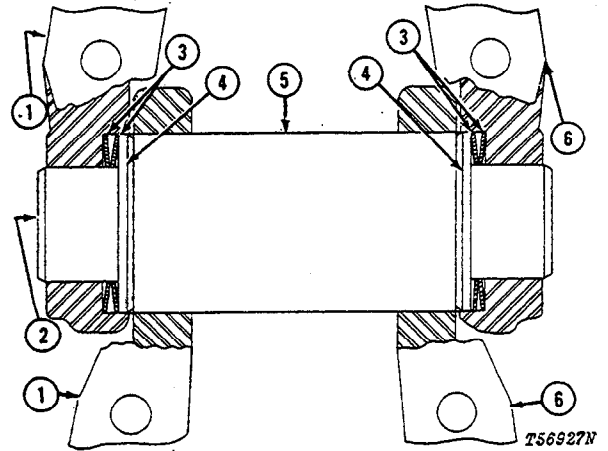

2AG;T56927 T47;0130 26 220783

REMOVE AND INSPECT TRACK SHOES

1. Remove bolts and nuts securing track shoe to link. Hold nut in position with a large screwdriver while loosening bolt.
2. Remove shoe.
3. Inspect shoes for excessive grouser wear, cracks or broken shoes.

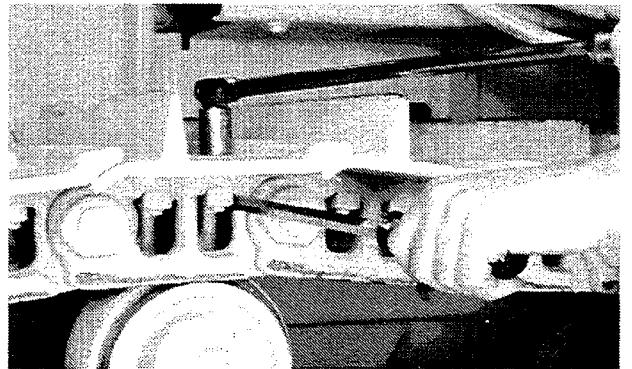

2AG;T6023AL T47;0130 6033DV 040285

INSTALL TRACK SHOES

1. Install track shoes. Track shoe mounting surfaces must be clean and free of paint. Apply oil to bolt threads and bearing surface of head. Install nuts with rounded edges (A) against the link and chamfered edges (B) away from the link. Tighten bolts to 163 N·m (120 lb-ft).

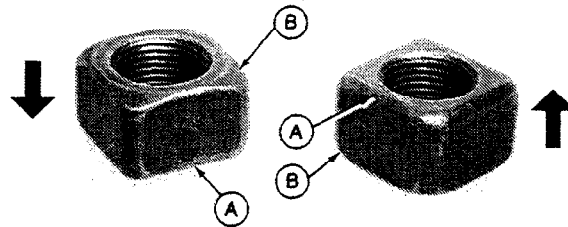
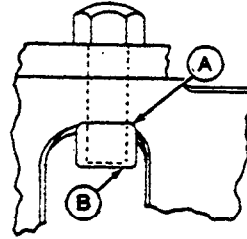

2AG;T96291, T96292 T47;0130 6033DW 040285

REMOVE DRIVE SPROCKET

1. Remove nine cap screws and washers and lift sprocket from axle shaft.

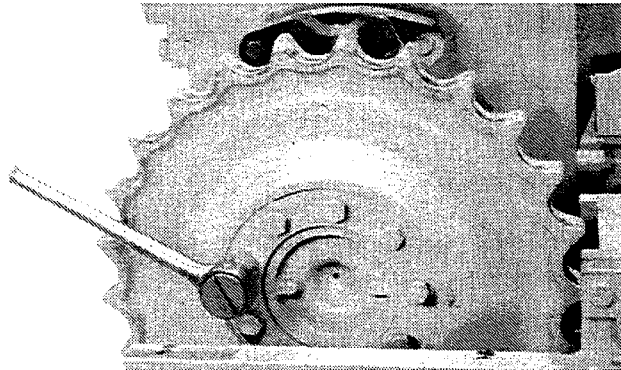

2AG;T93560 T47;0130 6033DX 040285

REMOVE TRACK FRAME

1. Remove two cap screws and washers to remove retainer (A) and shims (B).

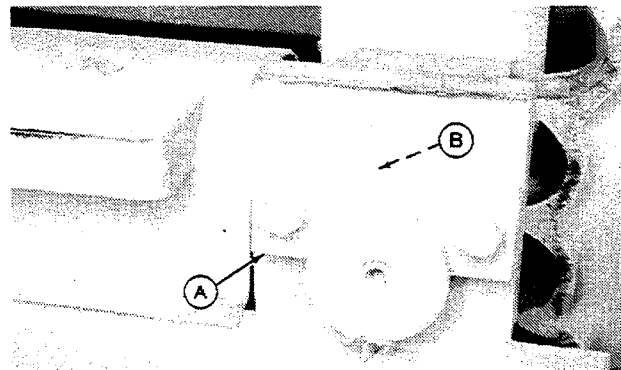

2AG;T6025AJ T47;0130 6033DY 040285

Track Systems

2. On wide track units, remove two cap screws (A) and washers to remove retainer (C) and shim (D).

3. Remove two cap screws (E), washers (F), and shaft key (H) to remove locking collar (G) from frame and rear crossbar (I).

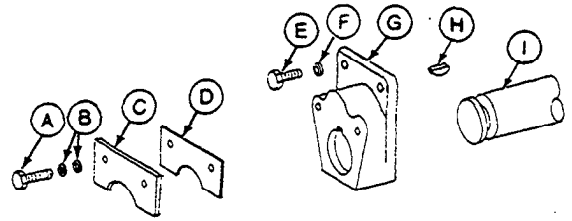

A—Cap Screw (2 used)	F—Washer (2 used)
B—Washer (2 used)	G—Locking Collar
C—Retainer	H—Shaft Key
D—Shim	I—Rear Crossbar
E—Cap Screw (2 used)	

2AG;T6037AI T47;0130 6033DZ 040285

4. Attach hoist.

5. Remove six cap screws and flat washers from front crossbar.

6. Move front idler (A) forward.

7. Pull track frame assembly free from rear crossbar (B) and slide clear of crossbar.

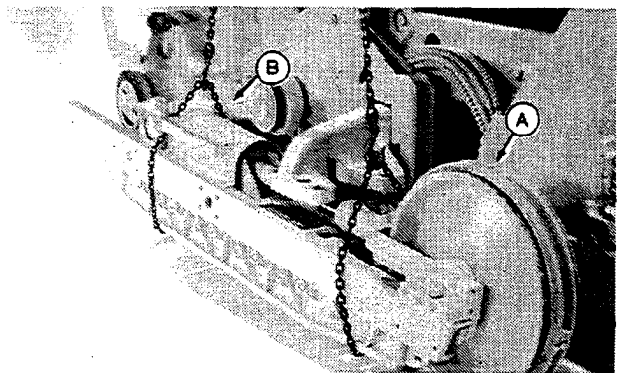
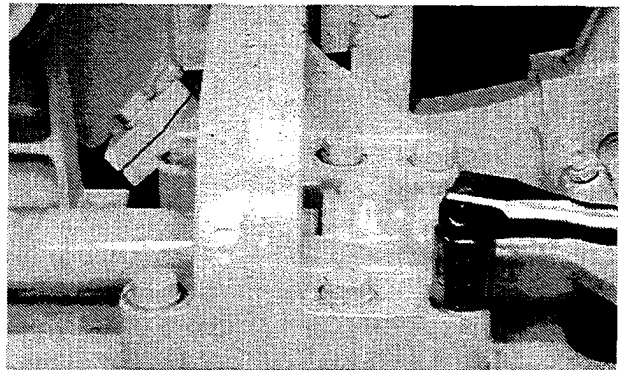

2AG;T93562,T93563 T47;0130 6034DA 040285

REMOVE UPPER CARRIER ROLLER ASSEMBLY

1. Remove four cap screws and lock washers (A) to remove track carrier roller support assembly.

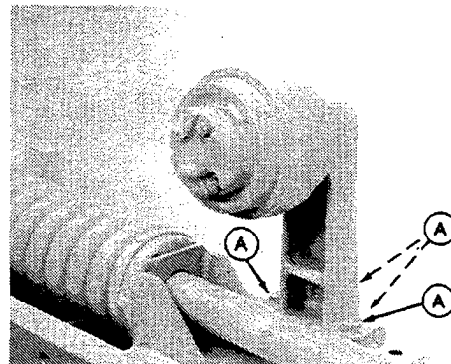

2AG;T93564 T47;0130 39 220783

DISASSEMBLE AND INSPECT UPPER CARRIER ROLLER ASSEMBLY

1. Remove three cap screws and lock washers to remove cover (A) and gasket.

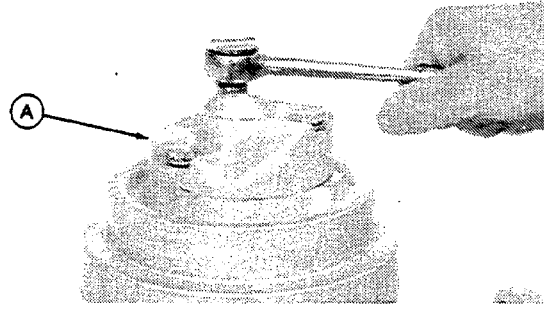

2AG;T93565 T47;0130 40 220783

2. Remove two socket head cap screws to remove plate (A) and roller assembly (B).

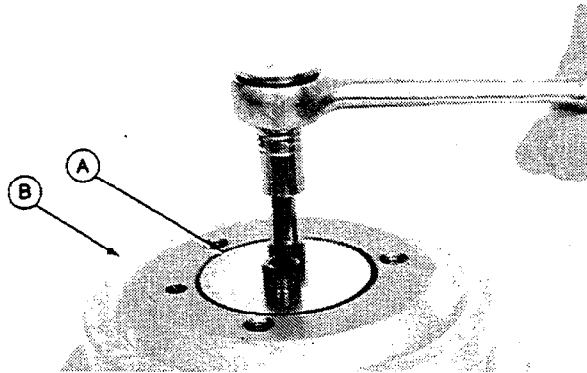

2AG;T93566 T47;0130 41 220783

3. Remove oil seal in carrier support.

NOTE: Keep metal face of seals lubricated and together at all times while disassembled.

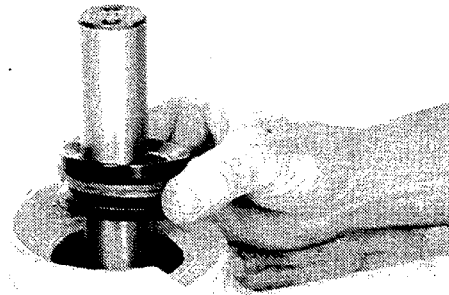

2AG;T93567 T47;0130 42 220783

4. Inspect shaft for wear or damage, replace only if necessary. Remove shaft using a press and a piece of pipe with 101.6 mm (4 in.) O.D. and a minimum length of 50.8 mm (2 in.).

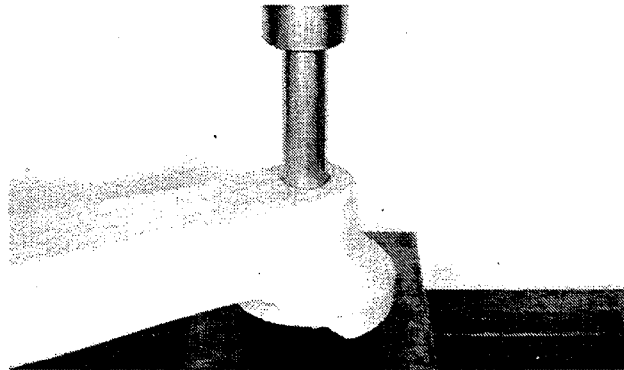

2AG;T93568 T47;0130 43 220783

ASSEMBLE UPPER CARRIER ROLLER

1. If replacement of the two bushings in roller is necessary, use 35 mm and 39 mm disks from driver set.

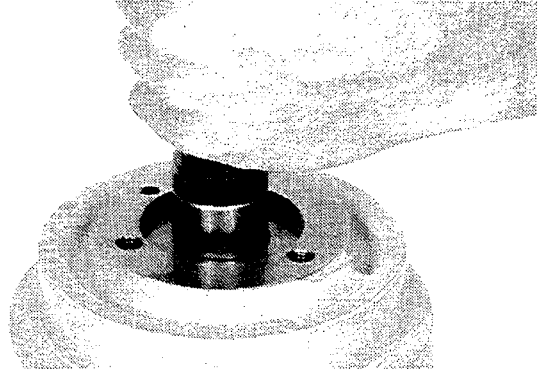

2AG;T93569 T47;0130 6034DB 040285

2. Install new shaft using a press. Press in shaft to 145.03 to 145.54 mm (5.710 to 5.730 in.) above the face of seal bore.

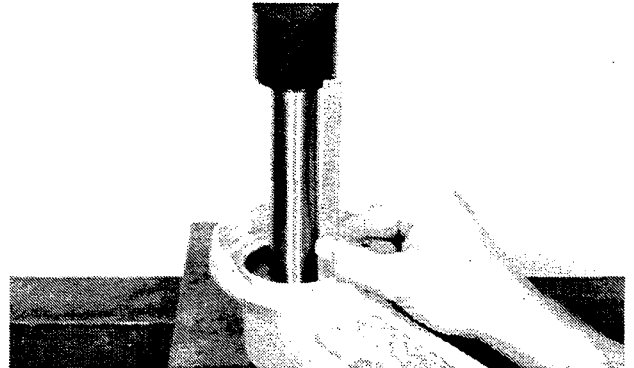

2AG;T93570 T47;0130 45 220783

IMPORTANT: The metal face seal bore in support and roller must be degreased with clean solvent and dried before installing seal.

3. Install oil seal into support. Side with the retainer ring goes into support. It is recommended that a new oil seal kit be installed.

IMPORTANT: DO NOT remove plastic retaining ring from new seal.

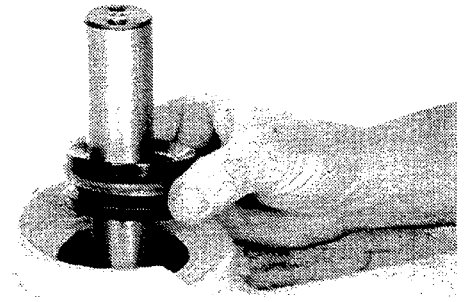

2AG;T93567 T47;0130 46 040285

4. Install roller assembly (A), plate (B) and two socket head screws. Tighten screws to 54 ± 3 N·m (40 ± 3 lb-ft).

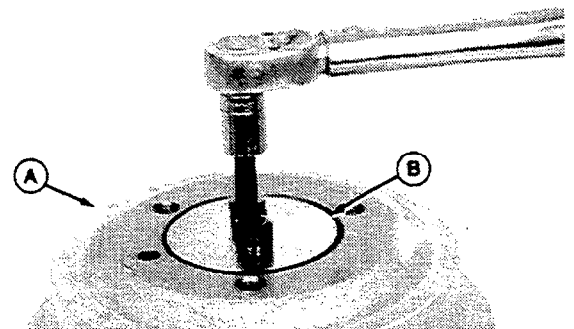

2AG;T93571 T47;0130 6034DC 040285

Track Systems

5. Install washer and gasket on the longer cap screw (A).

6. Install cover with three cap screws. Tighten cap screw (A) to 41 ± 4 N·m (30 ± 3 lb-ft) and cap screws (B) to 47 N·m (35 lb-ft).

7. Fill roller assembly with approximately 710 mL (1-1/2 pint) of the recommended oil. (See Lubrication in Section I.)

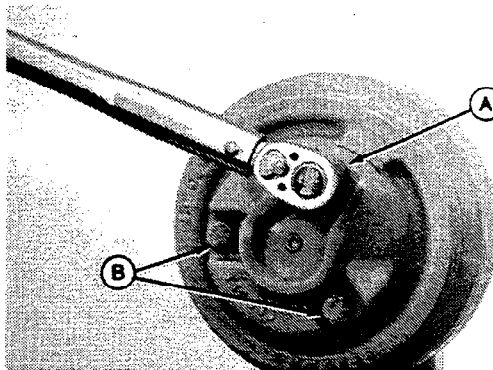

2AG:T94007 T47:0130 6034DD 040285

REMOVE FRONT IDLER ASSEMBLY

1. Remove two cap screws and lock washers (A) from both sides.

2. Attach hoist and slide front idler forward off track frame.

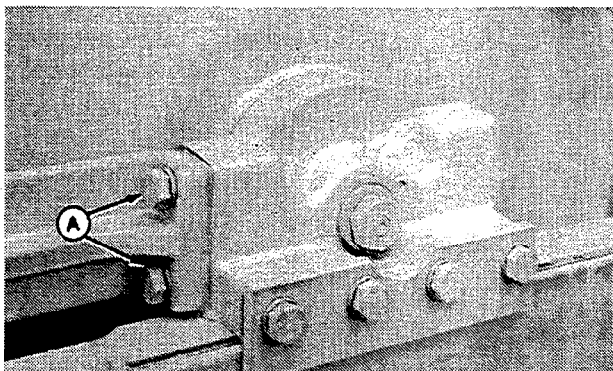

2AG:T93572 T47:0130 48 220783

DISASSEMBLE AND INSPECT FRONT IDLER ASSEMBLY

1. Remove two cap screws and lock washers (F) on bottom of both sides to remove shims (E) and wear strap (D). Remove four cap screws and lock washers (A) on both sides to remove guide (B) and shims (C).

A—Cap Screw (8 used)

B—Guide (2 used)

C—Shims

D—Wear Strap (2 used)

E—Shims

F—Cap Screw (4 used)

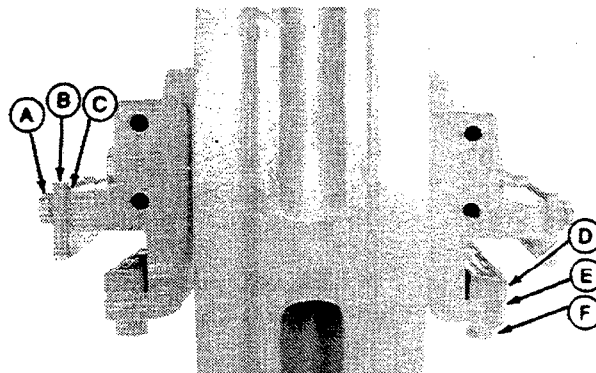

2AG:T93573 T47:0130 49 220783

2. Remove cap screw, washer and O-ring to remove bracket (A) on each side.

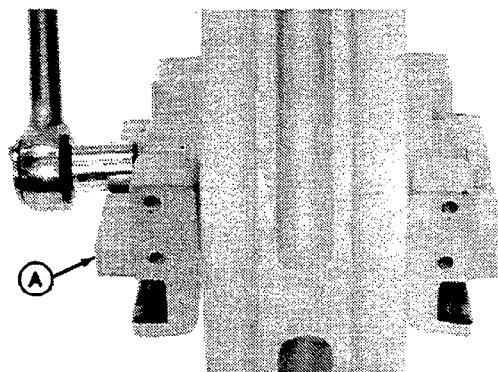

2AG:T93574 T47:0130 50 040285

IMPORTANT: Keep metal face of seals lubricated and together at all times while disassembled.

3. Remove six socket head screw to remove seal ring (A) and seals (B) on each side.

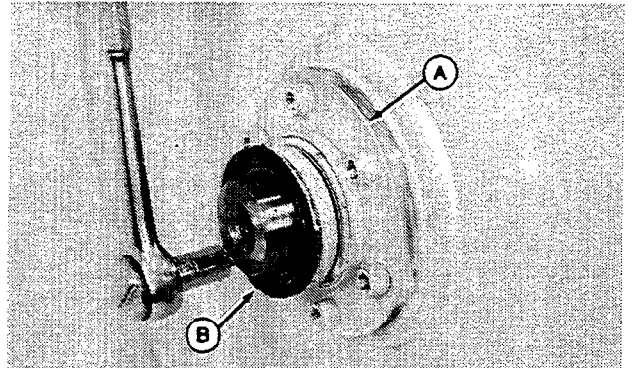

2AG;T93575 T47:0130 51 220783

4. Remove plate (A) and gasket (B) on each side.

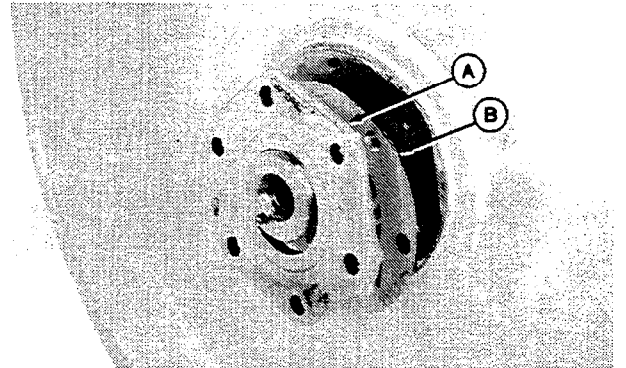

2AG;T93576 T47:0130 52 220783

5. Remove shaft (A) and inspect bushings (B) for wear or damage; replace if necessary.

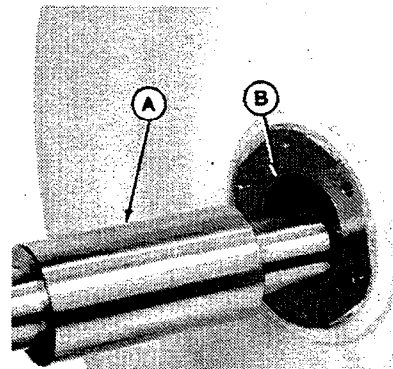

2AG;T93577 T47:0130 53 220783

ASSEMBLE FRONT IDLER ASSEMBLY

1. Clean all parts thoroughly.
2. Install new bushing using 66 mm and 71 mm disks from driver set. Install bushing 0.79 mm (0.031 in.) below face of roller.

NOTE: Replacement idler bushings are pre-sized and, therefore, do not need to be sized after installation.

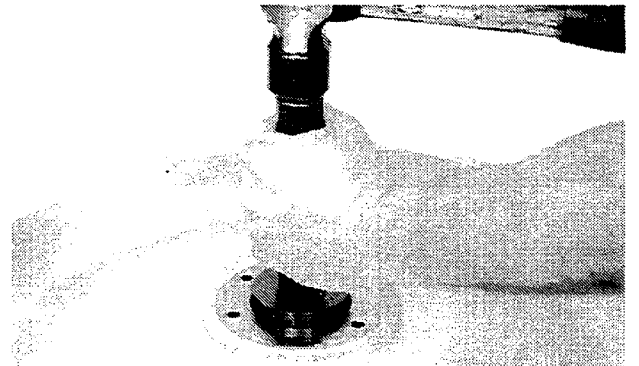

2AG;T93578 T47:0130 6034DE 040285

IMPORTANT: Lubricate idler bushing (B) with oil before installing shaft.

2. Install shaft (A).

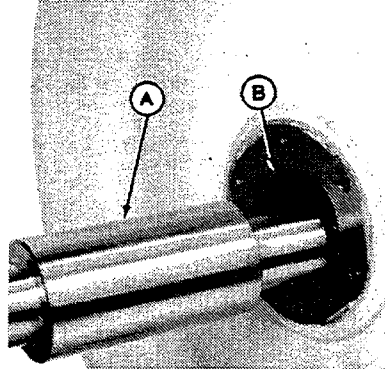

2AG;T93577 T47;0130 55 220783

3. Install new gasket (B) and thrust plate (A), chamfered edge of plate facing toward inside of front idler.

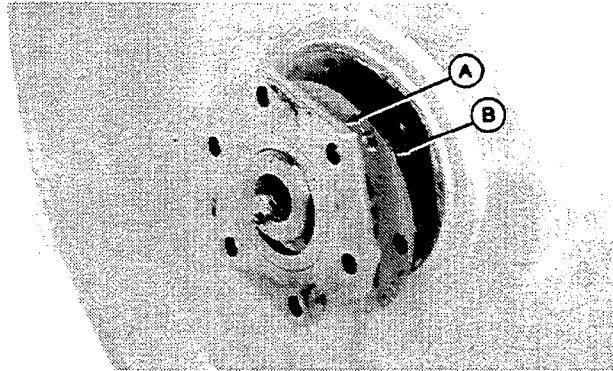

2AG;T93576 T47;0130 56 060983

4. Install seal ring (B).

5. Install three socket head cap screws and finger tighten to position thrust plate, gasket, and seal ring.

6. Center seal ring on shaft using a JT30018 Seal Centering Fixture (A).

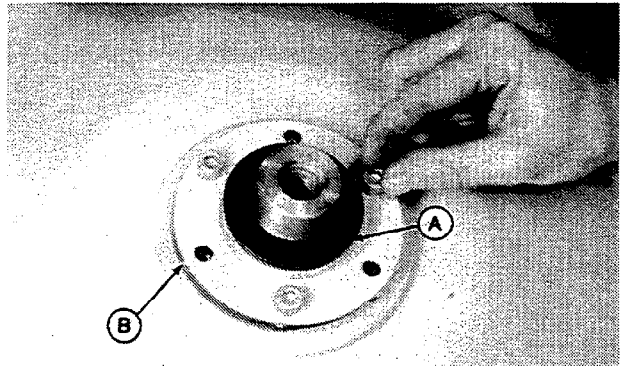

2AG;T6044AK T47;0130 6044JA 040285

Track Systems

7. Install the other three cap screws and tighten them all.

8. Remove seal centering fixture.

NOTE: *DO NOT* remove plastic retaining ring from new seal.

9. Install new oil seal (A). Side with retainer goes into seal ring. Seal must be straight in bore. It is recommended that a new oil seal kit be installed.

10. Tighten six cap screws to 68 ± 7 N·m (50 ± 5 lb-ft). Repeat steps 4—10 on other side.

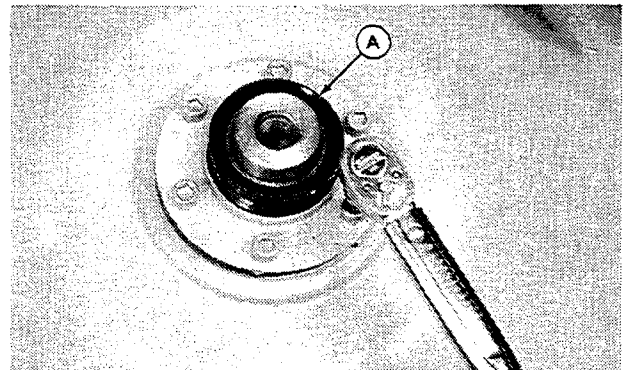
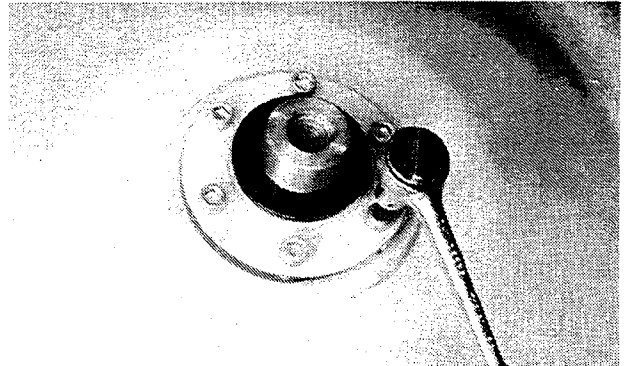

2AG;T6044AJ, T6044AJ T47;0130 6044JB 040285

11. Install outer bracket, one with pipe plug, on shaft end with pin. Install inner bracket on opposite side. Secure with washer, cap screw and new O-ring. Apply thread lock and sealer (medium strength) to second through tenth thread of screw. Tighten inner bracket cap screw to 407 ± 41 N·m (300 ± 30 lb-ft).

Tighten outer bracket special cap screw with Part No. on head to 407 ± 41 N·m (300 ± 30 lb-ft) or the special cap screw with no marking on head to 285 N·m (210 ± 21 lb-ft).

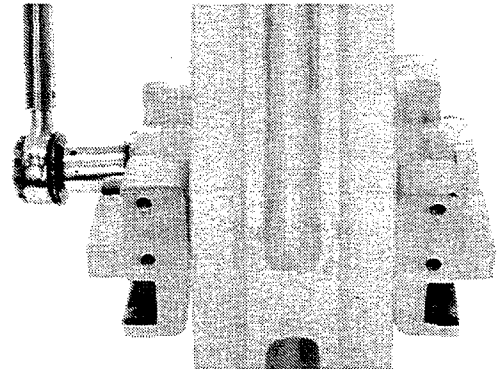

2AG;T93580 T47;0130 6034DG 040285

12. Install shims (A) guide (B) and four cap screws and lock washers on each side. Tighten to 115 ± 11 N·m (85 ± 8 lb-ft).

13. Assemble wear plate (C) to bracket on each side using same shims (D) as removed. Leave the two cap screws and washers loose until later.

A—Shims
B—Guide (2 used)

C—Wear Plate (2 used)
D—Shims

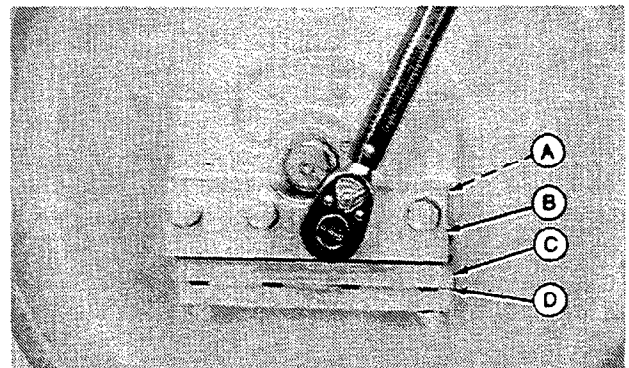

2AG;T93581 T47;0130 59 040285

REMOVE HYDRAULIC TRACK TENSION ADJUSTER

1. Pull hydraulic track tension adjuster assembly forward to free from track idler recoil spring.

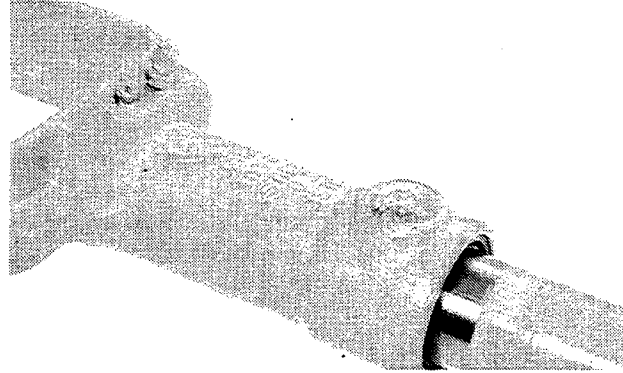

2AG;T93582 T47;0130 60 040285

DISASSEMBLE AND INSPECT HYDRAULIC TRACK TENSION ADJUSTER

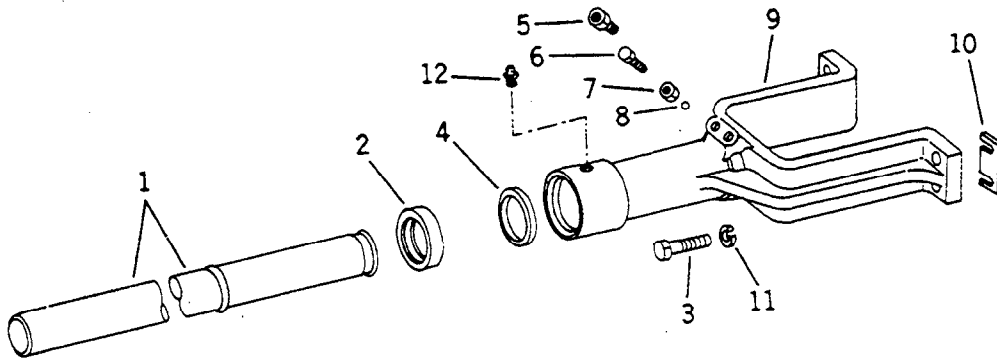

1—Piston
2—Piston Seal
3—Cap Screw (4 used)

4—Scraper Seal
5—Grease Fitting
6—Set Screw

7—Nut
8—Ball
9—Yoke

10—Shim (6 used)
11—Lock Washer (4 used)
12—Grease Fitting



CAUTION: High pressure can be present in track adjusting cylinder. Do not visually inspect grease vent hole.

IMPORTANT: Do not pull piston from track adjusting yoke unless seal and piston seal are to be replaced or seals will be damaged.

1. Pull track adjusting piston (1) from yoke (9).
2. Remove and discard piston seal (2).
3. Remove and discard yoke scraper seal (4).
4. Inspect and clean all parts.
5. To aid disassembly, remove grease fitting (5) to prevent suction.

2AG;T94012 T47;0130 61 040285

ASSEMBLE HYDRAULIC TRACK TENSION ADJUSTER

NOTE: If grease has been removed from track adjusting yoke cylinder or if a new yoke cylinder is installed, bleed yoke cylinder as follows: (a) with cylinder release screw loosened, place a small amount of grease in bottom of cylinder, (b) move piston to bottom of bore without seating oil seal. A small amount of grease should be forced out the bleed hole. If necessary, add grease and repeat procedure until grease is observed at bleed hole.

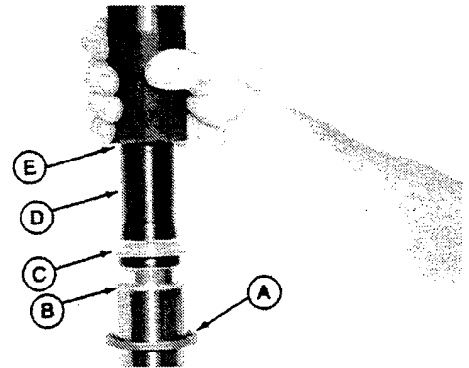

1. Install scraper seal (A) on piston, metal side up.
2. Set conical seal installation tool (D) from JD-284 Hydraulic Adjuster Service Kit on piston (B) and lubricate tool.
3. Insert piston seal (C), groove side up, on conical tool. Using seal installation driver (E), drive the piston seal onto recessed area of piston.

A—Scraper Seal	D—Conical Seal Installation Tool
B—Piston	E—Seal Installation Driver
C—Piston Seal	

2AG;T93583 T47;0130 62 040285

3. Insert approximately 2 tblspn of grease in cylinder and lubricate top 50 mm (2 in.) of cylinder wall.
4. Place piston seal installing guide (A) from JD-284 Hydraulic Adjuster Service Kit on piston seal. Tighten cap screws. Force piston in by hand until seal clears the flange. Remove piston guide.
5. Drive scraper seal (B) into recess of cylinder using driver (C).

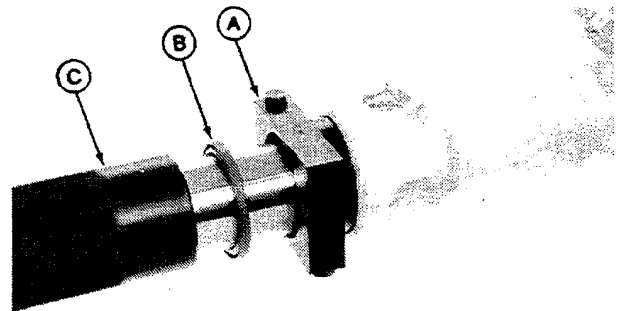

2AG;T93584 T47;0130 63 040285

REMOVE TRACK IDLER RECOIL SPRING

IMPORTANT: When sliding idler assembly forward, do not pull track adjusting piston from yoke as scraper seal may damage piston seal.

1. Slide front idler with hydraulic track tension adjuster assembly forward.
2. Remove four cap screws and washers to remove cover (A).

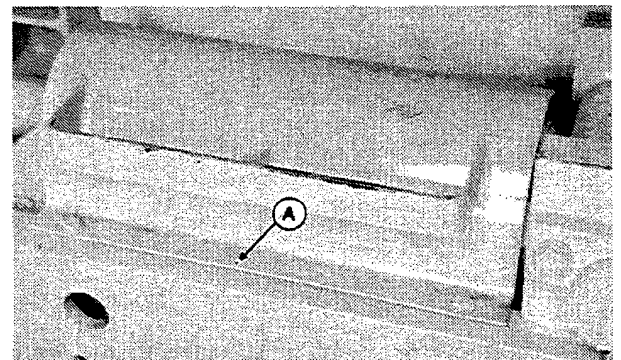

2AG;T6025AD T47;0130 6034DH 040285

3. Thoroughly clean threads of rear cap.



CAUTION: Always use the special bolt or a bolt similar in strength and fatigue life to prevent accidental release of idler recoil spring.

4. Insert a T16678 Special Bolt, threads sprayed with NEVER-SEEZ lubricant, and a 38.1 mm (1.5 in.) spacer through the track spring retainer plate and thread into rear cap. Tighten bolt until spring compresses to 403.23 mm (15-7/8 in.) between the outer end of front cap and rear cap. Lift spring from track frame.

5. Turn the T16678 Special Bolt counterclockwise to release spring tension. Remove bolt.

6. Inspect all parts.

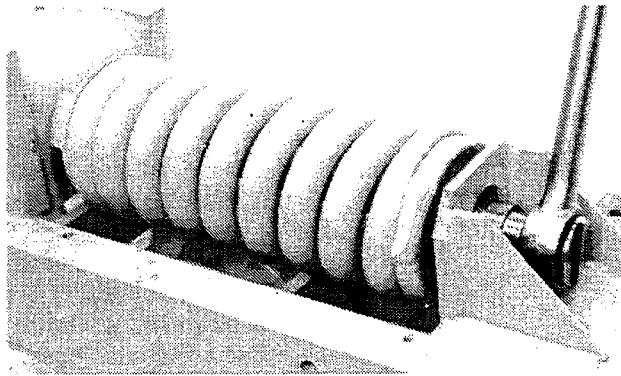

2AG:T93586 T47:0130 65 220783

REMOVE AND INSTALL ROCK GUARDS

1. Remove ten cap screws (F) and lock washers from outer rock guard (C) and inner rock guard (B).
2. Remove cap screw (E) and lock washer (D).
3. Remove five nuts (H), lock washers (I), spacers (J), and cap screws (A).
4. Remove inner and outer rock guards.
5. Install inner rock guard. Install and tighten ten cap screws (F) and lock washers to 230 N·m (170 lb-ft).
6. Install five cap screws (A) through inner rock guard and install spacers (J) on screws.
7. Install outer rock guard. Install and tighten ten cap screws (F) and lock washers to 230 N·m 9170 lb-ft).
8. Install lock washers (I) and nuts (H) on five spacer cap screws. Tighten nuts to 163 ± 16 N·m (120 ± 12 lb-ft).
9. Install and tighten cap screws (E) and lock washer.

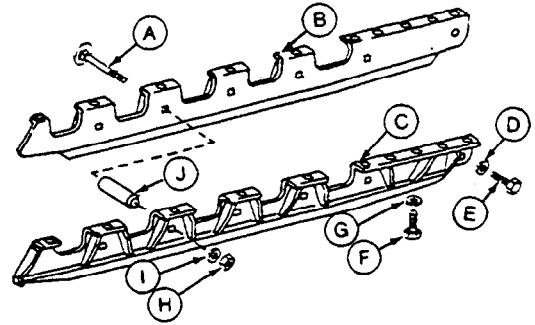

A—Cap Screw (5 used)	F—Cap Screw (20 used)
B—Inner Rock Guard	G—Lock Washer (20 used)
C—Outer Rock Guard	H—Nut
D—Lock Washer	I—Lock Washer (5 used)
E—Cap Screw	J—Spacer (5 used)

REMOVE AND INSTALL CHAIN GUIDES

1. Remove twelve cap screws (G) and lock washers (F).
2. Remove two nuts (H) to remove lock washers (F), spacers (D), and cap screws (B).
3. Remove chain guides.
4. Install inner chain guides (A and C). Install and tighten six cap screws (G) and lock washers (F).
5. Install two cap screws (B) through inner chain guide and install spacers (D) on screws.
6. Install outer chain guides (E and I). Install and tighten six cap screws (G) and lock washers (F).
7. Install and tighten lock washers and nuts (H) on spacer cap screws.

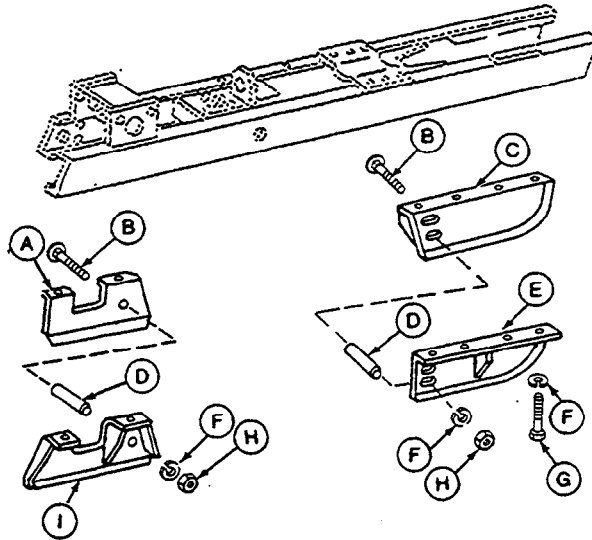

- | | |
|---------------------------|---------------------------|
| A—Rear Inner Chain Guide | E—Front Outer Chain Guide |
| B—Cap Screw (2 used) | F—Lock Washer (14 used) |
| C—Front Inner Chain Guide | G—Cap Screw (12 used) |
| D—Spacer (2 used) | H—Nut (2 used) |
| | I—Rear Outer Chain Guide |

2AG;T6033CC T47;0130 6034DJ 040285

REMOVE TRACK ROLLERS

NOTE: Track rollers can be removed without disconnecting track. Release track tension to provide sufficient slack.

1. If unit is equipped with rock guards, remove outer rock guard and loosen inner rock guard cap screws. (See Remove and Install Rock Guards in this group.)
2. If unit is equipped with chain guides, remove rear chain guide. (See Remove and Install Chain Guide in this group.)
3. Raise crawler with a jack or hoist to provide a clearance for roller removal. Block securely.
4. Remove four cap screws (A) and lock washers on each roller bracket and remove roller assembly.

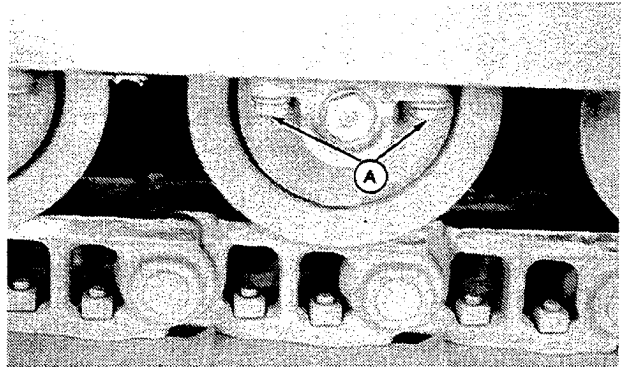

2AG;T6014AD T47;0130 6034DK 040285

DISASSEMBLE TRACK ROLLER

1. Remove two cap screws, washers, and o-rings to remove roller brackets (A).

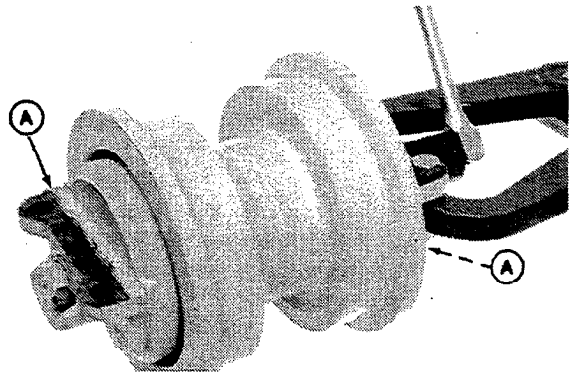

2AG;T93589 T47;0130 68 220783

2. Remove six socket head cap screws to remove seal ring (A) and oil seal (B) on each side.

NOTE: Keep metal face of seals lubricated and together at all times while disassembled.

3. Remove thrust plate (C) gasket (D) and shaft.
4. Examine all parts for wear or damage. Replace all parts as required.

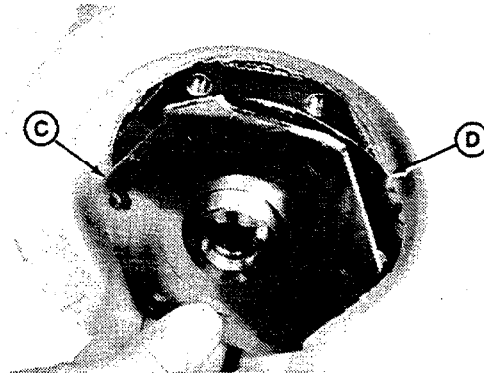
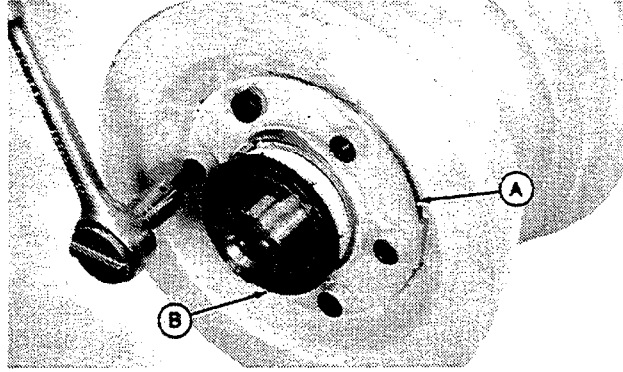

A—Seal Ring
B—Oil Seal

C—Thrust Plate
D—Gasket

2AG;T93590,T93591 T47;0130 69 220783

ASSEMBLE TRACK ROLLERS

NOTE: Replacement roller bushings are pre-sized and therefore do not need to be sized after installation.

1. The I.D. of the roller bushing is 60.41 to 60.44 mm. (2.3785 to 2.3795 in.). If necessary to replace bushings, use 60 mm and 63 mm disks from driver set. Install new bushings 0.79 mm (0.031 in.) below face of roller with open ends of oil grooves to the inside.

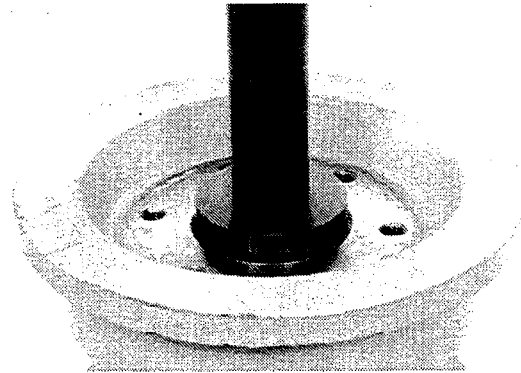

2AG;T93592 T47;0130 6034DL 040285

Track Systems

2. Lubricate bushings (B) with oil and install shaft (A).

3. Install gasket (D) and thrust plate (C), chamfered edge facing toward outside of track rollers.

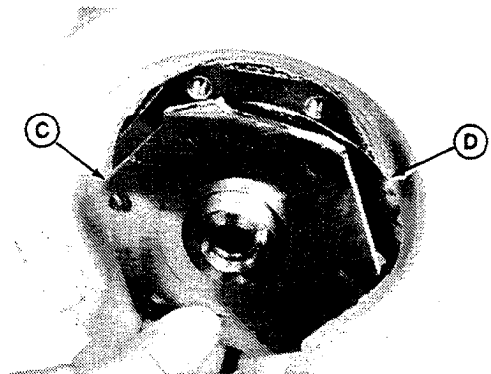
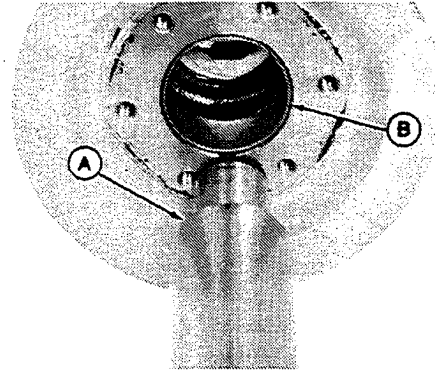

A—Shaft
B—Bushing (2 used)

C—Thrust Plate
D—Gasket

2AG;T93593,T93591 T47;0130 71 040285

4. Install seal ring (A).

5. Install three socket head cap screws (C) alternately spaced and finger tighten to position thrust plates, gasket, and seal ring.

6. Center seal ring on shaft using a JT30019 Seal Centering Fixture (B).

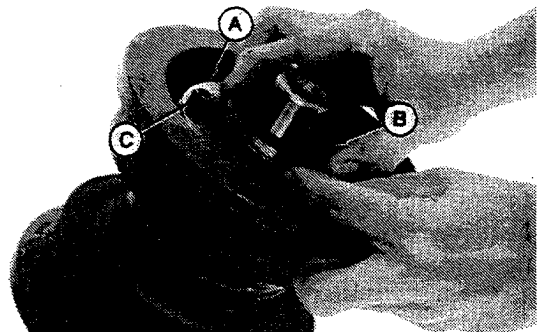

2AG;T6044AH T47;0130 6044JC 020485

7. Install the other three cap screws and tighten them all.
8. Remove seal centering fixture.

NOTE: DO NOT remove plastic retaining ring from new seal.

9. It is recommended that a new oil seal kit be installed. Install new oil seal (A). Side with retainer ring goes into seal ring. Seal must be straight in bore.

10. Tighten six cap screws to 68 ± 7 N·m (50 ± 5 lb-ft). Repeat steps 4—10 on the other side.

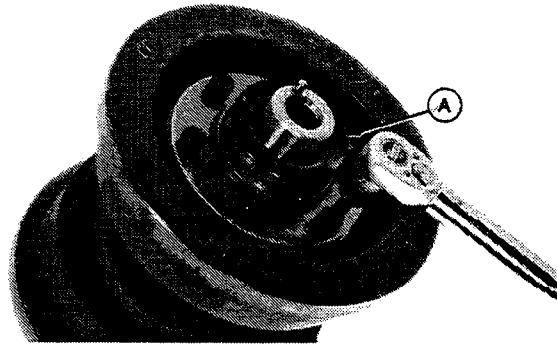
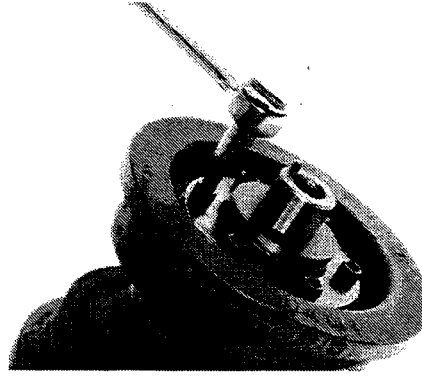

2AG;T6044AA, T6044AC T47;0130 6044JD 040285

11. Degrease sealing surface of roller bracket.
12. Install roller bracket, that does not have plugs, on the shaft end not having the pin. Install O-ring, washer, and cap screw. Tighten finger tight.
13. Install roller bracket, having the plugs, on shaft end having the pin. Install O-ring, washer and special cap screw. Tighten finger tight.
14. Tighten inside bracket cap screw to 407 ± 41 N·m (300 ± 30 lb-ft).
15. Tighten outer bracket special cap screw with Part No. on head to $407 \pm$ N·m (300 ± 30 lb-ft) or the special cap screw with No. marking on head to 285 N·m (210 ± 21 lb-ft).
16. Fill assembly with approximately 178 ml (3/8 pt) of the recommended oil. (See Lubrication in Section I).

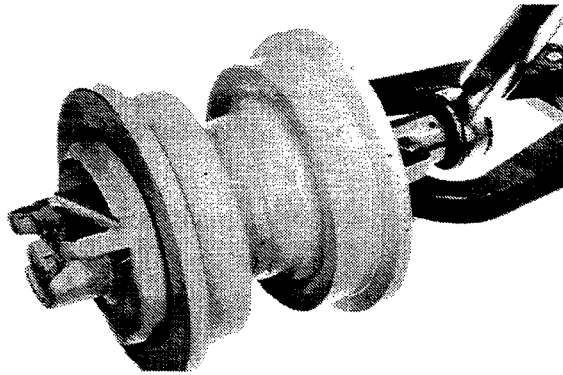

2AG;T93595 T47;0130 6044JE 040285

INSPECT AND REPAIR TRACK FRAME

1. Inspect channel wear strips (A and B). If worn, remove old wear strips and weld on new strips. Use 5/32 in. diameter low carbon AWS-ASTM E-7018 covered electrode.

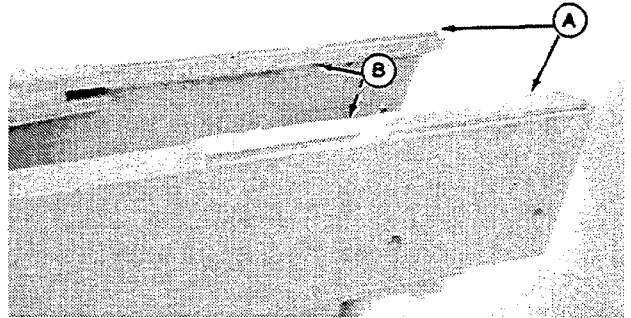

2AG;T93596 T47;0130 74 220783

INSTALL TRACK ROLLERS

1. Position roller in track frame with special screw facing outward. Install four cap screws (A) and lock washers. Tighten cap screws to 175 ± 18 N·m (130 ± 13 lb-ft).

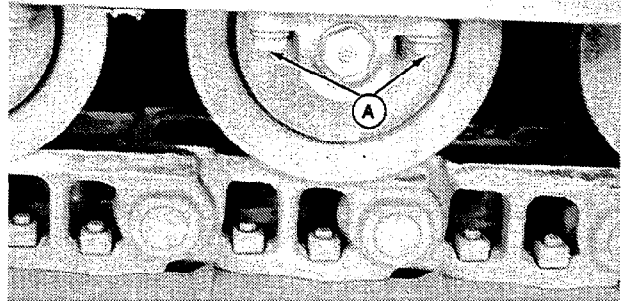

2AG;T6014AD T47;0130 6034DN 040285

2. Install rock guards (if equipped). (See Remove and Install Rock Guards in this group.)

3. Install chain guides (if equipped). (See Remove and Install Chain Guides in this group.)

T47;0130 6034DO 040285

INSTALL IDLER RECOIL SPRING

1. Position preload spring assembly between spring retaining plate and rear mounting pad.

2. Remove T16678 Special Bolt and 38.1 mm (1.5 in.) spacer. Be sure spring is firmly fixed in place.

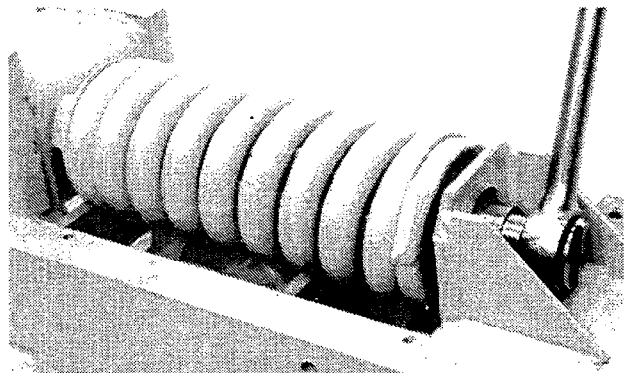

2AG;T93586 T48;0130 77 220783

3. Attach cover (A) with four cap screws and lock washers.

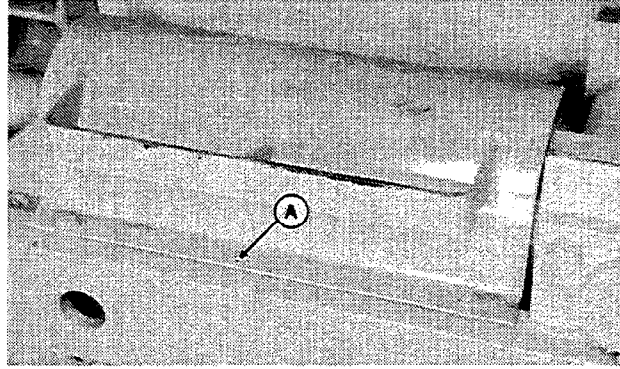

2AG;T6025AD T47;0130 6035DI 040285

INSTALL HYDRAULIC TRACK TENSION ADJUSTER

1. Position hydraulic track tension adjuster piston into track recoil spring. Attach yoke to front idler. (See Install Front Idler Assembly in this group.)

T47;0130 79 220783

INSTALL FRONT IDLER ASSEMBLY

1. With a hoist, slide front idler assembly into position on track carrier assembly.

T47;0130 80 220783

2. Connect track adjusting cylinder yoke to idler brackets using original shim pack. Tighten four cap screws and lock washers to 115 ± 11 N·m (85 ± 8 lb-ft).

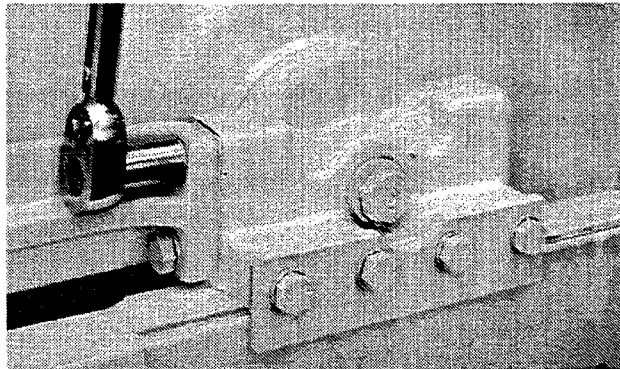

2AG;T93599 T47;0130 81 220783

INSTALL TRACK FRAME

1. Slide track frame on rear cross bar (B).
2. Slide front idler (A) rearward.
3. Install six cap screws and flat washers on front crossbar. Tighten cap screws to 576 ± 54 N·m (425 ± 40 lb-ft).

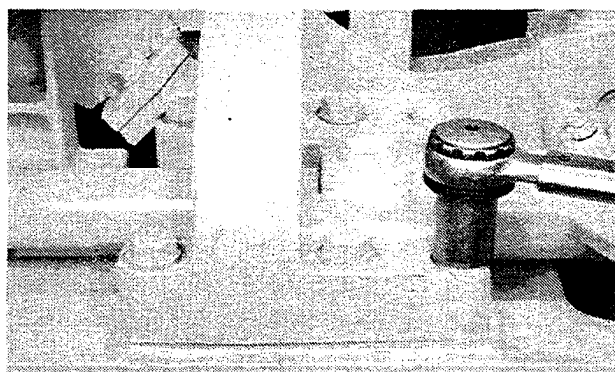
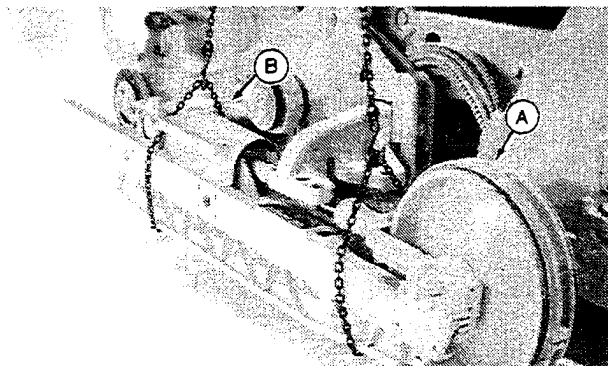

2AG;T93563,T93600 T47;0130 82 220783

INSTALL DRIVE SPROCKET

1. Clean sprocket and axle shaft mounting surface.
2. Install drive sprocket.
3. Install nine washers and cap screws. Tighten cap screws to 576 ± 57 N·m (425 ± 42 lb-ft).

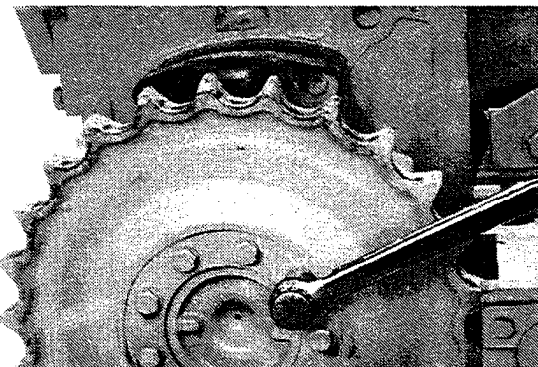

2AG;T6033BZ T47;0130 6034DQ 040285

4. Shift track frame in or out until drive sprocket is centered between flanges of rear roller (A).
5. Install enough shims (B) to fill space between retainer (C) and rear cross bar.

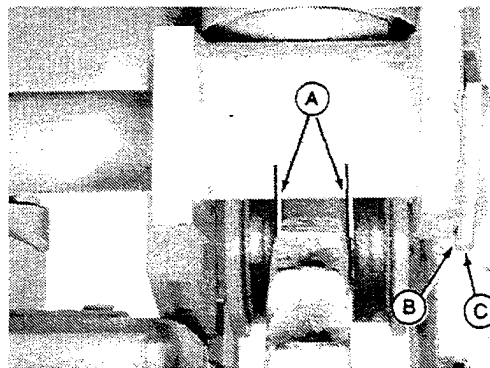

2AG;T93602 T47;0130 84 220783

7. Install shims (B), two cap screws and lock washers in retainer (A) to frame. Tighten cap screws to 231 ± 23 N·m (170 ± 17 lb-ft).

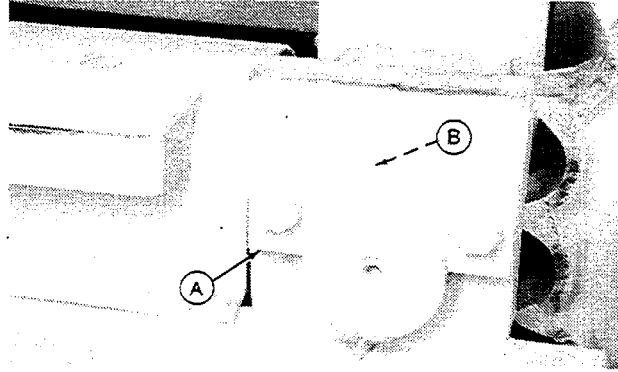

2AG;T6025AI T47;0130 6034DR 040285

8. On wide track units, install locking collar (G) and shaft key (H). Install and tighten cap screws (E) and washers to 909 ± 95 N·m (670 ± 70 lb-ft).

9. Install shim (D) and retainer (C).

10. Install and tighten two cap screws (A) and washers to 230 ± 23 N·m (170 ± 17 lb-ft).

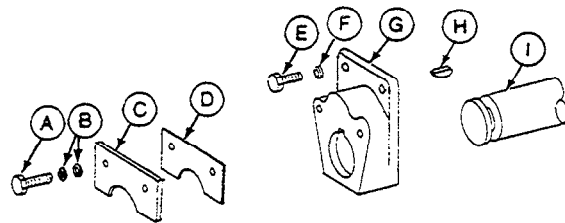

- | | |
|----------------------|----------------------|
| A—Cap Screw (2 used) | E—Cap Screw (2 used) |
| B—Washer (4 used) | F—Washer (2 used) |
| C—Retainer | G—Locking Collar |
| D—Shim | H—Key |
| | I—Crossbar |

INSTALL UPPER CARRIER ROLLER ASSEMBLY

1. Install carrier roller assembly support with four cap screws and lock washers (A). Tighten to 115 ± 11 N·m (85 ± 8 lb-ft).

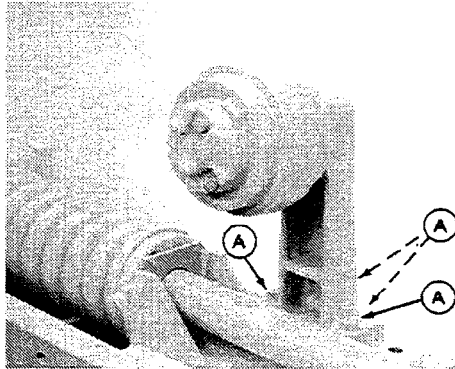

2AG;T8657A93564;018701694B5 040285

INSTALL TRACK CHAIN

1. Position track assembly on unit.

2. Install seals (A) with disked side opposite or outward in left and right link counterbore. Install spacer (B) with flat side toward seals.

NOTE: When installing a new master pin, it is recommended that the complete master pin kit be installed. The kit contains a master pin, two spacers and four seals.

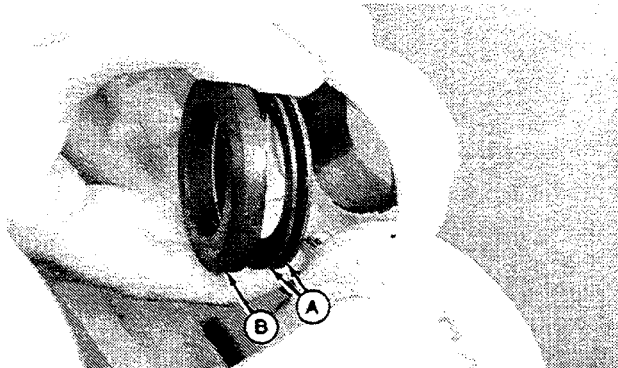

2AG;T93558 T47;0130 88 220783

Track Systems

3. Connect the track links and install forcing pin (B) into track links.

4. Install master pin (A) into master pin pusher. Install aligning adapter (C) and secure with holding screw (D).

5. Position "C" frame around forcing pin (B) and tighten ram adjusting screw.

6. Use the hydraulic hand pump to replace the forcing pin with the master pin.

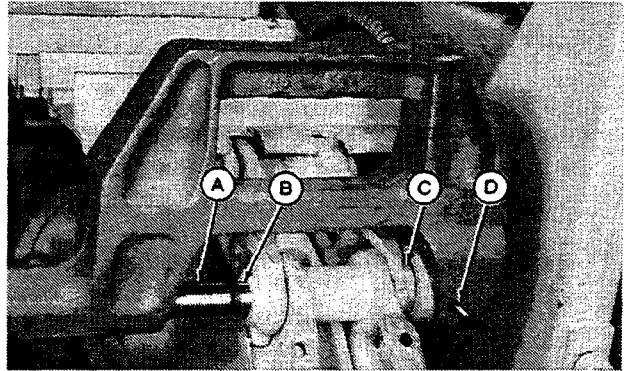

A—Master Pin
B—Forcing Pin

C—Aligning Adapter
D—Holding Screw

2AG;T93605 T47;0130 6034DT 040285

CHECK TRACK SAG

1. Position track so that a track pin (A) is centered over the carrier roller (B).

2. Measure sag in center of track between carrier roller and front idler (C). Correct sag is 22—28.5 mm (7/8—1-1/8 in.). If adjustment is needed, see Adjust Track Sag.

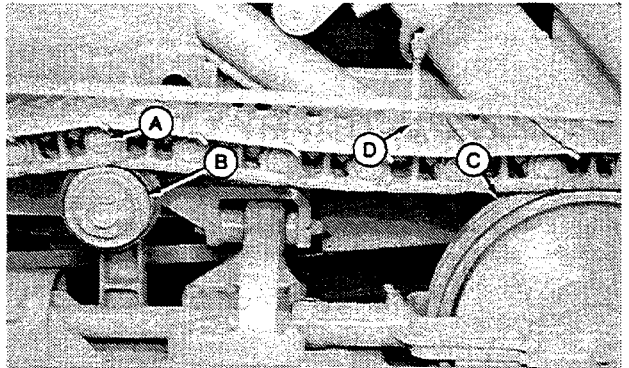

2AG;T91532 T47;0130 6034DU 040285

ADJUST TRACK SAG

CAUTION: When you work near the track adjuster or recoil spring, **USE EXTREME CARE. DO NOT** disassemble parts unless you know the correct procedure and have correct tools.

IMPORTANT: The adjustment cylinder has an adjustment fitting on the yoke end and a lubrication fitting on the barrel end. **DO NOT** use the grease fitting on the yoke end for lubrication. Use this fitting **ONLY** for track adjustment. After adjustment has been made, you must apply grease to the lubrication fitting on the barrel end.

1. Connect a grease gun (maximum capacity 55 200 kPa [8000 psi]) to the grease fitting on the yoke end of the cylinder (as shown). Add grease until the track is tight. Check for kinked links.
2. Drive crawler forward and backward several times to straighten any kinked links.
3. Mark on track frame the location of the front idler bracket.

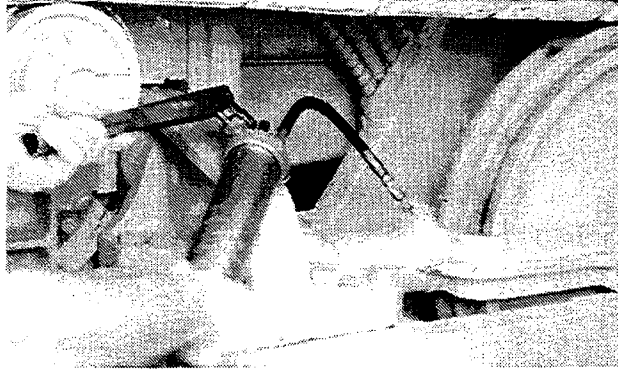

2AG;T90694, T6008AW T47;0130 6034DV 040285

CAUTION: The track adjuster cylinder may have high pressure. If grease does not immediately come out of the vent hole (A), drive the crawler forward and backward slowly.

4. Turn set screw one to three turns counterclockwise to release grease until the distance between the mark on the track frame and the idler bracket is 3—5 mm (1/8—3/16 in.). Tighten set screw.

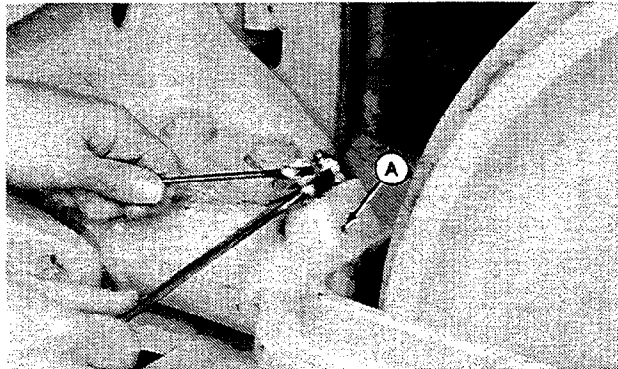

2AG;T90695 T47;0130 6035NI 040285

IMPORTANT: Each time track is adjusted, apply grease to the lubrication fitting on the barrel end of the adjuster until grease escapes past the scraper seal at the end of the barrel.

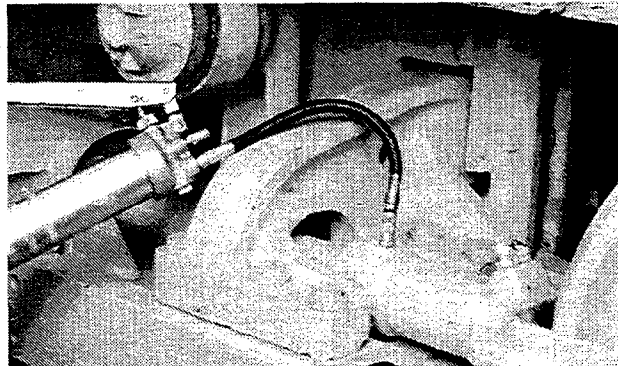

2AG;T90697 T47;0130 6034DW 040285

ALIGN TRACK

1. Check track alignment by driving forward on level ground for about 7.62 m (25 ft). Stop crawler without touching steering levers.

2. Examine location of track link in relation to front idler flanges. If clearance is not equal on both sides (A), the tracks are not properly aligned.

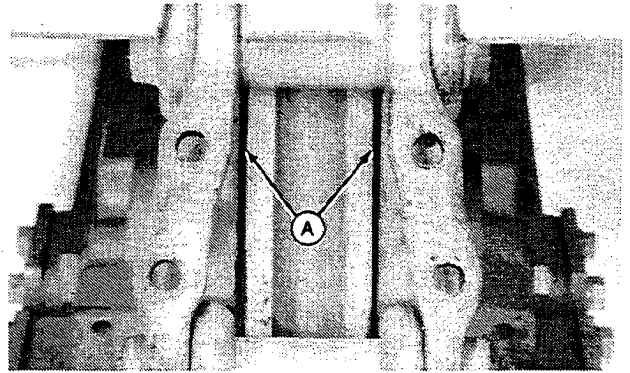

2AG;T92246 T47;0130 91 040285

3. To adjust, remove one shim (A) at a time from the rear of the track idler bracket on the side having the least clearance. Test by running the crawler in a straight line. Proceed to remove shims until idler is centered between track links.

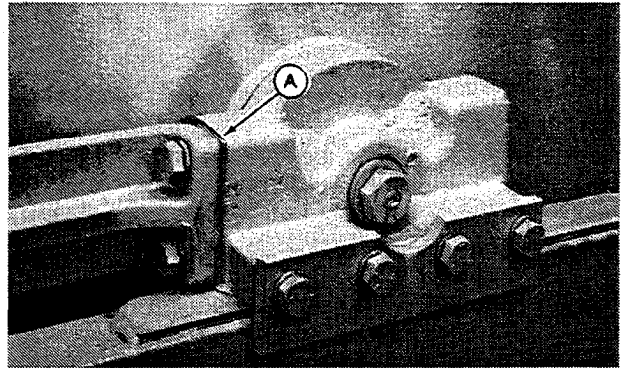

2AG;T93657 T47;0130 92 250783

4. Install the two track shoes and tighten cap screws to 163 N·m (120 lb-ft).

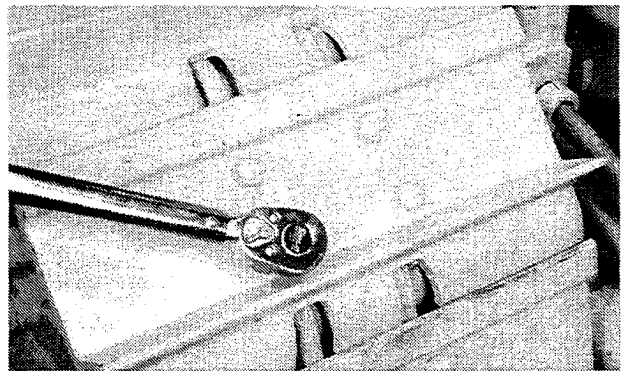

2AG;T93606 T47;0130 6034DX 040285

CHECK FRONT IDLER HORIZONTAL ADJUSTMENT

NOTE: This adjustment insures that the side loads are carried equally by both guides. Front idler must slide freely on the track frame.

NOTE: Track chain removed for clarity of photograph.

1. Force the idler assembly inward until the inner bracket just contacts the track frame at point (A). The outer guide should now contact the track frame at point (B). If contact is not being made at both locations at the same time, add or subtract shims at point (B). Tighten the four guide cap screws to 115 ± 11 N·m (85 ± 8 lb-ft).

2. Force the idler assembly outward. The inner guide should contact the track frame at point (C) and the outer guide should contact the track frame at point (D). If contact is not being made at both locations at the same time, add or subtract shims at point (D). Tighten the four cap screws to 115 ± 11 N·m (85 ± 8 lb-ft).

3. Make sure idler is centered between the track.

A—Point A
B—Point B

C—Point C
D—Point D

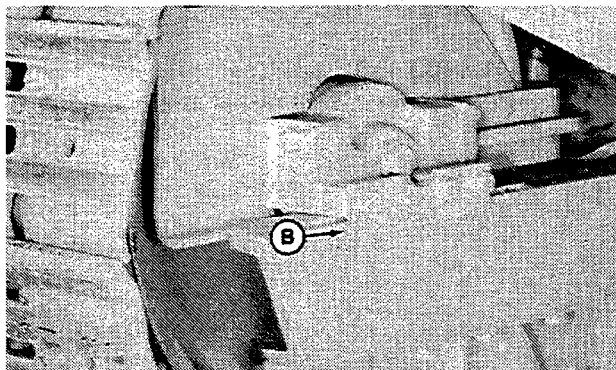
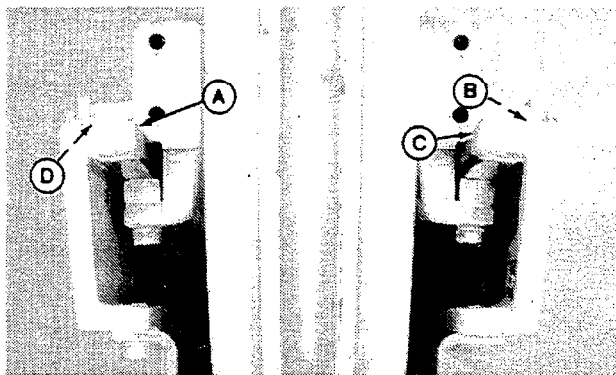

2AG;T93607,T93608 T47;0130 94 250783

CHECK FRONT IDLER VERTICAL MOVEMENT

NOTE: Make certain the front idler horizontal adjustment using parts (A—C) is correct before making this adjustment.

1. Drive machine onto wood block. Make sure block is under front idler.

NOTE: Shim pack added should fill gap but still allow front idler to slide freely on track frame.

2. Use feeler gauge to measure gap between idler bracket and track frame. The allowable clearance is 0.00 to 1.0 mm (0.000 to 0.040 in.). If gap is more than 1.0 mm (0.040 in.) remove front idler assembly. Remove two cap screws and lock washers (F). Add sufficient shims (E), or replace wear strap (D) to meet allowable clearance specifications.

- | | |
|----------------------|-----------------------|
| A—Cap Screw (8 used) | D—Wear Strap (2 used) |
| B—Guide (2 used) | E—Shims |
| C—Shims | F—Cap Screw (4 used) |

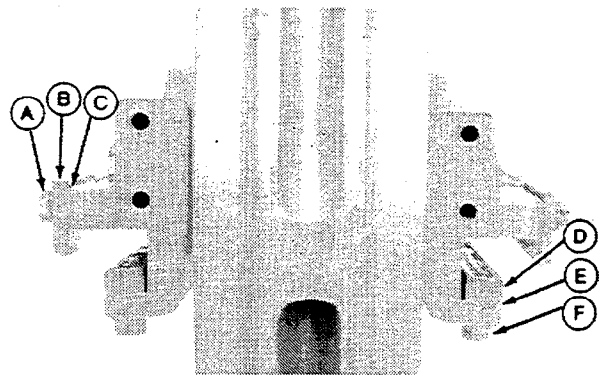
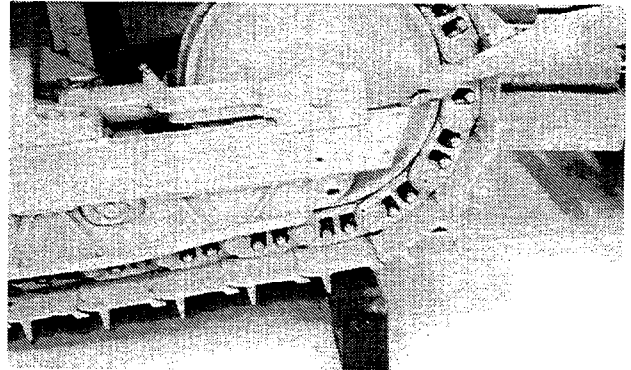

2AG;T90696, T93573 T47;0130 95 250783

3. Install front idler assembly and re-check vertical movement.

4. Install track if vertical movement is correct.

T47;0130 96 250783

MEASURE LINK HEIGHT

Measure link height to then nearest 0.5 mm (0.020 in.) using a depth gauge from undercarriage inspection service tool kit. Put the depth gauge on outside of track link against pin boss as shown. Measure several links to the nearest 0.5 mm (0.020 in.).

LINK HEIGHT SPECIFICATION

Link height of a new chain	90 mm (3.54 in.)
Maximum recommended link height	82.8 mm (3.26 in.)

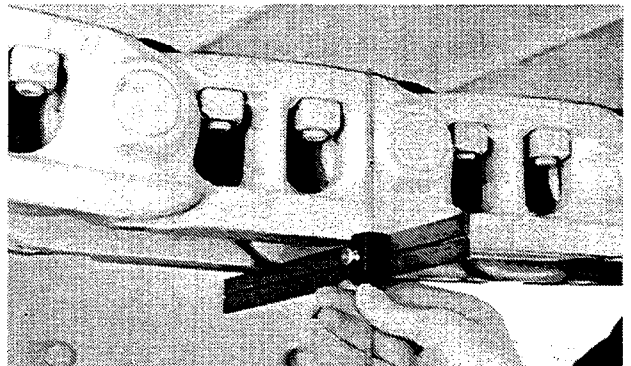

2AG;T5802AD T47;0130 6034DY 040285

MEASURE TRACK BUSHING OUTER DIAMETER

Measure reverse drive side wear (A) and forward drive side wear (B) of the bushing using a caliper and scale from undercarriage inspection tool kit. Position the caliper so that as it is passed back and forth over the bushing, one tip will slide parallel along the worn surface. Close caliper until the opposite tip just touches the unworn side of the bushing. Measure several bushing to the nearest 0.020 in. (0.5 mm).

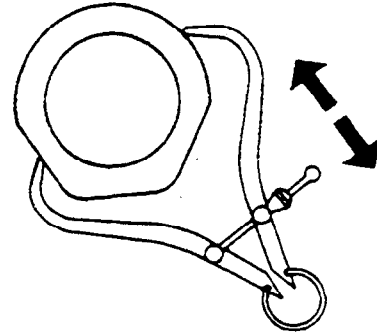
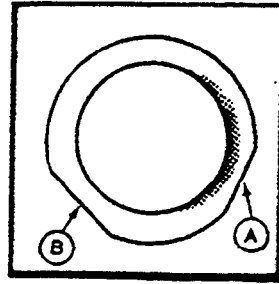

BUSHING OUTSIDE DIAMETER SPECIFICATION

Outside diameter of a new bushing	51.0 mm (2.01 in.)
Minimum recommended bushing outside diameter (normal loading)	46.0 mm (1.81 in.)
Minimum recommended bushing outside diameter (high shock loading)	48.0 mm (1.89 in.)

2AG;T6033CD T47;0130 60340Z 040285

MEASURE TRACK PITCH

1. Place a pin or block between sprocket and chain. Move unit in reverse until chain is tight.

2. Measure track pitch using a tape measure. Measure a straight section of chain, such as between carrier roller and idler. Measure from the left edge of one track pin to the left edge of fifth track pin. This measurement covers wear in four pin and bushing joints.

3. Record measurement to the nearest 0.020 in. (0.5 mm) and repeat for several sections. Do not measure across the master pin joint.

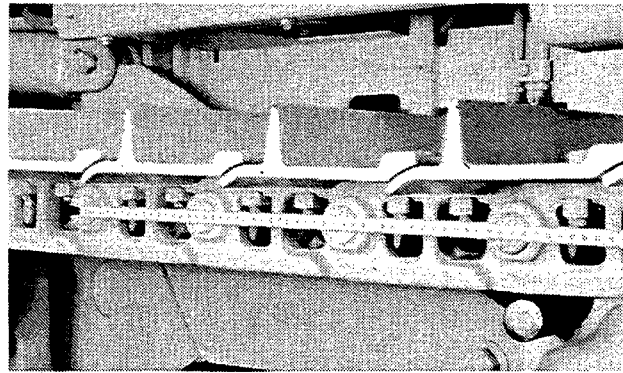

TRACK PITCH MEASUREMENT SPECIFICATION

Distance across four pins of new chain	640.1 mm (25.2 in.)
Maximum recommended distance across four pins	652.8 mm (25.7 in.)

2AG;T93611 T47;0130 6035DA 040285

MEASURE GROUSER BAR HEIGHT

1. Clean grouser and track shoe plate surface to be measure.
2. Measure grouser bar height using a depth gauge from undercarriage inspection service tool kit. Repeat measurement to nearest 0.020 in. (0.5 mm) for several grousers and record the average.

TRACK SHOE WEAR SPECIFICATION

Full grouser height	48.0 mm (1.89 in.)
Minimum recommended full grouser height	20.0 mm (0.79 in.)
Full semi-grouser height	21.1 mm (0.83 in.)
Minimum recommended semi-grouser height	12.0 mm (0.47 in.)

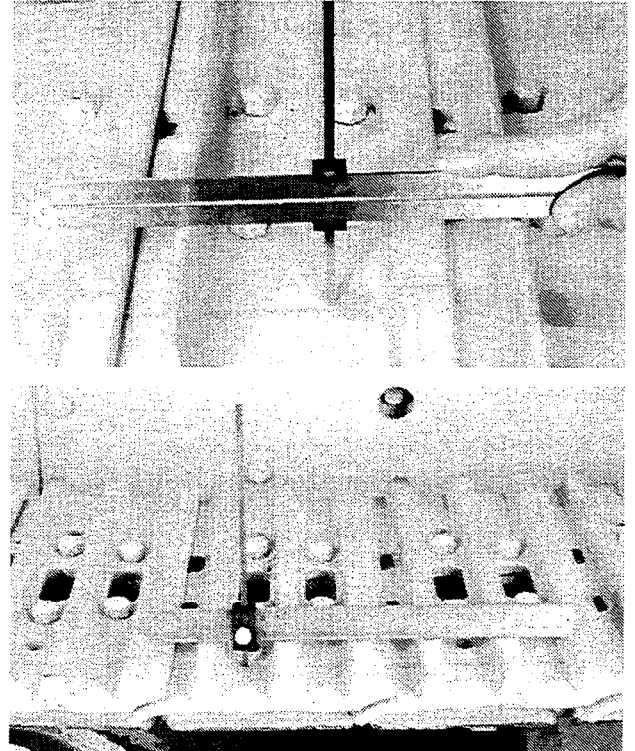

2AG:T93612, T93613 T47:0130 60350B 040285

MEASURE FRONT IDLER WEAR

1. Measure front idler wear using a depth gauge from undercarriage inspection service tool kit. Put crossbar of depth gauge on a cleaned surface of the center flange. The crossbar must be flat against the surface and parallel to the idler shaft. Push scale against tread surface so it is square against the most worn area. Make sure scale is not at an angle.
2. Measure the outside tread and then the inside tread opposite it to the nearest 0.020 in. (0.5 mm). Record the average inside and outside tread dimensions. Measure in several locations around the idler to confirm the consistency of wear.

FRONT IDLER SPECIFICATION

Flange height of new front idler	19.3 mm (0.76 in.)
Maximum recommended flange height for rebuilding	24.4 mm (0.96 in.)

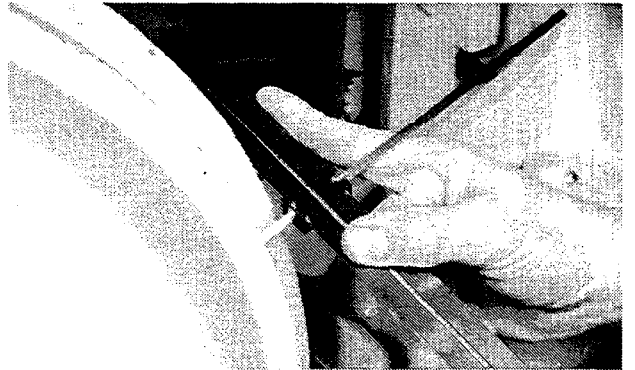

2AG:T93615 T47:0130 60350C 040285

MEASURE SPROCKET WEAR

1. Measure sprocket wear using appropriate sprocket wear gauge from undercarriage inspection service tool kit.
2. Place gauge on sprocket with gauge against one sprocket tooth.
3. Measure gap between the other side of the gauge and sprocket tooth. Allowable wear is indicated on the gauge.

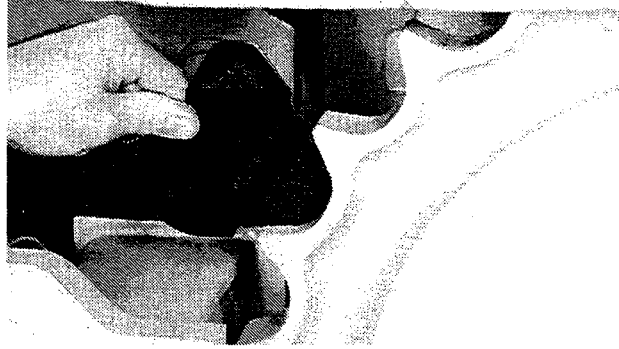

2AG;T93614 T47;0130 6035DD 040285

MEASURE UPPER TRACK CARRIER ROLLER WEAR

1. Measure carrier roller wear of both treads using a roller calipers and scale. Position calipers over the most worn area of the roller running surface, and close until caliper tips just touch tread surface. Measure caliper tip spread using the scale to the nearest 0.020 in. (0.5 mm).
2. Also check for flat spots on carrier roller tread, which indicate roller is not free to turn.

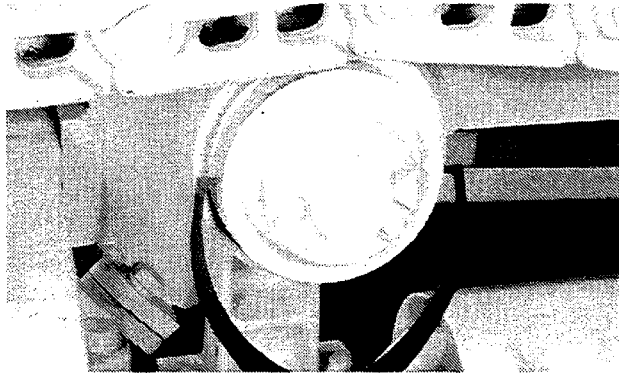

CARRIER ROLLER WEAR SPECIFICATION

O.D. of new carrier roller	152.4 mm (6.0 in.)
Minimum recommended O.D.	139.7 mm (5.5 in.)

2AG;T93616 T47;0130 6035DE 040285

MEASURE TRACK ROLLER WEAR

1. Raise unit off the ground and block it for support. Release track tension by loosening track adjusting cylinder nut and turning set screw counterclockwise approximately three turns.

2. Clean track roller to be measured.

3. Measure track roller using roller calipers and a scale. Measure inside and outside tread diameters of the roller at the area of most wear using the calipers. Then measure caliper tip spread with the scale to nearest 0.020 in. (0.5 mm).

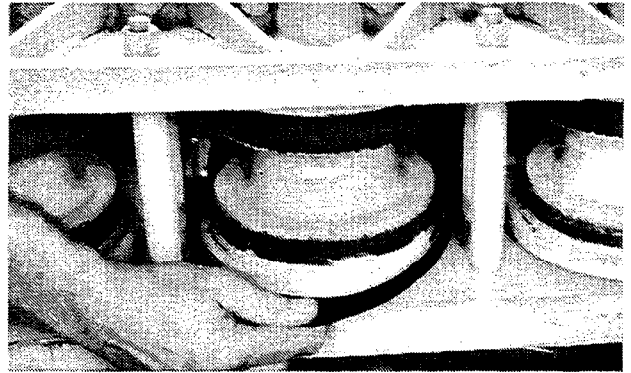

TRACK ROLLER WEAR SPECIFICATION

O.D. of new track roller	182.6 mm (7.19 in.)
Minimum recommended O.D.	168.2 mm (6.62 in.)

2AG;T93617 T47;0130 6035DF 040285

REMOVE AND INSPECT FRONT CROSSBAR

1. Remove front and rear bottom guard.
2. Remove track chain. (See instructions in this group).
3. Remove dozer (if equipped). (See Group 3201).
4. Remove track frame. (See instructions in this group).
5. Install hoist. Remove five cap screws and washers (A) from R.H. and L.H. side of front crossbar. Remove front crossbar and inspect. Replace only if necessary.

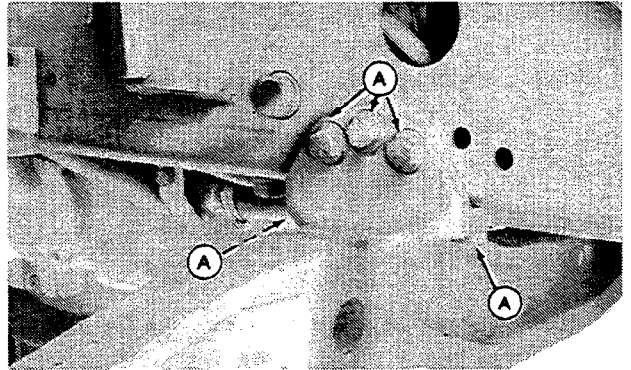

2AG;T93618 T47;0130 105 250783

INSTALL FRONT CROSSBAR

1. Install three cap screws (A) to R.H. and L.H. side of front crossbar. Tighten to 339 ± 34 N·m (250 ± 25 lb-ft).
2. Install two cap screws (B) to R.H. and L.H. side frame vertical. Tighten to 474.6 ± 12.46 N·m (350 ± 35 lb-ft).
3. Install track frame. (See instructions in this group).
4. Install dozer (if equipped). (See Group 3201).
5. Install track chain. (See instructions in this group).
6. Install front and rear bottom guard.

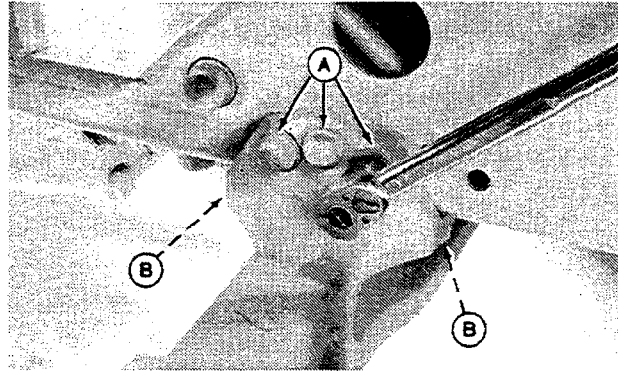

2AG;T93619 T47;0130 106 250783

REMOVE AND INSPECT REAR CROSSBAR

1. Remove rear bottom guard and drawbar.
2. Remove track chain. (See Remove Track Chain in this group.)
3. Remove track frame. (See Remove Track Frame in this group.)
4. Install hoist on crossbar. Remove four cap screws (C) and washers from R.H. and L.H. side of rear crossbar. Remove crossbar and inspect for wear or damage.
5. Inspect bracket cap (B) and rear bar bracket (E). Replace both as a unit if either one requires replacement.
6. Remove four cap screws (A) and washer and cap screw (D), washer and nut.

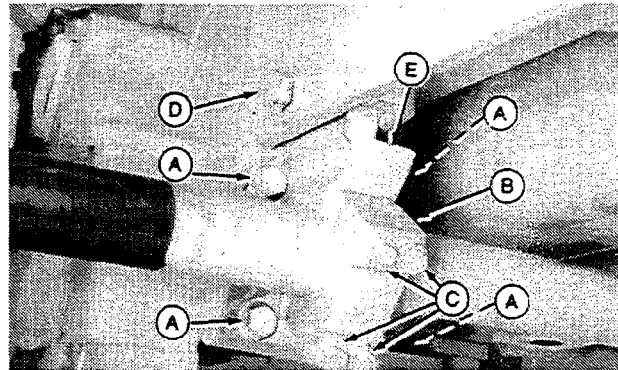

- | | |
|----------------------|--------------------|
| A—Cap Screw (4 used) | D—Cap Screw |
| B—Bracket Cap | E—Rear Bar Bracket |
| C—Cap Screw (4 used) | |

2AG;T93620 T47;0130 6035DG 040285

INSTALL REAR CROSSBAR

1. Install rear bar bracket (A). Install four cap screws (B and E) and washers. Apply LUBRIPLATE lubricant to cap screws (B). Tighten cap screws (B and E) to 407 ± 41 N·m (300 ± 30 lb-ft).
2. Install cap screw (F) and washer. Tighten cap screw to 407 to 909 N·m (300 to 670 lb-ft).
3. Install rear crossbar, bracket cap (C) and four cap screws (D) and washers. Tighten cap screws to 339 ± 39.5 N·m (250 ± 25 lb-ft).
4. Install track frame. (See Install Track Frame in this group).
5. Install track chain. (See Install Track Chain in this group).
6. Install drawbar and rear bottom guard.

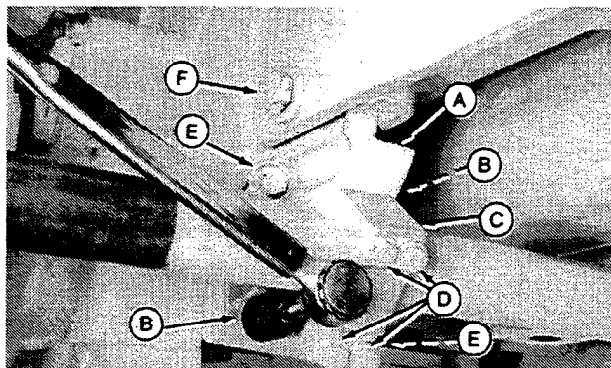

A—Rear Bar Bracket	D—Cap Screw (4 used)
B—Cap Screw (2 used)	E—Cap Screw (2 used)
C—Bracket Cap	F—Cap Screw

2AG/T93621 T47;0130 6035DH 040285

<https://www.ebooklibonline.com>

Hello dear friend!

Thank you very much for reading.

Enter the link into your browser.

The full manual is available for immediate download.

<https://www.ebooklibonline.com>

Section 02 AXLES AND SUSPENSION SYSTEMS

CONTENTS

	Page
GROUP 0250—AXLE SHAFT, BEARING AND REDUCTION GEARS	
Essential Tools	0250-01
Service Equipment and Tools	0250-01
Other Materials	0250-02
Specifications	0250-02
Final Drive	
Remove	0250-03
Disassemble	0250-05
Assemble	0250-08
Adjust Preload	0250-11
Install	0250-12
Steering Clutch and Brake Band	
Remove	0250-13
Disassemble	0250-16
Inspect	0250-17
Repair Brake Anchor and Band	0250-18
Assemble	0250-18
Install	0250-21
Brake Lever Shaft and Bushings	
Remove and Install	0250-22
Steering Clutch Housing	
Remove	0250-23
Install	0250-24
Steering and Brake Control Linkage	
Repair	0250-25

AXLE SHAFT, BEARINGS AND REDUCTION GEARS**ESSENTIAL TOOLS**

NOTE: Order tools from your SERVICE-GARD™ Catalog. Some tools may be available from a local supplier.

Number	Name	Use
JDG-91	Bearing Cup Installer	Install bearing cup.

T47;0250 6005DB 271184

SERVICE EQUIPMENT AND TOOLS

NOTE: Order tools from your SERVICE-GARD™ Catalog. Some tools may be available from a local supplier.

Name	Use
7/16-14 UNC Male Adapter	To remove final drive input shaft.
*Final Drive Housing Lifting Tool	To lift final drive housing during removal and installation
*Flanged Axle Shaft Removing Tool	To remove final drive flanged axle.
25 mm Disk 27 mm Disk 65 mm Disk 82 mm Disk 87 mm Disk 108 mm Disk 114 mm Disk	Install bushings, seals and bearing cups.
Slide Hammer Puller	Pull pinion and drive shaft.
Dial Indicator	To adjust axle shaft and final drive pinion shaft preload.

**Fabricated tools, dealer made. (See Section 99 for instructions to make tool.)*

T47;0250 6031DC 100185

OTHER MATERIALS

Number	Name	Use
T43514	John Deere LOCTITE® Plastic Gasket	Apply to all sealing mating surfaces.
T43512	John Deere LOCTITE Thread Lock and Sealer (medium strength)	Apply to lower two cap screws of final drive housing and set screw in steering brake drum.
TY9375	John Deere LOCTITE Pipe Sealant with TEFLON®	Apply to lower cap screw on quill of final drive housing.

LOCTITE is a trademark of Loctite Corp.
TEFLON is a trademark of DuPont Co.

T47;0250 6031DA 100185

SPECIFICATIONS

Item	Measurement	Specification
Final drive inner bearing cover cap screws	Torque	67.8 ± 6.78 N·m (50 ± 5 lb-ft)
Final drive housing to steering clutch housing cap screws	Torque	325.44 ± 32.54 N·m (240 ± 24 lb-ft)
Steering clutch housing to final drive housing cap screws	Torque	325.44 ± 32.54 N·m (240 ± 24 lb-ft)
Input shaft bearing quill cap screws .	Torque	115 ± 11 N·m (85 ± 8 lb-ft)
Clutch drum to input shaft set screw	Torque	14 N·m (10 lb-ft) and back out 1/4 turn
Final drive pinion shaft	Preload	0.00—0.08 mm (0.00—0.003 in.)

T47;0250 6005DE 271184

REMOVE FINAL DRIVE ASSEMBLY

1. Disconnect track chain (See instructions in this group)
2. Remove drive sprocket. (See instructions in this group).
3. Remove plug (C) and drain final drive housing.
4. Remove plug (A) and drain steering clutch housing.
5. Remove two cap screws and washers (B).

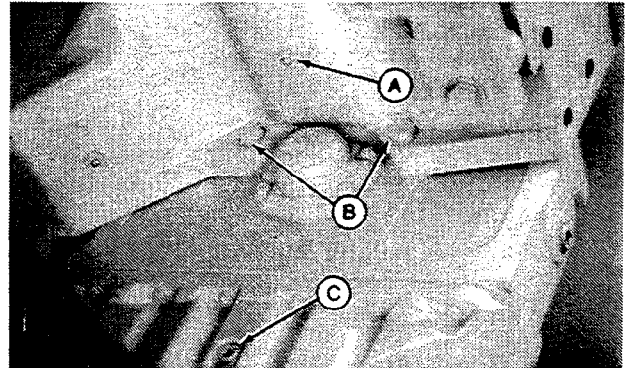

9AG;T93665 T47;0250 205 130783

6. Remove three cap screws to remove bearing quill (D).
7. Remove shims (E). Remove plug (A). Rotate steering clutch until set screw with jam nut (C) is visible in hole. Remove set screw and replace with 3/8 x 3 in. cap screw and washer (B). This will support the drum and keep it in alignment for removal of pinion and steering clutch shaft.

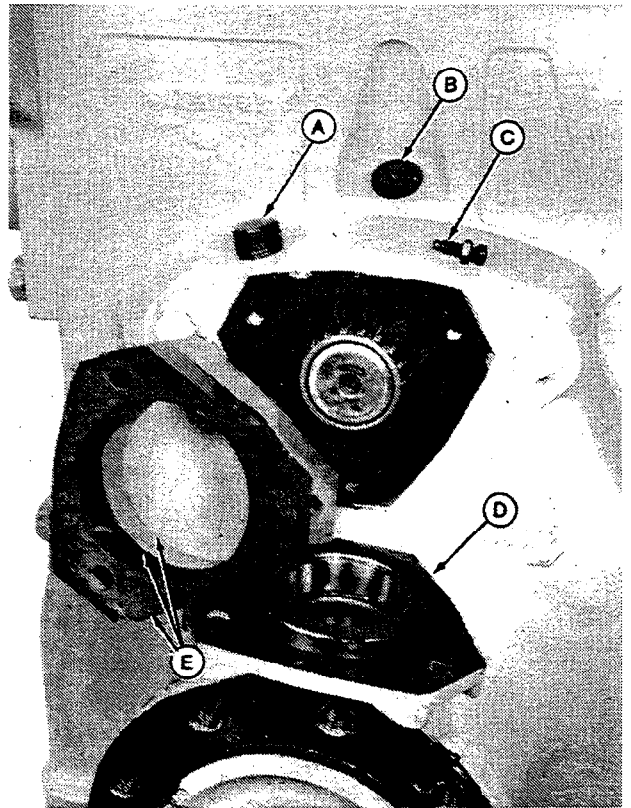

- | | |
|-------------------------|---------|
| A—Plug | D—Quill |
| B—Cap Screw and Washer | E—Shims |
| C—Set Screw and Jam Nut | |

9AG;T93666 T47;0250 206 130783

8. Remove input shaft using a 7/16"-14 UNC male adapter and slide hammer. If shaft does not come out easily, tap bearing with a small drift to eliminate binding on the shaft. Lift out inner bearing.

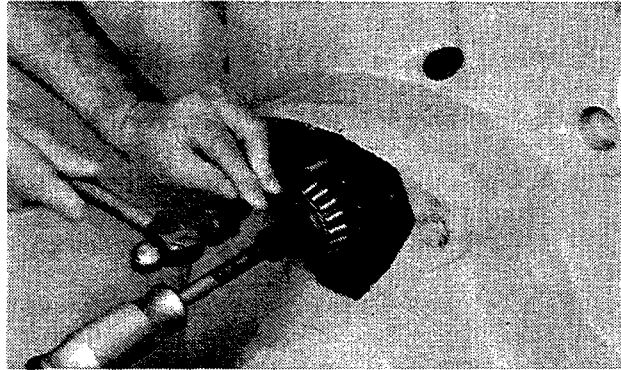

9AG:T91344 T47:0250 6005DF 271184

9. Remove the upper two final drive-to-steering clutch housing cap screws. Install special lifting tool (A), which can be made of 12.7 mm (1/2 in.) round stock. Secure yoke clamp (B) with two cap screws.

10. Attach sling. Remove the lower two cap screws (C) and separate final drive housing from steering clutch housing.

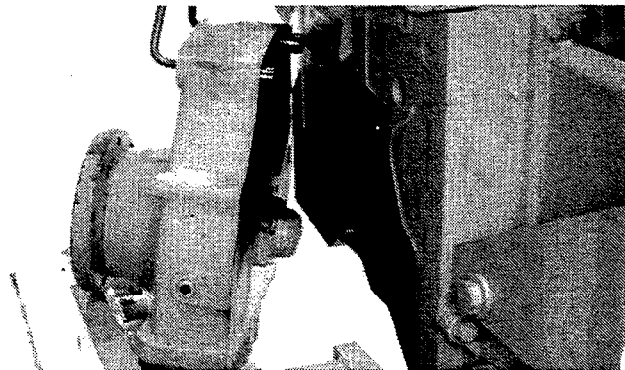
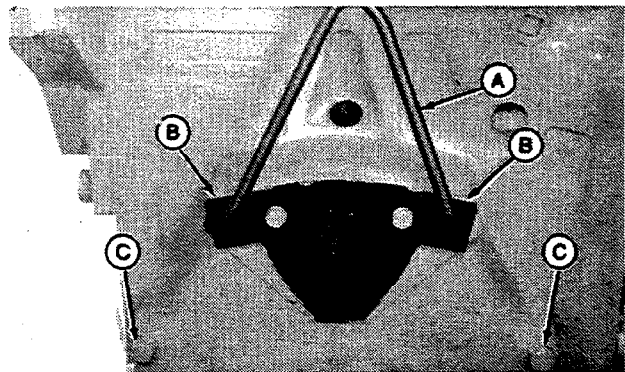

9AG:T93667, T93668 T47:0250 6005DG 271184



Suggest:

If the above button click is invalid.

Please download this document

first, and then click the above link

to download the complete manual.

Thank you so much for reading

DISASSEMBLE FINAL DRIVE ASSEMBLY

1. Remove 12 cap screws and lock washers to remove oil pan (A) and gasket.
2. Remove four cap screws and lock washers to remove cover (B) and gasket.

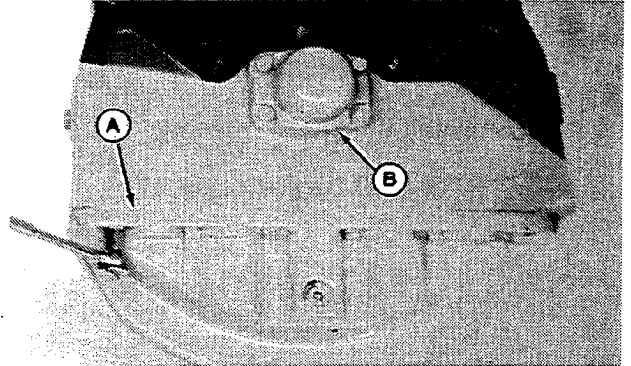

9AG;T93669 T47;0250 209 130783

3. Remove cotter pin to remove nut (A) and special washer (B).

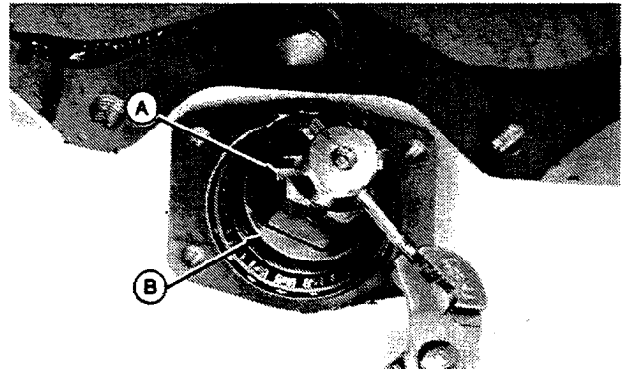

9AG;T93670 T47;0250 210 130783

4. Invert nut (A) which was removed and install on flanged axle. Install Flanged Axle Shaft Removing Tool (B) with four cap screws (3/8 x 2-1/2 in.). Tighten cap screws evenly to push flanged axle from its seat. Remove tool and nut.

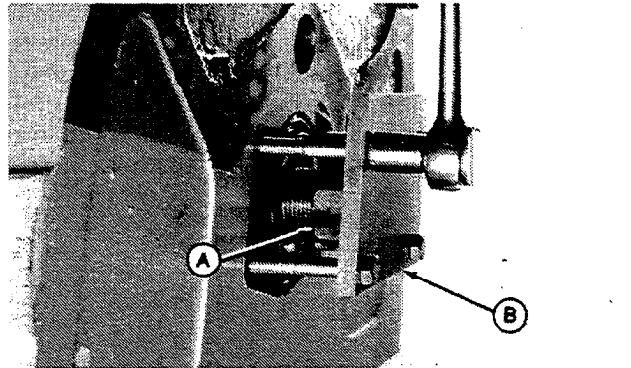

9AG;T93671 T47;0250 211 130783