

**John Deere  
JD544B  
Loader**

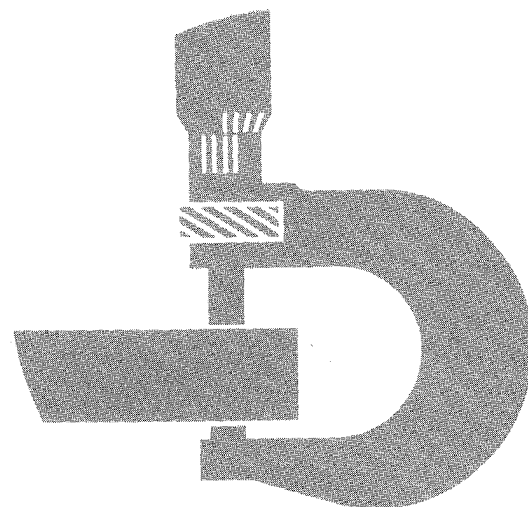

**TECHNICAL MANUAL**

**John Deere Dubuque Works  
TM-1094 (Jan-80)**

LITHO IN U.S.A.

# JD544-B LOADER

Technical Manual  
TM-1094 (Jan-80)

## CONTENTS

### Section 10 - GENERAL

- Group 5 Specifications
- Group 10 Predelivery, Delivery, and After-Sale Services
- Group 15 Lubrication

### Section 20 - ENGINE

- Group 5 Engine Removal and Installation
- Group 10 Basic Engine
- Group 15 Engine Lubrication System
- Group 20 Engine Cooling System
- Group 25 Fuel System
- Group 30 Speed Control Linkage (Refer to Section 70)
- Group 35 Air Intake System
- Group 40 Specifications and Special Tools

### Section 30 - ELECTRICAL SYSTEM

- Group 5 Batteries
- Group 10 Charging System
- Group 15 Delco-Remy Starting System
- Group 20 John Deere Starting System
- Group 25 Miscellaneous Electrical Components
- Group 26 Heating and Air Conditioning Systems
- Group 30 Specifications and Special Tools

### Section 40 - POWER TRAIN

- Group 5 Drive Shafts
- Group 10 Damper Assembly
- Group 15 Transmission
- Group 20 Final Drives
- Group 25 Differential
- Group 30 Specifications and Special Tools

### Section 50 - HYDRAULIC SYSTEM

- Group 5 Transmission Pump
- Group 10 Transmission Control Valve
- Group 15 Steering and Brake Pump
- Group 20 Steering Valve
- Group 25 Brake System
- Group 30 Loader Pump
- Group 35 Loader Control Valve
- Group 40 Cylinders
- Group 45 Miscellaneous Hydraulic Components
- Group 47 Backhoe Swing Cylinder
- Group 49 Backhoe Control Valve
- Group 50 Specifications and Special Tools

### Section 60 - MISCELLANEOUS COMPONENTS

- Group 5 Loader and Engine Frames
- Group 10 Loader Boom and Buckets
- Group 15 Seats
- Group 20 Canopy and Cab
- Group 21 Backhoe
- Group 25 Specifications and Special Tools

### Section 70 - SYSTEM TESTING

- Group 5 General Information - Seven Basic Steps of Testing and Diagnosis
- Group 10 Engine
- Group 15 Electrical System
- Group 16 Heating and Air Conditioning Systems
- Group 20 Power Train
- Group 25 Hydraulic System
- Group 26 Hydraulic System (Analyzer)
- Group 30 Miscellaneous Components
- Group 35 Specifications and Special Tools

## INDEX

*The specifications and design information contained in this manual were correct at the time this machine was manufactured. It is John Deere's policy to continually improve and update our machines. Therefore, the specifications and design information are subject to change without notice. Wherever applicable, specifications and design information are in accordance with SAE and ICED standards.*

Copyright© 1973  
DEERE & COMPANY  
Moline, Illinois  
All rights reserved

## INTRODUCTION

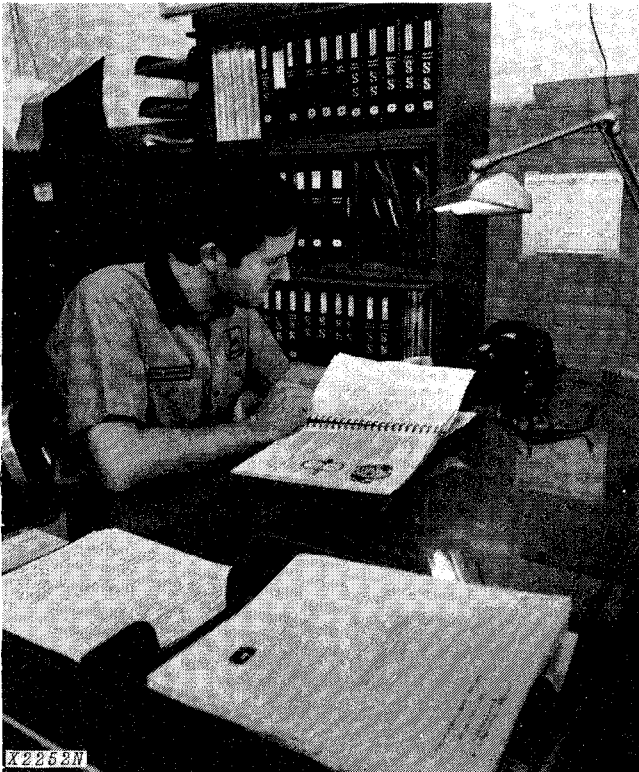

Use FOS Manuals for Reference

This technical manual is part of a twin concept of service:

The two kinds of manuals work as a team to give you both the general background and technical details of shop service.

### •FOS Manuals—for reference

*Fundamentals of Service (FOS) Manuals* cover basic theory of operation, *fundamentals* of trouble shooting, *general* maintenance, and *basic* types of failure and their causes. FOS Manuals are for training new personnel and for reference by experienced technicians.



When a service technician should refer to a FOS Manual for more information, a FOS symbol like the one at the left is used in the TM to identify the reference.

### •Technical Manuals—for actual service

*Technical Manuals* are concise service guides for a specific machine. Technical manuals are on-the-job guides containing only the vital information needed by an experienced service technician.

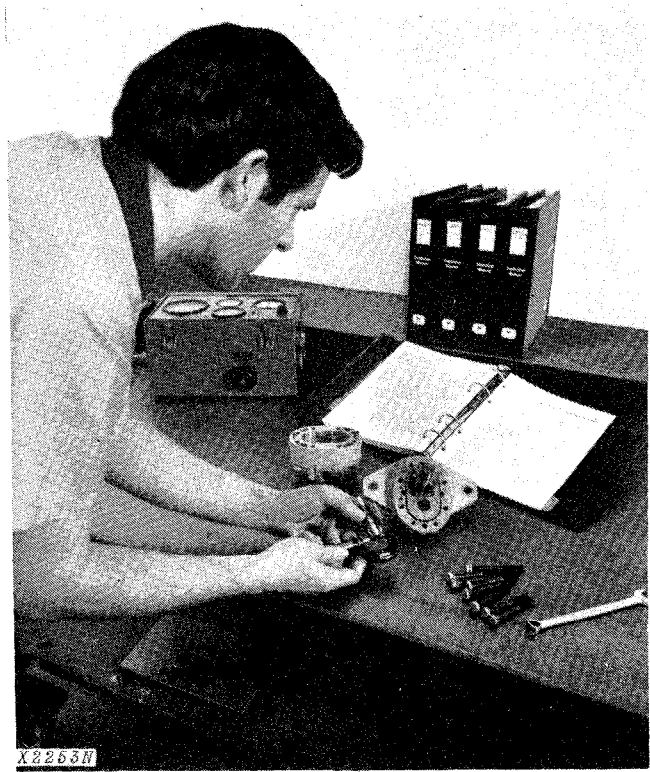

Use Technical Manuals for Actual Service

This technical manual was planned and written for you, an experienced service technician. Keep it in a permanent binder in the shop where it is handy. Refer to it whenever in doubt about correct service procedures or specifications.

Some features of this manual:

- Inside front cover - "Table of Contents" and "Maintenance Without Accident".
- Section 10 - General specifications and services.
- Sections 20 through 60 - Removal, repair testing (components removed), installation, and adjustment.
- Section 70 - Detailed explanation of system operation, diagnosis, visual inspection, testing, and adjustments.
- Specifications grouped and illustrated at the end of each section.

**<https://www.ebooklibonline.com>**

Hello dear friend!

Thank you very much for reading.

Enter the link into your browser.

The full manual is available for immediate download.

**<https://www.ebooklibonline.com>**

## MAINTENANCE WITHOUT ACCIDENT WORK SAFELY



T27999



This safety alert symbol identifies important safety messages in this manual and on the loader. When you see this symbol, be alert to the possibility of personal injury and carefully read the message that follows.

**EVERY EMPLOYER HAS A  
SAFETY PROGRAM. KNOW  
WHAT IT IS!**

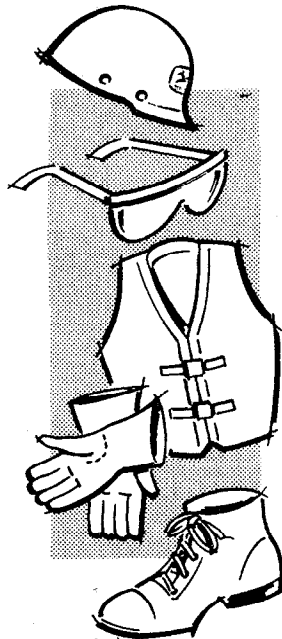

T27501N

Consult your shop supervisor for specific instructions on a job, and the safety equipment required.

For instance, you may need: Hard hat, safety shoes, safety goggles, heavy gloves, reflector vests, ear protectors, respirators.

Litho in U.S.A.



T27502N

**ALWAYS AVOID** loose clothing or any accessory—flopping cuffs, dangling neckties and scarves, or rings and wrist watches—that can catch in moving parts and put you out of work.



T32701N

### BE ALERT!

Plan ahead—work safely—avoid accidental damage and injury. If a careless moment does cause an accident or fire, react quickly with the tools and skills at hand—know how to use a first aid kit and a fire extinguisher—and where to get aid and assistance. In an emergency, split-second action is the key to safety.

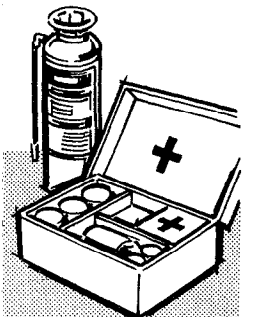

T27504N

## MAINTENANCE WITHOUT ACCIDENT

Specific safety procedures should always be observed, whether servicing the equipment or making the repairs. Remembering these—in time!—can prevent an injury . . . or save your life. . . .

### AVOID FIRE HAZARDS—

#### Fuel Is Dangerous!

Don't smoke while refueling.

Don't smoke while handling highly flammable material.

Engine should be shut off when refueling.

Use care in refueling if the engine is hot.

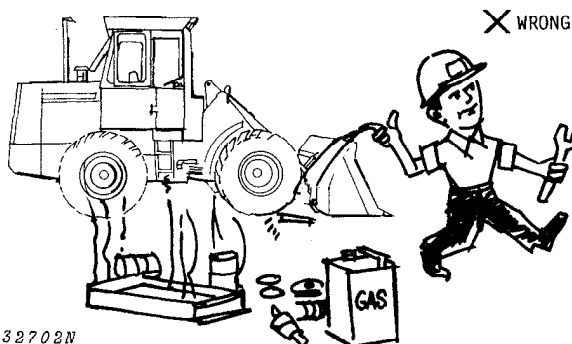

T32702N

Don't use open pans of gasoline or diesel fuel for cleaning parts. Good commercial, nonflammable solvents are preferred.

#### Battery Gas Is Highly Flammable

Provide adequate ventilation when charging batteries.



T27506N

Don't check battery charge by placing metal objects across the posts.

Don't allow sparks or open flame near batteries.

Don't smoke near battery.

#### Flame Is Not a Flashlight!

Never check fuel, battery electrolyte or coolant levels with an open flame.

Never use an open flame to look for leaks anywhere on the equipment.

Never use an open flame as a light anywhere on or around the equipment.

**KNOW WHERE FIRE EXTINGUISHERS ARE KEPT!**

Litho in U.S.A.

### UNDER ALL MAINTENANCE CONDITIONS—

Do not perform any work on the equipment unless authorized to do so. Then be sure you know what you're doing. Follow recommended procedures.

Never service the equipment while it is being operated.

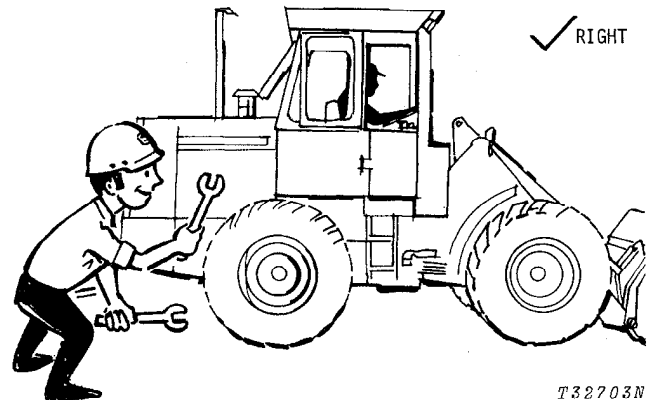

T32703N

Avoid working on equipment with the engine running. If it is necessary to make checks with the engine running, **ALWAYS USE TWO SERVICE TECHNICIANS**—one, the operator, at the controls, the other checking within sight of the operator. Also, put the transmission in neutral, set the parking brake, and apply any safety locks provided. **KEEP HANDS AWAY FROM MOVING PARTS.**



T27508N

## MAINTENANCE WITHOUT ACCIDENT

Before servicing, adjusting, or repairing loaders which have attachments such as log and lumber forks, buckets, etc.—**LOWER** attachments to the ground—or, if necessary to raise them for access to certain parts, **SECURELY SUPPORT** by external means. **DO NOT** rely on controls to support or position attachments for maintenance.

Never allow **ANYONE** to walk under equipment that is raised and not properly blocked.

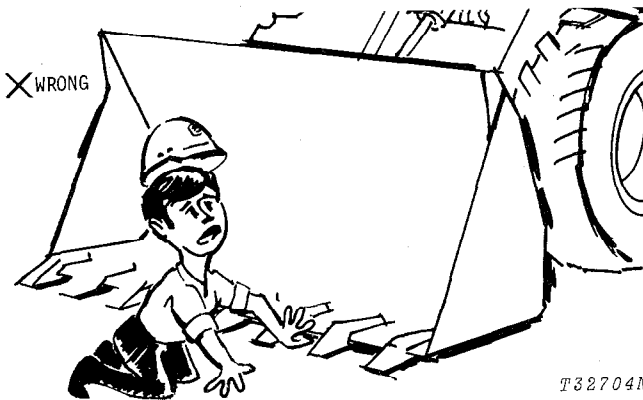

Avoid working directly under raised and blocked equipment unless absolutely necessary.

If the machine is on an incline, block it securely.

Use hoisting equipment for lifting heavy parts. **TAKE CARE! WATCH OUT FOR OTHER PEOPLE IN THE VICINITY.**

Use extreme caution in removing radiator caps, drain plugs, grease fittings, or hydraulic pressure caps.

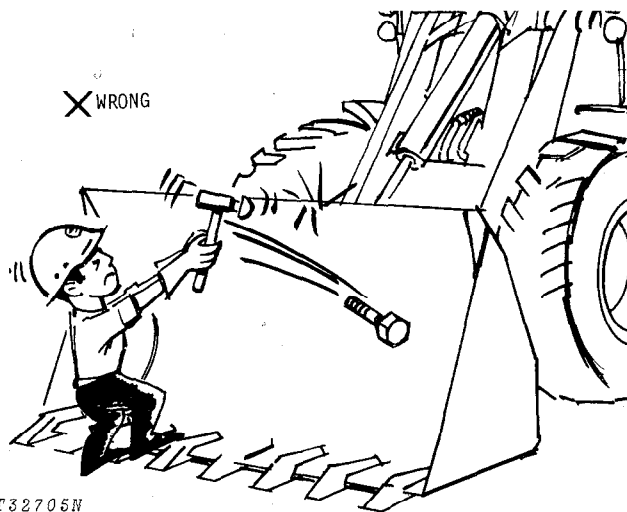

Wear safety glasses when drilling, grinding, or hammering metal.

Make sure the maintenance area is adequately vented.

Keep maintenance area **CLEAN AND DRY**. Oily and wet floors are slippery; greasy rags are a fire hazard; wet spots are dangerous when working with electrical equipment.

Store starting aids in a cool and well-ventilated place, out of the reach of unauthorized personnel.

### SERVICING PRECAUTIONS

Stop the engine before cleaning or lubricating the equipment.

Lower mounted equipment and tools to the ground *carefully*.

Engine coolant gets hot! Don't remove the radiator cap until coolant temperature is below the boiling point. Then turn cap slightly to relieve pressure before removing.

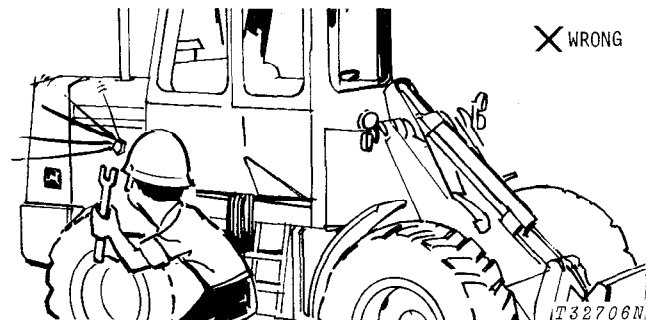

Exhaust gases are dangerous! Periodically check exhaust system for excessive leakage.

Don't forget a hydraulic system may be pressurized! To relieve pressure, follow the technical manual.

The loader is equipped with a hydraulic accumulator—recharge by using only dry nitrogen. Again follow the technical manual for procedure.

When checking hydraulic pressure, be sure to use the correct test gauge for the pressure in the particular system.

## MAINTENANCE WITHOUT ACCIDENT

RIGHT ✓

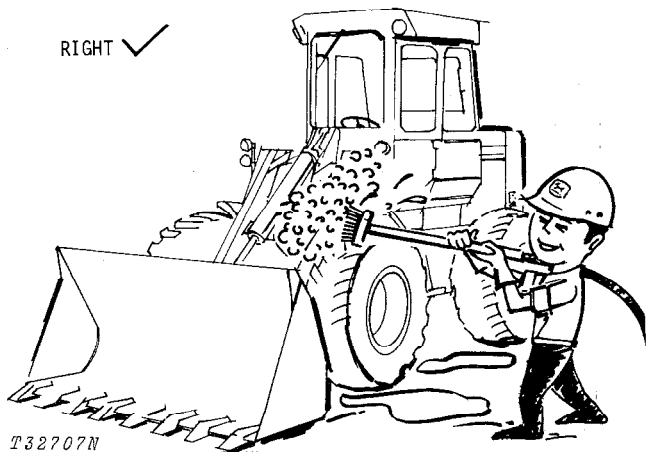

T32707N

Keep ALL equipment free of dirt and oil. This attention will minimize fire hazards and facilitate spotting of loose or defective parts.

When preparing engine for storage, remember that inhibitor is volatile and therefore dangerous. Seal and tape openings after adding the inhibitor. Keep container tightly closed when not in use.

### ADJUSTING PRECAUTIONS

#### ....for Operating Adjustments

Keep clutch and brake control units properly adjusted at all times. Before making adjustments, stop engine.

X WRONG



T32708N

Before removing any housing covers, stop engine. Take all objects from your pockets which could fall into the opened housings. Don't let adjusting wrenches fall into opened housings.

#### ....for Maintenance Adjustments

X WRONG



T32709N

Don't attempt to check belt tension while the engine is running.

Don't adjust the fuel system while the machine is in motion.

## MAINTENANCE WITHOUT ACCIDENT

### PRECAUTIONS DURING REPAIR

**⚠ CAUTION:** Escaping fluid under pressure can have sufficient force to penetrate the skin, causing serious personal injury. Before disconnecting lines, be sure to relieve all pressure. Before applying pressure to the system, be sure all connections are tight and that lines, pipes and hoses are not damaged. Fluid escaping from a very small hole can be almost invisible. Use a piece of cardboard or wood, rather than hands, to search for suspected leaks.

If injured by escaping fluid, see a doctor at once. Serious infection or reaction can develop if proper medical treatment is not administered immediately.

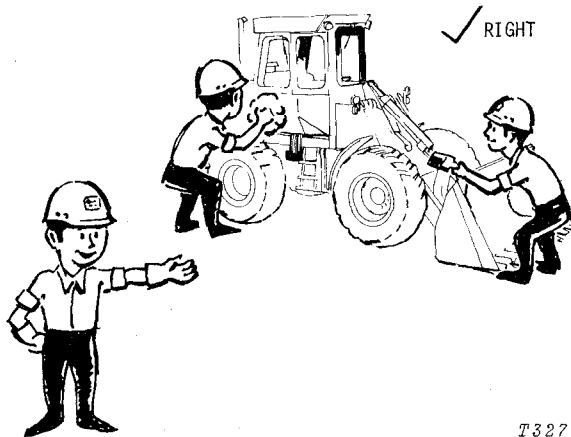

Keep all components free of dirt and oil. This attention will minimize fire hazards and facilitate spotting of loose or defective parts.

Before working on hydraulic system—make sure engine is not running and the system pressure is relieved by working the control levers in all directions with the engine shut off.

Before repairing the electrical system, or performing a major overhaul, make sure the batteries are disconnected.

When changing cutting edges on bucket—  
Stop the engine and securely block the bucket.

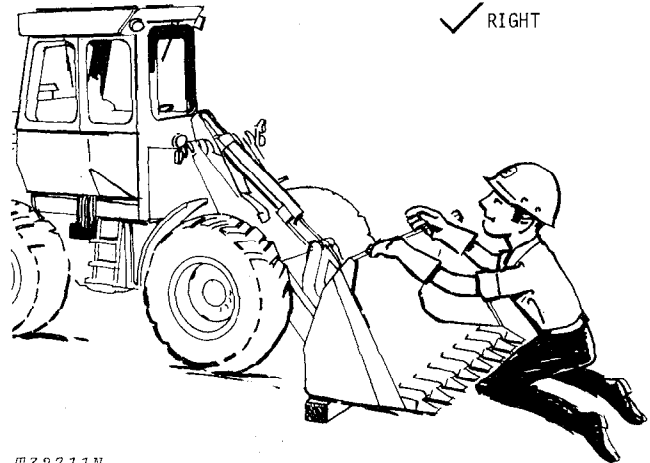

T32711N

Never let your bare hands come in contact with the sharp edges. WEAR GLOVES.

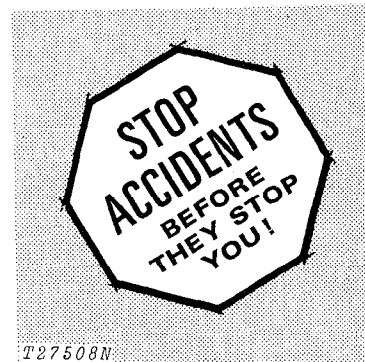

T27508N

## MAINTENANCE WITHOUT ACCIDENT

### KNOW EQUIPMENT IS READY!

Check guards, canopies, safety bars—all protective devices installed on the loader. Every one should be in place and secure.

### CHECK IT OUT!

- GUARDS
- CANOPIES
- SHIELDS
- PROTECTIVE DEVICES
- ROLL-OVER PROTECTIVE STRUCTURES
- SEAT BELTS, ETC.

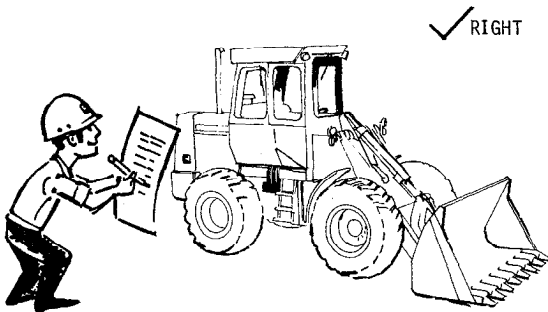

T32712N

Carefully inspect equipment for visual defects—leaks in fuel, lubrication, and hydraulic systems. Do not search for pressurized fluid leaks with your hands. Use cardboard or wood to search for leaks.

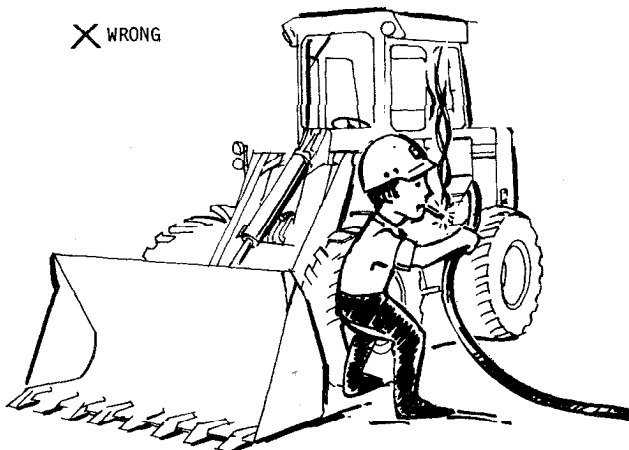

T32713N

Check levels of fuel, coolant, hydraulic fluid, and lubricating oil. If fuel must be added—**FIRST, PUT OUT THAT CIGARET.**

Check and secure all caps and filler plugs for fuel, oils, radiator, etc.

Litho in U.S.A.

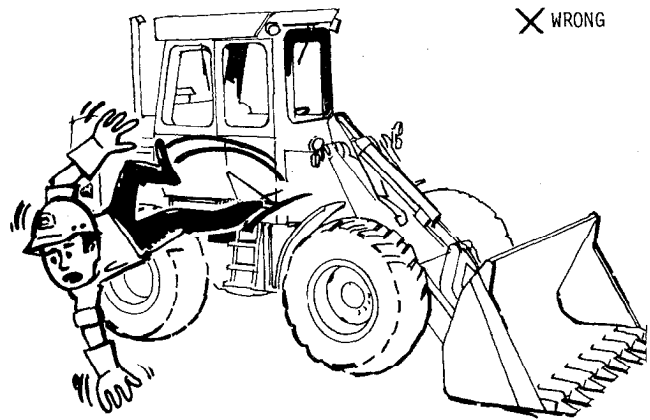

T32714N

Be sure to clean any oil, grease or mud accumulation from floor of operator's compartment, stepping points, and grab rails to minimize the danger of slipping.

In freezing weather beware of snow or ice deposits on stepping points, grab rails, and floor.

Remove loose bolts, tools, or other objects from floor of operator's compartment.

Although it is impractical to try to cover every possible maintenance situation, the safety precautions recommended here should serve to develop and promote safe maintenance procedures.

The information contained in this manual is not intended to replace safety codes, insurance requirements, federal, state, and local laws, rules and regulations. In particular, your service area or jobsite activities may be subject to state safety rules and/or federal regulation under the Occupational Safety and Health Act (OSHA). Familiarize yourself with all regulations applicable to your situation in order to avoid possible safety violations.

Illustrations and copy reproduced in part by permission of Construction Industry Manufacturers' Association (CIMA).

**COMPLETE PAGE LISTING  
 WITH LATEST DATE LINES**

1,2	(Jan-80)	20-40-1,2	(Jan-80)	30-26-15,16	(Jan-80)
3,4	(Nov-78)	20-40-3,4	(Jan-80)	30-26-17,18	(Jan-80)
5,6	(Nov-78)	20-40-5,6	(Jan-80)	30-26-19,20	(Jan-80)
7,8	(Nov-78)	20-40-7,8	(Jan-80)	30-26-21,22	(Jan-80)
9,10	(Jan-80)	20-40-9,10	(Nov-78)	30-26-23,24	(Jan-80)
11,12	(Jan-80)	20-40-11,12	(Jan-80)	30-26-25,26	(Jan-80)
10-5-1,2	(Jan-80)	20-40-13,14	(Jan-80)	30-26-27,28	(Jan-80)
10-5-3,4	(Nov-78)	20-40-15,16	(Nov-78)	30-30-1,2	(Nov-78)
10-10-1,2	(Nov-78)	20-40-17,18	(Nov-78)	30-30-3,4	(Nov-78)
10-10-3,4	(Nov-78)	20-40-19,20	(Jan-80)	30-30-5,6	(Nov-78)
10-10-5,6	(Nov-78)	20-40-21,22	(Nov-78)	30-30-7,8	(Nov-78)
10-10-7,8	(Nov-78)	20-40-23,24	(Jan-80)	30-30-9,10	(Nov-78)
10-10-9,10	(Jan-80)	20-40-25,26	(Jan-80)	30-30-11,12	(Nov-78)
10-10-11,12	(Nov-78)	20-40-27,28	(Jan-80)	30-30-13,14	(Nov-78)
10-10-13,14	(Jan-80)	30-5-1,2	(Jan-80)	30-30-15,16	(Jan-80)
10-10-15,16	(Nov-78)	30-5-3,4	(Nov-78)	30-30-17,18	(Jan-80)
10-10-17,18	(Jan-80)	30-5-5,6	(Nov-78)	40-5-1,2	(Jan-80)
10-10-19,20	(Nov-78)	30-10-1,2	(Jan-80)	40-5-3,4	(Nov-78)
10-10-21,22	(Nov-78)	30-10-3,4	(Nov-78)	40-10-1,2	(Nov-78)
10-10-23,24	(Nov-78)	30-10-5,6	(Nov-78)	40-15-1,2	(Nov-78)
10-10-25,26	(Nov-78)	30-10-7,8	(Nov-78)	40-15-3,4	(Jan-80)
10-10-27,28	(Nov-78)	30-10-9,10	(Nov-78)	40-15-5,6	(Jan-80)
10-15-1,2	(Jan-80)	30-10-11,12	(Nov-78)	40-15-7,8	(Nov-78)
20-5-1,2	(Jan-80)	30-10-13,14	(Nov-78)	40-15-9,10	(Nov-78)
20-5-3,4	(Jan-80)	30-10-15,16	(Nov-78)	40-15-11,12	(Nov-78)
20-10-1,2	(Jan-80)	30-10-17,18	(Nov-78)	40-15-13,14	(Jan-80)
20-10-3,4	(Jan-80)	30-10-19,20	(Nov-78)	40-15-15,16	(Nov-78)
20-10-5,6	(Jan-80)	30-10-21,22	(Nov-78)	40-15-17,18	(Jan-80)
20-10-7,8	(Jan-80)	30-15-1,2	(Nov-78)	40-15-19,20	(Jan-80)
20-10-9,10	(Jan-80)	30-15-3,4	(Nov-78)	40-15-21,22	(Nov-78)
20-10-11,12	(Jan-80)	30-15-5,6	(Nov-78)	40-15-23,24	(Nov-78)
20-10-13,14	(Jan-80)	30-15-7,8	(Nov-78)	40-15-25,26	(Jan-80)
20-10-15,16	(Jan-80)	30-15-9,10	(Nov-78)	40-15-27,28	(Jan-80)
20-10-17,18	(Jan-80)	30-20-1,2	(Nov-78)	40-15-29,30	(Jan-80)
20-10-19,20	(Jan-80)	30-20-3,4	(Nov-78)	40-15-31,32	(Nov-78)
20-10-21,22	(Jan-80)	30-20-5,6	(Nov-78)	40-15-33,34	(Nov-78)
20-15-1,2	(Jan-80)	30-20-7,8	(Nov-78)	40-15-35,36	(Jan-80)
20-15-3,4	(Jan-80)	30-20-9,10	(Nov-78)	40-15-37,38	(Nov-78)
20-20-1,2	(Nov-78)	30-25-1,2	(Jan-80)	40-15-39,40	(Nov-78)
20-20-3,4	(Nov-78)	30-25-3,4	(Jan-80)	40-20-1,2	(Nov-78)
20-25-1,2	(Nov-78)	30-25-5,6	(Jan-80)	40-20-3,4	(Nov-78)
20-25-3,4	(Nov-78)	30-25-7,8	(Nov-78)	40-20-5,6	(Nov-78)
20-25-5,6	(Jan-80)	30-26-1,2	(Nov-78)	40-25-1,2	(Jan-80)
20-25-7,8	(Nov-78)	30-26-3,4	(Jan-80)	40-25-3,4	(Nov-78)
20-30-1,2	(Nov-78)	30-26-5,6	(Jan-80)	40-25-5,6	(Nov-78)
20-35-1,2	(Nov-78)	30-26-7,8	(Jan-80)	40-25-7,8	(Jan-80)
20-35-3,4	(Nov-78)	30-26-9,10	(Jan-80)	40-25-9,10	(Nov-78)
20-35-5,6	(Jan-80)	30-26-11,12	(Jan-80)	40-25-11,12	(Jan-80)
20-35-7,8	(Jan-80)	30-26-13,14	(Jan-80)	40-30-1,2	(Nov-78)
				40-30-3,4	(Jan-80)

Vertical lines indicate pages included in this revision.

## PAGE LISTING—Continued

40-30-5,6	(Nov-78)	50-45-7,8	(Nov-78)	70-5-1,2	(Nov-78)
40-30-7,8	(Jan-80)	50-45-9,10	(Jan-80)	70-10-1,2	(Nov-78)
40-30-9,10	(Jan-80)	50-45-11,12	(Jan-80)	70-10-3,4	(Nov-78)
40-30-11,12	(Jan-80)	50-45-13,14	(Nov-78)	70-10-5,6	(Nov-78)
40-30-13,14	(Jan-80)	50-47-1,2	(Nov-78)	70-10-7,8	(Nov-78)
40-30-15,16	(Jan-80)	50-47-3,4	(Nov-78)	70-10-9,10	(Jan-80)
		50-49-1,2	(Nov-78)	70-10-11,12	(Jan-80)
50-5-1,2	(Jan-80)	50-49-3,4	(Nov-78)	70-10-13,14	(Jan-80)
50-5-3,4	(Nov-78)	50-49-5,6	(Nov-78)	70-15-1,2	(Nov-78)
50-10-1,2	(Nov-78)	50-49-7,8	(Nov-78)	70-15-3,4	(Nov-78)
50-10-3,4	(Nov-78)	50-50-1,2	(Nov-78)	70-15-5,6	(Nov-78)
50-10-5,6	(Nov-78)	50-50-3,4	(Nov-78)	70-15-7,8	(Nov-78)
50-15-1,2	(Jan-80)	50-50-5,6	(Jan-80)	70-15-9,10	(Jan-80)
50-15-3,4	(Jan-80)	50-50-7,8	(Jan-80)	70-15-11,12	(Nov-78)
50-15-5,6	(Jan-80)	50-50-9,10	(Nov-78)	70-15-13,14	(Jan-80)
50-20-1,2	(Nov-78)	50-50-11,12	(Nov-78)	70-15-15,16	(Jan-80)
50-20-3,4	(Nov-78)	50-50-13,14	(Nov-78)	70-15-17,18	(Jan-80)
50-20-5,6	(Jan-80)	50-50-15,16	(Nov-78)	70-15-19,20	(Jan-80)
50-20-7,8	(Jan-80)	50-50-17,18	(Nov-78)	70-15-21,22	(Jan-80)
50-20-9,10	(Jan-80)	50-50-19,20	(Jan-80)	70-15-23,24	(Jan-80)
50-20-11,12	(Jan-80)	50-50-21,22	(Nov-78)	70-15-25,26	(Nov-78)
50-20-13,14	(Jan-80)	50-50-23,24	(Nov-78)	70-15-27,28	(Jan-80)
50-20-15,16	(Jan-80)	50-50-25,26	(Nov-78)	70-15-29,30	(Jan-80)
50-20-17,18	(Jan-80)	50-50-27,28	(Nov-78)	70-15-31,32	(Jan-80)
50-20-19,20	(Jan-80)	50-50-29,30	(Nov-78)	70-15-33,34	(Jan-80)
50-20-21,22	(Jan-80)	50-50-31,32	(Nov-78)	70-15-35,36	(Nov-78)
50-20-23,24	(Jan-80)	50-50-33,34	(Nov-78)	70-15-37,38	(Nov-78)
50-20-25,26	(Jan-80)	50-50-35,36	(Jan-80)	70-15-39,40	(Nov-78)
50-20-27,28	(Jan-80)			70-15-41,42	(Nov-78)
50-20-29,30	(Jan-80)	60-5-1,2	(Nov-78)	70-15-43,44	(Jan-80)
50-20-31,32	(Jan-80)	60-5-3,4	(Jan-80)	70-15-45,46	(Jan-80)
50-20-33,34	(Jan-80)	60-5-5,6	(Jan-80)	70-15-47,48	(Nov-78)
50-25-1,2	(Nov-78)	60-10-1,2	(Nov-78)	70-15-49,50	(Nov-78)
50-25-3,4	(Nov-78)	60-10-3,4	(Nov-78)	70-15-51,52	(Nov-78)
50-25-5,6	(Nov-78)	60-10-5,6	(Nov-78)	70-15-53,54	(Nov-78)
50-25-7,8	(Nov-78)	60-10-7,8	(Nov-78)	70-16-1,2	(Nov-78)
50-30-1,2	(Jan-80)	60-10-9,10	(Nov-78)	70-16-3,4	(Nov-78)
50-30-3,4	(Nov-78)	60-10-11,12	(Nov-78)	70-16-5,6	(Nov-78)
50-30-5,6	(Nov-78)	60-15-1,2	(Nov-78)	70-16-7,8	(Nov-78)
50-35-1,2	(Nov-78)	60-20-1,2	(Nov-78)	70-16-9,10	(Nov-78)
50-35-3,4	(Nov-78)	60-20-3,4	(Nov-78)	70-16-11,12	(Jan-80)
50-35-5,6	(Nov-78)	60-20-5,6	(Nov-78)	70-16-13,14	(Jan-80)
50-35-7,8	(Nov-78)	60-20-7,8	(Nov-78)	70-16-15,16	(Jan-80)
50-35-9,10	(Jan-80)	60-21-1,2	(Nov-78)	70-16-17,18	(Jan-80)
50-40-1,2	(Nov-78)	60-21-3,4	(Nov-78)	70-16-19,20	(Jan-80)
50-40-3,4	(Nov-78)	60-21-5,6	(Nov-78)	70-20-1,2	(Nov-78)
50-40-5,6	(Jan-80)	60-25-1,2	(Nov-78)	70-20-3,4	(Nov-78)
50-40-7,8	(Jan-80)	60-25-3,4	(Jan-80)	70-20-5,6	(Nov-78)
50-40-9,10	(Jan-80)			70-20-7,8	(Nov-78)
50-45-1,2	(Nov-78)			70-20-9,10	(Jan-80)
50-45-3,4	(Jan-80)			70-20-11,12	(Nov-78)
50-45-5,6	(Nov-78)			70-25-1,2	(Nov-78)
				70-25-3,4	(Nov-78)
				70-25-5,6	(Nov-78)

Vertical lines indicate pages included in this revision.

**PAGE LISTING—Continued**

70-25-7,8	(Nov-78)
70-25-9,10	(Nov-78)
70-25-11,12	(Nov-78)
70-25-13,14	(Nov-78)
70-25-15,16	(Nov-78)
70-25-17,18	(Nov-78)
70-25-19,20	(Nov-78)
70-25-21,22	(Nov-78)
70-25-23,24	(Jan-80)
70-25-25,26	(Nov-78)
70-25-27,28	(Nov-78)
70-25-29,30	(Nov-78)
70-25-31,32	(Nov-78)
70-25-33,34	(Nov-78)
70-25-35,36	(Nov-78)
70-25-37,38	(Nov-78)
70-26-1,2	(Nov-78)
70-26-3,4	(Nov-78)
70-26-5,6	(Nov-78)
70-26-7,8	(Nov-78)
70-26-9,10	(Nov-78)
70-26-11,12	(Nov-78)
70-26-13,14	(Nov-78)
70-26-15,16	(Nov-78)
70-26-17,18	(Nov-78)
70-26-19,20	(Nov-78)
70-26-21,22	(Nov-78)
70-26-23,24	(Jan-80)
70-26-25,26	(Nov-78)
70-26-27,28	(Nov-78)
70-26-29,30	(Nov-78)
70-26-31,32	(Nov-78)
70-30-1,2	(Nov-78)
70-35-1,2	(Jan-80)
70-35-3,4	(Nov-78)
70-35-5,6	(Jan-80)
70-35-7,8	(Nov-78)
70-35-9,10	(Nov-78)
70-35-11,12	(Jan-80)
70-35-13,14	(Nov-78)
70-35-15,16	(Nov-78)
70-35-17,18	(Nov-78)
70-35-19,20	(Nov-78)
Index 1,2	(Jan-80)
Index 3,4	(Jan-80)

*Vertical lines indicate pages included in this revision.*



**Brakes:**

Service . . . Power actuated, 4-wheel, inboard-mounted wet disk. Foot-operated by either right or left pedal. Parking . . . . . 10 x 1.5-inch (254 mm x 38 mm) expanding shoe on transmission output shaft. Adjustable, hand-operated, with warning light and buzzer.

Steering . . . . . Full power steering. Frame articulated 80 degrees by two hydraulic cylinders. Turning radius of 13 feet 10 inches (4.22 m). Turning clearance is 32 feet 9 inches (9.98 m) for 2 yd<sup>3</sup>.

**Hydraulic Systems:**

Loader functions . . . . . Independent engine-driven, vane pump delivers 44.5 gpm (168.4 Lpm) at 600 psi (42 kg/cm<sup>2</sup>) and 2,200 engine rpm. 2,500 psi (175.8 kg/cm<sup>2</sup>) relief valve pressure setting.

Control . . . . . Single-lever, dual hydraulic valve. Optional triple hydraulic valve for fork or multipurpose bucket.

Steering and brakes . . . . . Engine-drive, eight-piston, variable-displacement pump delivers 26 gpm (98.4 Lpm) at 2,200 engine rpm and 2,000 psi (140.6 kg/cm<sup>2</sup>). Maximum system pressure is 2,400 psi (169 kg/cm<sup>2</sup>).

**Hydraulic Cylinders:**

	<b>Bore</b>	<b>Stroke</b>
Boom, two . . .	5.25 in. (133 mm)	22.26 in. (565 mm)
Bucket, one . .	5.25 in. (133 mm)	27.22 in. (691 mm)

Cylinder rods . . . Ground, heat-treated, chrome-plated, polished  
 Boom and bucket cylinder rods 2.25 in. (57 mm) dia.

**Tires:**

14-24, 12-ply-rating, grader tread, G2  
 17.5-25, 12-ply-rating, loader tread, L2  
 17.5-25, 16-ply-rating, loader tread, L2  
 17.5-25, 12-ply-rating, rock tread, L3  
 23.1-26\*, 10-ply  
 \*Use with log loader

**Wheel Treads:**

Front and rear . . . . . 70 in. (1.78 m)

**Capacities:**

	<b>U.S.</b>	<b>Liters</b>
Cooling . . . . .	32 qt.	30.3
Fuel tank . . . . .	40 gal.	151.4
Crankcase with filter . . . . .	20 qt.	19.6
Crankcase without filter . . . . .	18 qt.	17.1
Transmission case and filters . . . . .	39 qt.	36.9
Front differential: No-Spin . . . . .	24 qt.	22.7
Rear differential . . . . .	25 qt.	23.7
Loader hydraulic sump . . . . .	48 qt.	45.4

**Additional Standard Equipment:**

- Adjustable cushioned seat
- Engine side shields
- Front fenders
- Gauges:
  - Transmission oil temperature
  - Transmission oil pressure
  - Fuel
  - Coolant temperature
  - Engine oil pressure
  - Electric hour meter
  - Voltmeter
  - Loader hydraulic system indicator
- Key switch
- Push button safety start
- Cigaret lighter
- Parking brake warning light and buzzer
- Transistorized voltage regulator
- Vandal protection
- Lights
- Horn
- Fuel filter
- Automatic return-to-dig
- Vertical muffler with rain cap
- Rear bottom guard
- Hand grips
- Fixed drawbar
- ROPS cab and seat belt
- Heater
- Antifreeze
- Aspirated air cleaner with integral pre-cleaner
- Cold weather starting aid

**Special Equipment:**

- Rear axle disconnect
- ROPS canopy and seat belt
- Instrument panel cover with lock
- Flashing and turning lights
- Reverse warning alarm
- Triple loader hydraulic valve
- Side counterweights
- Front bottom guard
- License plate bracket
- Defroster fan
- Engine coolant heater
- SMV emblem
- Automatic boom height control
- ROPS quiet cab
- Auxiliary cutting edges
- Suspension seat
- Sucker fan

### DIMENSIONS

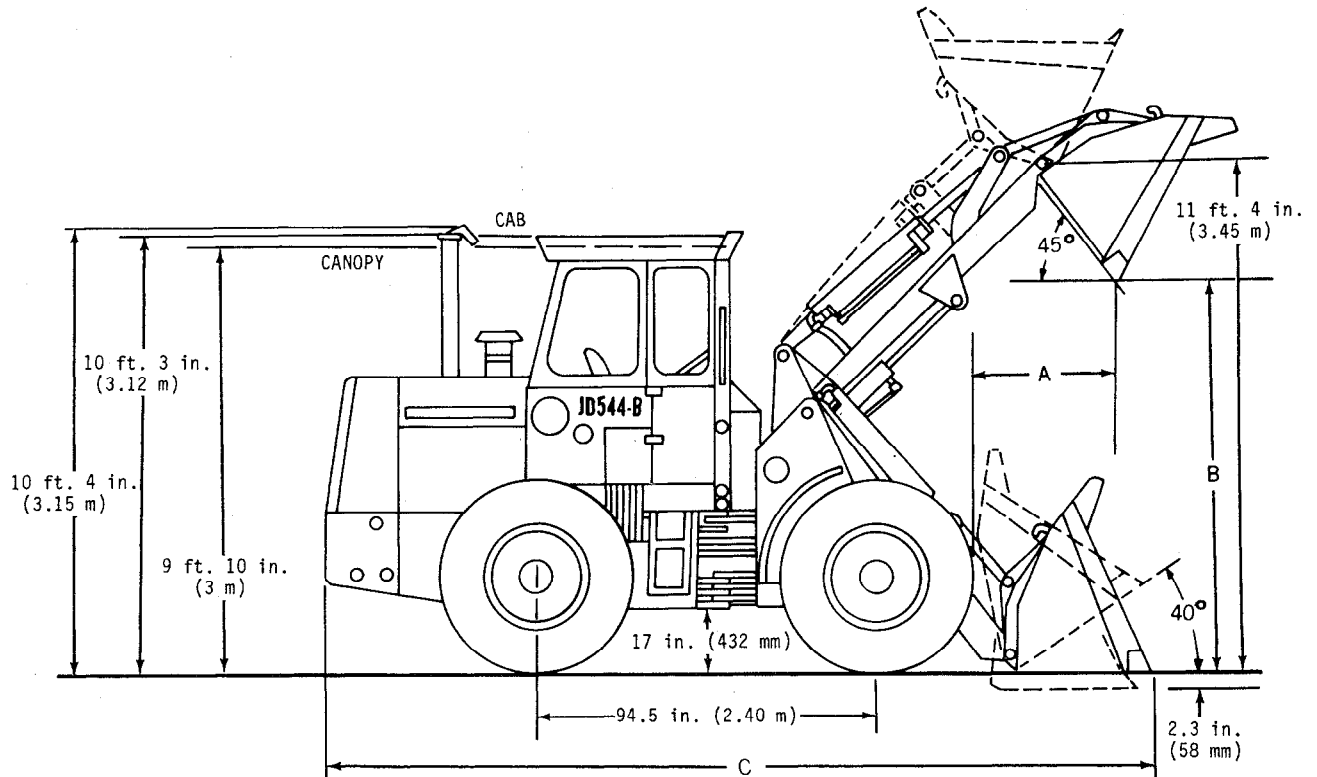

T63382N

BUCKET CAPACITIES	DIMENSIONS		
	A	B	C
1-3/4 cu. yd. bucket	35 in. (889 mm)	8 ft. 11 in. (2.72 m)	19 ft. 1 in. (5.82 m)
2 cu. yd. bucket	35.9 in. (912 mm)	8 ft. 10 in. (2.69 m)	19 ft. 2 in. (5.84 m)
3 cu. yd. bucket	42.5 in. (1079 mm)	8 ft. 4 in. (2.54 m)	20 ft. (6.10 m)
1-3/4 cu. yd. multipurpose	35.2 in. (894 mm)	8 ft. 3 in. (2.51 m)	20 ft. 1 in. (6.12 m)



## Group 10 PREDELIVERY, DELIVERY, AND AFTER-SALE SERVICES

### TEMPORARY STORAGE

After receiving your loader from the factory and before putting the machine into temporary storage perform the following checks.

For long term storage (over 30 days) information, consult your JD544-B Operator's Manual.

1. Check battery electrolyte level and charge the battery, if necessary.
2. Check coolant level in the radiator. The coolant should be maintained at a level midway between the radiator core and filler neck.
3. Fill the fuel tank.
4. Check crankcase oil level. Oil should be at top mark of dipstick after machine has been shut down for ten minutes.
5. Relieve hydraulic pressure by stopping engine, lowering bucket and operating steering wheel or control levers until system fails to respond.

### PREDELIVERY SERVICE

Because of the shipping factors involved, plus extra finishing touches that are necessary to promote customer satisfaction, proper predelivery service is of prime importance to the dealer and the customer.

If adjustments are required, procedures are found in the After-Sale section.

Use the following check list when preparing a loader for delivery to the customer.

#### 1. Pre-cleaner

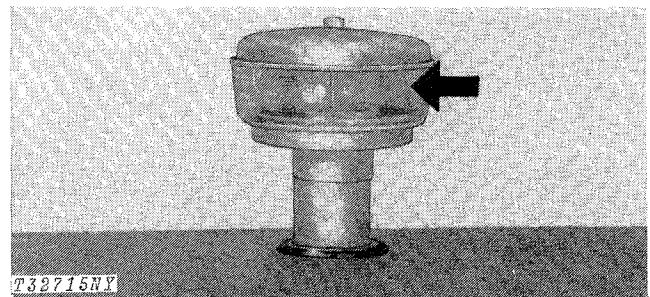

Fig. 1-Pre-cleaner

Check and clean pre-cleaner bowl.

Pre-cleaner checked and cleaned.

Yes No

## 2. Air Cleaner

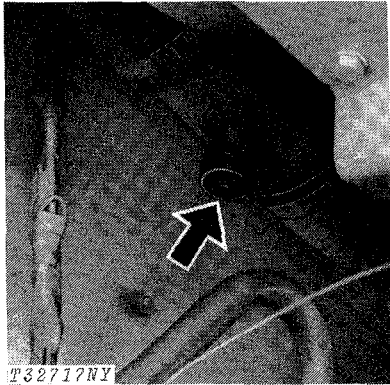
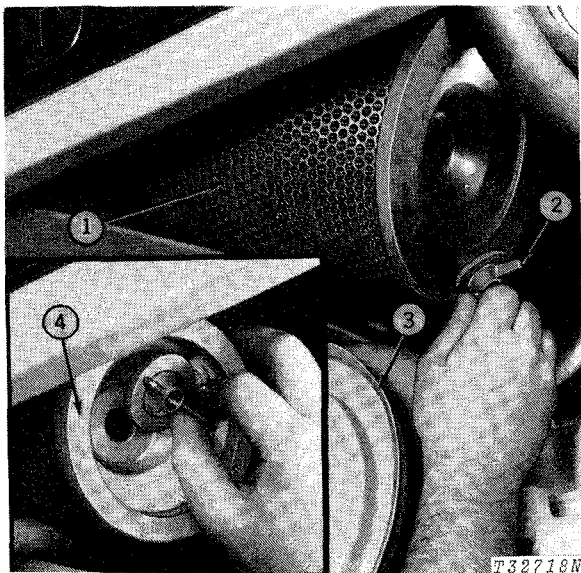

Fig. 2-Air Cleaner Restriction Indicator

Check air cleaner restriction indicator. If the indicator shows red, check and clean primary air filter element. Replace both primary and safety filter elements, if necessary.



- 1—Primary Filter Element
- 2—Wing Nut
- 3—Air Cleaner Cap
- 4—Safety Filter Element

Fig. 3-Air Cleaner

Air cleaner checked	Yes	No
Filters replaced	Yes	No

## 3. Fuel Filter

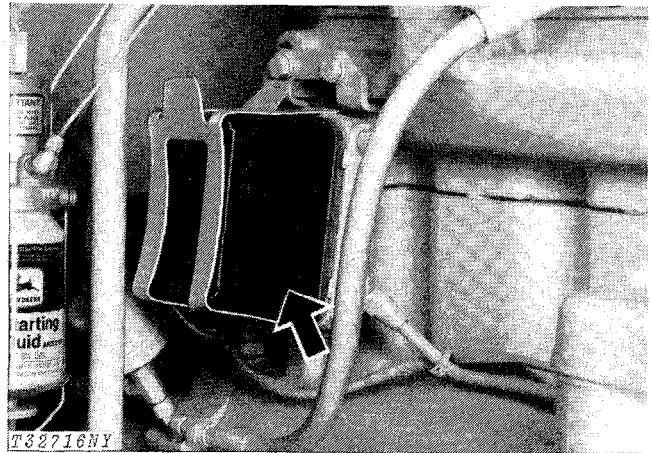

Fig. 4-Fuel Filter

Check fuel filter and drain any sediment that is present.

Sediment present in filter	Yes	No
----------------------------	-----	----

## 4. Air Intake Hoses

Check air intake hoses for loose or improper connections. Check air cleaner to exhaust stack aspirator hose for restrictions, damage or loose connections.

Hoses checked	Yes	No
---------------	-----	----

## 5. Batteries

Check battery electrolyte level. Batteries are located to the left of the operator and are accessible through the top door in the battery compartment. If distilled water is not available, use clean soft water. Avoid use of hard water. Remove foreign material from top of battery and coat terminals with petroleum jelly. Check vent holes in battery caps.

**IMPORTANT: Never add water to battery in freezing weather unless engine is to be run two or three hours to assure mixing of water and electrolyte.**

Punch date code on battery.

Water added	Yes	No
-------------	-----	----

## 6. Fuel Tank

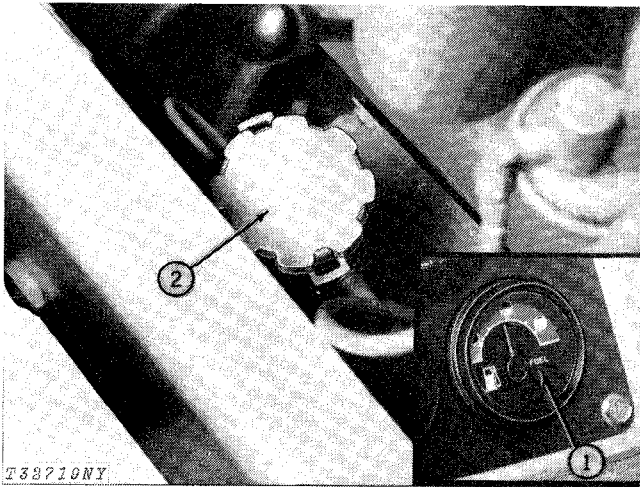

1—Fuel Gauge                      2—Fuel Tank Filler

Fig. 5-Fuel Tank Filler and Fuel Gauge

Check the fuel gauge. If fuel gauge indicates a low fuel supply, add sufficient fuel to fill the fuel tank. Fuel tank capacity is 40 U.S. gal. (151.42 L).

Fuel tank level              Full              1/2 Full              Empty

## 7. Radiator

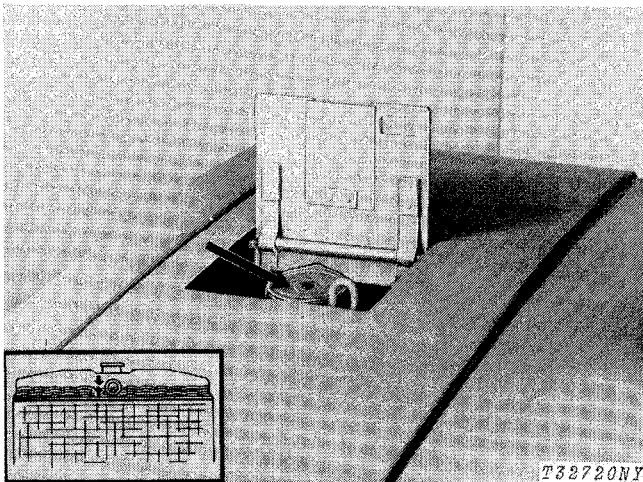

Fig. 6-Radiator Cap

Check coolant level in the radiator. Coolant level should be midway between the radiator core and filler neck.

Radiator coolant level checked              Yes      No  
 Coolant or anti-freeze added              Yes      No

## 8. Crankcase Oil Level

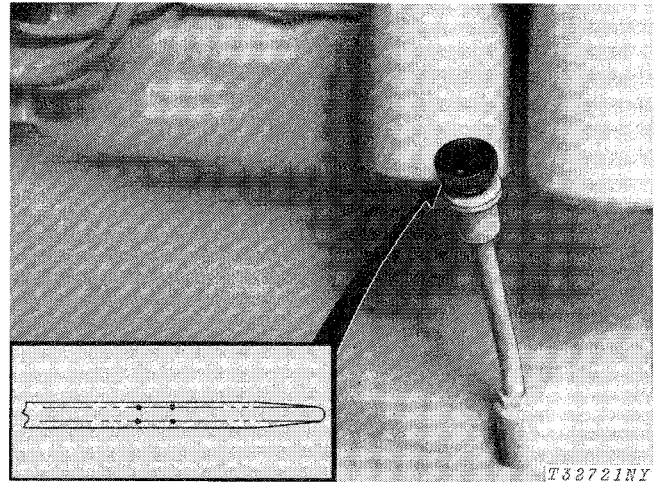

Fig. 7-Crankcase Dipstick

Check crankcase oil level with loader on level ground and the engine off. (Allow a minimum of 10 minutes for the oil to drain down before checking. The best time to check the oil is after an overnight shut down.) If oil level is at or below bottom mark on dipstick, add sufficient oil of the proper viscosity and type specified on page 10-15-2 to bring oil level up to the top mark on the dipstick. Do not operate the engine with oil level below the bottom mark or above the top mark on the dipstick.

**NOTE:** There is two quarts (1.89 L) difference between the bottom mark and the top mark on the dipstick.

Crankcase oil level checked              Yes      No  
 Oil added              Yes      No

### 9. Hydraulic Oil Level

Check loader hydraulic system oil level.

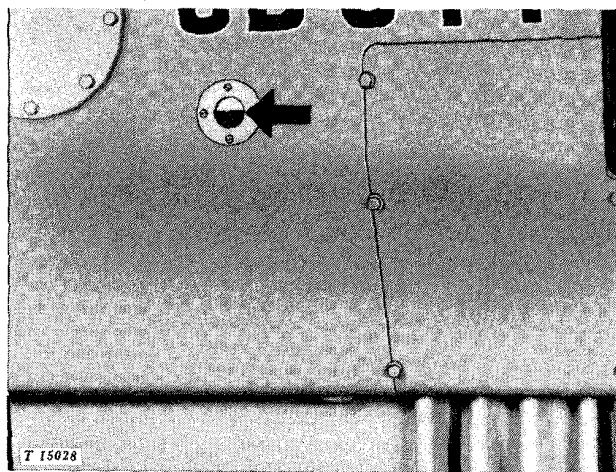

Fig. 8-Loader Hydraulic System Window Indicator

Check loader hydraulic system oil level with bucket resting on the ground. The oil level should be halfway up the window on the reservoir. If oil is low, add oil as specified on page 10-15-2 to bring level up to this point. The filler opening is located under the lid on top of the reservoir. Prevent dirt from entering system. Do not overfill.

Hydraulic system oil level checked Yes No  
 Oil added, if any \_\_\_\_\_qts. (L)

### 10. Transmission Oil Level

Check transmission oil level.

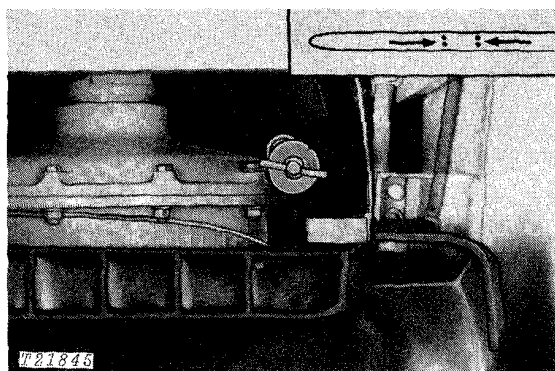

Fig. 9-Transmission Dipstick

A dipstick, located on the left side of the transmission is accessible by tilting the back of the seat forward. The correct oil level check is made with the dipstick fully inserted in dipstick tube.

Perform both of the following transmission oil level checks: (a) Before starting the engine check the oil level with dipstick. If the oil level is at or near the upper (FULL) mark, there is sufficient oil in the system to permit starting the engine. If oil level is low add hydraulic transmission fluid of the type specified on page 10-15-2. Replace dipstick and tighten finger tight.

(b) Operate loader until the transmission reaches normal operating temperature. Idle the engine and shift through all ranges slowly. This will fill all parts in the system with oil. Shift to neutral, apply the brakes and allow engine to idle. Check oil level again. It should now be at or above the lower (ADD) mark and not above the upper (FULL) mark on the dipstick. If not, add oil. Do not overfill.

Transmission oil level checked Yes No  
 Transmission oil added, if any \_\_\_\_\_qts. (L)

### 11. Front and Rear Differential Oil Level

Check front and rear differential oil level.

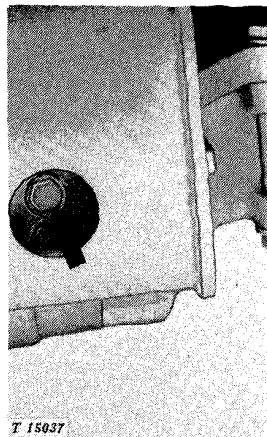

Fig. 10-Front Differential Check Plug

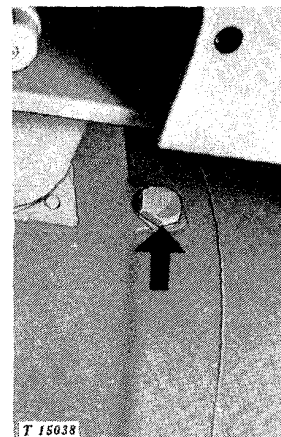

Fig. 11-Rear Differential Check Plug

Check oil level at oil level - filler plug on the side of the differential housings. Oil must be cold and loader must be on level ground. The oil level should be up to the plug. Add John Deere HY-GARD Transmission and Hydraulic Oil or an equivalent, if necessary.

Differential oil levels checked Yes No  
 Oil added, if any \_\_\_\_\_qts. (L)

## 12. Alternator-Fan Belt Tension

Check belt tension. Adjust to proper tension.

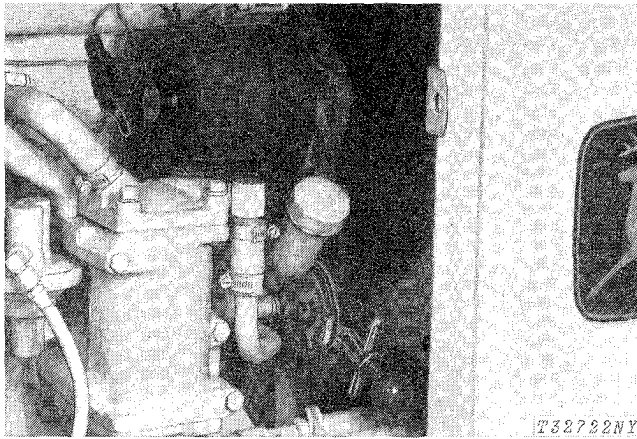

Fig. 12-Alternator-Fan Belt Adjustment

**IMPORTANT: Do not pry on the rear alternator housing as this may damage the alternator. If belt needs to be tightened use the following procedure.**

Adjust belt tension by loosening the alternator bracket and adjusting cap screws and apply outward pressure to the front alternator frame. Using a belt tension gauge, a force of 20 pounds (9 kg) midway between the pulleys should deflect the belt 0.75 inch (19 mm).

More consistent belt tension will result and the belts will last longer if the tension is set with a strand tension gauge. When a strand tension gauge is used, the initial reading should be 100 to 110 pounds (45.4 to 49.9 kg) strand tension. After 3 minutes of operation recheck the strand tension. The gauge should read a minimum of 80 pounds (36.3 kg) strand tension.

**NOTE: Recheck belt tension after adjustment. DO NOT OVERTIGHTEN.**

Alternator-fan belt tension \_\_\_\_\_lb. (kg) tension  
 \_\_\_\_\_in. (mm) flex

## 13. Check Engine Speeds

Warm up engine and attach a tachometer to the engine tachometer drive to check engine speeds.

No-load, fast idle speed should be 2375-2425 rpm. Slow idle should be 700 rpm.

If engine speeds need adjustment, see page 10-10-24.

Engine speeds checked Yes No

Litho in U.S.A.

## 14. Check Lubrication

The loader was checked and lubricated before it left the factory. However, to insure customer satisfaction, check each lubrication point shown in the following pages. Lubricate with several strokes, if necessary.

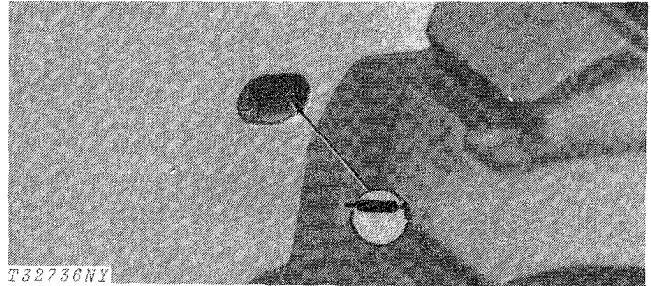

Fig. 13-Steering Cylinder Rear Pivot Pins (2 Points)

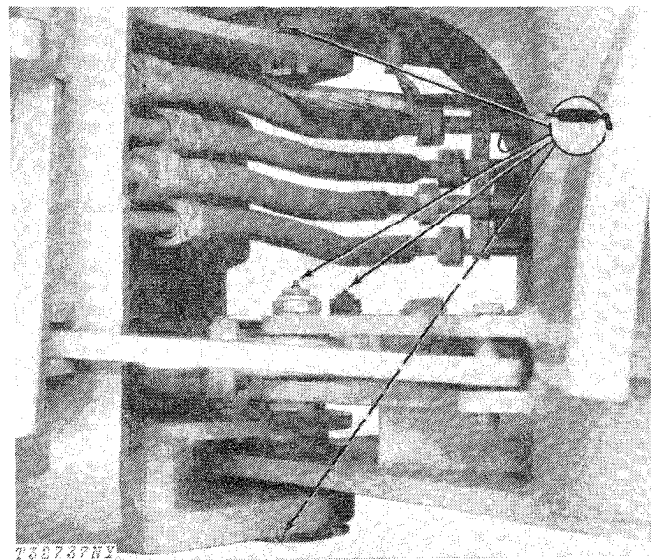

Fig. 14-Steering Cylinder Front Pivot Pins (2 Points) and Frame Hinge Pivots (2 Points)

Lubricant required Yes No

Lubricate all pivot points in the linkage from the control lever to the control valves with engine oil.

Lubricant required Yes No

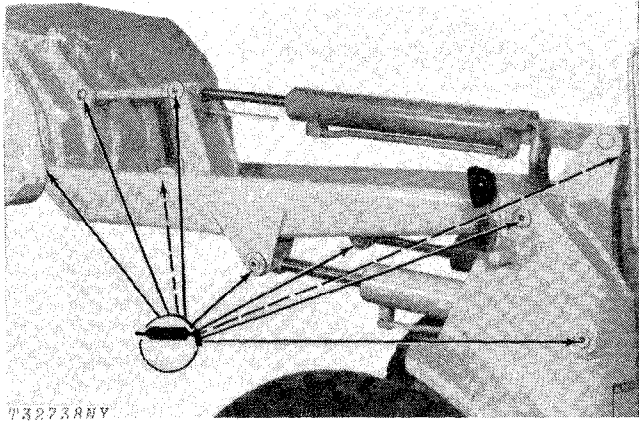

Fig. 15-Loader Boom and Bucket Cylinders and Pivots (12 Points)

Lubricant required Yes No

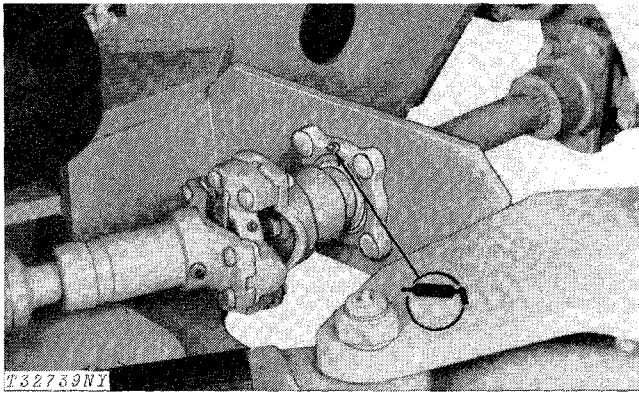

Fig. 16-Front Drive Shaft Support Bearing (1 Point)

Lubricant required Yes No

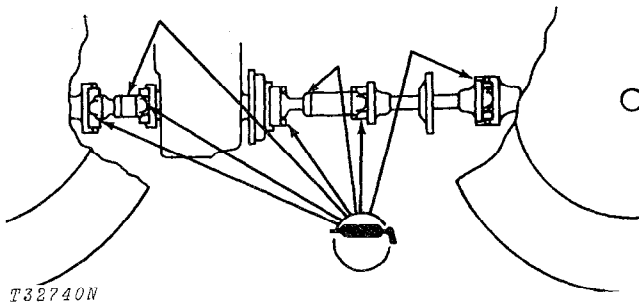

Fig. 17-Transmission-to-Differential Drive Lines (7 Points)

Lubricant required Yes No

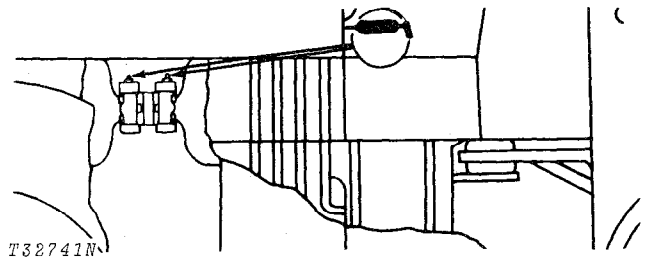

Fig. 18-Engine-to-Transmission Universal Joint (2 Points)

Lubricant required Yes No

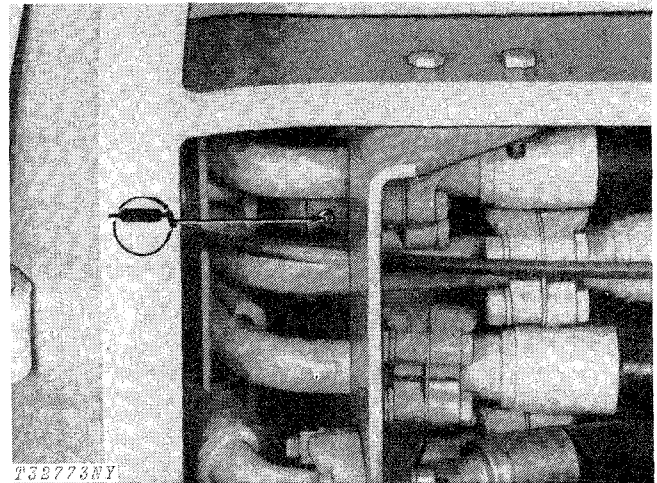

Fig. 19-Shift Control Bell Crank Fitting (1 Point)

Lubricant required Yes No

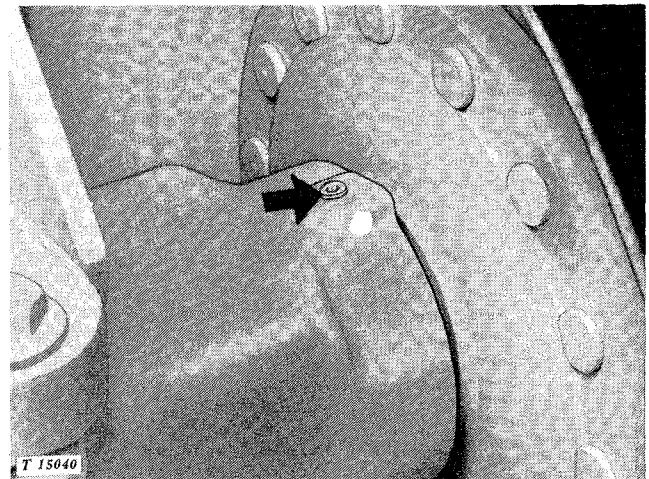

Fig. 20-Axle Bearing Plug (Front Shown) (4 Points)

If lubrication is required, remove pipe plug in each wheel and install grease fittings.

Lubricant required Yes No

### 15. Indicator Lights and Gauges

When operating the loader, check the following gauges for correct operation.

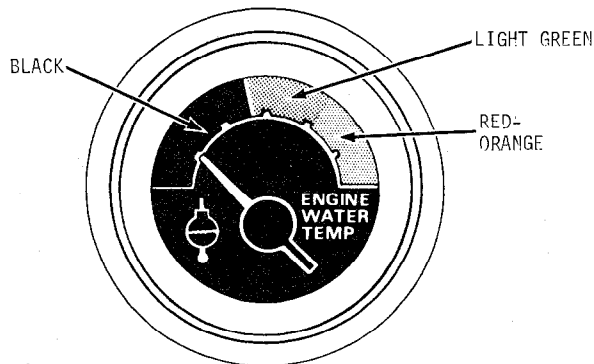

T50859

Fig. 21-Engine Coolant Temperature Gauge

Normal operating range is indicated by the light green area on the gauge face—135°F to 224°F (57°C to 107°C).

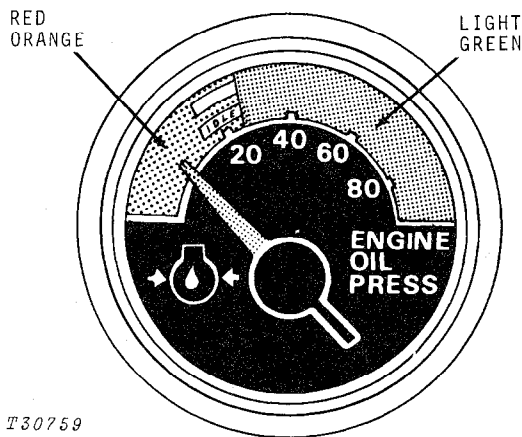

T30759

Fig. 22-Engine Oil Pressure Gauge

Normal operating range is indicated by the green zone on the gauge face.

If engine oil pressure indicator hand is not in the green zone, stop engine and check oil level.

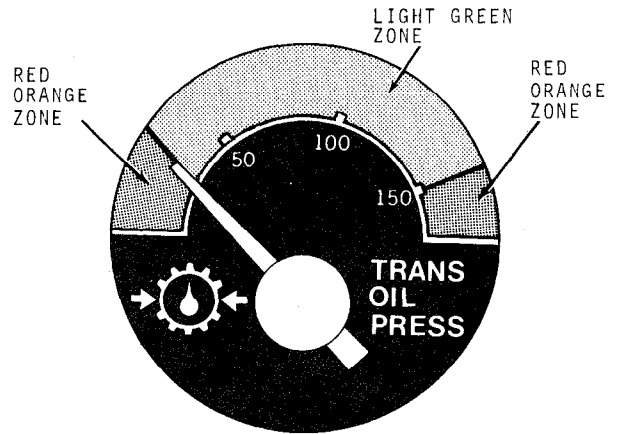

T34531N

Fig. 23-Transmission Oil Pressure Gauge

Normal operating range is indicated by the green zone on the gauge face.

If the transmission oil pressure indicator hand is not in the green zone, stop engine and determine the cause.

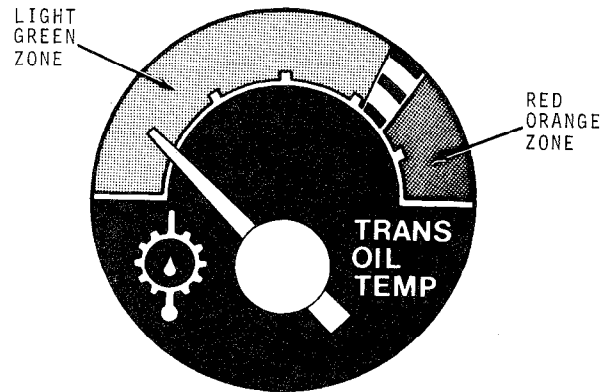

T34530N

Fig. 24-Transmission Oil Temperature Gauge

Normal operating range is indicated by the green zone on the gauge face.

If the transmission oil temperature indicator hand is not in the green zone, stop engine and check oil level.

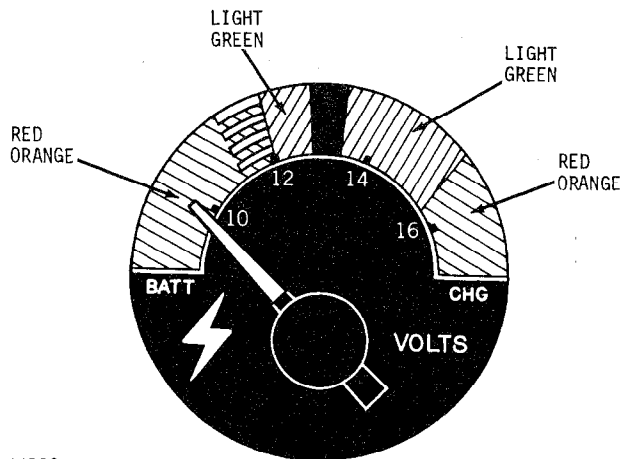

T44558

Fig. 25-Voltmeter

Normal operating range is indicated by the right-hand green zone.

If the voltmeter indicator hand is not in the right-hand green zone, troubleshoot the electrical system.

All gauges operational Yes No

## 16. Light Operation

Check light operation.

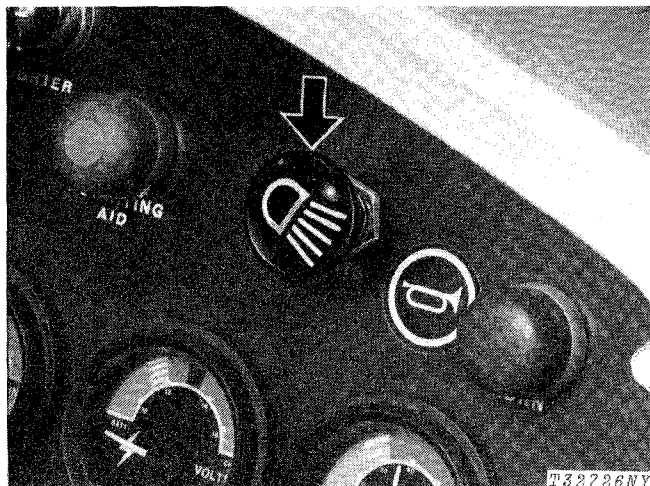

Fig. 26-Light Switch

All lights are controlled by two switches. The headlights, taillights and work lights are controlled by a push-pull light switch located on the right-hand dash panel. The flashing warning lights are controlled by a lever mounted on the steering column.

The light switch mounted on the right-hand dash panel has three positions:

- 1 - Completely In—All lights are off.
- 2 - First Position (Half-way Out)—Headlights and taillights are on.
- 3 - Second Position (Completely Out)—Work lights, headlights and taillights are on.

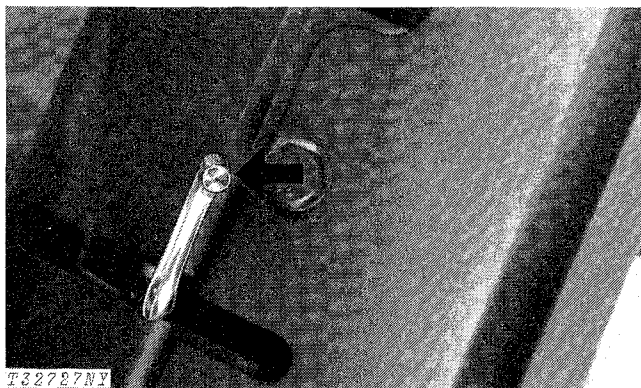

Fig. 27-Turn Signal/Warning Light Switch

The turn signal/warning light switch is used to indicate a right or left turn as well as to operate the flashing lights when in a fully-clockwise position.

All lights operational Yes No

## 17. Heater/Air Conditioner Operation

If the loader is equipped with a heater, check the heater operation.

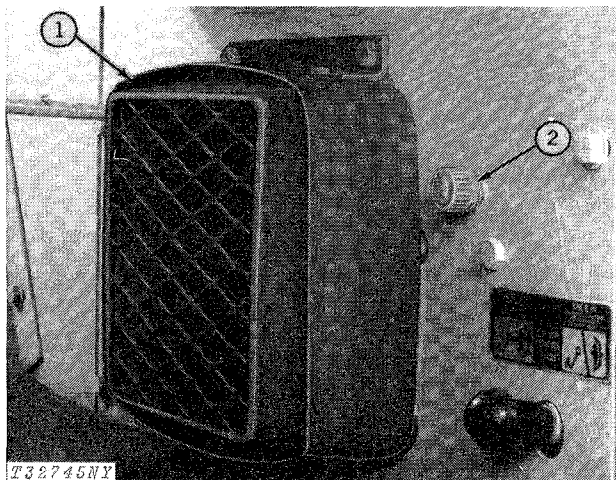

1—Heater

2—Heater Control

Fig. 28-Cab Heater

If the loader is equipped with an air conditioner, check the air conditioner operation.

**NOTE:** Check for proper refrigerant charge before using air conditioner.

**NOTE:** Ambient air temperature must be at least 60°F (16°C).

With key switch "on", operate blower knob in all positions. Observe fan speeds and air volume from air ducts.

With key and blower switches "on", turn temperature switch toward maximum cooling and listen for audible "click" from compressor clutch. Turn heater valve to closed position.

With blower switch at "high speed" and air conditioner switch at maximum cooling, operate engine at 2000 rpm.

After 10 minutes, observe sight glass for bubbles.

**NOTE:** Bubbles may be present immediately after compressor cycles "on". If occasional bubbles or a constant stream of bubbles are observed under any other condition, refer to Operational Diagnostic Chart, p. 70-16-7.

Check temperature of discharge air from air ducts. Hold thermometer in air duct until lowest reading is obtained.

- a) If ambient temperature is above 80° (27°C), the duct air temperature must be 25 to 30°F (14 to 17°C) below ambient temperature.
- b) If ambient temperature is below 80°F (27°C), the duct air temperature must be less than 50°F (10°C).

If unit does not operate as described above, refer to Diagnostic Chart, page 70-16-7.

Heater operation checked	Yes	No
Air conditioner operation checked	Yes	No

## 18. Windshield Wiper Operation

If the loader is equipped with a cab, check the operation of the windshield wipers.

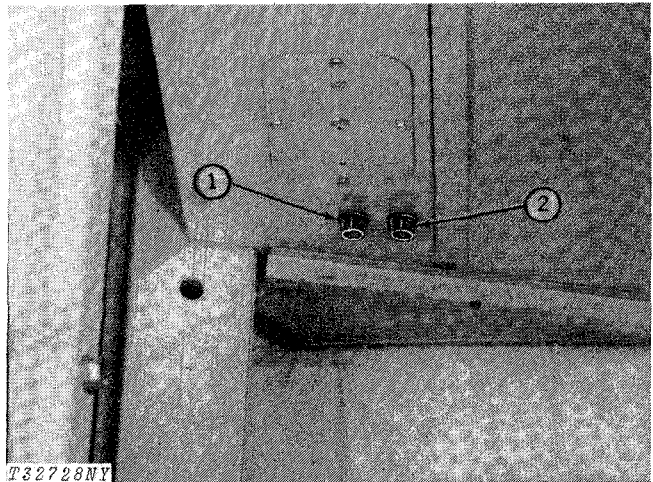

1—Front Wiper Control

2—Rear Wiper Control

Fig. 29-Windshield Wipers

Windshield wipers operational	Yes	No
-------------------------------	-----	----

## 19. Check No-Spin Differential Operation

Check the operation of the no-spin differential. The front drive wheels should both turn at the same rate, providing full power to each wheel under varying tractive conditions.

However, during turns or when operating on uneven terrain, an overriding clutch within the differential automatically unlocks, providing the necessary differential action.

No-spin differential operational	Yes	No
----------------------------------	-----	----

## 20. Steering

Start the engine and operate the steering wheel. Steering should be free and easy with engine running. If steering is difficult, see Section 70, Group 25 for testing procedures.

Steering operational	Yes	No
----------------------	-----	----

## 21. Check Transmission Operation

The loader is equipped with a power shift transmission. The power shift transmission has two forward speeds and one reverse speed range. The transmission may be locked in neutral.

Check the transmission operation.

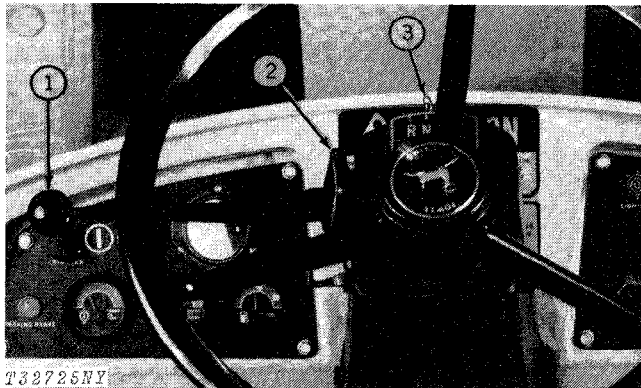

- 1—Shift Lever
- 2—Neutral Latch
- 3—Range Indicator

Fig. 30-Transmission Operation

Shift transmission through all ranges. If transmission does not respond see Section 40 for repair.

Transmission operational Yes No

## 22. Hydraulic Brakes

Check brake operation. Pedal action should be firm—pedals should not bottom out or feel spongy.

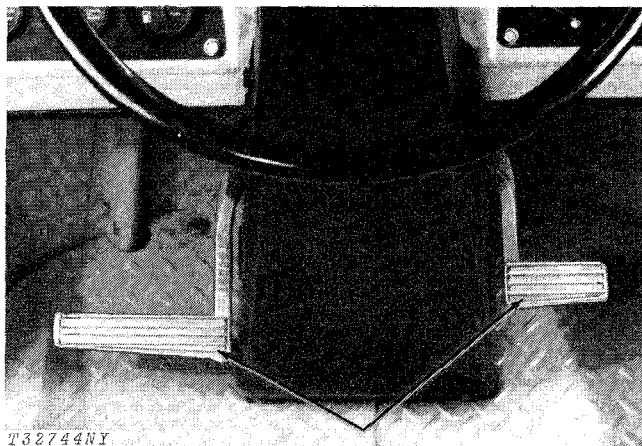

Fig. 31-Brake Pedals

Brakes operational Yes No

## 23. Clutch Control

Check the clutch control operation.

**CAUTION:** The clutch control knob should be pushed in (KNOB IN position) when transporting the loader. The clutch control knob should be pulled out (KNOB OUT position) during loading and dumping operations only. The clutch control knob should be pushed in (KNOB IN position) before stopping on steep inclines. The loader clutch control knob can be pushed in (KNOB IN position) while the brakes are applied.

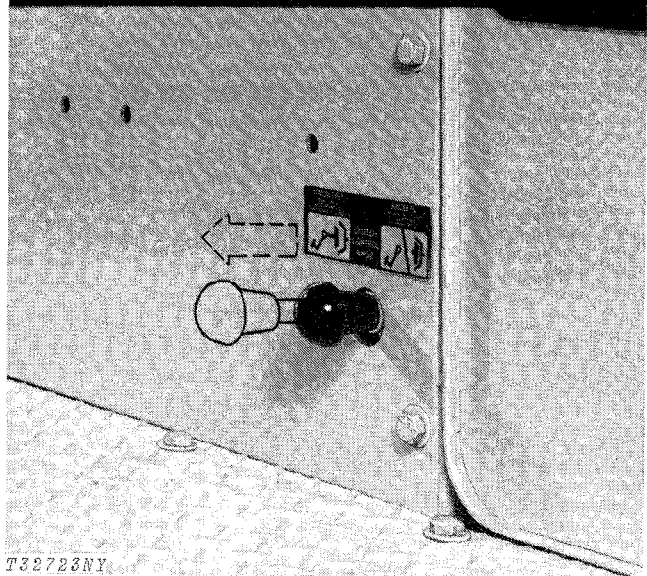
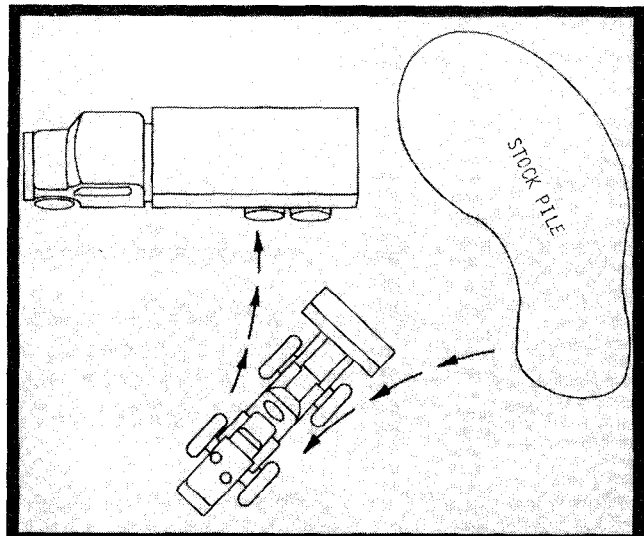

Fig. 32-Transmission Clutches Disengaged By Brake Pedal

The loader transmission is equipped with a clutch control valve. This valve is operated by a knob located below the seat. With the knob pulled out, the transmission clutches are disengaged when the brake pedal is depressed. When the knob is in this position, the operator, with a full bucket, can approach a truck with the engine at full throttle, depress the brake pedal which disengages the transmission - and obtain maximum hydraulic speed. The unit will not creep forward with the brakes applied.

After the bucket has been emptied into the truck, the operator shifts the loader into reverse and releases the brakes. When the brake line pressure drops, the transmission clutches re-engage in the normal manner.

The clutch control valve enables the operator to speed up loading and dumping operations.

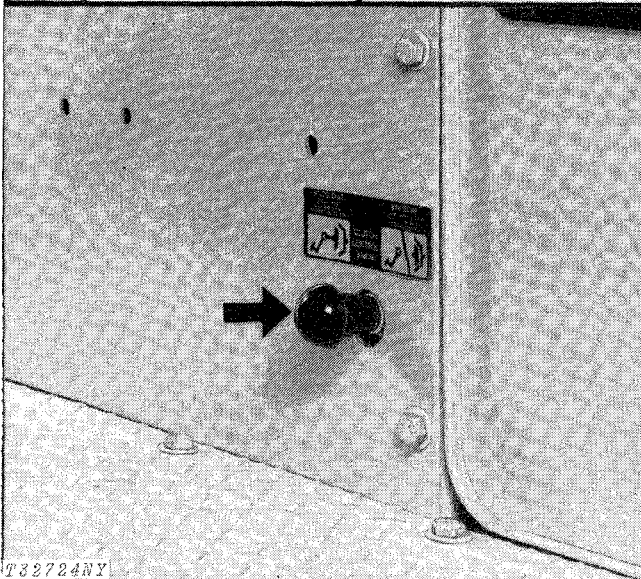
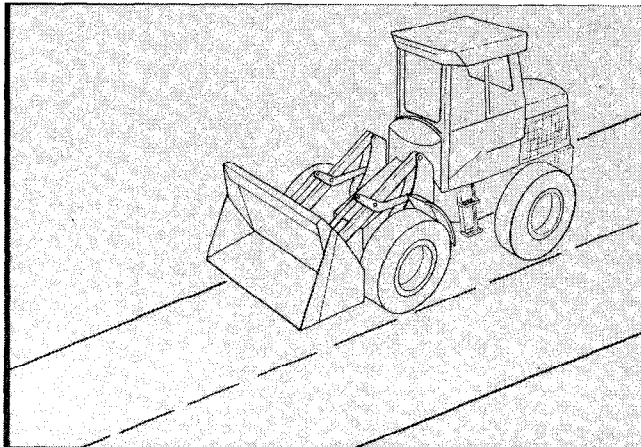

Fig. 33-Transmission Clutches Not Disengaged by Brake Pedal

Clutch control operational Yes No

## 24. Rear Axle Disconnect

Check the loader rear axle disconnect operation.

Push down on lever located behind the seat to engage rear axle. Pull up to disengage rear axle. This option assures maximum transport speeds.

**IMPORTANT: Do not engage or disengage the rear axle with the loader in motion. Pivot the loader frame slowly from side to side while engaging or disengaging the axle.**

Rear axle disconnect operational Yes No

## 25. Tire Pressure

Check the air pressure in all the tires with an accurate gauge having 1-pound (0.45 kg) graduations.

**IMPORTANT: All tires must be inflated to the same pressure.**

Adjust pressure in tires to the following specifications.

Tire Size	Ply Rating	Inflation Pressures Minimum	Inflation Pressures Normal
14.00-24	12	50 psi (3.87 kg/cm <sup>2</sup> )	60 psi (4.22 kg/cm <sup>2</sup> )
17.5-25	12	40 psi (2.81 kg/cm <sup>2</sup> )	50 psi (3.87 kg/cm <sup>2</sup> )
23.1-26*	10	20 psi (1.5 kg/cm <sup>2</sup> )	

\*Use with log loader or tree shear only.

Tire pressure checked Yes No

## 26. Loader Boom and Bucket Operation

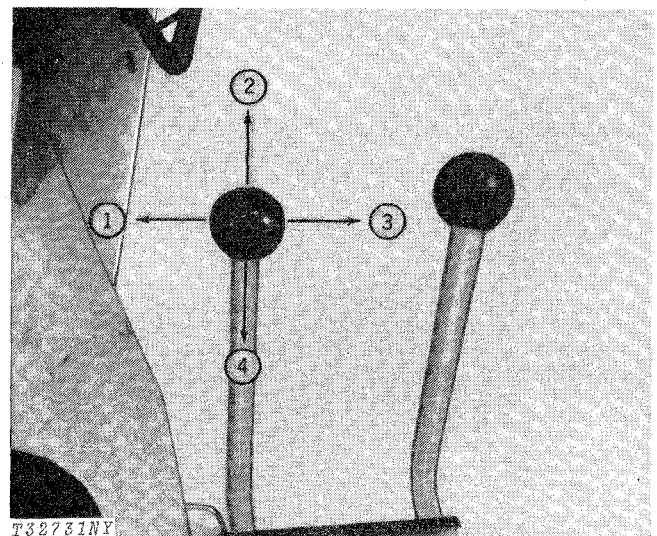

1—Retract Bucket      3—Dump Bucket  
 2—Lower Boom      4—Raise Boom

Fig. 34-Boom and Bucket Control Lever



## 28. Circuit Breakers and Fuses

Check all circuit breakers and fuses. Replace if necessary.

The electrical system and lights are each protected by two 20-amp circuit breakers located behind the right-hand instrument panel and fuses located under the left-hand instrument panel (Fig. 37).

The circuit breaker will open when a current of 40 amps is applied for one minute. If this happens, turn off the key switch and the circuit breakers will reset themselves in 35 seconds.

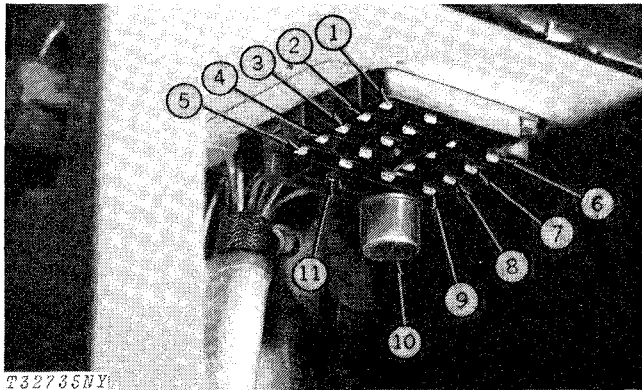

- |                           |                        |
|---------------------------|------------------------|
| 1—Injection Pump (10 amp) | 7—Cab Load (30 amp)    |
| 2—Starting Aid (15 amp)   | 8—Brake Light (10 amp) |
| 3—Horn (30 amp)           | 9—Turn Signal (10 amp) |
| 4—Taillight (5 amp)       | 10—Turn Flasher        |
| 5—Back-Up Alarm (30 amp)  | 11—Alternator (5 amp)  |
| 6—Heater (5 amp)          |                        |

Fig. 37-Fuse Identification and Size

### Cab Fuses

The front windshield wiper is protected by a 6 amp circuit breaker and the rear windshield wiper and defroster fan are protected by 5 amp fuses.

Fuses and circuit breakers checked	Yes	No
Fuses replaced, if necessary	Yes	No

## 29. Bleeding The Fuel System

After removing any components of the fuel system, air should be removed by bleeding. Bleeding is also necessary whenever the fuel tank has been emptied.

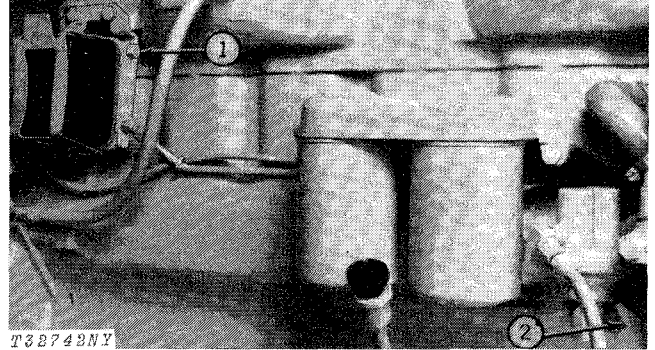

- 1—Filter Bleed Plug                      2—Priming Lever

Fig. 38-Bleeding Fuel System

Loosen the filter bleed plug (1, Fig. 38). Pump the primer lever on the fuel pump (2) until fuel, free of air bubbles, flows from the bleed plug. Tighten the bleed plug and leave the primer lever in the down position.

*NOTE: If the primer does not pump fuel and no resistance is felt at the upper portion of the lever stroke, turn the engine with the starter to change the fuel pump cam position.*

Fuel system bled	Yes	No
------------------	-----	----

## 30. Parking Brake

Check the parking brake for proper adjustment. Adjust, if necessary.

Forty-five pounds (20 kg) of force is required at top of handle to activate parking brake. See page 10-10-26 to adjust parking brake.

Parking brake adjusted	Yes	No
------------------------	-----	----

### 31. Wheel Retaining Cap Screws

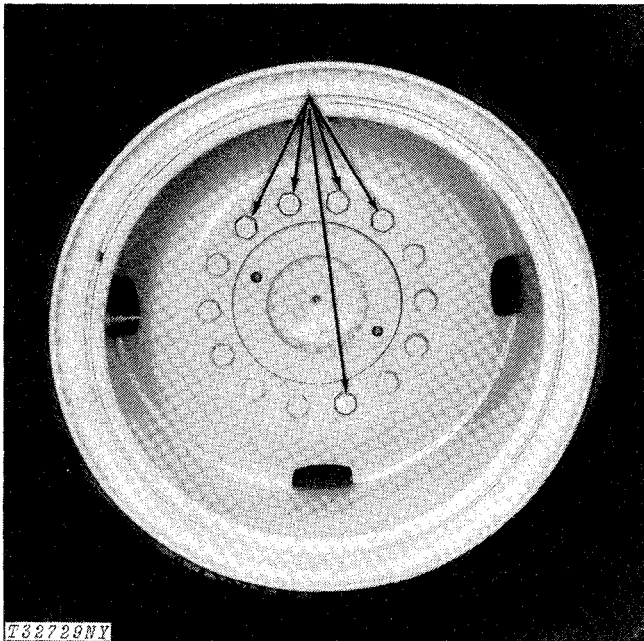

Fig. 39-Wheel Retaining Cap Screws

Check all wheel retainer cap screw torque. Tighten wheel retaining cap screws to 300 lb-ft (41.48 kg/m).

Wheel retaining cap screws tightened  Yes  No

### 32. Accessible Hardware Torque Values

Check all accessible bolts and nuts for proper tightness. If hardware seems loose, tighten it to the proper torque. The table below gives correct torque values for various bolts and cap screws. Most hardware used is high-strength (note dashes on hex. heads).

RECOMMENDED TORQUE IN LB-FT   Kg-m   COARSE AND FINE THREADS			
	B	D	F
Bolt Diameter	Plain Head	Three Dashes	Six Dashes
1/4	Not used	10   1.4	14   1.9
5/16	Not used	20   2.8	30   4.1
3/8	Not used	35   4.8	50   6.9
7/16	35   4.8	55   7.6	80   11.1
1/2	55   7.6	85   11.8	120   16.6
9/16	75   10.4	130   18.0	175   24.2
5/8	105   14.5	170   23.5	240   33.2
3/4	185   25.6	300   41.5	425   58.8
7/8	160   22.1	445   61.5	685   94.7
1	250   34.6	670   92.5	1030   142.4
1-1/8	330   45.6	910   125.8	1460   201.9
1-1/4	480   66.4	1250   172.8	2060   284.8

T30882

Fig. 40-Torque Chart

The types of bolts and cap screws are identified by head markings as follows;

Plain Head: regular machine bolts and cap screws.

3-Dash Head: tempered steel high-strength bolts and cap screws.

6-Dash Head: tempered steel extra high-strength bolts and cap screws.

Machine bolts and cap screws 7/8-inch and larger are sometimes formed hot rather than cold, which accounts for the lower torque.

All accessible hardware torqued  Yes  No

### 33. Final Check

The final predelivery procedure is overall clean-up of the loader. Make it LOOK like a new loader with the proper touch-up of chipped paint and a good wash job. Deliver to the customer a new looking loader.

## DELIVERY SERVICE

A thorough discussion of the operation and service of this new loader at the time of delivery helps to assure complete customer satisfaction. Proper delivery should be an important phase of a dealer's program. A portion of the John Deere Delivery Receipt emphasizes the importance of proper delivery service.

Many complaints arise because the owner was not shown how to operate and service the new loader properly. Devote enough time, at the customer's convenience, to introduce the owner to the new loader. Explain how to operate and service it.

The following procedure is recommended before the service technician and owner complete the delivery acknowledgments portion of the Delivery Receipt.

Using the operator's manual as a guide, be sure the owner understands these points thoroughly:

1. The importance of safety.
2. The importance of lubrication and periodic services.
3. The importance of the break-in period.
4. Controls and instruments.
5. How to start and stop the engine.
6. All functions of the hydraulic system.

After explaining and demonstrating the above features, have the owner sign the Delivery Receipt and give the owner the operator's manual.

## AFTER-SALE INSPECTION

The purchaser of a new John Deere loader is entitled to a free inspection at some mutually agreeable time within the warranty period after the equipment has been "run in," usually after 50 to 100 hours of loader operation. The terms of this after-sale inspection are outlined on the customer's John Deere Delivery Receipt.

This inspection is to make sure that the customer is receiving satisfactory performance from the loader. At the same time, the inspection should reveal whether or not the loader is being operated, lubricated, and serviced properly.

If the recommended after-sale service inspection is followed, the dealer can eliminate a needless volume of service work by preventing minor irregularities from developing into serious problems later on. This will promote strong dealer-customer relations and present the dealer an opportunity to answer questions that may have arisen during the first few days of operation.

During this inspection service, the dealer has the opportunity to promote the possible sale of other new equipment.

Check operation of all controls and instruments for freedom of movement and correct operation.

## 1. Engine Crankcase Oil and Filters

**NOTE:** Check with the customer if oil has been changed and filters replaced before performing this service.

Normal sequence of service is as follows:

- Oil change - After first 100 hours.
  - Every 200 hours thereafter.
- Filter change - After first 100 hours.
  - Every 200 hours thereafter.

If changed, record information below:

Approximate hours at change \_\_\_\_\_

If not, change as follows:

Drain crankcase when the oil is hot.

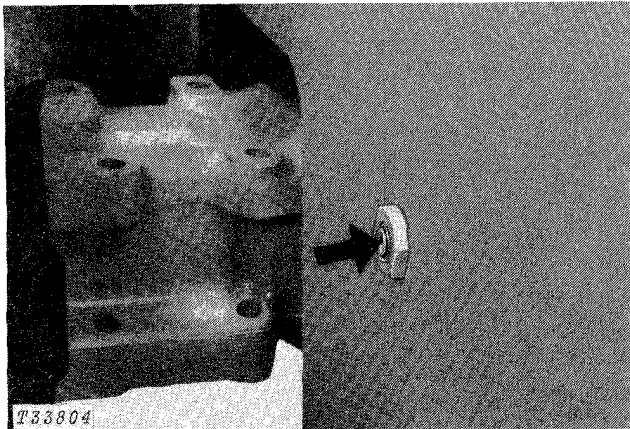

Fig. 41-Crankcase Drain Plug

Remove the crankcase drain plug. Plug is located behind left-hand rear wheel. Allow all oil to drain.

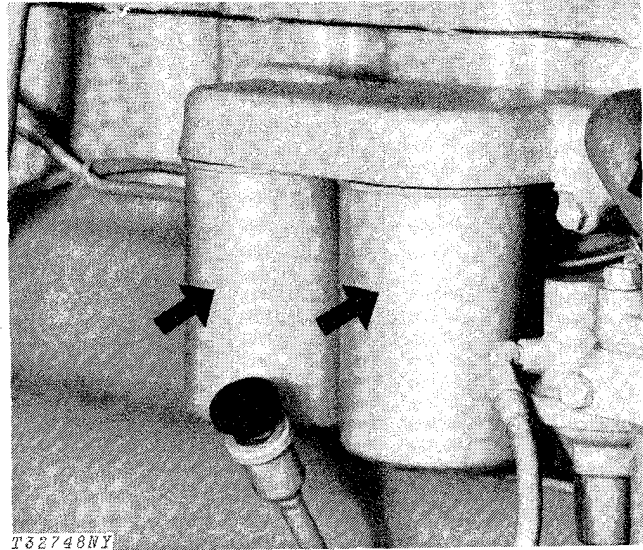
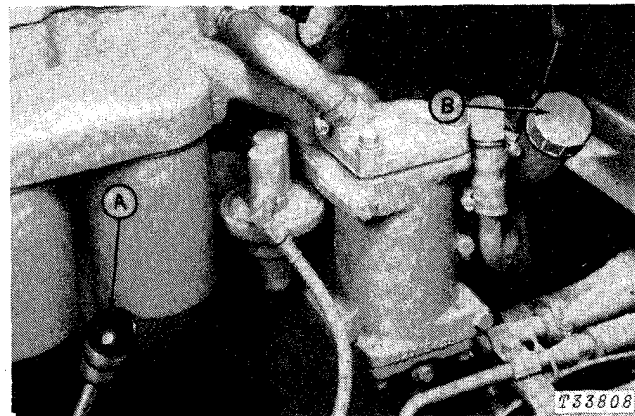

Fig. 42-Engine Crankcase Filters

Leave drain plug out and release the crankcase oil filters. Thoroughly clean filter mounting surface and install new elements. Make sure new sealing ring is inserted in end of element. Apply a film of oil to the sealing ring. Turn element until sealing ring touches mounting pad, then turn an additional 1/2 to 3/4 turn. Do not overtighten.

**IMPORTANT:** The filter elements have a special by-pass valve. Use only a John Deere element.

Install drain plug and add 20 qts. (19 L) of John Deere TORQ-GARD SUPREME Oil or an equivalent.



A—Crankcase Dipstick      B—Oil Filler Cap

Fig. 43-Checking Crankcase Oil Level

With oil in crankcase, start engine and check for leaks around filter elements. Retighten if necessary, but do not overtighten.

Check crankcase oil level with loader on level ground and the engine off. Allow a minimum of 10 minutes for the oil to drain down before checking. Do not operate the engine with oil level below the bottom mark or above the top mark on the dipstick.

*NOTE: There is two quarts (1.9 L) difference between the bottom mark and the top mark on the dipstick.*

Crankcase oil changed	Yes	No
Oil filters changed	Yes	No

## 2. Hydraulic Reservoir Oil and Filters

*NOTE: Before checking oil level find out if customer has changed filter elements (first 50 hours service).*

If changed at an earlier date, record information below:

Approximate hours at change \_\_\_\_\_

If not, change as follows:

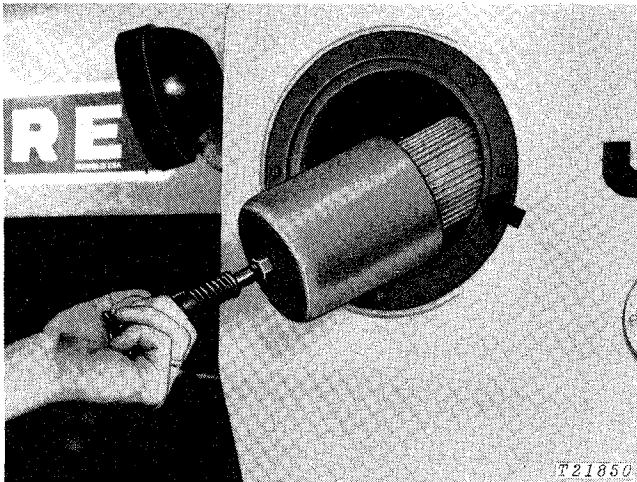
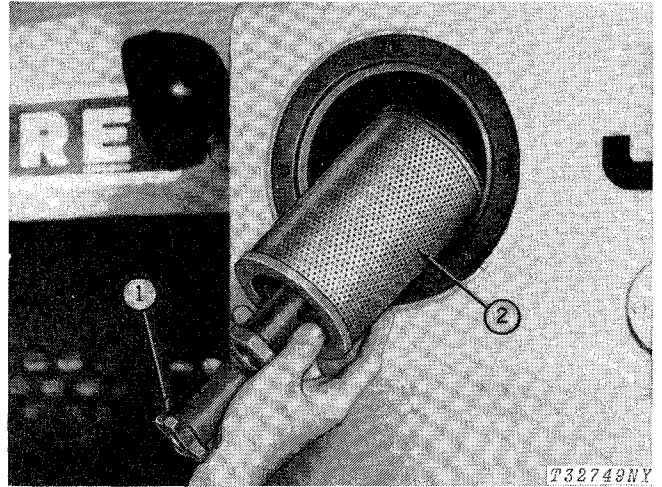

Fig. 44-Suction Filter

Remove reservoir filler cap to relieve pressure. Remove reservoir cover. Remove the wire mesh filter assembly from the reservoir by pulling the spring latch down. Remove the filter from the filter can and wash it in diesel fuel. Blow out the impurities with compressed air. Replace the filter assembly in the reservoir. Make sure the filter assembly is secure.



1—Filter Latch

2—Return Filter

Fig. 45-Return Filter

The return filter is located to the right of the suction filter. Remove by unscrewing the filter latch. After filter is removed from reservoir, remove snap ring to remove filter from center tube.

When installing new filter, be sure it is sealed properly and latch is in socket.

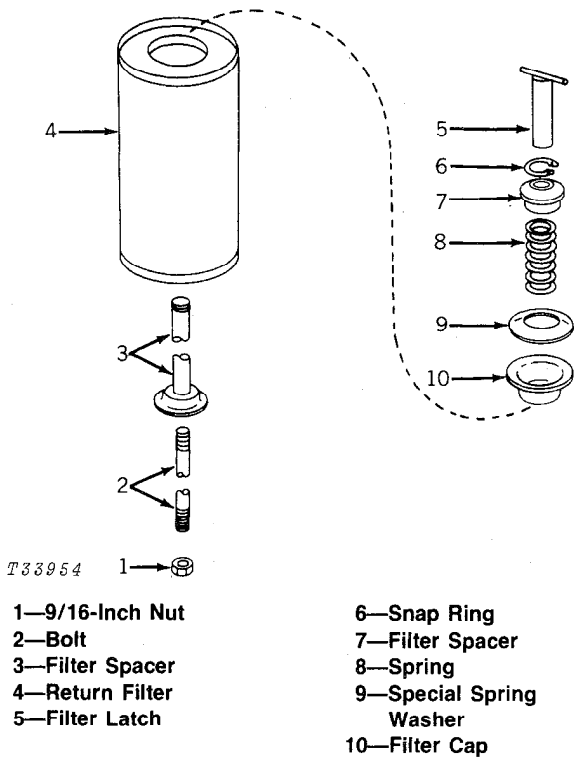

Fig. 46-Return Filter Components

Turn latch until tight to insure proper filter engagement. Turn filter latch until a noticeable change in effort is noted, then hand turn the latch a minimum of 1/2 turn. Additional hand tightening of the latch will not damage the filter.

Check loader hydraulic system oil level.

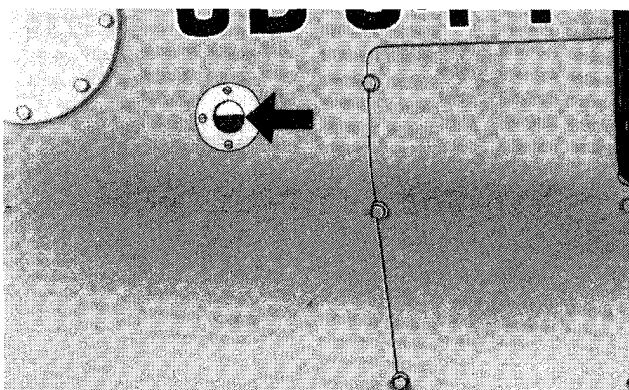

Fig. 47-Loader Hydraulic System Window Indicator

Check loader hydraulic system oil level with bucket level and resting on the ground. The oil level should be half-way up the window on the reservoir. If oil is low, add enough John Deere HY-GARD Oil to bring level up to this point. The filler opening is located under the lid on top of the reservoir. Prevent dirt from entering system. Do not overfill.

Hydraulic system oil  
 filter changed  
 Oil added, if any

Yes No  
 \_\_\_\_\_ qts. (L)

### 3. Steering and Transmission Oil Filters

*NOTE: Before checking oil level find out if customer has changed filter elements (first 100 hours service).*

If changed at an earlier date, record information below:

Approximate hours at change

If not, change as follows:

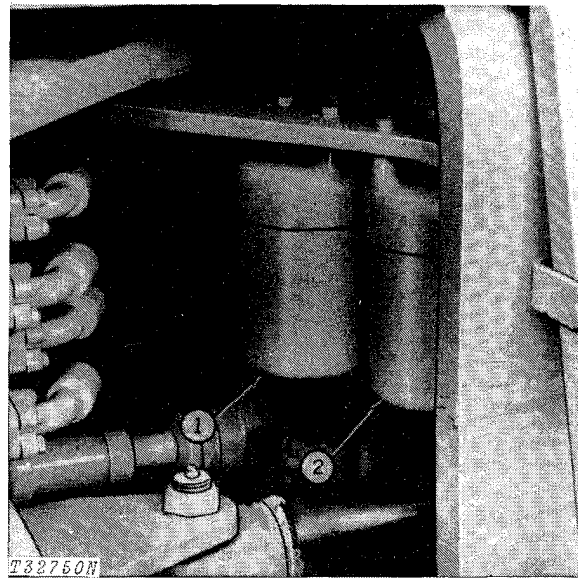

1—Transmission Filter

2—Steering Oil Filter

Fig. 48-Oil Filters

Remove both the transmission and steering return oil filters. Replace both elements, packings, and O-rings. Tighten filter covers to 55 lb-ft (7.6 kg/m).

Check transmission oil level.

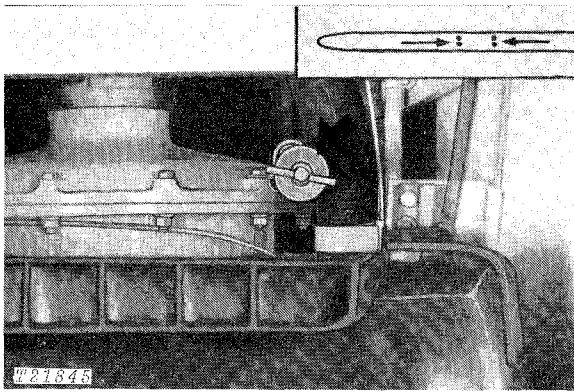

Fig. 49-Transmission Dipstick

A dipstick, located on the left side of the transmission, is accessible by tilting the back of the seat forward. The correct oil level check is made with the dipstick fully inserted in dipstick tube.

Perform both of the following transmission oil level checks: (a) Before starting the engine check the oil level with dipstick. If the oil level is at or near the upper (FULL) mark, there is sufficient oil in the system to permit starting the engine. If oil level is low add John Deere Torque-Converter Fluid (Type C-3) or an equivalent. Replace dipstick and tighten finger tight.

**IMPORTANT: Do not use John Deere HY-GARD Oil in the transmission.**

Start engine and check for leaks around filter elements. Retighten if necessary, but do not overtighten.

(b) Operate loader until the transmission reaches normal operating temperature. Idle the engine and shift through all ranges slowly. This will fill all parts in the system with oil. Shift to neutral, apply the brakes and allow engine to idle. Check oil level again. It should now be at or above the lower (ADD) mark and not above the upper (FULL) mark on the dipstick. If below the add mark, add oil. Do not overfill.

Transmission and steering  
 filters changed  
 Oil added, if any

Yes No  
 \_\_\_\_\_ qts. (L)

#### 4. Front and Rear Differential Oil Level

Check front and rear differential oil level.

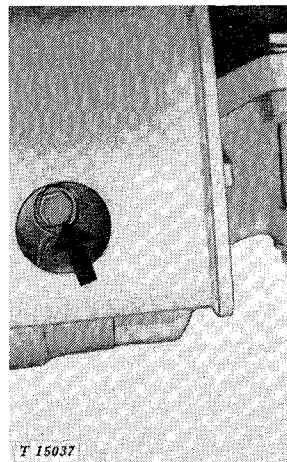

Fig. 50-Front Differential  
 Check Plug

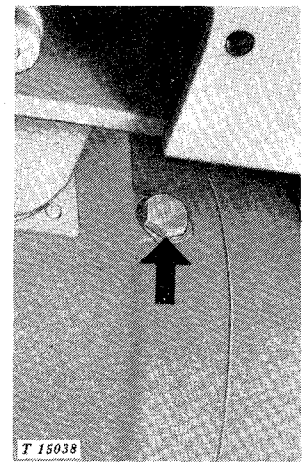

Fig. 51-Rear Differential  
 Check Plug

Check oil level at oil level - filler plug on the side of the differential housings. Oil must be cold and loader must be on level ground. The oil level should be up to the plug. Add John Deere HY-GARD Oil or an equivalent, if necessary.

Differential oil levels  
 checked  
 Oil added, if any

Yes No  
 \_\_\_\_\_ qts. (L)

#### 5. Radiator

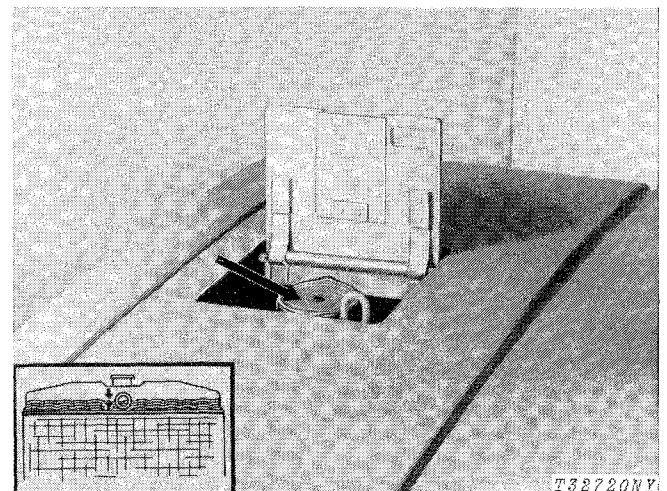

Fig. 52-Radiator Filler Cap

**CAUTION:** Do not remove radiator filler cap until the coolant temperature is below its boiling point. Then loosen cap to the stop to relieve pressure before removing cap completely.

Check the level of the coolant in the radiator. Coolant level should be midway between the radiator core and filler neck.

Radiator coolant level checked	Yes	No
Coolant or antifreeze added, if any	_____ qts. (L)	

### 6. Check Lubrication

Check each lubrication point shown on following pages. Lubricate with several strokes, if necessary.

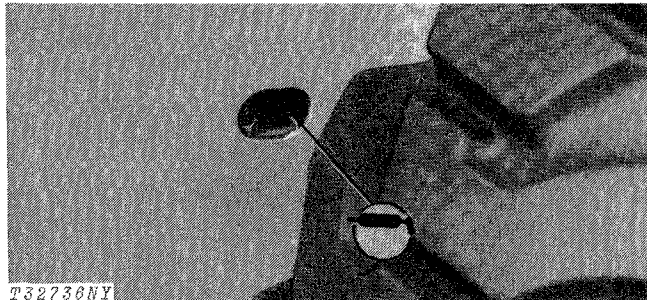

Fig. 53-Steering Cylinder Rear Pivot Pins (2 Points)

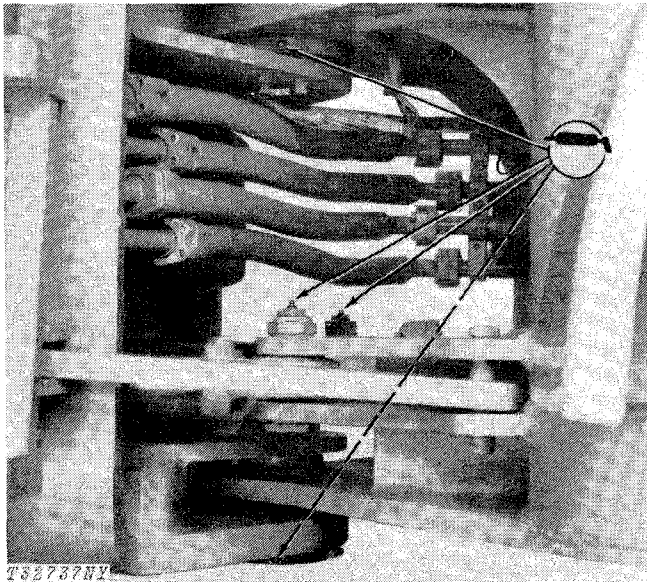

Fig. 54-Steering Cylinder Front Pivot Pins (2 Points) and Frame Hinge Pivots (2 Points)

Lubricant required	Yes	No
--------------------	-----	----

Lubricate all pivot points in the linkage from the control lever to the control valves with engine oil.

Lubricant required	Yes	No
--------------------	-----	----

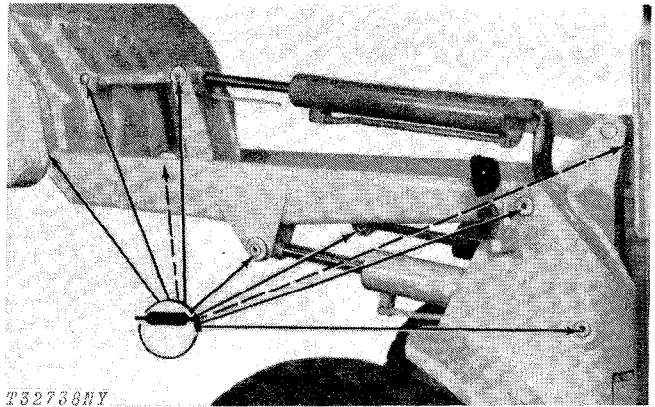

Fig. 55-Loader Boom and Bucket Cylinders and Pivots (12 Points)

Lubricant required	Yes	No
--------------------	-----	----

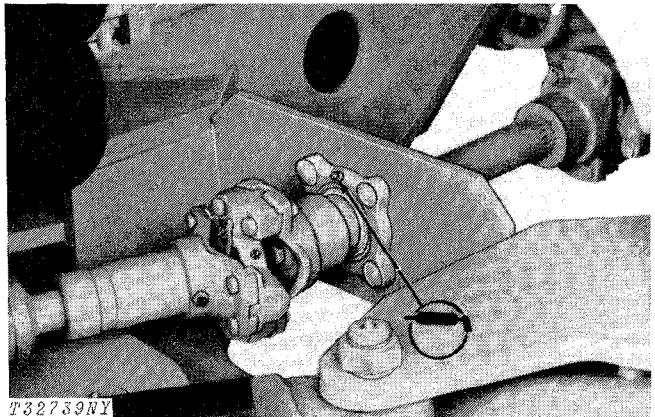

Fig. 56-Front Drive Shaft Support Bearing (1 Point)

Lubricant required	Yes	No
--------------------	-----	----

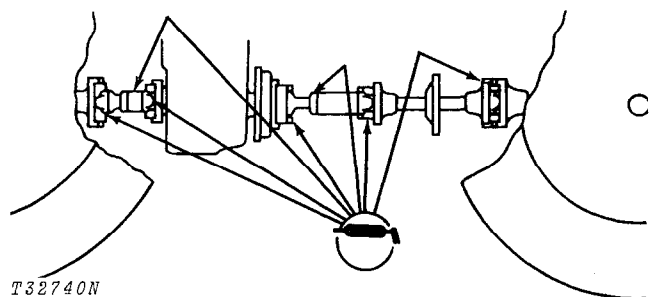

Fig. 57-Transmission-to-Differential Drive Lines (7 Points)

Lubricant required	Yes	No
--------------------	-----	----

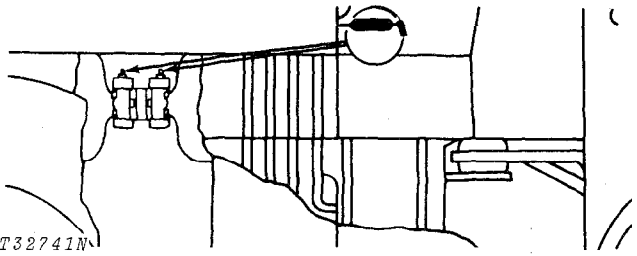

Fig. 58-Engine-to-Transmission Universal Joint (2 Points)

Lubricant required Yes No

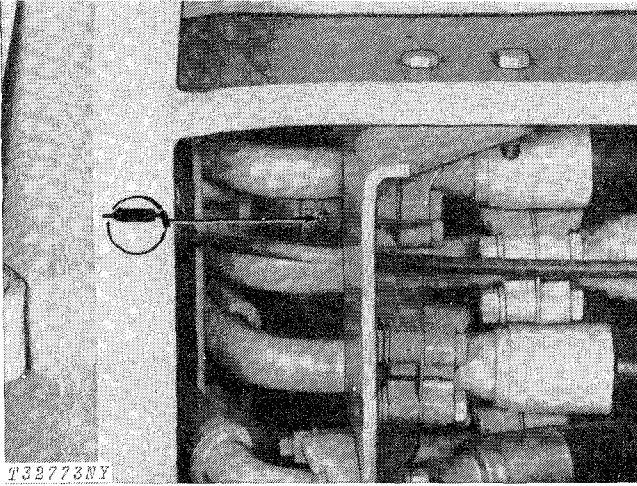

Fig. 59-Shift Control Bell Crank Fitting (1 Point)

Lubricant required Yes No

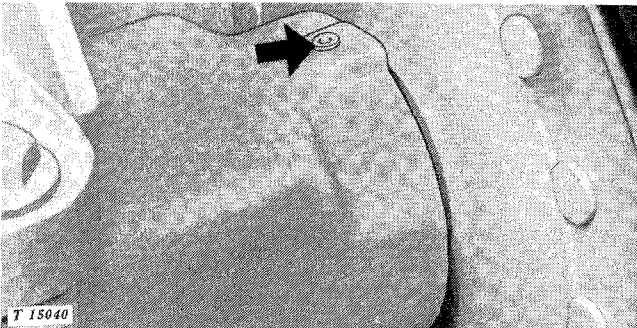

Fig. 60-Axle Bearing Plug (Front Shown) (4 Points)

If lubrication is required, remove pipe plug in each wheel and install grease fittings.

Lubricant required Yes No

## 7. Pre-cleaner

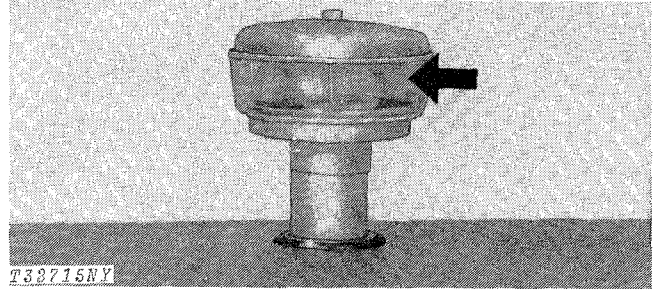

Fig. 61-Pre-Cleaner

Check and clean pre-cleaner bowl.

Pre-cleaner checked and cleaned

Yes No

## 8. Air Cleaner

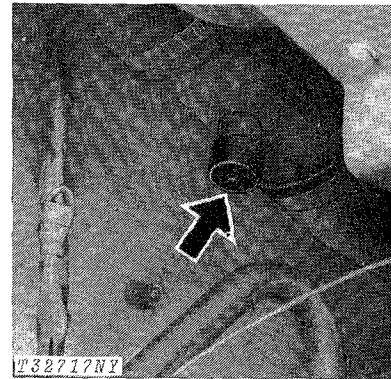
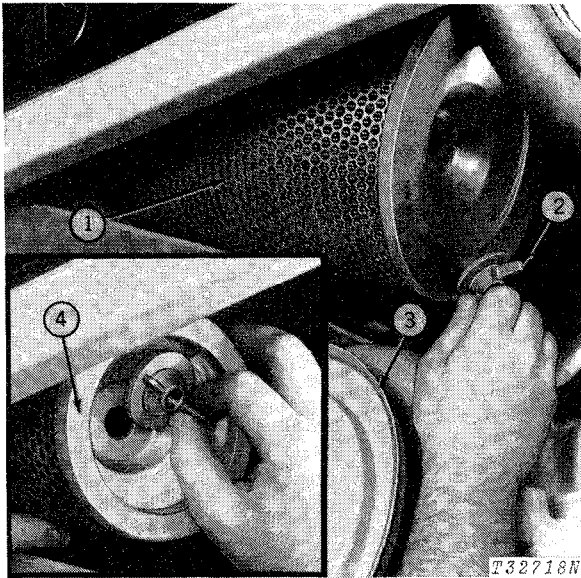

Fig. 62-Air Cleaner Restriction Indicator

Check air cleaner restriction indicator. If the indicator shows red, check and clean primary element. Replace primary element and secondary element, if necessary.



1—Primary Element  
 2—Wing Nut  
 3—Air Cleaner Cap  
 4—Secondary Element

Fig. 63—Air Cleaner

Air cleaner checked	Yes	No
Elements replaced or cleaned	Yes	No

### 9. Fuel Tank Outlet Screen

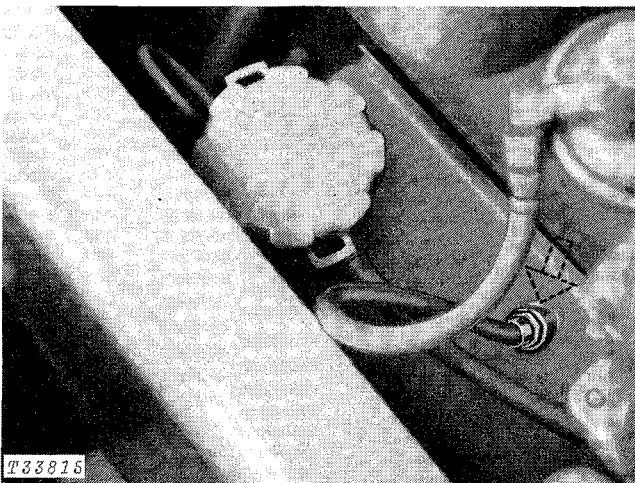

Fig. 64—Fuel Tank Outlet Screen

Remove fuel line from fuel tank outlet screen and remove outlet screen from fuel tank. Backflush and clean, if necessary. Replace outlet screen in fuel tank and replace fuel line.

Fuel tank outlet screen cleaned	Yes	No
---------------------------------	-----	----

### 10. Tire Pressure

Check the air pressure in all the tires with an accurate gauge having 1-psi (0.07 kg/cm<sup>2</sup>) graduations.

**IMPORTANT: All tires must be inflated to the same pressure.**

Adjust pressure in tires to the following specifications.

Tire Size	Ply Rating	Inflation Pressures Minimum	Inflation Pressures Normal
14.00-24	12	50 psi (3.5 kg/cm <sup>2</sup> )	60 psi (4 kg/cm <sup>2</sup> )
17.5-25	12	40 psi (3 kg/cm <sup>2</sup> )	50 psi (3.5 kg/cm <sup>2</sup> )
23.1-26*	10	20 psi (1.5 kg/cm <sup>2</sup> )	

\*Use with log loader or tree shear only.

Tire pressure checked	Yes	No
-----------------------	-----	----

### 11. Fuel Filter

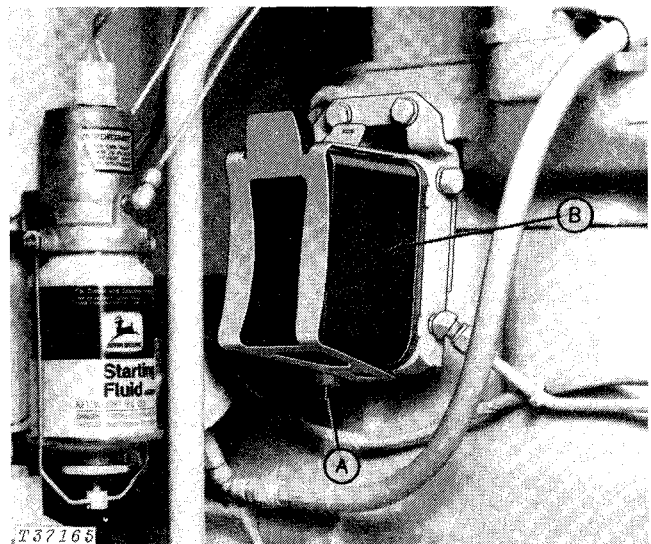

A—Fuel Filter Drain Plug  
 B—Fuel Filter

Fig. 65—Fuel Filter

Check fuel filter and drain any sediment that is present.

Sediment present in filter	Yes	No
----------------------------	-----	----

## 12. Batteries

Check battery electrolyte level. Batteries are located to the left of the operator and are accessible through the top door in the battery compartment. If distilled water is not available, use clean soft water. Avoid use of hard water. Remove foreign material from top of battery and coat terminals with petroleum jelly. Check vent holes in battery caps.

**IMPORTANT: Never add water to battery in freezing weather unless engine is to be run two or three hours to assure mixing of water and electrolyte.**

Water added Yes No

## 13. Charging System

Check the charging system as follows:

- a. With the engine off the voltmeter should be in the lower left green zone (12-13 volts).
- b. With the engine running the voltmeter should be in the upper green zone (14-15 volts).

Charging system operational Yes No

## 14. Light Operation

Check light operation.



Fig. 66-Light Switch

The headlights, combination stop lights and taillights and the work lights are controlled by a push-pull light switch located on the right hand dash panel.

The light switch has three positions:  
 Completely In - All lights are off.

First Position (Halfway Out) - Headlights and combination stop lights and taillights are on.

Second Position (Completely Out) -

Work lights, headlights and combination stop lights and taillights are on.

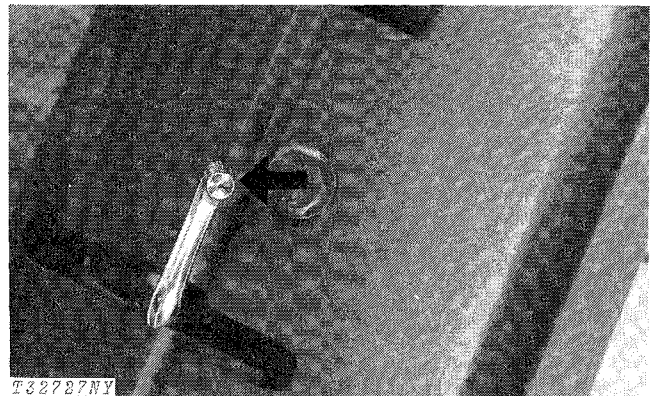

Fig. 67-Turn Signal and Warning Light Switch

The turn signal and warning light control switch is used to indicate a right or left turn. To indicate a left turn, pull switch lever counterclockwise. To indicate a right turn push switch lever to first clockwise position.

The flashing warning lights may be turned on by turning the switch fully clockwise (second position).

Lights operational Yes No

## 15. Gauge Operation

When operating the loader, check all gauges to see if they are operational and indicator hands are responsive.

Gauges operational Yes No

If no, explain malfunction \_\_\_\_\_

\_\_\_\_\_

\_\_\_\_\_

\_\_\_\_\_

## 16. Check Engine Speeds

To increase both the life and productivity of the unit accurate speed measurements should be made with the engine, transmission and hydraulics at normal operating temperature.

Engine rpm should be 2375 - 2425 at fast idle and 700 at slow idle. If engine speeds do not agree with the above adjust as follows:

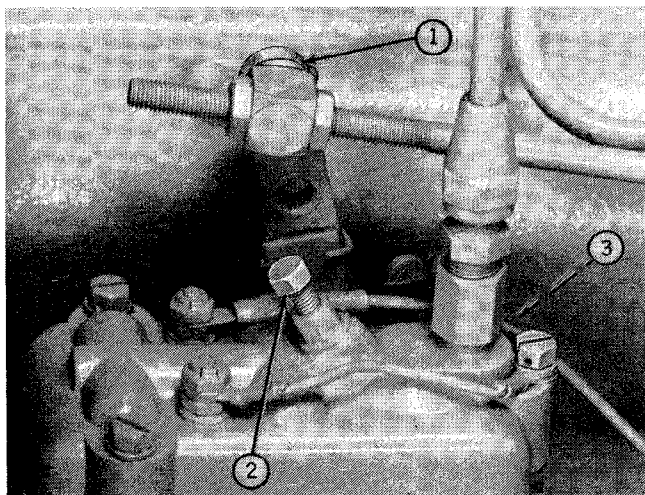

1—Throttle Lever                      3—Fast Idle Stop Screw  
 2—Slow Idle Adjusting Screw

Fig. 68-Pump Idle Adjustments

Disconnect throttle swivel from injection pump lever. Run engine and rotate pump throttle lever to rear until it touches stop. Engine speed should be at 2375 - 2425 rpm fast idle. If not, adjust pump fast-idle stop screw to correct.

Lightly rotate pump throttle lever forward to slow-idle position. Engine speed should be at 700 rpm slow idle. If not, adjust at pump slow-idle stop screw.

### Linkage Adjustments

Override on pump throttle lever should be 1/4-inch (6 mm) preloaded at both fast and slow idle positions. Proceed with speed adjustments as follows:

With engine off, position fast idle adjustment screw located under accelerator pedal 2.00 in. (51 mm) above platform lugs. Lock screw in place.



T35891N

1—Platform                                      4—Fast Idle Adjustment Screw  
 2—Accelerator Pedal                      5—2.00 inches (51 mm)  
 3—Slow Idle Screw

Fig. 69-Accelerator Pedal Adjustments

Disconnect throttle swivel from injection pump lever. Hold the accelerator pedal down against fast idle screw. At the injection pump, pull the lever against fast idle position and hold. Adjust swivel on the injection pump control rod so the pin will just go into position. Remove the swivel from the lever. Shorten the injection pump control rod 3-1/2 turns. Tighten locking nut.

Allow accelerator pedal to return to slow idle position. With engine running adjust length of slow idle stop screw under accelerator pedal until engine rpm just increases from slow idle setting. Back out slow idle adjusting screw 2 turns (1/8 in. [3 mm]). Tighten locking nut.

Engine speeds checked	Yes	No
Adjustments required	Yes	No

### 17. Upper Pivot Pin Stop Nut

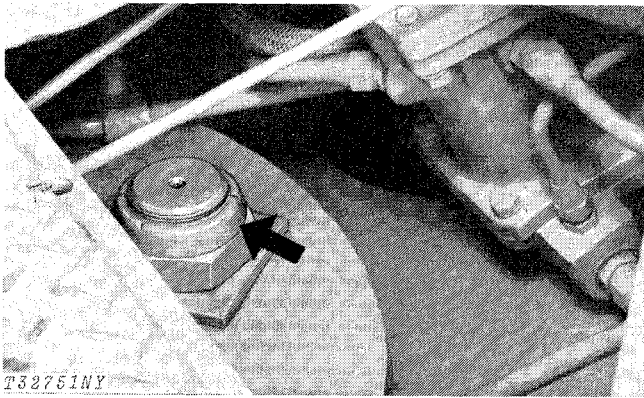

Fig. 70-Upper Pivot Pin Stop Nut

Remove right-hand floor panel. Tighten upper pivot pin stop nut to 1000 lb-ft (138 kg-m).

Pivot pin stop nut tightened Yes No

### 18. Wheel Retaining Cap Screws

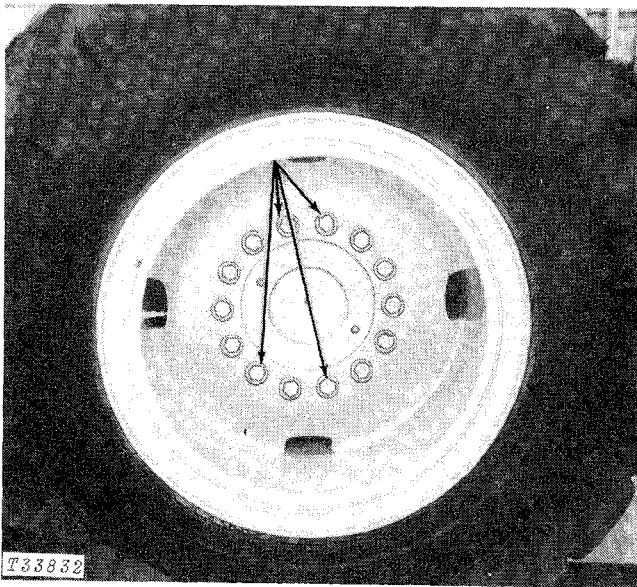

Fig. 71-Wheel Retaining Cap Screws

Check all wheel retainer cap screw torque. Tighten wheel retaining cap screws to 300 lb-ft (41.48 kg/m).

Wheel retaining cap screws tightened Yes No

### 19. Parking Brake

Check the parking brake for proper adjustment. Adjust, if necessary.

*NOTE: It requires 45 pounds (20 kg) of force at the handle to activate the parking brake. If the force is more or less than 45 pounds (20 kg), adjust the parking brake.*

Adjust parking brake by turning parking brake lever knob until the lever locks tightly over center. When no longer possible to turn the knob, unscrew it completely and make the adjustment in the rod and yoke assembly where it attaches to the transmission brake lever. Adjust length so that the parking brake lever locks tightly over center with the knob on the parking brake lever completely unscrewed.

Check to make sure transmission output shaft is not leaking oil on the brake drum.

Also check for scorched paint on brake drum. This would indicate loader is being driven with parking brake on.

Parking brake operational Yes No

## 20. Check No-Spin Differential Operation

Check operation of the no-spin differential. The front drive wheels should both turn at the same rate, providing full power to each wheel under varying tractive conditions.

However, during turns or when operating on uneven terrain, an overriding clutch within the differential automatically unlocks, providing the necessary differential action.

No-spin differential  
operation

Yes No

## 21. Clutch Control

Check the clutch control operation.

**CAUTION:** The clutch control knob should be pushed in (KNOB IN position) when transporting the loader. The clutch control knob should be pulled out (KNOB OUT position) during loading and dumping operations only. The clutch control knob should be pushed in (KNOB IN position) before stopping on steep inclines. The loader clutch control knob can be pushed in (KNOB IN position) while the brakes are applied.

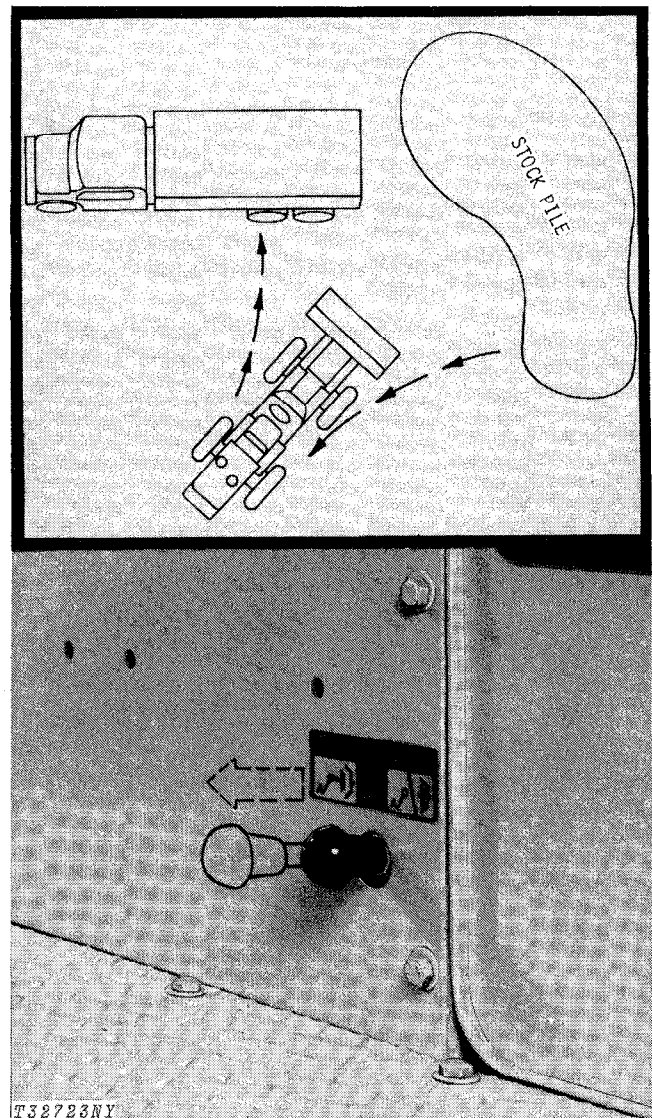

Fig. 72-Transmission Clutches Disengaged By Brake Pedal

The loader transmission is equipped with a clutch control valve. This valve is operated by a knob located below the seat. With the knob pulled out, the transmission clutches are disengaged when the brake pedal is depressed. When the knob is in this position, the operator, with a full bucket, can approach a truck with the engine at full throttle, depress the brake pedal which disengages the transmission—and obtain maximum hydraulic speed. The unit will not creep forward with the brakes applied.

After the bucket has been emptied into the truck, the operator shifts the loader into reverse and releases the brakes. When the brake line pressure drops, the transmission clutches re-engage in the normal manner.

The clutch control valve enables the operator to speed up loading and dumping operations.

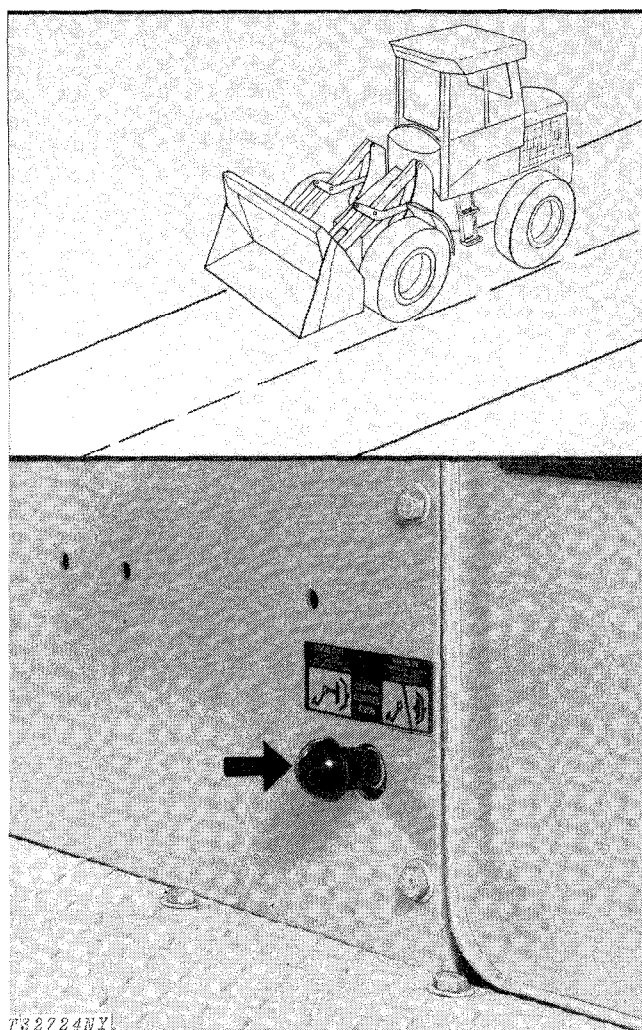

Fig. 73-Transmission Clutches Not Disengaged By Brake Pedal

Clutch control operational Yes No

## 22. Check Accumulator Action

If braking action is poor or erratic after bleeding the brakes, check the brake accumulator reserve capacity as follows:

Before starting engine, operate brake pedal several times. Pedal travel should not exceed 2 inches with firm but moderate pedal effort. Excessive pedal travel means the accumulator has no reserve capacity.

Start engine and run approximately one minute. Stop engine and discharge steering accumulator by cycling steering wheel. Operate brake pedal twenty applications. After twenty applications, pedal travel should not exceed 2 inches with firm but moderate pedal effort. If accumulator does not have sufficient reserve capacity, have your John Deere dealer check the accumulator.

Accumulators checked Yes No

## 23. Rear Axle Disconnect

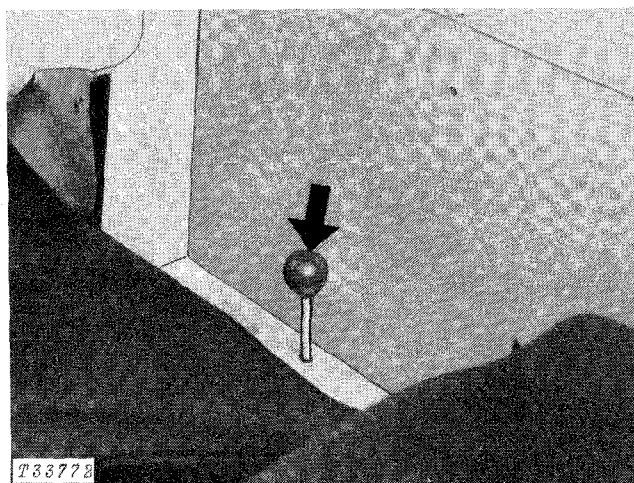

Fig. 74-Rear Axle Disconnect Lever

Check the loader rear axle disconnect operation.

Push down on lever located behind the seat to engage rear axle and pull up to disengage rear axle. This option assures maximum transport speeds.



**IMPORTANT:** Do not engage or disengage the rear axle with the loader in motion. Pivot the loader frame slowly from side to side while engaging or disengaging the axle.

Rear axle disconnect operational Yes No

### 24. Accessible Hardware Torque Values

Check all accessible bolts and nuts for proper tightness. Discuss with the customer the importance of maintaining the proper tightness of all loader hardware. If hardware is loose, tighten it to the proper torque. The chart below gives correct torque values for various bolts and cap screws. Most hardware used is high-strength (note dashes on hex. heads).

#### STANDARD TORQUE CHART

RECOMMENDED TORQUE IN LB-FT [Kg-m] COARSE AND FINE THREADS			
<div style="display: flex; justify-content: space-around; align-items: center;"> <div style="text-align: center;"> <p>B</p>  </div> <div style="text-align: center;"> <p>D</p>  </div> <div style="text-align: center;"> <p>F</p>  </div> </div>			
Bolt Diameter	Plain Head	Three Dashes	Six Dashes
1/4	Not used	10 1.4	14 1.9
5/16	Not used	20 2.8	30 4.1
3/8	Not used	35 4.8	50 6.9
7/16	35 4.8	55 7.6	80 11.1
1/2	55 7.6	85 11.8	120 16.6
9/16	75 10.4	130 18.0	175 24.2
5/8	105 14.5	170 23.5	240 33.2
3/4	185 25.6	300 41.5	425 58.8
7/8	160 22.1	445 61.5	685 94.7
1	250 34.6	670 92.5	1030 142.4
1-1/8	330 45.6	910 125.8	1460 201.9
1-1/4	480 66.4	1250 172.8	2060 284.8

T30882

Fig. 75-Torque Chart

The types of bolts and cap screws are identified by head markings as follows:

Plain Head: regular machine bolts and cap screws.

3-Dash Head: tempered steel high-strength bolts and cap screws.

6-Dash Head: tempered steel extra high-strength bolts and cap screws.

Machine bolts and cap screws 7/8-inch (22 mm) and larger are sometimes formed hot rather than cold, which accounts for lower torque.

All accessible hardware torqued Yes No

### 25. Fluid Leakage

Check the following systems for leakage due to poor or faulty connections and broken hoses or lines.

- |                                   |     |    |
|-----------------------------------|-----|----|
| A. Cooling system checked OK      | Yes | No |
| B. Hydraulic system checked OK    | Yes | No |
| C. Transmission system checked OK | Yes | No |
| D. Fuel system checked OK         | Yes | No |

If answer to any of the above is no, please explain.

# Group 15 LUBRICATION

## GENERAL INFORMATION

Illustrated below is the periodic service chart which is mounted on the front of the battery box. More detailed information on servicing the loader can be found in the current JD544-B operator's manual.

Use the operator's manual and the periodic service chart as references when servicing the loader. Remind your customer to thoroughly read the operator's manual before attempting to service or operate the loader.

**PERIODIC SERVICE CHART**  
 REFER TO OPERATOR'S MANUAL FOR MORE DETAILED INFORMATION

INTERVAL HOURS	ITEM NO.	COMPONENTS	SERVICE POINTS	DESCRIPTION OF SERVICE	CAPACITY OR MEASUREMENT	APPROVED SERVICE MATERIAL
10 OR DAILY	1	PRE-CLEANER	1	CHECK LEVEL OF ACCUMULATED MATERIAL	AS INDICATED ON BOWL	
	2	AIR CLEANER	1	SEE LABEL ON AIR CLEANER		
	3	ENGINE CRANKCASE	1	CHECK OIL LEVEL	BETWEEN MARKS ON DIP STICK	OPERATOR'S MANUAL
	4	FRAME HINGE PIVOTS	2	LUBRICATE GREASE FITTINGS	2 OR 3 INJECTIONS	SAE MFG
	5	STEERING CYLINDER PIVOT PINS	4	LUBRICATE GREASE FITTINGS	2 OR 3 INJECTIONS	SAE MFG
	6	LOADER BOOM & CYLINDER PIVOTS	12 JD444 12 JD544 14 JD644	LUBRICATE GREASE FITTINGS	2 OR 3 INJECTIONS	SAE MFG
	7	LOADER RESERVOIR	1	CHECK OIL LEVEL AT RESERVOIR WINDOW	SEE OPERATOR'S MANUAL	OPERATOR'S MANUAL
	8	RADIATOR	1	CHECK COOLANT LEVEL	MIDWAY BETWEEN RADIATOR CORN & FILLER NECK	OPERATOR'S MANUAL
	9	FUEL FILTER	1 JD444 1 JD544 2 JD644	CHECK FOR SEDIMENT	CLEAN AS REQUIRED	OPERATOR'S MANUAL
	10	TRANSMISSION	1	CHECK OIL LEVEL	SEE OPERATOR'S MANUAL	C-2 TRANS. FLUID
	11	FRONT DRIVE SHAFT SUPPORT BEARING	1	LUBRICATE GREASE FITTING	ADD GREASE UNTIL FRESH GREASE ESCAPES AROUND SEAL	SAE MFG
	12	AXLE BEARINGS * (DEEP MUD OR WATER OPERATION)	4	INSTALL GREASE FITTINGS & LUBRICATE	6 OR 8 LOW PRESSURE INJECTIONS	SAE MFG
	13	TRANSMISSION TO DIFFERENTIAL DRIVE LINES (DEEP MUD OR WATER OPERATION)	7	LOW PRESSURE LUBRICATION OF GREASE FITTING	1 OR 2 INJECTIONS	SAE MFG
	50	14	LOADER CONTROL LEVER	1 OR 2	LUBRICATE LEVER PIVOT POINTS	
15		TIRES	4	CHECK AIR PRESSURE	SEE OPERATOR'S MANUAL	
100	16	BATTERIES	2	CHECK ELECTROLYTE LEVEL CHECK TERMINALS FOR CORROSION	BOTTOM OF FILLER NECK REMOVE ANY CORROSION	DISTILLED WATER
	17	ALTERNATOR & FAN BELTS	1	CHECK TENSION	SEE OPERATOR'S MANUAL	
	18	SHIFT CONTROL BELLCRANK	1	LUBRICATE GREASE FITTING	1 OR 2 INJECTIONS	SAE MFG
200	19	TRANSMISSION TO FRONT DIFFERENTIAL TELESCOPING SHAFT	1	LOW PRESSURE LUBRICATION OF GREASE FITTING	1 OR 2 INJECTIONS	SAE MFG
	20	ENGINE CRANKCASE **	1	DRAIN & REFILL	JD444 12 U.S. QTS. (11.5 LTS) *** JD544 18 U.S. QTS. (17 LTS) *** JD644 20 U.S. QTS. (19 LTS) ***	OPERATOR'S MANUAL OPERATOR'S MANUAL OPERATOR'S MANUAL
	21	CRANKCASE OIL FILTER	1 JD444 2 JD544 3 JD644	REPLACE		
500	22	FRONT & REAR DIFFERENTIALS	2	CHECK OIL LEVEL	LEVEL WITH CHECK PLUG	OPERATOR'S MANUAL
	23	FUEL TANK OUTLET SCREEN	1 JD444 1 JD544	REMOVE, CLEAN & REINSTALL		
	24	AXLE BEARINGS *	4	INSTALL GREASE FITTINGS & LUBRICATE, THEN REPLUG	10 TO 20 LOW PRESSURE INJECTIONS	SAE MFG
	25	TRANSMISSION TO DIFFERENTIAL DRIVE LINES	7	LOW PRESSURE LUBRICATION OF GREASE FITTINGS	1 OR 2 INJECTIONS	SAE MFG
	26	UNIVERSAL JOINT ENGINE TO TRANSMISSION	2	LOW PRESSURE LUBRICATION OF GREASE FITTINGS	LUBRICATE UNTIL FRESH GREASE ESCAPES AROUND BEARING CAPS	SAE MFG
	27	LOADER RESERVOIR RETURN FILTER	1 JD444 1 JD544 2 JD644	REPLACE FILTERS		JOHN DEERE FILTERS
	28	FUEL FILTERS	1 JD444 1 JD544 2 JD644	REPLACE FILTERS		JOHN DEERE FILTERS
1000	29	FRONT & REAR DIFFERENTIALS	2	DRAIN & REFILL	SEE OPERATOR'S MANUAL	OPERATOR'S MANUAL
	30	LOADER RESERVOIR	1	DRAIN, FLUSH & REFILL	SEE OPERATOR'S MANUAL	OPERATOR'S MANUAL
	31	AIR CLEANER	1	REPLACE BOTH ELEMENTS	SEE OPERATOR'S MANUAL	OPERATOR'S MANUAL
	32	TRANSMISSION	1	DRAIN, CHANGE FILTERS & REFILL	SEE OPERATOR'S MANUAL	OPERATOR'S MANUAL
	33	STARTER (ELECTRIFY ONLY)	1	LUBRICATE WICKS	SATURATE WICKS	SAE 10W ENGINE OIL

\* LUBRICATION NOT RECOMMENDED AT TEMPERATURES BELOW 60°F (16°C)  
 \*\* CHANGE BREAK-IN OIL & FILTERS AFTER 100 HOURS OF USE  
 \*\*\* WHEN LOADER IS USED DURING PREVAILING AIR TEMPERATURES BELOW 10°F (-23°C), CHANGE OIL AFTER EVERY 100 HOURS OF OPERATION OR EVERY 6 WEEKS OF INTERMITTENT OPERATION, WHICHEVER OCCURS FIRST  
 \*\*\*\* ADD 2 QUARTS (2 LITRES) WITH FILTER CHANGE  
 MFG = MULTIPURPOSE GREASE

AIR TEMPERATURE	JOHN DEERE TORQ-GARD OIL	SINGLE VISCOSITY OIL	MULTI VISCOSITY OIL
ABOVE 32°F (0°C)	SAE 30	SAE 30	NOT RECOMMENDED
32°F to 10°F (0°C to -23°C)	SAE 10W-20	SAE 10W	SAE 10W-20 SAE 10W-30
BELOW 10°F (-23°C)	SAE SW 20	SAE SW	SAE SW 20

T47269N

Fig. 1-Periodic Service Chart

## LUBRICANTS

Use only lubricants specified in this section; apply them at intervals and according to the instructions in the lubrication and periodic service section.

### ENGINE OILS



John Deere TORQ-GARD SUPREME® engine oil is recommended for use in the engine crankcase.

Oils other than TORQ-GARD SUPREME must conform to the following specifications:

#### SINGLE VISCOSITY OILS

API Service CD/SC  
 MIL-L-2104C  
 Series 3

#### MULTI-VISCOSITY OILS

API Service CC/SE  
 MIL-L-46152

Depending on average temperature use oil as follows:

Air Temperature	John Deere TORQ-GARD SUPREME OIL	Single Viscosity	Other Oils Multi-Viscosity Oil
Above 32°F (0°C)	SAE 30	SAE 30	Not recommended.
-10°F to 32°F (23°C to 0°C)	SAE 10W-20	SAE 10W	SAE 10W-30
Below -10°F (-23°C)	SAE 5W-20	SAE 5W	SAE 5W-20

Oil consumption may increase when SAE 5W-20 or SAE 5W oils are used. Check oil level more frequently.

### TRANSMISSION, STEERING, AND BRAKE SYSTEM

Use John Deere Torque-Converter Fluid (Type C-3) or an equivalent.

### LOADER HYDRAULIC SYSTEM AND DIFFERENTIALS

Use John Deere HY-GARD® Transmission and Hydraulic Oil (J20A) or an equivalent.

**IMPORTANT: Do not use John Deere HY-GARD Oil in the transmission.**

### GREASES

Use John Deere Multi-Purpose Grease or an equivalent for all grease fittings.

### STORING LUBRICANTS

Use clean containers to handle all lubricants. Store them in an area protected from dust, moisture, and other contamination.

# Section 20 ENGINE

## CONTENTS

	Page		Page
GROUP 5 - ENGINE REMOVAL AND INSTALLATION		GROUP 20 - ENGINE COOLING SYSTEM	
Removal.....	5-3	General Information .....	20-1
Installation.....	5-4	Radiator	
GROUP 10 - BASIC ENGINE		Removal.....	20-1
General Information .....	10-1	Repair.....	20-1
Cylinder Head and Valves		Installation.....	20-1
Valve Lift Check.....	10-1	Water Pump	
Removal.....	10-2	Removal.....	20-1
Repair.....	10-2	Repair.....	20-1
Assembly.....	10-4	Installation.....	20-3
Installation.....	10-4	GROUP 25 - FUEL SYSTEM	
Camshaft		General Information .....	25-1
Removal.....	10-6	Fuel Tank	
Repair.....	10-6	Removal.....	25-1
Installation.....	10-7	Repair.....	25-1
Cylinder Block, Liners, Pistons and Rods		Installation.....	25-2
Removal.....	10-8	Fuel Filter	
Repair.....	10-8	Removal.....	25-2
Installation.....	10-11	Repair.....	25-3
Crankshaft, Main Bearings, and Flywheel		Installation.....	25-3
Removal.....	10-13	Fuel Transfer Pump	
Repair.....	10-13	Removal.....	25-3
Installation.....	10-15	Repair.....	25-3
Timing Gear Train		Installation.....	25-3
Removal.....	10-19	Fuel Injection Pump	
Repair.....	10-19	Removal.....	25-4
Installation.....	10-20	Repair.....	25-5
GROUP 15 - ENGINE LUBRICATION SYSTEM		(Refer to SM-2045 "Testing and Servicing Fuel Injection Pumps and Nozzles")	
General Information .....	15-1	Installation and Timing.....	25-5
Oil Pump		Bleeding.....	25-6
Removal.....	15-1	Fuel Injection Nozzles	
Repair.....	15-2	Removal.....	25-6
Installation.....	15-2	Repair.....	25-7
Oil Pressure Regulating Valve		(Refer to SM-2045 "Testing and Servicing Fuel Injection Pumps and Nozzles")	
Removal.....	15-2	Installation.....	25-7
Repair.....	15-3	GROUP 30 - SPEED CONTROL LINKAGE	
Installation.....	15-3	General Information .....	30-1
Oil Filters and Housing			
Removal.....	15-3		
Repair.....	15-3		
Installation.....	15-3		
Oil Cooler			
Removal.....	15-4		
Repair.....	15-4		
Installation.....	15-4		

*Contents continued on next page*

## CONTENTS—Continued

	Page		Page
GROUP 35 - AIR INTAKE SYSTEM		GROUP 40 - SPECIFICATIONS AND SPECIAL TOOLS	
General Information .....	35-1	Engine Removal and Installation .....	40-1
Air Cleaner		Basic Engine .....	40-3
Removal .....	35-1	Engine Lubrication System .....	40-19
Repair .....	35-2	Engine Cooling System .....	40-21
Installation .....	35-2	Fuel System .....	40-24
Turbocharger		Speed Control Linkage .....	40-26
Removal .....	35-2	Air Intake System .....	40-26
Testing .....	35-3		
Repair .....	35-4		
Installation .....	35-7		
Intake Manifold			
Removal .....	35-8		
Repair .....	35-8		
Installation .....	35-8		

## Group 5 ENGINE REMOVAL AND INSTALLATION

### REMOVAL

Operate controls to release hydraulic pressure from loader hydraulic system and steering and brakes hydraulic system.

Pull pins from pivot lock bar on engine frame and lock bar between engine and loader frames. Disconnect battery ground strap.

Remove muffler, pre-cleaner (or air cleaner stack), grille screen, hood, and engine side shields.

Drain radiator. Disconnect inlet and outlet hoses. Disconnect transmission oil cooler hoses and oil cooler line clamps (6, Fig. 1) to right side of engine block.

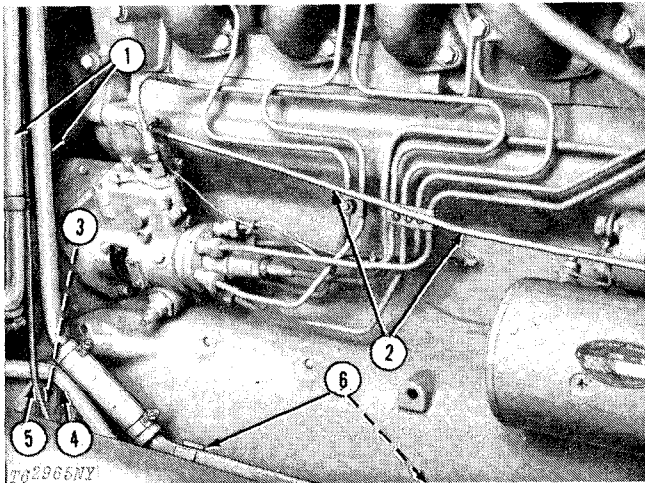

- |                                    |                                       |
|------------------------------------|---------------------------------------|
| 1—Transmission Oil Cooler Lines    | 4—Transmission Oil Line               |
| 2—Speed Control Rod                | 5—Fuel Leak-Off Line                  |
| 3—Right Rear Engine Mounting Point | 6—Transmission Oil Cooler Line Clamps |

Fig. 1-Disconnecting Right Side of Engine

Disconnect speed control rod from fuel injection pump.

Disconnect fuel leak-off line at both ends.

Disconnect rear lights from main wiring harness. Remove the transmission oil cooler, radiator, and grille housing as one assembly by removing grille housing to engine frame hardware.

Disconnect transmission oil lines from engine-mounted hydraulic pump.

Disconnect hydraulic steering lines from pump. Remove clamps from lines to aid in engine removal. Also disconnect rear pump oil seal drain return tube.

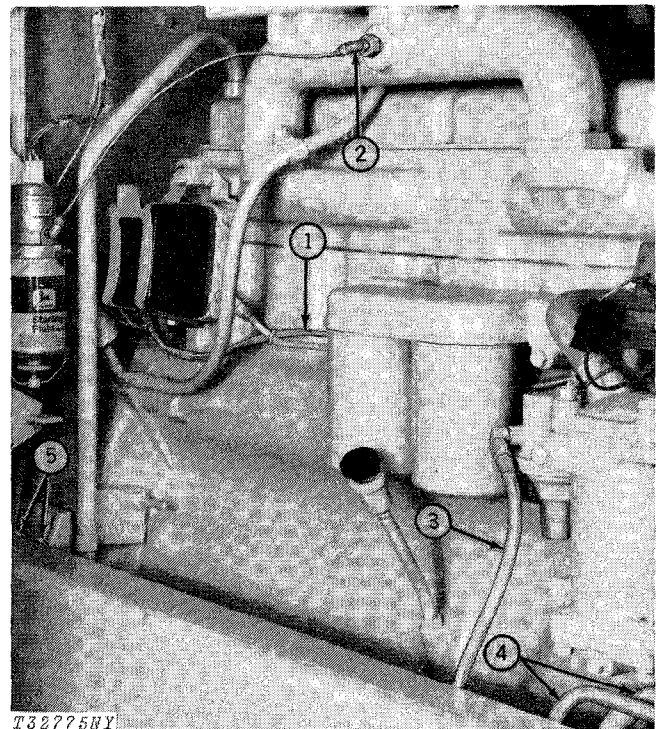

- |                         |                                    |
|-------------------------|------------------------------------|
| 1—Engine Wiring Harness | 4—Hydraulic Steering Line          |
| 2—Start Aid Tube        | 5—Left Front Engine Mounting Point |
| 3—Fuel Line             |                                    |

Fig. 2-Disconnecting Left Side of Engine

Disconnect fuel line at transfer pump.

Disconnect engine wiring harness at connector through canopy support. Also disconnect the wires of the engine harness from the solenoid on the canopy support. Disconnect the battery cable at the starter. Disconnect the oil pressure tube.

*NOTE: For tractors equipped with cab heater, disconnect heater hoses from engine and remove clamps mounting hose to engine.*

Disconnect starting aid tube from engine.

Hold oil drain line on inside of engine frame and remove large hex. nut on outside of frame.

Disconnect transmission drive shaft at flywheel end of engine.

Attach JD-244 Lifting Eyes or JDG-19 Lifting Bracket to engine and D01043AA Load Positioning Sling or JDG-1 or JDG-23 Engine Lifting Sling to lifting eyes. Attach chain hoist to sling.

With the hoist supporting the engine, remove cap screws securing rear engine brackets to engine frame. Remove front (flywheel end) engine brackets from engine and engine frame for extra clearance during engine removal.

Remove the engine.

## INSTALLATION

Position engine in engine frame and tighten hardware.

Connect transmission drive shaft to flywheel end of engine. Connect engine wiring harness to connector and to solenoid on canopy support. Connect battery cable at starter.

Connect fuel line to fuel transfer pump.

Connect transmission oil and hydraulic steering lines to rear pump and install oil seal drain return tube. Install and tighten all clamps.

Install grille housing assembly, making sure all baffling is in place. Connect rear lights to main wiring harness.

Connect radiator and oil cooler hoses, and fuel leak-off line.

Connect oil pressure tube.

Connect heater hoses and starting aid tube, if used.

Connect speed control rod to fuel injection pump.

Assemble engine oil drain to engine frame.

Install muffler, hood, pre-cleaner (or air cleaner stack), and grille screen.

Fill radiator.

Connect battery ground strap. Remove pivot lock bar from between engine and loader frames.

 **CAUTION: Escaping fluid under pressure can have sufficient force to penetrate the skin, causing serious personal injury. Before disconnecting lines, be sure to relieve all pressure. Before applying pressure to system, be sure all connections are tight and that lines, pipes and hoses are not damaged. Fluid escaping from a very small hole can be almost invisible. Use a piece of cardboard or wood, rather than hands, to search for suspected leaks.**

**If injured by escaping fluid, see a doctor at once. Serious infection or reaction can develop if proper medical treatment is not administered immediately.**

Start engine and check fuel line, all hydraulic lines, and radiator hoses for leaks.



**Suggest:**

**If the above button click is invalid.**

**Please download this document**

**first, and then click the above link**

**to download the complete manual.**

**Thank you so much for reading**

## Group 10 BASIC ENGINE

### GENERAL INFORMATION

This is a turbocharged (optional equipment), liquid cooled, 6-cylinder, diesel fueled valve-in-head, vertical in-line four-cycle engine.



For basic theory of engine operation see "Basic Engine" in FOS Manual - ENGINES.

The cylinder head is a one-piece casting which holds the rocker arm assembly, valves and valve springs.

The valve guides are integral with the cylinder head. Valve seats are replaceable alloy inserts. The valves have chrome-plated stems and replaceable wear caps. The exhaust valves are made of inconel. Valve rotators are mounted above both intake and exhaust valves.

The camshaft is driven at one-half engine speed by the crankshaft gear and supported by four pressure lubricated bores integral with the cylinder block. Camshaft thrust is taken by a thrust plate fastened to the fan end of the cylinder block. The camshaft lobes are tapered. The cam followers are mushroom-shaped with a crowned face.

The cylinder block is a one-piece casting equipped with seven main bearings.

The six cylinder liners are wet-sleeve replaceable types. Each liner has a square rubber packing that seals at a shoulder on the liner. Two O-rings packings fit in grooves in the cylinder bore. The square and O-ring packings seal the liner at the bottom of the cylinder bore. The top of the liner is sealed by cylinder head gasket compression.

Pistons are cast aluminum alloy, cam ground and weight controlled. Each has two compression rings and an oil control ring. Pistons are spray jet cooled.

Piston pins fit into bronze bushings in the connecting rod. Each connecting rod has replaceable bearing inserts.

### CYLINDER HEAD AND VALVES

#### Valve Lift Check

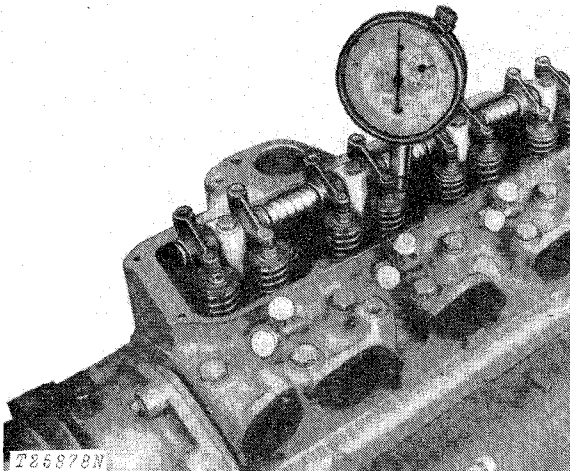

Fig. 1-Checking Valve Lift

Measuring valve lift can give an indication of wear to cam lobes, cam followers and push rods.

Set valve clearance to 0.014 inch [0.36 mm] for intake valves and 0.018 inch [0.46 mm] for exhaust valves.

Place dial indicator on valve rotator (Fig. 1). (Be sure that valve is fully closed and the rocker arm moves freely.) Zero dial indicator.

Manually turn engine in running direction. Check indicator travel as the rocker arm moves valve to full open.

Indicator should read  $0.475 \pm 0.015$  inch [12.065  $\pm$  0.381 mm] for intake valves and  $0.470 \pm 0.015$  inch [11.938  $\pm$  0.381 mm] for exhaust valves.

**<https://www.ebooklibonline.com>**

Hello dear friend!

Thank you very much for reading.

Enter the link into your browser.

The full manual is available for immediate download.

**<https://www.ebooklibonline.com>**