

483 AND 484 STALKERS



JOHN DEERE

TECHNICAL MANUAL 483 AND 484 STALKERS

TM1168 (01SEP77) English

OTTUMWA WORKS
TM1168 (01SEP77)

LITHO IN THE U.S.A.
ENGLISH



483 AND 484 STALKERS

TECHNICAL MANUAL

TM-1168 (SEP-77)

CONTENTS

	Page		Page
Introduction	2	Fenders, Gatherer Points and Caps	18
Safety and You	3	Removal	18
Specifications, Torque Values and Special Tools	4, 5	Installation	19
General Information	6	Outer Gatherer Points	19
Row Units	6	Center Gatherer Points	19
Serial Number	6	Rear Cap	19
Diagnosing Malfunctions	7	Removing Row Unit	20
Organizing The Diagnosis	7	Removing Row Unit Gear Case	20
Diagnosing	7, 8, 9	Disassembly	21
Lubrication	10	Inspection	22
Greases	10	Assembly	22
Torque Chart	11	Knife Assembly	25
Row Units	12	Disassembly	25
General Information	12	Inspection	26
Removal	12	Assembly	26
Row Unit Drive Shaft	12	Replacing Idlers	29
Inspection	12	Auger	30
Installation	13	General Information	30
Adjusting Backlash	14	Feeder Fingers	30
Feed Roll	15	Removal	31
Removal	15	Inspection	32
Inspection	15	Assembly (Feeder Fingers)	33
Installation	15	Assembly (Auger)	34
Main Drive Shaft	16	Adjustments	35
Removal	16		
Inspection	16		
Installation	17		

All information, illustrations and specifications contained in this technical manual are based on the latest information available at the time of publication. The right is reserved to make changes at any time without notice.

Because John Deere sells its products world-wide, U.S. units of measure are shown with their respective metric equivalents throughout this technical manual. These equivalents are the SI (International System) Units of Measure.

Copyright © 1977
DEERE & COMPANY
Moline, Illinois
All rights reserved

INTRODUCTION



Use FOS Manuals for Reference

This technical manual is part of a twin concept of service:

- **FOS Manuals—for reference**
- **Technical Manuals—for actual service**

The two kinds of manuals work as a team to give you both the general background and technical details of shop service.

Fundamentals of Service (FOS) Manuals cover basic theory of operation, *fundamentals* of trouble shooting, *general* maintenance, and *basic* types of failures and their causes. FOS Manuals are for training new mechanics and for reference by experienced mechanics.

Technical Manuals are *concise* service guides for a *specific* machine. Technical Manuals are on-the-job guides containing only the vital information needed by an experienced mechanic.

When a service person should refer to a FOS Manual for more information, a FOS note is used in the TM to identify the reference.



Use Technical Manuals for Actual Service

Some features of this technical manual.

- *Table of contents at front of manual*
- *Exploded views showing parts relationship*
- *Photos showing service techniques*
- *Specifications grouped for easy reference*

This technical manual was planned and written for you—an experienced mechanic. Keep it in a permanent binder in the shop where it is handy. Refer to it whenever in doubt about correct service procedures or specifications.

 This safety alert symbol identifies important safety messages in this manual. When you see this symbol, be alert to the possibility of personal injury and carefully read the message that follows.

<https://www.ebooklibonline.com>

Hello dear friend!

Thank you very much for reading.

Enter the link into your browser.

The full manual is available for immediate download.

<https://www.ebooklibonline.com>

SAFETY AND YOU



T27999N

INTRODUCTION

 This safety alert symbol identifies important safety messages in this manual and on the stalker. When you see this symbol, be alert to the possibility of personal injury and carefully read the message that follows.

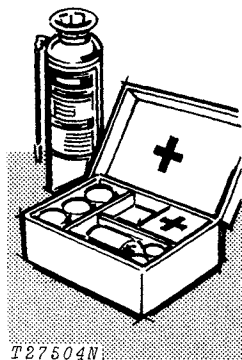

T27504N

Be prepared if an accident or fire should occur. Know where the first-aid kit and the fire extinguishers are located—know how to use them.

PERSONAL SAFETY

Avoid working on equipment with the harvester engine running. If it is necessary to make checks with the engine running, **ALWAYS USE TWO PEOPLE**—one, the operator, at the controls, the other person checking so as to be visible to the operator on the tractor seat. **KEEP HANDS AWAY FROM MOVING PARTS.**

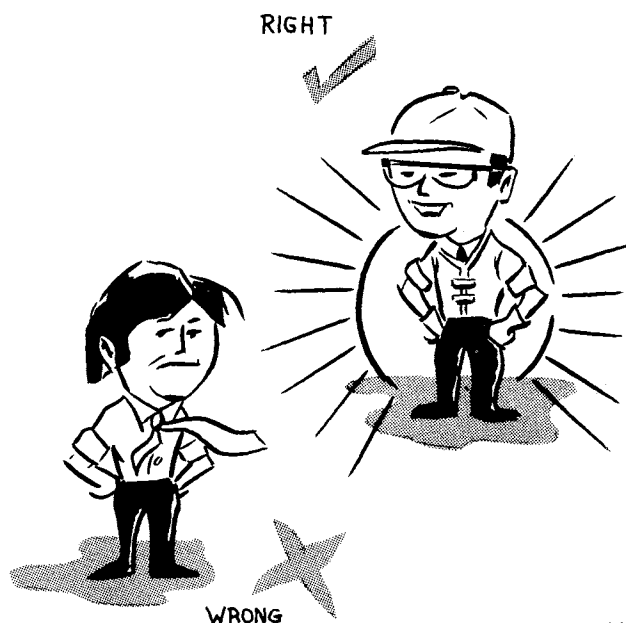

H23440N

Always avoid loose clothing or any accessory—flopping cuffs, dangling neckties and scarves—that can catch in moving parts and put you out of work.

Always wear your safety glasses while on the job.

SERVICE AREA

Keep the service area clean and dry. Wet or oily floors are slippery. Wet spots can be dangerous when working with electrical equipment.

Make sure the service area is adequately vented.

Periodically check the shop exhaust system for leakage. Engine exhaust gas is dangerous.

Be sure all electrical outlets and tools are properly grounded.

Use adequate light for the job at hand.

SPECIFICATIONS, TORQUE VALUES AND SPECIAL TOOLS

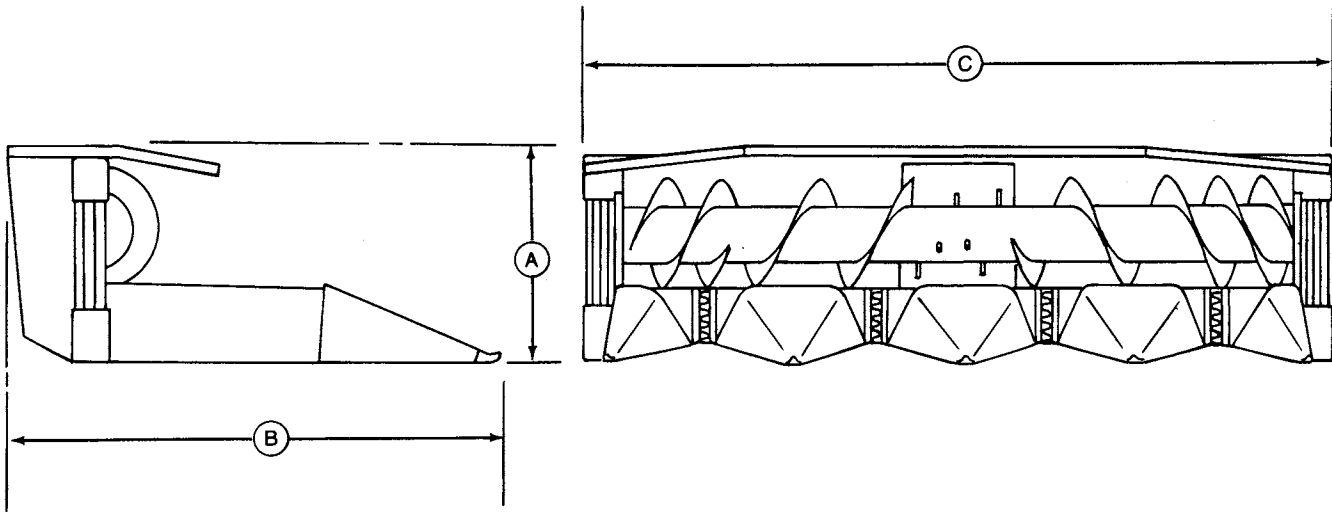

E14904

A—Height	52 in. (1 321 mm)
B—Length	110 in. (2 794 mm)
C—Width:	
483, 4-Row 30 in. (762 mm)	131 in. (3 327 mm)
484, 4-Row 40 in. (1 016 mm)	159 in. (4 039 mm)

Fig. 1-Dimensions for 483 and 484 Stalkers

Weight:

483 - 4-Row 30 in. (762 mm)	2906 lbs. (1318 kg)
484 - 4 Row 40 in. (1 016 mm)	3106 lbs. (1409 kg)

Gear Case:

Input Shaft	
End Play	0.005 to 0.015-in. (0.13 to 0.38 mm)
Backlash	0.005-in. (0.13 mm) Min.

Speed:

Auger	86 rpm
Gatherer Chain	370 ft/min. (112 m/min.)
Knife	920 cuts per minute
Power Corner Feed Roll	345 rpm

Slip Clutch

One per row unit plus cross auger drive

Gatherer Chains	Heavy-Duty 555 endless steel roller chain (No master connecting link)
Knives	Tungsten carbide edge, oscillating type
Height of Cut	Minimum 3-1/4 in. (83 mm) Maximum 33 in. (830 mm)
Gatherer Points	Low-profile, floating type
Auger:	
Diameter	22 in. (559 mm)
Tube	12 in. (305 mm)
Flighting	5 in. (127 mm)
Row Unit Drive	Heavy-duty casting containing all gears; lubricated with two Multi-Lubers; protected with slip clutch and driven by single input hex. shaft
Backlash	0.004 to 0.025-in. (0.10 to 0.63 mm)
Gear Heel	0.020-inch (0.51 mm)

TORQUE VALUES

Location	Torque (Ft-Lbs)	(Nm)	(kgm)
Ball Stud Nut	40	56	5.6
Pitman Cap Screw (7/8-in.)	300	407	41
Knife Socket Head Cap Screw	80	108	10.8
Knife Socket Head Nut	80	108	10.8
Knife Crank Clamp Bolt	85	115	12
Knife Link Clamp Bolt	20	27	2.7
Knife Retainer	85	115	11.5
Gather Chain Driven Sprockets	125	170	17
Gatherer Chain Drive Sprockets	85	115	11.5
Auger Fingers	90	122	12
Auger Drive Shaft (Slotted nut)	180	244	24

SPECIAL TOOLS

Convenience Tools

Tool No.	Description	Use
MTD-AF-3*	Socket	To remove platform auger fingers
JDO-1**	Puller	To remove idler and drive sprocket

* Order from: Midwest Tool Specialities, P. O. Box 176, Silvis, Ill. 61282

**Order from: Owatonna Tool Company, Owatonna, Minnesota 55060

GENERAL INFORMATION

ROW UNITS

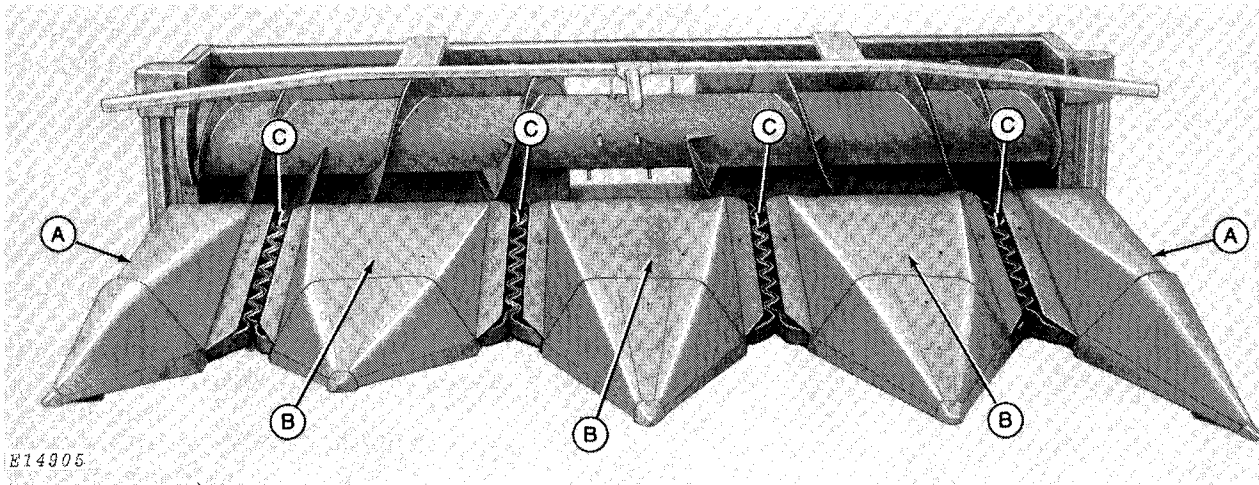

A—Outside Fenders

B—Center Islands

C—Row Units

Fig. 2-Stalker Row Units and Covers

As the stalker moves into the crop, the oscillating knife assembly cuts the stalks while the gatherer chains grasp the material and move it toward the auger. The auger then moves the material toward the center of the stalker and into the harvester feed rolls.

To operate properly, the gatherer chains must be timed and the gear case must have proper backlash and heel.

It is not necessary to remove each row unit to service the drives.

⚠ CAUTION: Be certain the support stands are lowered and the stalker unit is blocked properly before working beneath the row unit.

SERIAL NUMBER

The serial number for the 483 or 484 Stalker is located below the multi-luber, on the left-hand side panel.

DIAGNOSING MALFUNCTIONS

The majority of operating problems that occur with the stalkers can be sometimes traced to improper adjustment or delayed service. The following malfunctions are designed to help you when a problem develops by suggesting a problem, cause, and the recommended solution.

These suggested malfunctions should be applied with caution. Make certain the source of the problem is not located someplace other than where the problem exists. A thorough understanding of the stalker is a must if operating problems are to be corrected satisfactorily.

ORGANIZING THE DIAGNOSIS

1. Know the Unit

Study this manual to know how the individual components work and their function in the over-all system.

Keep up with the latest service information. Read it and store it in a handy reference file.

2. Consult the Operator

Ask the operator how the unit was performing when the problem occurred. Find out if any corrective measures were already taken. Ask if the unit was serviced regularly as prescribed in the operator's manual.

3. Operate the Unit

If the unit can be safely operated, see for yourself how it malfunctions—don't completely rely on the operator's diagnosis.

4. Inspect the Unit

Visually check the unit. Look at the components for any cracked welds, loose hardware, damaged linkages, worn or broken lines, or anything that looks out of the ordinary.

5. List the Probable Causes

Write down the information you have learned by steps 1 through 4. What are the signs you found while inspecting the unit and what are the most probable causes as outlined under "Diagnosing"?

6. Reach Some Conclusions

Look over the possible causes and decide which ones are the most likely. Reach your decision on the most probable cause and plan to check it first.

7. Test Your Conclusions

Before disassembling any components, test your conclusions to see which are correct. Tests narrow the possibilities and soon the actual cause will be pinpointed.

DIAGNOSING

Gatherer Chains Out of Time

Gatherer Chains Loose.

Tighten gatherer chains (See page 35.)

Material Under Chain in Sprocket Roller Pockets.

Clean material accumulations around sprockets.

Material Collects Against Chain Sprockets.

Reverse harvester no longer than necessary to clear plugged machine.

Knife Plugs.

Raise knife, adjust hydraulic down stop actuator. (See operator's manual.)

Gatherer Chains Stiff.

Oil chains.

Belt Trough Plugging with Material.

See "Plugging", page 9.

Gather Chain Drive Sprockets Out of Time.

Re-time sprockets. (See page 24.)

Idler Support Bracket Loose.

Tighten or replace support bolts.

Bearing Failure in Gatherer Chain Idler.

Replace gatherer chain idler.

Material Wraps Around Power Corners

Stripper Clearances Excessive.

Adjust stripper. (See page 37.)

Bent or Nicked Flutes on Power Corner.

Straighten and smooth rough edges.

Down and Tangled Material.

Reverse machine to clean.

Ragged Stubble Left On Ground

- Improper knife register.
Adjust knife register, page 40.
- Excessive knife clearance.
Shim side knives, page 39.
- Excessive ground speed.
Reduce ground speed.
- Knives not centered on row.
Center harvester on rows.
- Header set too high.
Adjust down stop. See operator's manual.
- Worn knives.
Replace knives, page 40.

Leaves Too Much Stalklage

- Excessive ground speed for crop condition.
Reduce ground speed.
- Poor preparation of stalks.
- Improper row spacing.
- Outer points not spaced properly.
Adjust outer points, page 35.
- Stalker set too high.
Adjust down stop.
- Improper direction of travel.
Reverse direction of travel.
- Points improperly adjusted.
Adjust points vertically and evenly, page 36.

Auger Carry-Over At Feed Opening

- Feed rolls in harvester not taking crop.
Check for proper function of feed rolls. See your Self-Propelled Harvester Operator's Manual.
- Auger fingers too aggressive.
Retard auger fingers, page 37.
- Excessive ground speed.
Reduce ground speed.

Length of Cut Lacks Uniformity

- Stalks entering feed rolls crossways.
Stay on rows and/or correct row spacing.
- Improper direction of travel.
Reverse direction of travel.
- Harvesting crop residue.
Use proper recutter screen.

Outer Gatherer Point Interferes With Standing Crop

- Outer points improperly adjusted.
Move outer gatherer points in. See page 35.
- Not harvesting planter rows.
Harvest rows as they were planted.
It will be easier to follow the rows,
reduce plugging and eliminate loss of crop.

Short Gatherer Chain Life

- Gatherer chain too tight.
Adjust gather chain, page 35.
- Using old idlers with new gatherer chain.
Replace idlers if worn, page 29.
- Belt trough or idlers plugging with material.
See "Plugging" section, page 9.
- Using rear ear deflectors when harvesting stalklage.
Remove.

Stalker Drops Too Fast or Slow

- Rate of drop not set properly.
Re-set rate of drop.

Plugging

Ground speed too fast.
Slow down. Operate at a speed to meet the yield and ground condition.

Stalker set too low.
Adjust down stop. See operator's manual.

Excessive knife clearance.
Shim side knives, page 39.

Improper knife register.
Adjust knife register, page 40.

Row unit drive chain loose.
Tighten chain, page 39.

Slip clutches slipping.
Adjust slip clutches, page 38.

Excessive clearance between idler support bracket and deck.
Replace gatherer chain.

Gatherer chains loose.
Adjust gatherer chains, page 35.

Idler arm support bracket bent.
Straighten or replace, page 29.

Excessive knife shield clearance.
Adjust knife shield, page 39.

Front ear deflectors.
Remove.

Knives worn.
Replace knives, page 26.

Rear ear deflectors.
Remove.

Auger Not Feeding

Auger drive chain loose.
Tighten chain. See page 39.

Excessive ground speed.
Reduce ground speed.

Clutch slipping.
Adjust, page 38.

Short Gatherer Belt Life

Belts rubbing on center or rear island shields.
Provide at least 1/8-inch (3 mm) clearance between gatherer chain belting and shields.

Material wrappage in belt path.
Remove material.

Rocks or foreign material in rows.
Raise stalker by adjusting hydraulic down stop actuator. See operator's manual.

Gatherer chains not timed properly.
Time gatherer chains, page 24.

Using rear ear deflectors when harvesting stalklage.
Remove.

Material Falling From Gatherer Chains

Gatherer chains loose.
Adjust gatherer chains, page 35.

Gatherer chains out of time.
Time gatherer chains, page 24.

Excessive chain guide clearance.
Adjust chain guide, page 38.

Gatherer chain belting worn and/or collapsed.
Replace belting.

Upper crop guide not at correct height.
Regulate height if 1977 model year or newer.

Excessive Ears on Ground in Whole Plant Operation

Ears coming off stalk and falling on ground from gatherer chain return.
Install rear ear deflectors, see operator's manual.

Ears coming off stalk and sliding down the islands onto ground.
Install optional front ear deflectors, see operator's manual.

LUBRICATION

Carefully written and illustrated lubrication instructions are included in the operator's manual furnished with your customer's machine. Remind the customer to follow these instructions.

For your convenience, the following chart shows capacities and types of lubricants for the Stalker. Specifications for lubricants follow the chart.

Component	Capacity	Type of Lubricant	Interval of Service
Roller Chains	John Deere PT 508 Special Lubricant or SAE 30 engine oil	Daily
Multi-Luber	John Deere Quik-Lube Lubricant (AN 11100) or an equivalent	Every 10 Hours
Oscillating Knife	John Deere Multi-Purpose Lubricant or an equivalent SAE multi-purpose-type grease.	Every 50 Hours
Gears	John Deere Multi-Purpose Lubricant or an equivalent SAE multi-purpose-type grease	Every 50 Hours
Upper Crop Guides (1977 Model Year Option)	John Deere Multi-Purpose Lubricant or an equivalent SAE multi-purpose-type grease	Every 50 Tours





GREASES

John Deere Multi-Purpose Lubricant or an equivalent SAE multipurpose-type grease is recommended for all grease fittings. Application of grease as instructed in the lubrication chart will provide proper lubrication and will prevent contamination of bearings.

STORING LUBRICANTS

The stalker can operate efficiently only if clean lubricants are used. Use clean containers to handle all lubricants. Store them in an area protected from dust, moisture, and other contaminants.

TORQUE CHART

RECOMMENDED TORQUE IN FT-LBS (Nm) COARSE AND FINE THREADS			
    			
Bolt Diameter	Plain Head	Three Dashes	Six Dashes
1/4	Not used	10 (14)	14 (19)
5/16	Not used	20 (27)	30 (41)
3/8	Not used	35 (47)	50 (68)
7/16	35 (47)	55 (75)	80 (108)
1/2	55 (75)	85 (115)	120 (163)
9/16	75 (102)	130 (176)	175 (237)
5/8	105 (142)	170 (230)	240 (325)
3/4	185 (251)	300 (407)	425 (576)
7/8	160 (217)	445 (603)	685 (929)
1	250 (339)	670 (908)	1030 (1397)
1-1/8	330 (447)	910 (1234)	1460 (1980)
1-1/4	480 (651)	1250 (1695)	2060 (2793)

E11579N

The types of bolts and cap screws are identified by head markings as follows:

Plain Head: regular machine bolts and cap screws.

3-Dash Head: tempered steel high-strength bolts and cap screws.

6-Dash Head: tempered steel extra high-strength bolts and cap screws.

Machine bolts and cap screws 7/8-inch and larger are sometimes formed hot rather than cold, which accounts for the lower torque.

ROW UNITS

GENERAL INFORMATION

It is not necessary to remove the row unit to perform service on the gear case, gatherer chain or oscillating knife assemblies.

If row unit service necessitates working under the unit frame, be certain to lower support stands and block stalker to prevent accidental lowering.

ROW UNIT DRIVE SHAFT

Removal

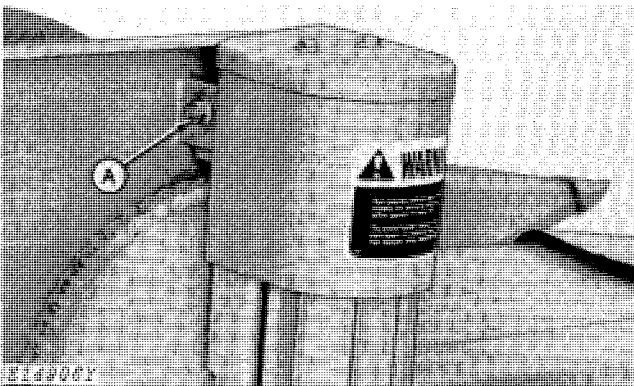

A—Cap Screw

Fig. 3—Lowering Feed Roll Frame

1. Remove 1/2 x 6-inch cap screw (A) from each upper feed roll attaching point.
2. Rotate each feed roll unit to the ground.

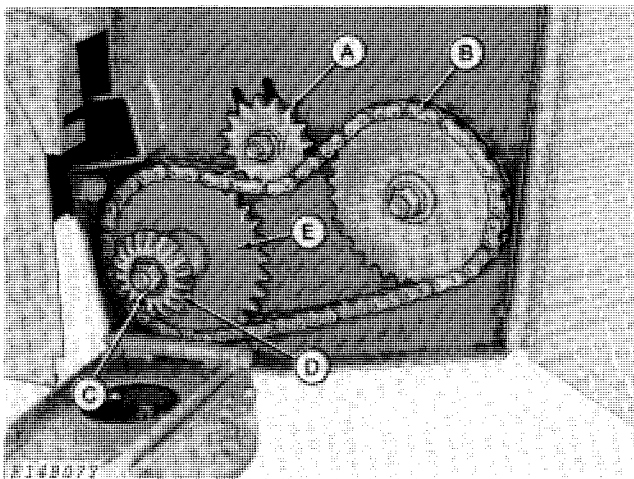

A—Idler
B—Drive Chain
C—Lock Nut
D—28-Tooth Gear
E—30-Tooth Sprocket

Fig. 4—Removing Drive Sprocket

3. Loosen idler (A) and remove row unit drive chain (B).

4. For ease in removing, clean drive shaft of all paint and foreign material.

5. Remove 3/4-inch lock nut (C) and large heat-treated washer from left-hand end of drive shaft. Remove 18-tooth gear (D) from each end of drive shaft.

6. Remove flat washers, push drive shaft in and remove 30-tooth sprocket (E) from left-hand end of drive shaft. Do not lose flat washers while removing gears and sprocket. These are needed for adjustment during assembly.

7. Remove bearing flanges and bearing from left-hand end of row unit drive shaft. Loosen on right-hand end.

8. Pull row unit drive shaft from left-hand side of stalker.

Inspection

Wash all parts thoroughly in a clean, safe solvent and dry.

Inspect all parts for wear or damage. Replace if necessary.

Check the gears and sprocket for irregular wear patterns, nicks, broken teeth, etc.

Check bearings for roughness. Be certain they rotate freely.

Installation

Refer to Fig. 5 to help install the row unit drive shaft.

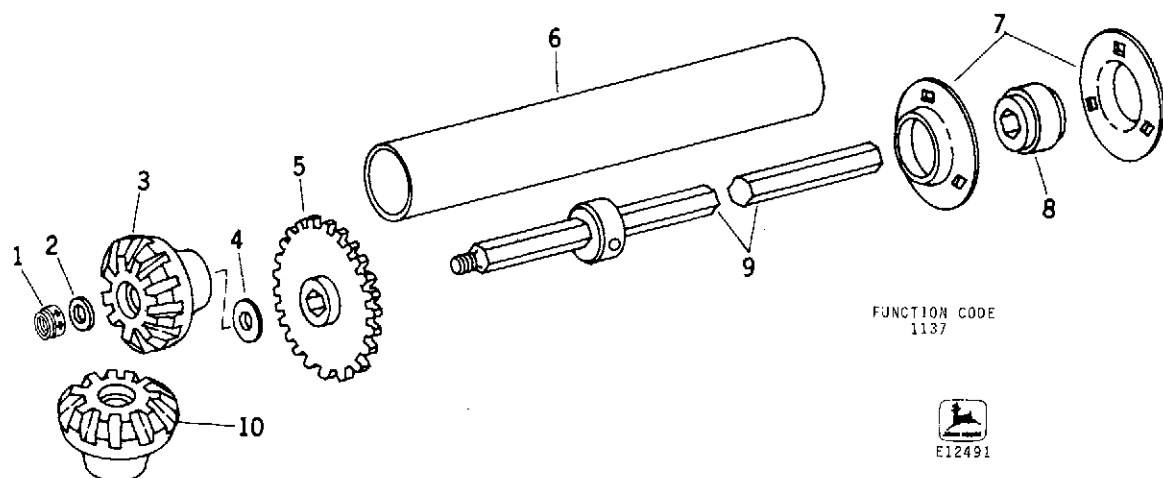

1—Lock Nut
2—Heat Treated Washer
3—18-Tooth Gear (2 used)
4—Washer (use as required)

5—30-Tooth Sprocket
6—Shield
7—Flange (4 used)

8—Bearing (2 used)
9—Drive Shaft
10—18-Tooth Gear (2 used)

Fig. 5—Exploded View of Row Unit Drive Shaft

- Slide row unit drive shaft and shields into stalker.
- Install bearings and flanges on left-hand end of row unit drive shaft. Do not tighten either end securely at this time.
- Place 30-tooth sprocket (E, Fig. 4) and all 1-13/32 x 1-3/4 x 0.120-inch and 1-13/32 x 2 x 0.030-inch washers on left-hand side of drive shaft.
- Place 18-tooth gear on both ends of drive shaft and adjust left-hand end using washers (4, Fig. 5) until 7/64-inch (2.8 mm) dimension (A, Fig. 6) is obtained.
- Place heat treated washer and lock nut on drive shaft. Torque lock nut to 150 ± 20 ft-lbs (210 ± 27 Nm). Tighten carriage bolts on flanges.
- Install row unit drive chain and tighten idler.

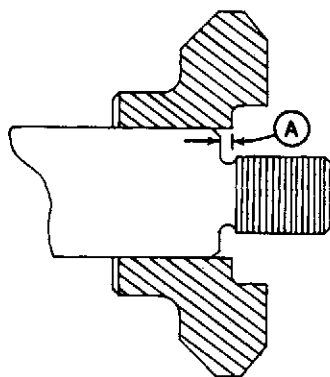

E14908

A—7/64-inch (2.8 mm)

Fig. 6—Adjusting Row Unit Drive

- Rotate feed roll unit into position and secure using 1/2 x 6-inch cap screw and lock nut.
- Remove lower feed roll shield and check gear backlash (3 and 10, Fig. 5). Backlash must not exceed 0.004 to 0.025-inch (0.10 to 0.64 mm) when heel of gears is within 1/32-inch (0.79 mm). See page 14 for row unit backlash adjustment.
- See page 39 to adjust row unit drive chain.



Suggest:

If the above button click is invalid.

Please download this document

first, and then click the above link

to download the complete manual.

Thank you so much for reading

ROW UNIT DRIVE SHAFT—Continued

Adjusting Row Unit Backlash

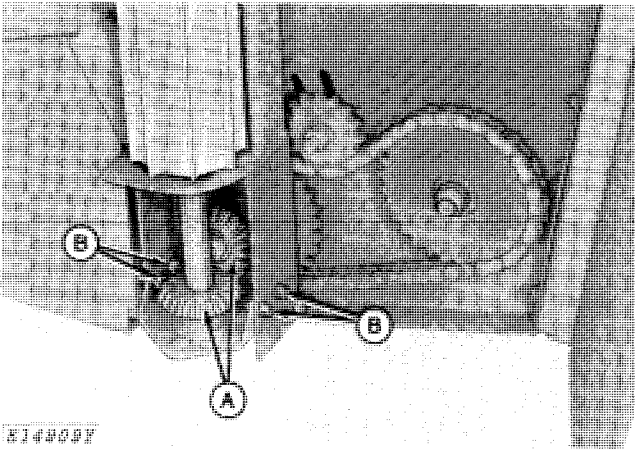

A—18-Tooth Gears B—Adjusting Cap Screws

Fig. 7-Adjusting Gear Backlash

Measure gear backlash (not illustrated). Gear backlash must not exceed 0.004 to 0.025-inch (0.10 to 0.64 mm) when heel of gears is within 1/32-inch (0.79 mm).

Apply a commercially available marking compound to the gear teeth and rotate to allow visual determination of tooth contact.

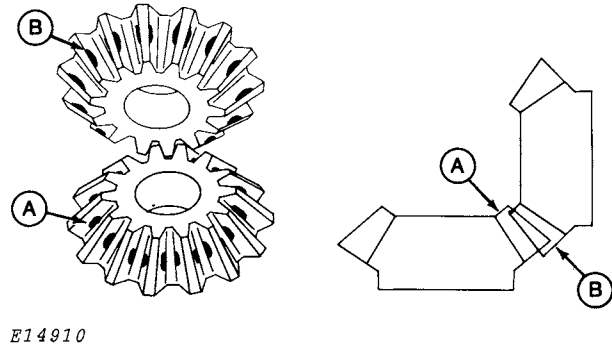

A—High Contact B—Low Contact

Fig. 8-Improper Tooth Contact

Fig. 8 illustrates improper tooth contact pattern and must be corrected by loosening adjusting cap screws (4, Fig. 5) and aligning gears.

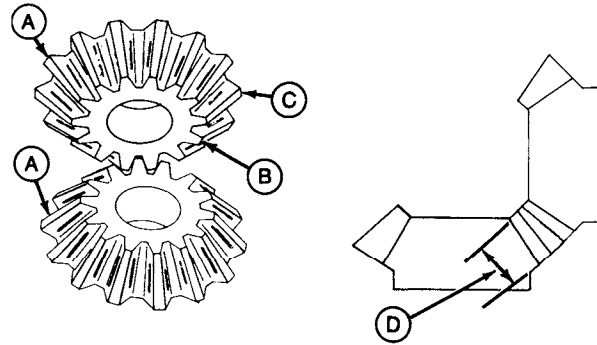

E14911

A—18-Tooth Gears B—Toe C—Heel D—Face Width

Fig. 9-Proper Tooth Contact Pattern

Fig. 9 illustrates proper tooth contact pattern. Additional "fine tuning" can be attained by loosening four adjusting cap screws (B, Fig. 7) and moving lower support vertically or horizontally until proper gear contact is made.

NOTE: 18-Tooth gears (A, Fig. 7) on right-hand side of stalker "float", and will not need adjusting.

Tighten adjusting cap screws securely. Torque lock nut (1, Fig. 5) to 150 ± 20 (210 ± 27 Nm).

See page 39 to adjust row unit drive chain.

<https://www.ebooklibonline.com>

Hello dear friend!

Thank you very much for reading.

Enter the link into your browser.

The full manual is available for immediate download.

<https://www.ebooklibonline.com>