

444C Loader

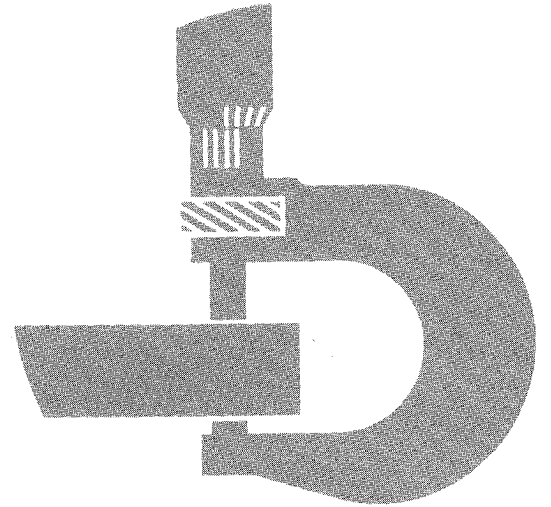

TECHNICAL MANUAL

444C LOADER TECHNICAL MANUAL TM-1227 (FEB-84)

SECTION AND GROUP CONTENTS

SECTION I—GENERAL INFORMATION

- Group I—Contents and Index
- Group II—Introduction and Safety Information
- Group III—General Specifications
- Group IV—Lubrication

SECTION 01 - WHEELS

- Group 0110—Powered Wheels and Fastenings

SECTION 02—AXLES AND SUSPENSION SYSTEMS

- Group 0200—Removal and Installation
- Group 0210—Differential or Bevel Drive
- Group 0225—Input Drive Shafts and U-Joints
- Group 0250—Axle Shafts, Bearings and Reduction Gears
- Group 0260—Hydraulic System

SECTION 03—TRANSMISSION

- Group 0300—Removal and Installation
- Group 0315—Controls
- Group 0325—Input Drive Shafts and U-Joints
- Group 0350—Gears, Shafts, Bearings and Power Shift Clutch
- Group 0360—Hydraulic System

SECTION 04—ENGINE

- Group 0400—Removal and Installation
- Group 0401—Crankshaft and Main Bearings
- Group 0402—Camshaft and Valve Actuating Means
- Group 0403—Connecting Rods and Pistons
- Group 0404—Cylinder Block

SECTION 04—ENGINE—Continued

- Group 0407—Oiling System
- Group 0408—Ventilating System
- Group 0409—Cylinder Head and Valves
- Group 0410—Exhaust Manifold
- Group 0413—Fuel Injection System
- Group 0414—Intake Manifold
- Group 0416—Turbocharger
- Group 0417—Water Pump
- Group 0419—Oil Cooler
- Group 0420—Fuel Filter
- Group 0421—Fuel Transfer Pump
- Group 0422—Starting Motor and Fastenings
- Group 0433—Flywheel, Housing and Fastenings

SECTION 05—ENGINE AUXILIARY SYSTEMS

- Group 0505—Cold Weather Starting Aids
- Group 0510—Cooling Systems
- Group 0515—Speed Controls
- Group 0520—Intake System
- Group 0530—External Exhaust Systems
- Group 0540—Mounting Frame
- Group 0560—External Fuel Supply Systems

SECTION 06—TORQUE CONVERTER

- Group 0651—Turbine, Gears, Shafts and Bearings

Continued on next page

All information, illustrations and specifications contained in this technical manual are based on the latest information available at the time of publication. The right is reserved to make changes at any time without notice. Wherever applicable, specifications and design information are in accordance with SAE and ICED standards.

Copyright© 1984
DEERE & COMPANY
Moline, Illinois
All Rights Reserved
A JOHN DEERE ILLUSTRATION
Previous Edition
Copyright© 1983 Deere & Company
Copyright© 1982 Deere & Company
Copyright© 1980 Deere & Company

T09:1227 01 230982

SECTION AND GROUP CONTENTS—Continued

SECTION 09—STEERING SYSTEM

- Group 0930—Emergency Steering
- Group 0960—Hydraulic System

SECTION 10—SERVICE BRAKES

- Group 1011—Active Elements
- Group 1015—Controls Linkage
- Group 1060—Hydraulic System

SECTION 11—PARKING-EMERGENCY BRAKES

- Group 1111—Active Elements
- Group 1115—Controls Linkage

SECTION 16—ELECTRICAL SYSTEMS

- Group 1671—Batteries, Support and Cables
- Group 1672—Alternator, Regulator and Charging System Wiring
- Group 1673—Lighting System
- Group 1674—Wiring Harness and Switches
- Group 1675—System Controls
- Group 1676—Instruments and Indicators

SECTION 17—FRAME, CHASSIS, OR SUPPORTING STRUCTURE

- Group 1740—Frame Installation
- Group 1746—Frame Bottom Guards
- Group 1749—Chassis Weights

SECTION 18—OPERATOR'S STATION

- Group 1800—Removal and Installation
- Group 1810—Operator Enclosure
- Group 1821—Seat and Seat Belt
- Group 1830—Heating and Air Conditioning

SECTION 19—SHEET METAL AND STYLING

- Group 1910—Hood or Engine Enclosure
- Group 1921—Grille and Grille Housing
- Group 1927—Fenders

SECTION 20—SAFETY, CONVENIENCE AND MISCELLANEOUS

- Group 2002—Mirror
- Group 2004—Horn and Warning Devices
- Group 2006—Cigar Lighter

SECTION 21—MAIN HYDRAULIC SYSTEM

- Group 2160—Hydraulic System

SECTION 31—LOADER

- Group 3102—Buckets
- Group 3115—Controls Linkage
- Group 3140—Frames
- Group 3160—Hydraulic System

SECTION 33—BACKHOE

- Group 3300—Removal and Installation
- Group 3301—Blades, Teeth and Shanks
- Group 3302—Buckets
- Group 3315—Controls Linkage
- Group 3340—Frames
- Group 3360—Hydraulic System

SECTION 90—SYSTEM TESTING

- Group 9005—General Information - Seven Basic Steps of Diagnosis and Testing
- Group 9010—Engine
- Group 9015—Electrical System
- Group 9020—Power Train
- Group 9025—Hydraulic System
- Group 9031—Heating and Air Conditioning

SECTION 99—SPECIAL TOOLS

INDEX

INTRODUCTION AND SAFETY INFORMATION

INTRODUCTION

This technical manual is part of a twin concept of service.

FOS Manuals - for reference.

Technical Manuals - for actual service.

The two kinds of manuals work as a team to give you both the general background and technical details of shop service.

Fundamentals of Service (FOS) Manuals cover basic theory of operation, fundamentals of troubleshooting, general maintenance, and basic types of failures and their causes. FOS Manuals are for training new personnel and for reference by experienced technicians.

Technical Manuals are concise service guides for a specific machine. Technical manuals are on-the-job guides containing only the vital information needed by an experienced service technician.

Some features of this technical manual:

John Deere ILLUSTRATION format emphasizing more detailed pictures and a minimum use of words.

Detailed repair procedures outlined in individual section.

System diagnostic testing detailed in separate section.

Table of contents of all sections at the front of the manual and a listing of all groups and headings at the front of each section.

Special tools and specifications listed at the front of each group they are used in.

Special tools illustrated in numerical order at end of manual.

Alphabetical listing of all major components, specifications, and special tools.

General specifications, lubrication requirements, and a summation of safety rules.

This technical manual was planned and written for you - an experienced service technician. Keep it in a permanent binder in the shop where it is handy. Refer to it whenever in doubt about correct service procedures or specifications.

Using the technical manual as a guide will reduce error and costly delay. It will also assure you the best in finished service work.

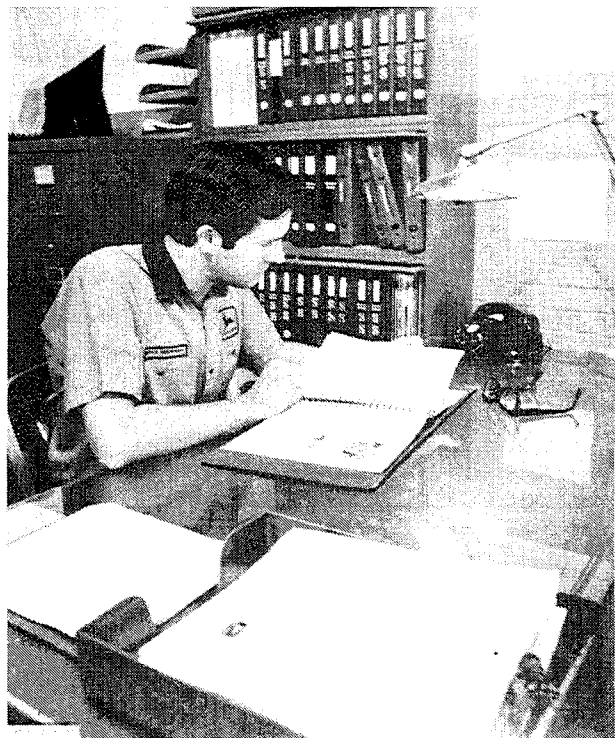

02A-X2253N, X2252N T09:III16 090281

<https://www.ebooklibonline.com>

Hello dear friend!

Thank you very much for reading.

Enter the link into your browser.

The full manual is available for immediate download.

<https://www.ebooklibonline.com>

SAFETY AND YOU



CAUTION: This safety symbol followed by the word "caution" identifies important safety messages in this manual and on the loader or compactor. When you see this symbol, be alert to the possibility of personal injury and carefully read the message that follows.



T27999N

02A:T27999 N T09:1102 160181

Be prepared if an accident or fire should occur. Know where the first aid kit and the fire extinguishers are located - know how to use them.

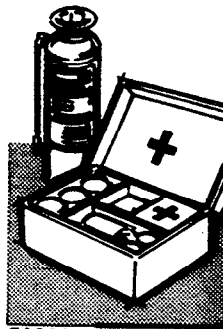

T27504N

02A:T27504 N T09:1103 160181

Wear safety equipment.

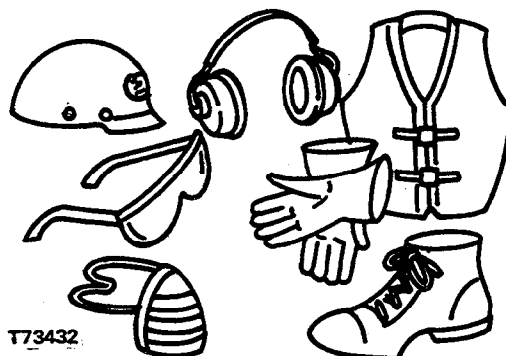

T73432

02A:T73432 T09:1104 160181

Introduction and Safety Information

Wear fairly tight clothing.



T23672

02A:T45672 R T09:1105 160181



CAUTION: Escaping fluid under pressure can have sufficient force to penetrate the skin, causing serious injury. Before disconnecting lines, be sure to relieve pressure. Before applying pressure, be sure connections are tight and lines, pipes and hoses are not damaged. Use a piece of cardboard or wood, rather than hands, to search for leaks.

If injured by escaping fluid, see a doctor at once. Serious infection or reaction can develop if proper medical treatment is not administered immediately.

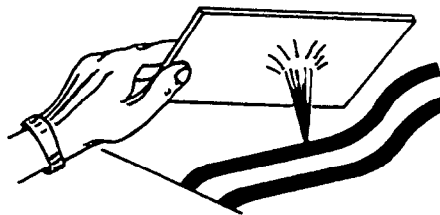

02A:T45794 T09:1117 090281

KEEP SHOP AND STORAGE AREA CLEAN

Maintenance area should be adequately vented.

Keep maintenance area clean and dry.

Store flammable materials in a cool and well-vented area out of reach of unauthorized personnel.



02A:T27508 N T09:1107 160181

FOLLOW SAFE WORKING CONDITIONS

Perform work on equipment only if authorized to do so.

Follow recommended procedures.

Do not service equipment while it is being operated or engine is running.

Always use two service technicians - one, the operator at the controls, the other checking within sight of the operator.

Keep hands away from moving parts.

Support all raised equipment.

Do not work under raised bucket.

Always lower bucket before working on it.

If machine is on an incline, block it securely.

Use hoisting equipment for lifting heavy parts.

Wear safety glasses when drilling, grinding or hammering metal.

Do not use open flame around machine.

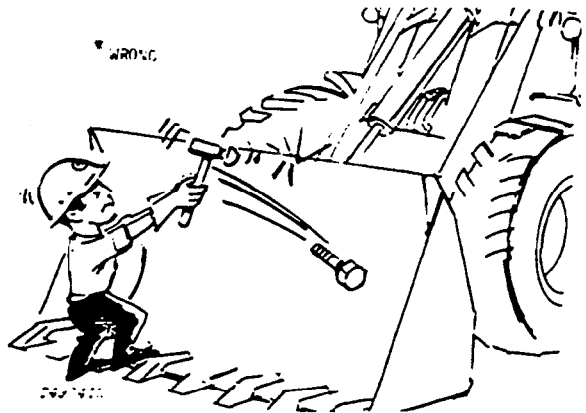

OBSERVE SERVICE PRECAUTIONS

Keep all equipment free of dirt and oil.

Remove oil, grease, mud, ice, or snow from floor of operator's compartment or steps.

Do not remove radiator filler cap until coolant temperature is below the boiling point. Then loosen cap slowly to relieve pressure before removing.

Check exhaust system periodically for excessive leakage.

Relieve hydraulic pressure before working on hydraulic system.

Use the correct test group when checking hydraulic pressure.

Discharge accumulators completely before recharging or servicing.

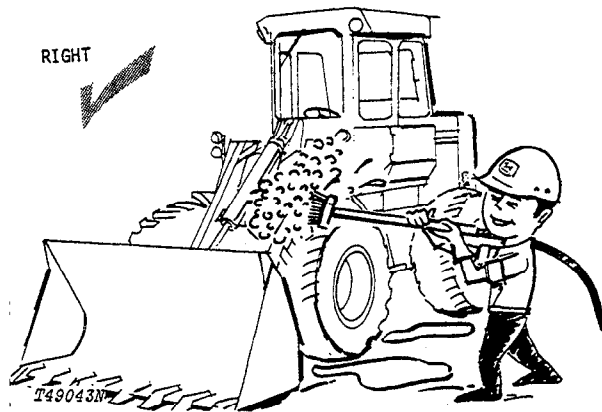

02A:T49043N T09:III14 090281

OBSERVE REPAIR PRECAUTIONS

Relieve hydraulic pressure before working on hydraulic system.

Disconnect batteries before repairing the electrical system or performing a major overhaul.

Securely block bucket before changing cutting edges. Wear gloves when working with sharp edges.

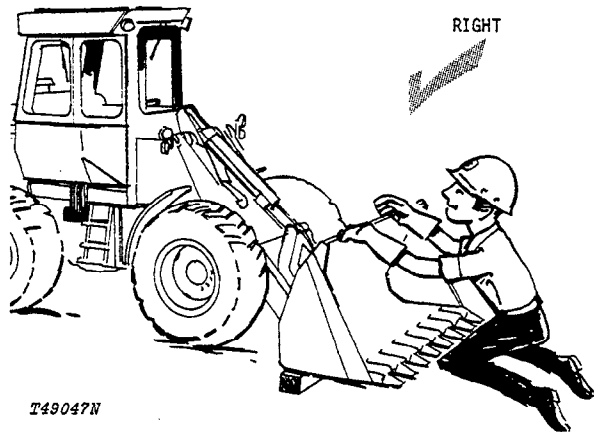

02A:T49047 N T08:III15 090281

CHECK SAFETY EQUIPMENT ON MACHINE

Check that all protective devices (guards, canopies, shields, ROPS, seat belts, etc.) are installed and secured on machine.

Inspect machine carefully for leakage from lines, hoses and fittings.

X WRONG



T32708N

02A:T32708 N T09:III11 190181

AVOID EXPLOSIONS OR FIRE

Do not smoke while refueling.

Do not smoke while handling highly flammable materials.

Shut off engine when refueling.

Use care in refueling if engine is hot.

Use good commercial, nonflammable solvents for cleaning parts.

WRONG

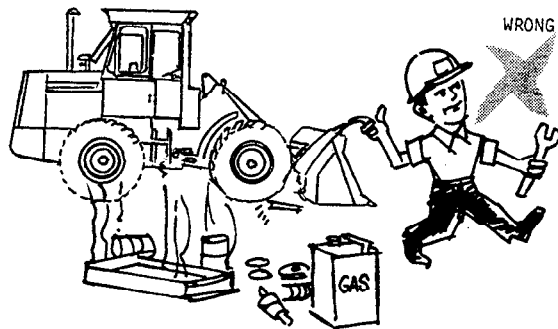

02A:T49038 N T09:III12 190181

OBSERVE BATTERY PRECAUTIONS

Provide adequate ventilation when charging batteries.

Do not place metal objects across posts to check charge.

Do not smoke near battery.

Do not allow sparks or open flame near battery.

WRONG

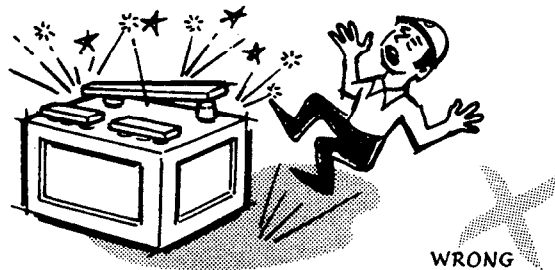

02A:T27505 N T09:III13 190181

General Specifications

Hydraulic Cylinders:	Bore	Stroke
Boom, two	5.25 in. (133 mm)	22.5 in. (571 mm)
Bucket, one	5.25 in. (133 mm)	25.30 in. (643 mm)
Cylinder rods	.Ground, heat-treated, chrome plated, polished.	
Boom and bucket cylinder rods 2.25 in. (57 mm) dia.	

Tires:

15.5-25, 8-ply-rating, L2 loader tread
 15.5-25, 12-ply-rating, L2 loader tread
 13.00-24, 8 ply-rating, G2 grader tread
 17.50-25, 12-ply rating, L2 loader tread

Wheel Treads:

Front and rear 70 in. (1.78 m)

Capacities	U.S.	Imp.	Liters
Cooling system	.. 25 qt.	20.8 qt.	23.7
Fuel tank 40 gal.	33.3 gal.	151.4
Crankcase 11 qt.	9.2 qt.	10.4
Crankcase, in- cluding filter 12 qt.	10.0 qt.	11.4
Transmission case and filters	.. 40 qt.	33.3 qt.	37.9
Front and Rear differential	.. 17 qt.	14.2 qt.	16.1
Loader hydraulic sump 56 qt.	46.7 qt.	53.0

Additional Standard Equipment:

Adjustable cushioned seat with belt
 Engine side shields
 Front fenders
 Gauges
 Transmission oil temperature
 Transmission oil pressure
 Fuel
 Coolant temperature
 Engine oil pressure
 Electric hourmeter
 Voltmeter
 Instrument panel warning lights
 Parking brake
 Hydraulic filter bypass
 Loader hydraulic system indicator light

Key switch
 Pushbutton safety start
 Cigar lighter
 Transistorized voltage regulator
 Engine side shields w/locks
 Transmission disconnect
 Work lights, front flood, rear
 combination tail and brake lights
 ROPS cab
 Heater/defroster or heater/defroster and pressurizer
 Front and rear windshield wipers
 Windshield washer
 Dome light
 Instrument panel cover w/lock
 Horn
 Fuel filter
 Automatic return to dig
 Rear bottom guard
 Hand grips
 Fixed drawbar
 Antifreeze
 Precleaner
 Cold weather starting aid
 Articulation transport lock
 Low-maintenance batteries

Special Equipment:

ROPS canopy
 Adjustable suspension seat, vinyl or cloth
 Heater for canopy
 For ROPS cab:
 Air conditioner
 Radio—AM
 Mirrors
 Reverse warning alarm
 Triple hydraulic valve for loader
 Bucket teeth
 Auxiliary bottom guard
 License plate bracket
 Automatic boom height control
 SMV emblem
 Auxiliary cutting edges
 Flashing and turn signal lights
 Rear-axle disconnect
 Hydraulic front differential lock
 Auxiliary spill guard
 Altitude-compensating turbocharger
 Emergency steering

T09:III122 290782

General Specifications

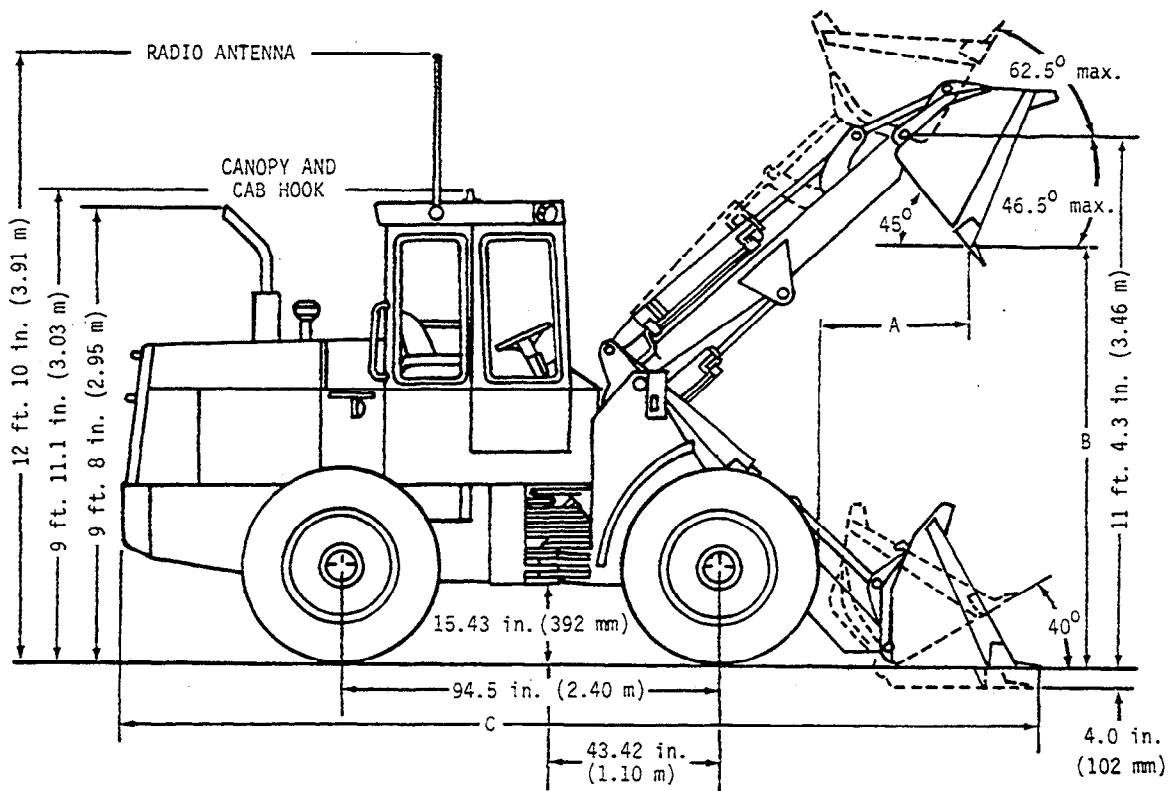

BUCKETS	DIMENSIONS		
	A	B	C
1-1/2 cu. yd. (1.15 m ³)	32.9 in. (836 mm)	9 ft. 1.2 in. (2.77 m)	19 ft. (5.80 m)
1-3/4 cu. yd. (1.34 m ³)	34.33 in. (872 mm)	8 ft. 11.6 in. (2.73 m)	19 ft. 2.4 in. (5.85 m)
3 cu. yd. (2.29 m ³)	41.83 in. (1062 mm)	8 ft. 4.1 in. (2.54 m)	20 ft. 1 in. (6.12 m)
1-1/2 cu. yd. multipurpose (1.15 m ³)	33.5 in. (847 mm)	8 ft. 5.7 in. (2.58 m)	19 ft. 11.0 in. (6.07 m)

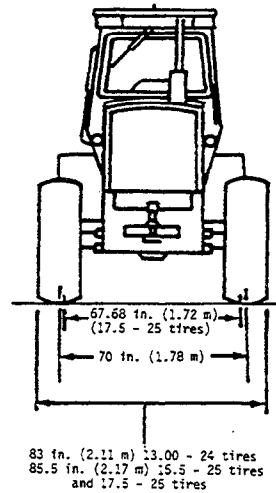

02A:779070 77907109JH03 B 200181

General Specifications

OPERATING INFORMATION	BUCKET			
	General purpose	General purpose	Light materials	Multipurpose
Capacity, heaped, SAE	1-1/2 cu. yd. (1.15 m ³)	1-3/4 cu. yd. (1.34 m ³)	3 cu. yd. (2.29 m ³)	1-1/2 cu. yd. (1.15 m ³)
Capacity, struck, SAE	1.22 cu. yd. (0.93 m ³)	1.42 cu. yd. (1.09 m ³)	2.49 cu. yd. (1.90 m ³)	1.23 cu. yd. (0.94 m ³)
Bucket width	88 in. (2.23 m)	92 in. (2.34 m)	96 in. (2.44 m)	88 in. (2.23 m)
Bucket weight	1190 lb. (540 kg)	1470 lb. (667 kg)	1920 lb. (871 kg)	2122 lb. (962 kg)
Breakout force, J732C SAE Standard using bucket hinge pin as pivot point	16,985 lb. (75.5 kN) (7704 kg)	15,680 lb.* (69.74 kN) (7112 kg)	11,245 lb. (52.02 kN) (5101 kg)	14,620 lb. (65.03 kN) (6632 kg)
Tipping load, straight max. reach	12,985 lb. (5890 kg)	14,035 lb.* (6306 kg)	12,230 lb. (5547 kg)	10,840 lb. (4917 kg)
Tipping load, 40-deg. full turn SAE	11,253 lb. (5105 kg)	12,135 lb. (5504 kg)	10,500 lb. (4763 kg)	9270 lb. (4205 kg)
Tipping load, 35-deg. turn	11,650 lb. (5280 kg)	12,570 lb. (5700 kg)	10,890 lb. (4940 kg)	9630 lb. (4940 kg)
Circle diameter or turning clearance outside the bucket	32 ft. (9.76 m)	32 ft. 2 in. (9.80 m)	33 ft. 3 in. (10.13 m)	32 ft. 6 in. (9.91 m)
Loader operating weight	18,315 lb. (8308 kg)	19,535 lb.* (8861 kg)	19,045 lb. (8639 kg)	19,251 lb. (8732 kg)

*Operating weight and specification with 1-3/4 cu. yd. (1.34 m³) bucket includes 75 % fill of CaCl₂ solution in rear tires.

**SAE operating load specification for wheel loaders will not exceed 50% of the SAE full turn tipping load.

Adjustments to operating weights and tipping loads for 1-1/2 cu. yd. (1.15 m ³) General Purpose Bucket			
Add (+) or deduct (-) lb. (kg) as indicated for loader equipped with:	Loader Operating Weight	Tipping Load Straight	Tipping Load, 40-deg. Full Turn, SAE
Less ROPS cab	-715 lb. (324 kg)	-600 lb. (272 kg)	-560 lb. (254 kg)
ROPS canopy in lieu of ROPS cab	-275 lb. (125 kg)	-215 lb. (98 kg)	-205 lb. (93 kg)
13.00-24, 8-ply-rating, grader tread tires	+380 lb. (172 kg)	+250 lb. (113 kg)	-215 lb. (98 kg)
17.50-25, 12-ply-rating, loader tread tires	+645 lb. (292 kg)	+420 lb. (190 kg)	+365 lb. (166 kg)
Air conditioning	+70 lb. (32 kg)	+125 lb. (57 kg)	+105 lb. (48 kg)
Auxiliary cutting edge	+120 lb. (54 kg)	-155 lb. (70 kg)	-155 lb. (70 kg)
Auxiliary spill guard	+110 lb. (50 kg)	-75 lb. (34 kg)	-75 lb. (34 kg)

1093104 B 210181

General Specifications

Maximum recommended material weight, lb. per cu. yd. (kg/cm ³)				
All standard equipment and 15.5-25, 8-ply-rating tires	1-1/2 cu. yd. (1.15 m ³)	1-3/4 cu. yd.* (1.34 m ³)	3 cu. yd. (2.29 m ³)	1-1/2 cu. yd. (1.15 m ³)
	General purpose	General purpose	Light materials	Multipurpose
Loader less cab or canopy	3135 (1860)	2910 (1727)	1460 (866)	2570 (1525)
Loader with canopy	3240 (1922)	3000 (1780)	1510 (896)	2660 (1578)
Loader with cab	3300 (1958)	3050 (1810)	1540 (914)	2720 (1614)

*Standard operating weight plus 75% fill of CaCl₂ solution in rear tires.

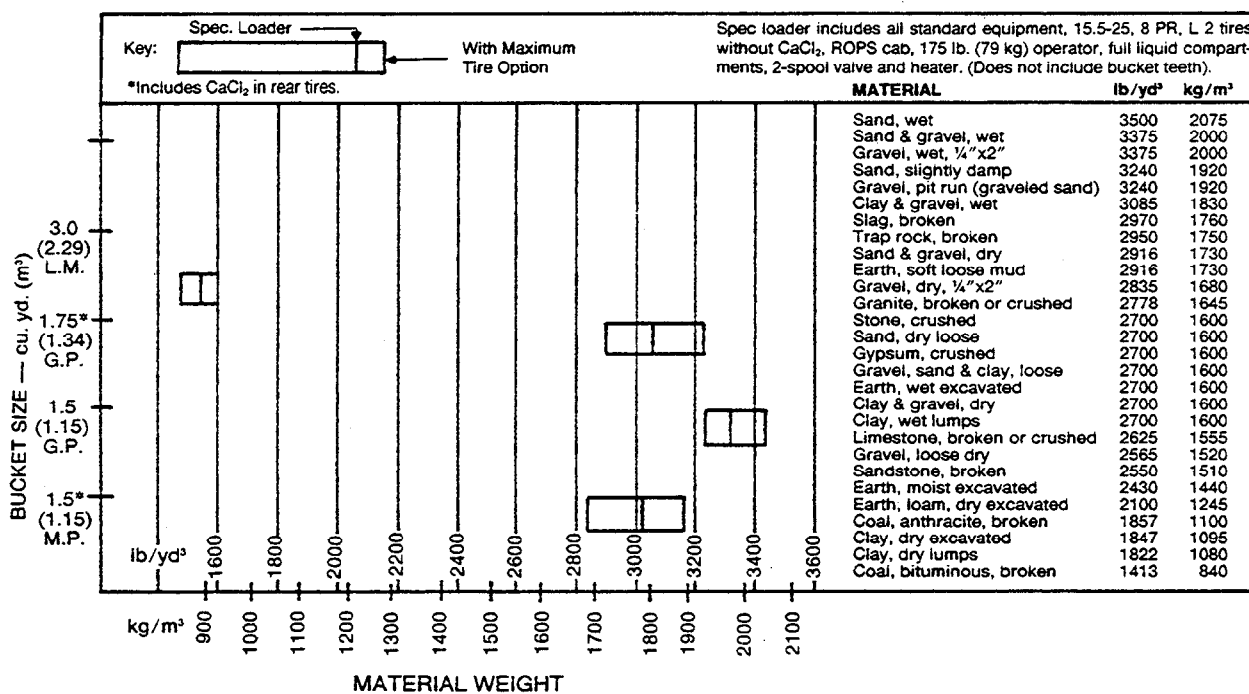

02A:779072 T09:0005 B 210181

General Specifications

GENERAL INFORMATION

Refer to the periodic service chart located on the inside of the left engine side shield when servicing the loader.

Your operator's manual contains more detailed information on servicing the loader.

PERIODIC SERVICES

REFER TO OPERATOR'S MANUAL FOR MORE DETAILED INFORMATION

INTERVAL	COMPONENTS	SERVICE POINTS	DESCRIPTION OF SERVICE	RECOMMENDED MEASUREMENT	LUBRICANT SERVICE MATERIAL	
10 OR DAILY	1 AIR CLEANER	1 Job 1 Job	CHECK LEVEL OF ACCUMULATED MATERIAL SEE LABEL ON AIR CLEANER	AS INDICATED ON BOWL		
	2 FRESH GREASE	1	CHECK LEVELS PER OPERATOR'S MANUAL	BETWEEN MARKS ON DIPSTICK	OPERATOR'S MANUAL SEE CHART AND/OR OPERATOR'S MANUAL	
	3 LOADER RESERVOIR	1	CHECK LEVELS PER OPERATOR'S MANUAL	BETWEEN MARKS ON DIPSTICK	OPERATOR'S MANUAL	
	4 FUEL FILTER	1 Job 1 Job 1 Job	CHECK FOR SEDIMENT	BETWEEN MARKS ON DIPSTICK OR 1/2 INCH	OPERATOR'S MANUAL	
	5 TRANSMISSION	1	CHECK OIL LEVEL	SEE OPERATOR'S MANUAL		
	6 FRONT HOIST AND SUPPORT BEARING	1	LUBRICATE GREASE FITTINGS	ADD GREASE UNTIL FRESH GREASE ESCAPES AROUND SEAL	SEE SFC	
	7 FRAME WELD POINTS	3	LUBRICATE GREASE FITTINGS	3 OR 3 INJECTIONS	SEE SFC	
	8 DISC/LIFTED REAR SEAL	3	LUBRICATE GREASE FITTINGS	10 INJECTIONS	SEE SFC	
	9 LOADER BOW & CYLINDER POINTS	4	LUBRICATE GREASE FITTINGS	SEE OPERATOR'S MANUAL	SEE SFC	
	10 CAR RECIRCULATING AIR FILTER	1	CLEAN AS REQUIRED			
30	11 STEERING CYLINDER PIVOT PINN	4	LUBRICATE GREASE FITTINGS	3 OR 3 INJECTIONS	SEE SFC	
	12 ALTERNATOR & FAN BELT AND CONDITION BELT	3	CHECK TENSION	SEE OPERATOR'S MANUAL		
	13 BUSH & PINNALS, WELLS AND TRANSMISSION TO FRONT DIFFERENTIAL TELESCOPING SHIELD	4	LUBRICATE GREASE FITTINGS LOW PRESSURE LUBRICATION OF GREASE FITTING	1 OR 2 INJECTIONS	SEE SFC	
	14 ENGINE CRANK CASE OIL	1	DRAIN & REFILL	JOHN DEERE 100, 110, 115, 120, 125, 130, 135, 140, 145, 150, 155, 160, 165, 170, 175, 180, 185, 190, 195, 200, 205, 210, 215, 220, 225, 230, 235, 240, 245, 250, 255, 260, 265, 270, 275, 280, 285, 290, 295, 300, 305, 310, 315, 320, 325, 330, 335, 340, 345, 350, 355, 360, 365, 370, 375, 380, 385, 390, 395, 400, 405, 410, 415, 420, 425, 430, 435, 440, 445, 450, 455, 460, 465, 470, 475, 480, 485, 490, 495, 500, 505, 510, 515, 520, 525, 530, 535, 540, 545, 550, 555, 560, 565, 570, 575, 580, 585, 590, 595, 600, 605, 610, 615, 620, 625, 630, 635, 640, 645, 650, 655, 660, 665, 670, 675, 680, 685, 690, 695, 700, 705, 710, 715, 720, 725, 730, 735, 740, 745, 750, 755, 760, 765, 770, 775, 780, 785, 790, 795, 800, 805, 810, 815, 820, 825, 830, 835, 840, 845, 850, 855, 860, 865, 870, 875, 880, 885, 890, 895, 900, 905, 910, 915, 920, 925, 930, 935, 940, 945, 950, 955, 960, 965, 970, 975, 980, 985, 990, 995, 1000	OPERATOR'S MANUAL OPERATOR'S MANUAL OPERATOR'S MANUAL	
	15 CRANK CASE OIL FILTER	1 Job 1 Job 1 Job	REPLACE			
	16 FUEL SYSTEM	1	DRAIN WATER FROM FUEL CLEAN STRAINER			
	17 CAR FRESH AIR FILTER	1	CLEAN			
	18 MUNCTION PUMP SEDIMENT BOWL AND SCREEN	1 Job	CHECK, REMOVE, CLEAN AND REINSTALL AS REQUIRED			
	50	19 ELECTRICAL SYSTEM HOSES & CONNECTIONS	4	CHECK FOR LEAKS		
		20 AIR CLEANER HOSES & CONNECTIONS	4 Job 4 Job 4 Job	CHECK FOR LEAKS		
21 HYDRAULIC STRAINER		2	REMOVE, CLEAN, REINSTALL			
22 FRONT & REAR DIFFERENTIALS		2	CHECK OIL LEVELS	1/2 INCH WITH CHECK PLUG	OPERATOR'S MANUAL	
23 FUEL TANK DRAIN VALVE		1	REMOVE, CLEAN & REINSTALL			
24 AXLE BEARINGS		4	METAL GREASE FITTINGS & LUBRICATE	10 TO 20 INJECTIONS	SEE SFC	
25 TRANSMISSION TO DIFFERENTIAL DRIVE SHAFT		7	LOW PRESSURE LUBRICATION OF GREASE FITTINGS	UNTIL FRESH GREASE ESCAPES	SEE SFC	
26 BATTERIES		3 Job 2 Job 3 Job	CHECK ELECTROLYTE LEVELS CHECK TERMINALS FOR CORROSION	UNTIL FRESH GREASE ESCAPES BOTTOM OF FILLER NECK	OPERATOR'S MANUAL OPERATOR'S MANUAL	
27 LOADER RESERVOIR RETURN		1 Job 1 Job 1 Job	REPLACE FILTERS		JOHN DEERE FILTERS	
28 FUEL FILTERS		1 Job 1 Job 1 Job	REPLACE FILTERS		JOHN DEERE FILTERS	
100	29 AIR CLEANER	1	REPLACE BOTH ELEMENTS		OPERATOR'S MANUAL	
	30 TRANSMISSION	1	DRAIN AND REFILL	SEE OPERATOR'S MANUAL	OPERATOR'S MANUAL	
	31 TRANSMISSION & STEERING FILTERS	1	REPLACE FILTERS	SEE OPERATOR'S MANUAL	OPERATOR'S MANUAL	
	32 CHAMBERLAIN HEAT FUEL	1	CLEAN			
	33 UNRECALIBRATED ENGINE TO TRANSMISSION	2	LOW PRESSURE LUBRICATION OF GREASE FITTING	UNTIL FRESH GREASE ESCAPES	SEE SFC	
	34 ENGINE VALVE LASH	12	CHECK AND ADJUST	SEE SFC	SEE SFC	
	35 ENGINE SPECIES	3	CHECK AND ADJUST	SEE SFC	SEE SFC	
	36 FRONT & REAR DIFFERENTIALS	2	DRAIN & REFILL	SEE OPERATOR'S MANUAL	OPERATOR'S MANUAL	
	37 LOADER RESERVOIR	1	DRAIN FRESH & REFILL	SEE OPERATOR'S MANUAL	OPERATOR'S MANUAL	

WPS MULTIPURPOSE GREASE

REWORK THIS SERVICE ONLY ON EVERY 100 HOURS WHEN OPERATED IN SOFT SOIL OR WATER
 CHANGE GREASE IN OIL & FILTERS AFTER FIRST 100 HOURS OF USE WHEN LOADER IS USED QUINQUA
 PREVENT AIR TRAPS BATTERIES ON LOW WPT (DIPIC) CHARGE ON AFTER EVERY 100 HOURS OF OPERATION OR EVERY 3 WEEKS OF STORAGE
 OPERATOR'S MANUAL

WPS FUEL FILTERS

100 LITERS (27 GALLONS) WITH FILTER CHARGE

AIR TEMP	ENGINE OIL		WATER
	WASH OIL	WASH OIL	
ADD TO	WASH OIL	WASH OIL	WASH OIL
30°F (-1°C)	SEE SFC	SEE SFC	NOT RECOMMENDED
30°F TO 100°F (-1°C TO 38°C)	SEE SFC	SEE SFC	SEE SFC
100°F TO 150°F (38°C TO 66°C)	SEE SFC	SEE SFC	SEE SFC

LUBRICANTS

Engine Oils

Use John Deere TORQ-GUARD SUPREME® engine oil.

Use John Deere TORQ-GARD SUPREME SAE 10W-20 oil or equivalent during the first 100 hours of operation for break-in.

Oils other than John Deere TORQ-GARD SUPREME must have one of the following specifications.

Single Viscosity Oils

API Service CD/SC
MIL-L-2104C
Series 3

Multi-Viscosity Oils

API Service CC/SE
MIL-L-46152

Oil and Air Temperatures

Air Temperature	John Deere	Other Oils	
	TORQ-GARD SUPREME Oil	Single Viscosity Oil	Multi-Viscosity Oil
Above 32°F (0°C)	SAE 30	SAE 30	Not recommended
-10°F to 32°F (-23°C to 0°C)	SAE 10W-20	SAE 10W	SAE 10W-30
Below -10°F (-23°C)	SAE 5W-20	SAE 5W	SAE 5W-20

If you use SAE 5W-20 or SAE 5W oil, your engine may use more oil. Check the oil level regularly.

Transmission, Steering, and Brake System Oil

Above -20°F (-29°C), use John Deere Hydraulic Oil Type J14C, or an equivalent.

If temperatures are below -20° (-29°C), use John Deere HY-GARD Winter Grade Transmission and Hydraulic Oil (J20B).

John Deere HY-GARD Winter Grade Transmission and Hydraulic Oil (J20B) must not be used at sustained temperatures above 32°F (0°C).

Hydraulic and Differential Oils

Use John Deere HY-GARD® Transmission and Hydraulic Oil (J20B) or equivalent.

Grease

Use a SAE Multi-Purpose Grease containing 3-5% molybdenum disulfide for all grease fittings except axle bearings (Preferred).

You may also use:

- John Deere Multi-Purpose Grease or equivalent.
- SAE Multi-Purpose Grease

Use John Deere High Temperature Grease for axle bearings.

You may also use:

- SAE Multi-Purpose High Temperature Grease for temperatures above 150°F (66°C).

NOTE: John Deere High Temperature Grease may be used for all grease applications on the loader.

Storing and Handling Lubricants

Store lubricants in clean containers in an area protected from dust, moisture and other contamination.

When handling lubricants, use clean container.

Section 01 WHEELS

CONTENTS

GROUP 0110 - POWERED WHEELS AND FASTENINGS

Special Tools	0110-01
Specifications	
Loader Wheel	0110-01
Loader Wheel Assembly	
Remove	0110-01
Install	0110-03

T09:010002 270782

Group 0110

POWERED WHEELS AND FASTENINGS

SPECIAL TOOLS

NOTE: Order tools from your SERVICE-GARD™ Catalog, unless otherwise indicated.

Number	Name	Use
D-05019ST	Heavy Duty Wheel Lift	Remove and install wheels
D-24206WK	Shop Stand	Supports the unit while removing wheels

T09:011001 231280

LOADER WHEEL SPECIFICATION

1. Cap screw torque ... (410 ± 40 N.m) 300 ± 30 lb-ft

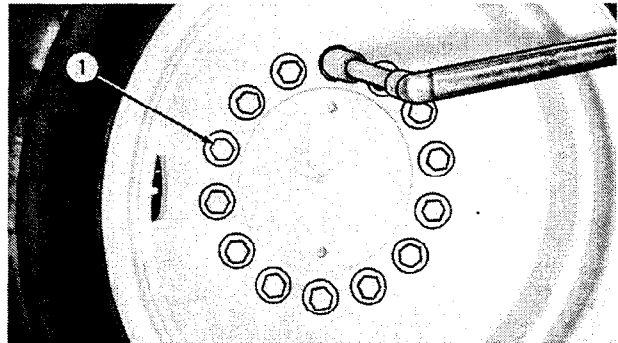

17A:T79309 T09:011020 030381

REMOVE LOADER WHEEL ASSEMBLY

⚠ CAUTION: A loader wheel weighs approximately (807 kg) 1780 lbs.

1. Loosen cap screws before lifting off the ground.

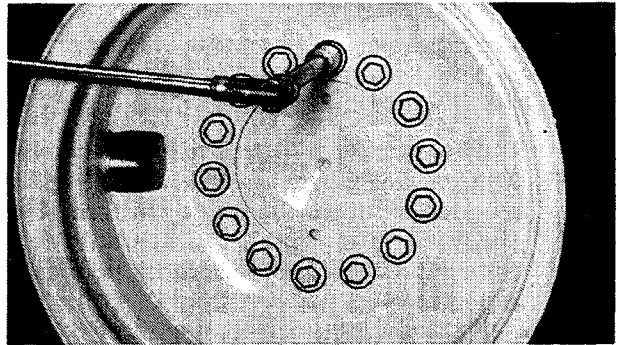

17A:T79310 T09:011021 030381

2. Lift the wheel off the ground using a service jack or hoist of at least (9000 kg) 10-Ton capacity.
3. Support the axle housing using a shop stand of at least (9000 kg) 10-Ton capacity.



17A:T79311 T09:011022 030381

4. Support wheel with the D-05019ST Wheel Lift (1). Fasten safety chain around the upper portion of tire.
5. Remove the cap screws (2). Pull wheel assembly away from axle.

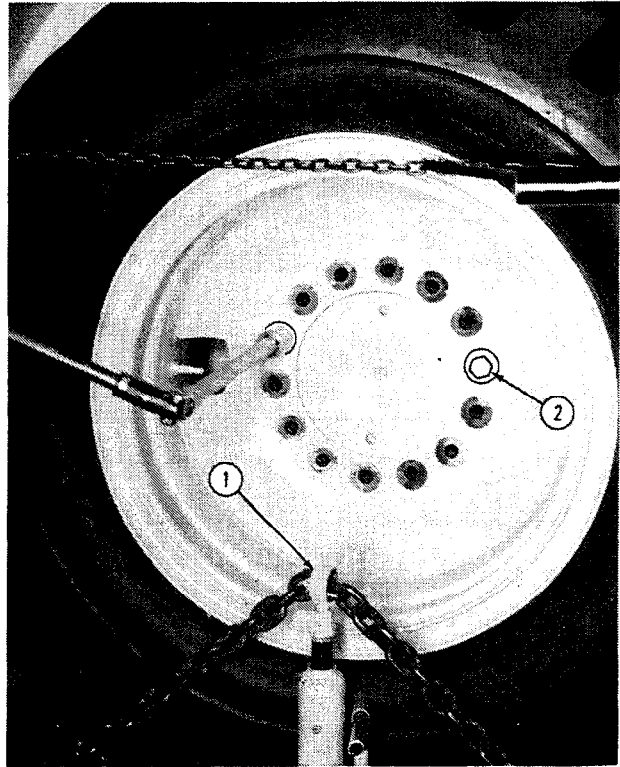

17A:T79312 T09:011023 030381

REMOVE LOADER TIRE

1. The tire can be removed without removing the wheel from the loader. See the John Deere Off-The-Road Tire Maintenance Manual to remove the tire from the wheel.

CAUTION: Failure to follow proper procedures when demounting a tire from a wheel or rim can produce an explosion which may result in serious bodily injury. DO NOT attempt to demount a tire unless you have the proper equipment and experience to perform the job safely. Have it done by a qualified tire repair service.

T09:011006 231280

2. Always completely deflate the tire by removing the valve core (1) from valve before attempting any demounting operation. Check the valve stem by running a probe through it to make sure the valve stem is not plugged. Remove valve nut (2).

3. Inspect all parts for damage; replace parts as necessary.

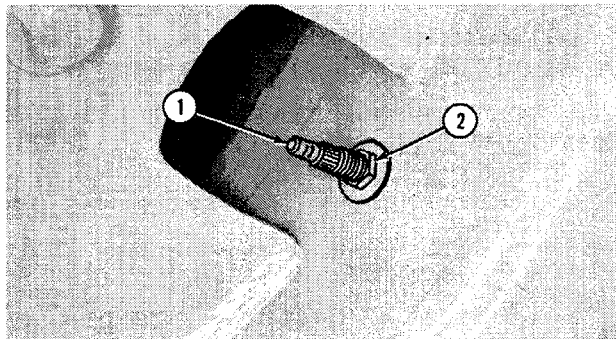

17A:T79313 T09:011024 030381

INSTALL LOADER TIRE



CAUTION: Failure to follow proper procedures when mounting a tire on a wheel or rim, can produce an explosion which may result in serious bodily injury. **DO NOT** attempt to mount a tire unless you have the proper equipment and experience to perform the job safely. Have it done by a qualified tire repair service.

NOTE: See the John Deere Off-The-Road Tire Maintenance Manual to mount the tire on the wheel.

1. Make sure all parts are clean and free from rust or grease before assembly.

T09:011008 231280

2. To prevent slipping of the wheel under load, the inside and outside of wheel (1) must be free of paint, rust, oil, grease, dirt or other foreign material before installation.

3. Instal valve stem (2) in rim base and tighten valve core housing finger tight.

4. Put John Deere Non-Soap Lubricating Grease, or an equivalent, on threads of pipe cap (if equipped). Install pipe cap on valve stem shield.



CAUTION: Serious bodily injury can occur from explosion when mounting and inflating tires if safe procedures are not followed.

5. Before mounting tire on rim, add soap lubricant to beads of the tire and O-ring (3).

6. Before adding air to tire, make sure the back ring (4) fits tight against the base all around the circumference.

7. Clear the area of all persons.

8. Use a pressure-regulating valve with clip-on chuck and extension hose long enough to allow you to stand well to one side and NOT in front of the assembly while inflating.

9. Use only recommended air pressure. Pressure over this limit can cause explosion.

10. Add air until side flange of tire slides out against the back ring.

11. Before completely inflating tire, again make certain the back ring is in its proper groove completely around the rim.

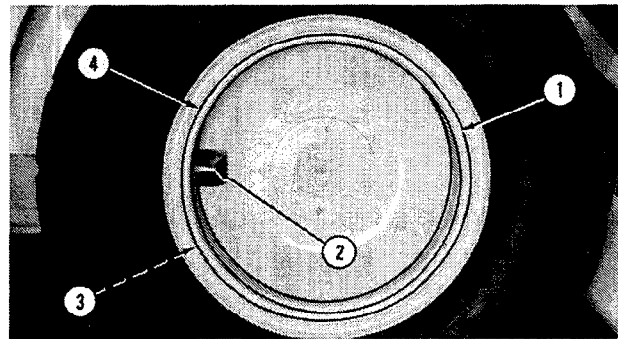

17A:T79314 T09:011026 030881

Powered Wheels and Fastenings

Tire Size	Type	Ply Rating	Operating Pressure
13.00-24	G2	8	(344.8 kPa) (3.4 bar) 50 psi
15.5-25	L2	8	(310.3 kPa) (3.1 bar) 45 psi
15.5-25	L2	12	(379.2 kPa) (3.7 bar) 55 psi
17.5-25*	L2	12	(379.2 kPa) (3.7 bar) 55 psi

*Use with log loader

12. Check air pressure in all tires with an accurate gauge having (6.89 kPa) (0.07 bar) 1 psi graduations. Be sure that tire pressures are equal for all four tires.

T09:011026 030381

INSTALL LOADER WHEEL ASSEMBLY

1. Thoroughly clean the cap screws, washers and the tapped holes in the flanged axle. Use compressed air to dry all parts and tapped holes.
2. Install special studs (1) in the flanged axle. The special studs are used as guides for installing loader wheels.
3. Use a D-05019ST Wheel Lift (2) to install the wheel.

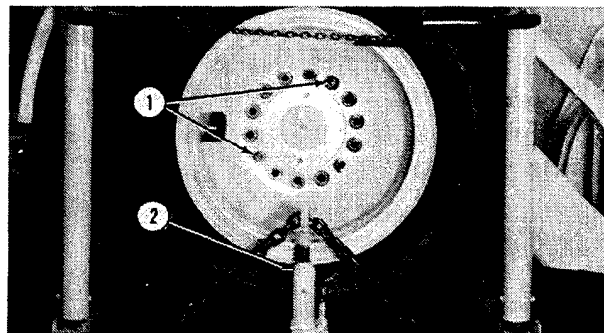

17A:779315 T09:011027 030381

4. Install and tighten cap screws to (203 ± 20 N.m) 150 ± 15 lb-ft.
5. Lower the loader to the ground.

IMPORTANT: If a power wrench is used, be sure that the cap screws are engaged to prevent stripping. Operate the wrench slowly to prevent thread damage.

6. Cross tighten the cap screws to (410 ± 40 N.m) 300 ± 30 lb-ft.

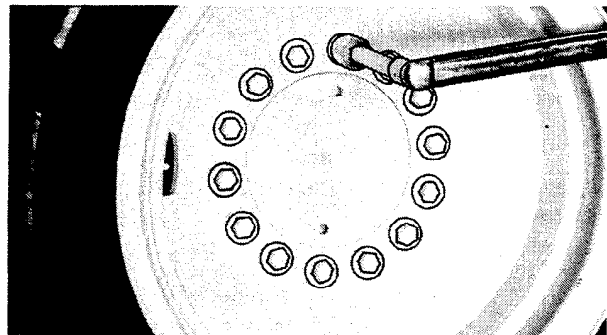

17A:779316 T09:011028 030381

Section 02

AXLES AND SUSPENSION SYSTEMS

CONTENTS

GROUP 0200 - REMOVAL AND INSTALLATION

Special Tools	0200-03
Specifications	
Front Differential and Axle	0200-03
Rear Differential and Axle	0200-03
Front Axle and Differential Assembly	
Remove	0200-05
Install	0200-08
Rear Axle and Differential Assembly	
Remove	0200-10
Install	0200-13
Adjust	0200-13

GROUP 0210 - DIFFERENTIAL OR BEVEL DRIVE

Special Tools	0210-01
Specifications	
Rear Oscillating Support	0210-01
Bevel Pinion Shaft Rolling Drag	
Torque	0210-02
Bevel Pinion Shaft Nut	0210-02
Input Quill Oil Seal	0210-02
Input Quill	0210-02
Ring Gear Bushing	0210-03
Right Housing Cover	0210-03
Left Housing Cover	0210-03
Differential Housing Preload	0210-04
Differential Housing Rolling	
Drag Torque	0210-04
Differential Housing Backlash	0210-04
Differential Bearing Quill	0210-05
Differential Lock Line Connections	0210-05
Differential Case	0210-05
Differential Case Cover	0210-05
Front Oscillating Support	
Remove	0210-06
Disassemble	0210-06
Assemble	0210-07
Install	0210-10
Rear Oscillating Support	
Remove	0210-11
Disassemble	0210-11
Assemble	0210-12
Install	0210-13

GROUP 0210 - DIFFERENTIAL OR BEVEL DRIVE - Continued

Differential Cover	
Remove	0210-14
Disassemble	0210-14
Assemble	0210-47
Install	0210-47
Differential Input Quill	
Remove	0210-15
Disassemble	0210-15
Assemble	0210-19
Adjust	
Cone Point	0210-20
Pinion Shaft Preload	0210-23
Install	0210-09
Differential Assembly	
Remove	0210-25
Disassemble	0210-28
Assemble	0210-31
Install	0210-41
Adjust	
Differential Preload	0210-41
Differential Backlash	0210-42
Test	0210-44

GROUP 0225 - INPUT DRIVE SHAFTS AND U-JOINTS

Specifications	
Double Universal Joint	0225-01
Universal Joint Drive Shaft	0225-01
Support Bearing	0225-02
Rear Differential Drive Line	0225-02
Double Universal Joint	
Remove	0225-04
Disassemble and Inspect	0225-04
Assemble	0225-05
Install	0225-08
Support Bearing	
Remove	0225-05
Install	0225-07
Universal Joint Drive Shaft	
Remove	0225-06
Disassemble	0225-06
Assemble	0225-07
Install	0225-07

Continued on next page

T09;0200 66 130982

CONTENTS - Continued

GROUP 0225 - INPUT DRIVE SHAFT AND U-JOINTS - Continued

Rear Differential Drive Line	
Remove	0225-09
Disassemble	0225-09
Assemble	0225-10
Install	0225-11

GROUP 0250 - AXLE SHAFT, BEARINGS, REDUCTION GEARS

Special Tools	0250-01
Specifications	
Axle Shaft	0250-01
Axle Housing	0250-01
Axle Housing	
Remove	0250-02
Disassemble	0250-02
Assemble	0250-11
Adjust	
Axle Shaft	0250-12
Install	0250-14
Planet Pinion Carrier	
Remove	0250-04
Disassemble	0250-05
Assemble	0250-06

GROUP 0260 - HYDRAULIC SYSTEM

Special Tools	0260-01
Specifications	
Differential Lock Pressure	
Regulating Valve	0260-01
Differential Lock Pressure Regulating	
Valve	
Remove	0260-02
Install	0260-03
Differential Lock Solenoid Valve	
Remove	0260-05
Install	0260-06

Group 0200
REMOVAL AND INSTALLATION

SPECIAL TOOLS

NOTE: Order tools from your SERVICE-GARD™ Catalog, unless otherwise indicated.

Number	Name	Use
D-01182AA or D-24206WK	Shop Stands	Supports the unit while removing differentials

T09;020001 171280

FRONT DIFFERENTIAL AND AXLE SPECIFICATIONS

1. Nuts torque (600 ± 60 N·m) 445 ± 45 lb-ft

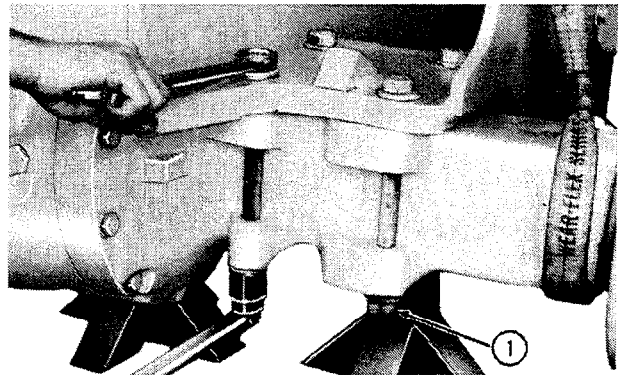

06A;T77458 T09;020002 030682

2. Cap screws torque (68 ± 7 N·m) 50 ± 5 lb-ft

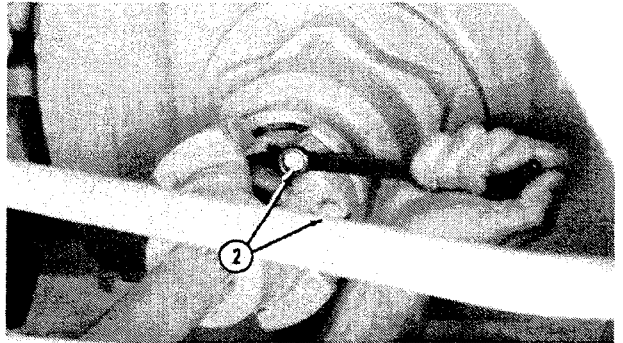

06A;T77400 T09;020056 090281

REAR DIFFERENTIAL AND AXLE SPECIFICATIONS

1. Install shims to give an end play clearance of (0.03 to 0.46 mm) 0.001 to 0.018 in.

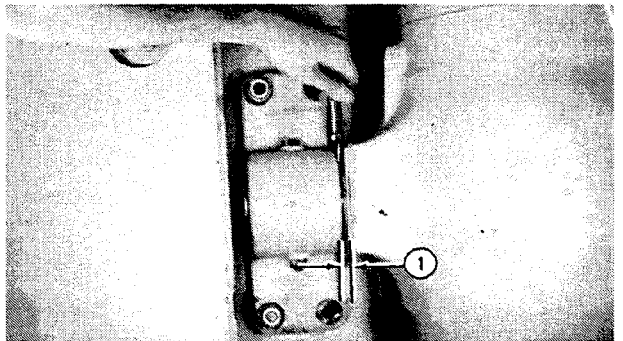

06A;T77394 T09;020004 030682

Removal and Installation

2. Cap screws and nuts torque

5/8 in.(325 N·m) 240 lb-ft
20 mm (680 ± 68 N·m) 500 ± 50 lb-ft

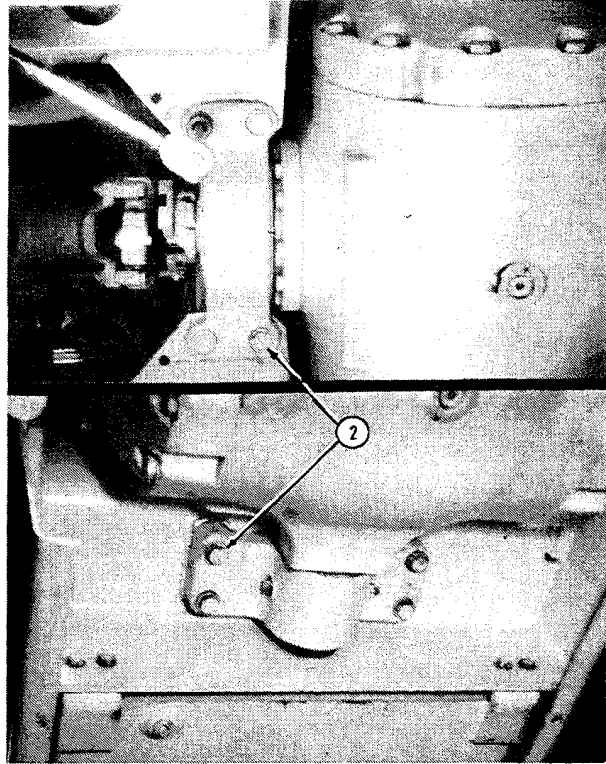

06A:T77459 T09:020005 030682

3. Cap screws torque (68 ± 7 N·m) 50 ± 5 lb-ft.

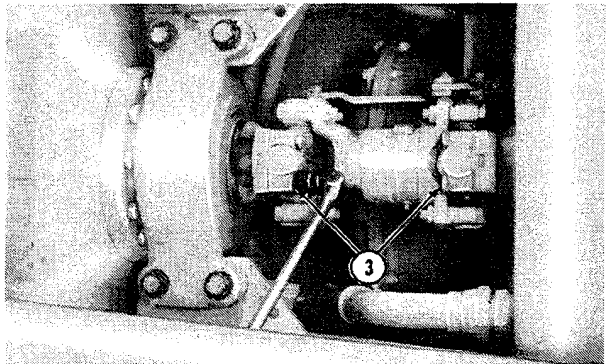

06A:T77402 T09:020057 110281

FRONT AXLE AND DIFFERENTIAL ASSEMBLY - PUT SHOP STANDS UNDER LOADER FRAME

1. Lift loader boom as high as possible. Put a support with a rated capacity of approximately (1772 kg) 3900 lbs. under bucket and boom.
2. Stop the engine.
3. Operate the steering valve, brake valve and loader control valve to release hydraulic pressure in the systems. Put loader control lever into float position.
4. Install lock bar (1).

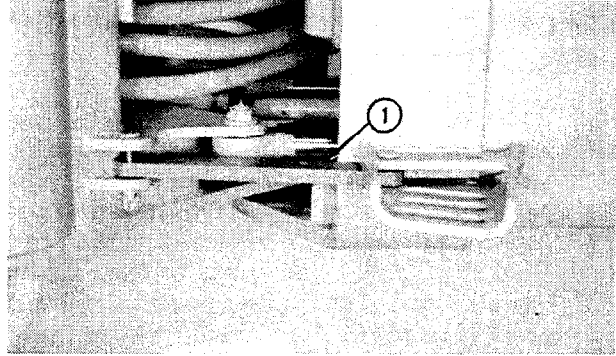

06A.T75019 T09:020007 221280

5. Disconnect battery ground cables (1).

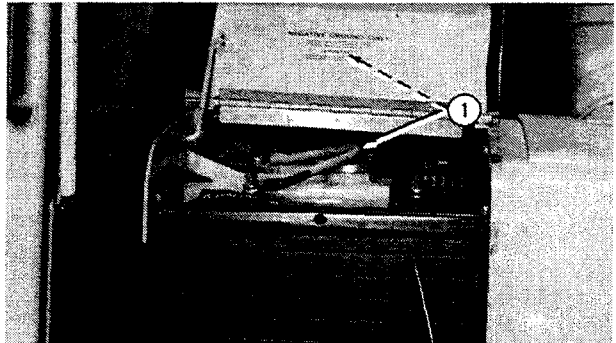

06A.T76321 T09:020056 110281

6. Remove bottom guard (if equipped).
7. Fasten a chain hoist (1) to the loader frame hooks and lift the front of the machine.
8. Put D-00182AA (shown) or D-24206WK Shop Stands (2) under loader frame. Lower machine onto shop stands.
9. Remove wheels (Group 0110).

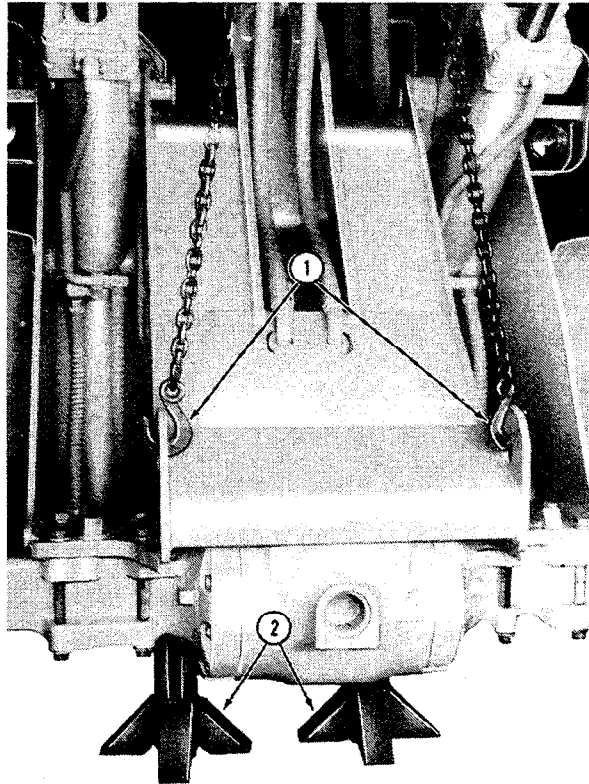

06A.T77460 T09:020059 110281

DISCONNECT HYDRAULIC LINES AND DRIVE SHAFT

⚠ CAUTION: Escaping hydraulic oil under pressure can have sufficient force to penetrate the skin, causing serious injury. Before disconnecting lines, be sure to relieve pressure. Before applying pressure, be sure connections are tight and lines, pipes, and hoses are not damaged. Use a piece of cardboard or wood, rather than hands, to search for leaks.

If injured by escaping oil, see a doctor at once. Serious infection or reaction can develop if proper medical treatment is not administered immediately.

1. Disconnect hydraulic brake line (1) and differential lock return hose (2).

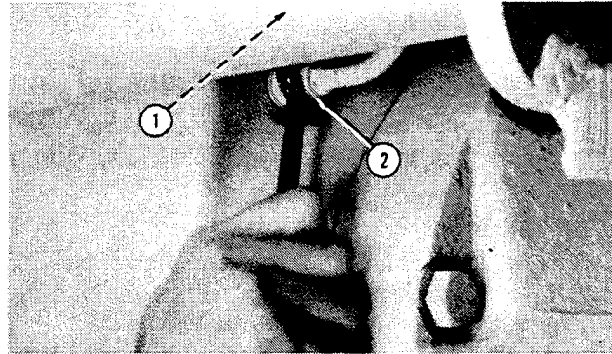

06A;T77461 T09;020011 240383

2. Disconnect differential lock inlet line (1).
3. Close all openings with caps and plugs to keep dirt from entering the hydraulic system.
4. Remove four cap screws (2) to disconnect drive shaft from input quill.

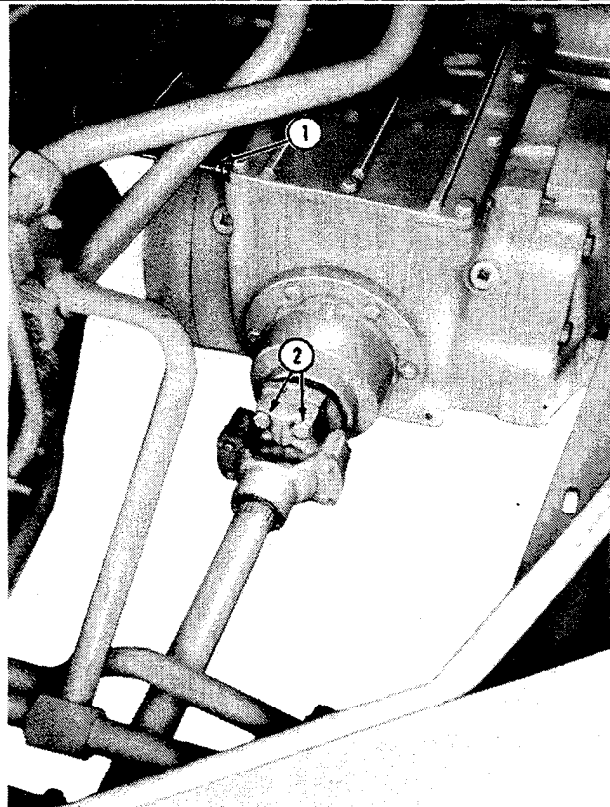

06A;T75216 T09;020012 240283



Suggest:

If the above button click is invalid.

Please download this document

first, and then click the above link

to download the complete manual.

Thank you so much for reading

Removal and Installation

LOWER DIFFERENTIAL AND AXLE ASSEMBLY

1. Remove drain plug to drain approximately (22.5 L) 6 gal. of oil from differential.
2. Put a lifting strap (1) around each axle housing.

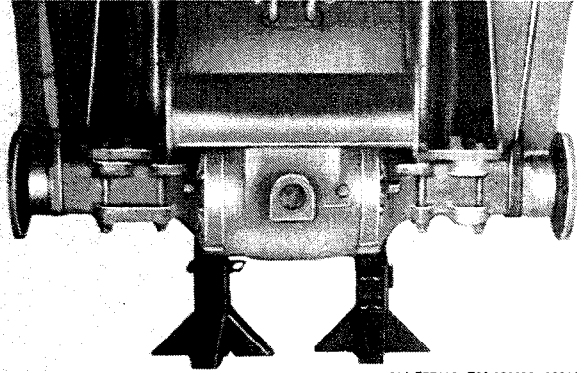

06A:T77462 T09:020013 030682

3. Put tension on straps and remove eight bolts and nuts.

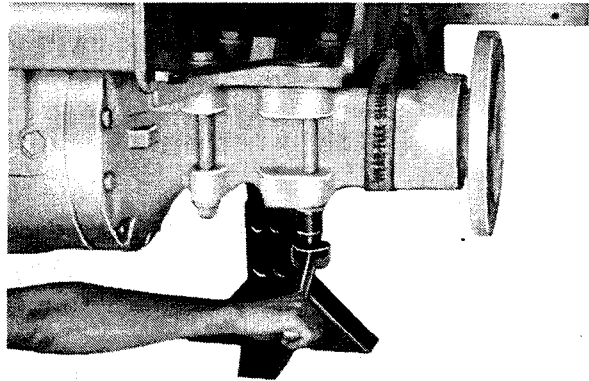

06A:T77463 T09:020014 171280

4. Lower axle and differential as an assembly.

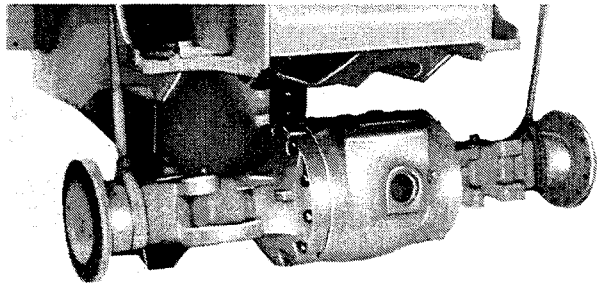

06A:T77464 T09:020015 171280

<https://www.ebooklibonline.com>

Hello dear friend!

Thank you very much for reading.

Enter the link into your browser.

The full manual is available for immediate download.

<https://www.ebooklibonline.com>