

John Deere 440, 440 Series-A and 440-B Skidders

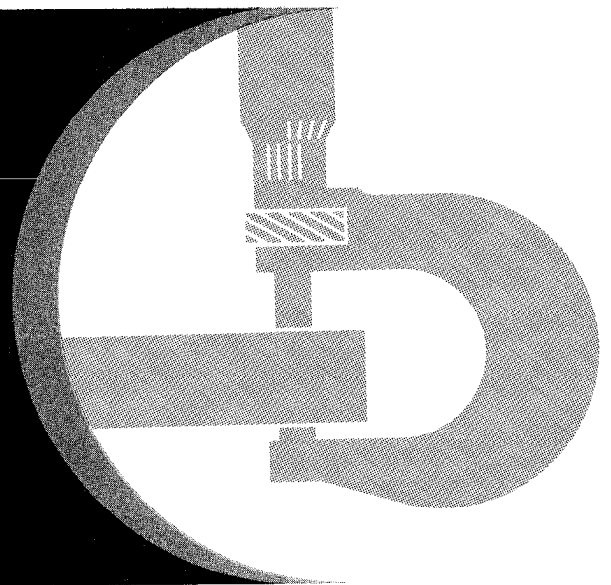

TECHNICAL MANUAL

John Deere Davenport Works
TM-1009

Litho in U.S.A.

JD440, JD440 SERIES-A, and JD440-B SKIDDERS

TECHNICAL MANUAL

TM-1009 (Mar-80)

CONTENTS

Section 10—GENERAL

- Group 5 Specifications
- Group 10 Predelivery, Delivery and After-Sales Service
- Group 15 Tune-Up and Adjustment
- Group 20 Lubrication
- Group 25 Separation

Section 20—ENGINE

- Group 5 Diagnosis
- Group 10 Basic Engine
- Group 15 Engine Lubrication
- Group 20 Governor and Speed Control Linkage
- Group 25 Engine Cooling
- Group 30 Specifications and Special Tools

Section 30—FUEL SYSTEM

- Group 5 System Diagnosis
- Group 10 Tank, Transfer Pump, and Filters,
- Group 15 Air Intake System
- Group 20 Carburetor
- Group 25 Fuel Injection Pumps
- Fuel Injection Nozzles (See SM-2045)

Section 40—ELECTRICAL SYSTEM

- Group 5 Wiring Diagrams
- Group 10 Charging System
- Group 15 Ignition System
- Group 20 Starting Motors
- Group 25 Gauges
- Group 30 Specifications and Special Tools

Section 50—POWER TRAIN

- Group 5 System Diagnosis
- Group 10 Clutches
- Group 15 Drive Shafts
- Group 20 Power Shift Transmission
- Group 25 Syncro-Range Transmission
- Group 30 Axle Assemblies
- Group 35 Differentials
- Group 40 Auxiliary Power System (Syncro-Range Transmission)

Section 60—STEERING AND BRAKES (See Section 70)

Section 70—HYDRAULIC SYSTEM

- Group 5 General Information, Testing, and Diagnosis
- Group 10 Hydraulic Pump
- Group 15 Filters, Valves, Oil Cooler, and Accumulators
- Group 20 Steering System
- Group 25 Brake System
- Group 30 Selective Control System
- Group 35 Couplers and Cylinders

Section 80—MISCELLANEOUS COMPONENTS

- Group 5 Winch System
- Group 10 Frames
- Group 15 Specifications and Special Tools

INDEX

The specifications and design information contained in this manual were correct at the time it was printed. It is John Deere's policy to continually improve and update our machines. Therefore, the specifications and design information are subject to change without notice. Wherever applicable, specifications and design information are in accordance with SAE and IEMC standards.

INTRODUCTION

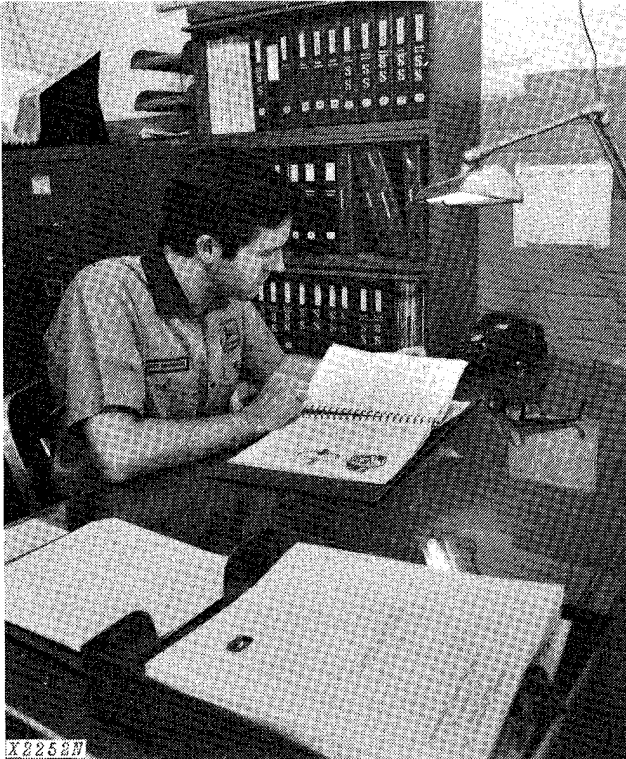

Use FOS Manuals for Reference

This technical manual is part of a twin concept of service:

- **FOS Manuals**—for reference
- **Technical Manuals**—for actual service

The two kinds of manuals work as a team to give you both the general background and technical details of shop service.

Fundamentals of Service (FOS) Manuals cover basic theory of operation, *fundamentals* of trouble shooting, *general* maintenance, and *basic* types of failures and their causes. FOS Manuals are for training new personnel and for reference by experienced service technicians.

Technical Manuals are concise service guides for a specific machine. Technical Manuals are on-the-job guides containing only the vital information needed by an experienced service technician.



When a service technician should refer to a FOS Manual for more information, a FOS symbol like the one at the left is used in the TM to identify the reference.

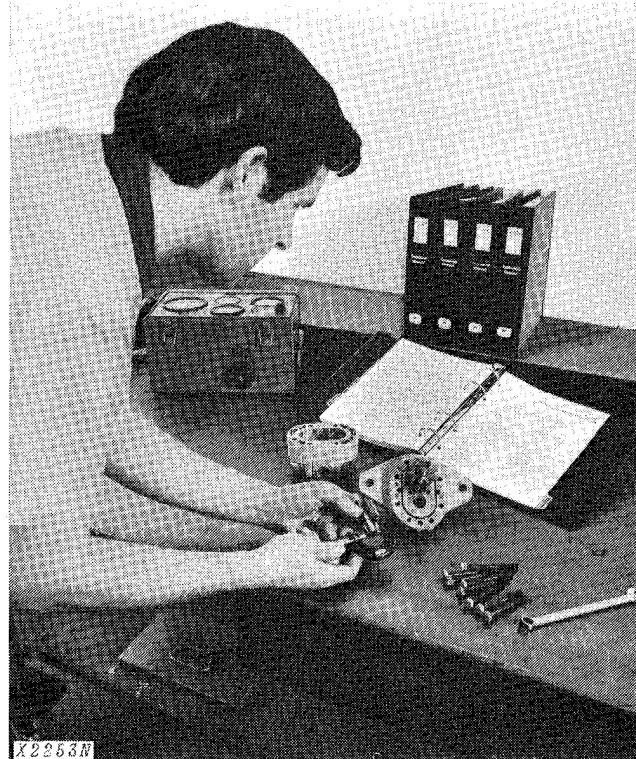

Use Technical Manuals for Actual Service

Some features of this technical manual:

- *Table of contents at front of manual*
- *Exploded views showing parts relationship*
- *Photos showing service techniques*
- *Specifications grouped for easy reference*

This technical manual was planned and written for you—an experienced service technician. Keep it in a permanent binder in the shop where it is handy. Refer to it whenever in doubt about correct service procedures or specifications.

Using the technical manual as a guide will reduce error and costly delay. It will also assure you the best in finished service work.



This safety alert symbol identifies important safety messages in this manual. When you see this symbol, be alert to the possibility of personal injury and carefully read the message that follows.

<https://www.ebooklibonline.com>

Hello dear friend!

Thank you very much for reading.

Enter the link into your browser.

The full manual is available for immediate download.

<https://www.ebooklibonline.com>

**COMPLETE PAGE LISTING
 WITH LATEST DATE LINES**

1,2	(Mar-80)	30-5-1,2	(Jan-72)	40-30-1,2	(Mar-80)
3,4	(Mar-80)			40-30-3,4	(Jan-74)
		30-10-1,2	(Oct-72)	40-30-5,6	(Apr-74)
10-5-1,2	(Oct-72)	30-10-3,4	(Feb-75)	40-30-7,8	((Mar-80)
10-5-3,4	(Apr-72)	30-10-5,6	(Mar-80)	40-30-9,10	(Apr-74)
				50-5-1,2	(Mar-80)
10-10-1,2	(Jan-72)	30-15-1,2	(Mar-80)	50-5-3,4	(Mar-80)
10-10-3,4	(Jan-72)	30-15-3,4	(Jan-72)		
10-10-5,6	(Jan-72)	30-15-5,6	(Mar-80)	50-10-1,2	(Mar-80)
		30-15-7,8	(Mar-80)	50-10-3,4	(Mar-80)
10-15-1,2	(Jan-72)			50-10-5,6	(Feb-73)
10-15-3,4	(Jan-72)	30-20-1,2	(Aug-69)	50-10-7,8	(Mar-80)
		30-20-3,4	(Aug-69)		
10-20-1,2	(Feb-75)	30-20-5,6	(Mar-80)	50-15-1,2	(Feb-75)
				50-15-3,4	(Mar-80)
10-25-1,2	(Mar-80)	30-25-1,2	(Mar-80)	50-15-5,6	(Mar-80)
10-25-3,4	(Oct-70)	30-25-3,4	(Jan-72)	50-20-1,2	(Jul-68)
10-25-5,6	(Oct-70)	30-25-5,6	(Aug-69)	50-20-3,4	(Oct-70)
10-25-7,8	(Oct-70)	30-25-7,8	(Mar-80)	50-20-5,6	(Aug-73)
10-25-9,10	(Mar-80)	30-25-9,10	(Mar-80)	50-20-7,8	(Aug-73)
				50-20-9,10	(Jul-68)
20-5-1,2	(Mar-80)	40-5-1,2	(Mar-80)	50-20-11,12	(Jul-68)
		40-5-3,4	(Jul-68)	50-20-13,14	(Mar-80)
20-10-1,2	(Mar-80)	40-5-5,6	(Jul-68)	50-20-15,16	(Mar-80)
20-10-3,4	(Mar-80)	40-5-7,8	(Jul-68)	50-20-17,18	(Mar-80)
20-10-5,6	(Mar-80)	40-5-9,10	(Jul-68)	50-20-19,20	(Mar-80)
20-10-7,8	(Mar-80)	40-5-11,12	(Mar-80)	50-20-21,22	(Mar-80)
20-10-9,10	(Mar-80)	40-5-13,14	(Mar-80)	50-20-23,24	(Mar-80)
20-10-11,12	(Mar-80)	40-5-15,16	(Jan-74)	50-20-25,26	(Mar-80)
20-10-13,14	(Mar-80)			50-20-27,28	(Mar-80)
20-10-15,16	(Mar-80)	40-10-1,2	(Jan-72)	50-20-29,30	(Mar-80)
20-10-17,18	(Mar-80)	40-10-3,4	(Jan-72)	50-20-31,32	(Mar-80)
20-10-19,20	(Mar-80)	40-10-5,6	(Jan-72)	50-20-33,34	(Mar-80)
		40-10-7,8	(Jan-72)	50-20-35,36	(Mar-80)
20-15-1,2	(Mar-80)	40-10-9,10	(Jan-72)	50-20-37,38	(Mar-80)
20-15-3,4	(Mar-80)	40-10-11,12	(Jan-74)	50-20-39,40	(Mar-80)
20-15-5,6	(Mar-80)	40-10-13,14	(Jan-74)	50-20-41,42	(Mar-80)
		40-10-15,16	(Jan-74)	50-20-43,44	(Mar-80)
20-20-1,2	(Jul-68)	40-10-17,18	(Aug-73)	50-20-45,46	(Mar-80)
20-20-3,4	(Jul-68)	40-10-19,20	(Aug-73)		
20-20-5,6	(Oct-70)	40-10-21,22	(Jan-74)	50-25-1,2	(Jul-68)
20-20-7,8	(Aug-69)			50-25-3,4	(Mar-80)
		40-15-1,2	(Aug-73)	50-25-5,6	(Mar-80)
20-25-1,2	(May-73)	40-15-3,4	(Jan-72)	50-25-7,8	(Mar-80)
20-25-3,4	(May-73)			50-25-9,10	(Mar-80)
		40-20-1,2	(Mar-80)	50-25-11,12	(Oct-70)
20-30-1,2	(Mar-80)	40-20-3,4	(Jul-74)	50-25-13,14	(Oct-70)
20-30-3,4	(Mar-80)	40-20-5,6	(Jan-72)	50-25-15,16	(Oct-70)
20-30-5,6	(Mar-80)	40-20-7,8	(Mar-80)	50-25-17,18	(Oct-70)
20-30-7,8	(Mar-80)			50-25-19,20	(Feb-73)
20-30-9,10	(Mar-80)	40-25-1,2	(Jan-72)	50-25-21,22	(Feb-75)
				50-25-23,24	(Mar-80)

| Vertical lines indicate pages included with this revision.

Shifters and controls, syncro-range transmission	50-25-4	Specifications (Continued):	
Skidder adjustment	10-15-3	Steering system	70-20-12
Solenoid switch, starting motor	40-20-5	Transmission, power shift	50-20-38
Special tools:		Transmission, syncro-range	50-25-20
Air intake system	30-15-7	Winch	80-15-1
Axle assemblies	50-30-2	Speed control linkage	20-20-4
Carburetor	30-20-5	Standard torque chart	10-25-9
Charging system	40-30-2	Start safety switch	40-20-7
Clutch assembly	50-10-4	Starting motor	40-20-1
Cooling system	20-30-10	Stator, enclosed alternator	40-10-14,40-10-17
Couplers and cylinders	70-35-6	Stator, open alternator	40-10-5
Differentials	50-35-10	Steering system (hydraulic)	70-20-1
Disconnect clutch	50-10-8	Stop remote cylinder	70-35-3
Engine	20-30-7	Stop remote cylinder bleeding	70-35-4
Fuel injection pumps	30-25-10	Storage lubricants	10-20-2
Governor and speed control linkage	20-30-9	Storage, temporary	10-10-1
Hydraulic components	70-15-11	Syncro-range transmission	50-25-1
Hydraulic pump	70-10-7		
Hydraulic system	70-15-12	T	
Ignition system	40-30-6	Temporary storage	10-10-1
Lubrication system	20-30-8	Thermostat	20-25-3
Selective control valve (Early Units)	70-30-7	Timing distributor	30-25-5,40-15-4
Selective control valve (Later Units)	70-30-15	Timing fuel injection pumps	30-25-2
Separation	10-25-10	Timing gear train	20-10-18
Starting motor	40-30-7	Torque chart, standard	10-25-9
Steering system	70-20-13	Transmission hydraulic oil	10-20-2
Transmission, power shift	50-20-41	Transmission oil filter	70-15-1
Transmission, syncro range	50-25-22	Transmission, power shift	50-20-1
Winch	80-15-3	Transmission, syncro-range	50-25-1
Specifications:			
Air intake system	30-15-6	V	
Batteries	40-30-1	Valve, brake	70-25-3
Carburetor	30-20-5	Valve, differential lock control	50-35-7
Charging system	40-30-2	Valve, hydraulic oil cooler bypass	70-15-5
Clutch assembly	50-10-4	Valve, hydraulic pressure control	70-15-3
Cooling system	20-30-10	Valve, hydraulic relief	70-15-4
Couplers and cylinders	70-35-6	Valve lift check	20-10-10
Differentials	50-35-9	Valve, oil pressure regulating	20-15-1,20-15-3
Disconnect clutch	50-10-8	Valve rotators	20-10-2
Engine	20-30-1	Valve springs	20-10-2
Fuel injection pumps	30-25-8	Valve tappet clearance adjustment	20-10-3
Fuel system	30-10-5	Valves, engine	20-10-2
General	10-5-1	Valves, hydraulic pump	70-10-2,70-10-4
Governor and speed control linkage	20-30-9	Valves, power shift transmission ..	50-20-7,50-20-24
Hydraulic components	70-15-10	Valves, refacing	20-10-2
Hydraulic pump	70-10-6	Valves, selective control	70-30-1
Hydraulic system	70-15-11	Valves, steering system	70-20-1,70-20-6, 70-20-10
Ignition system	40-30-5	Valves, syncro range transmission	50-25-1,50-25-12
Lighting and accessory circuits	40-30-8		
Lubrication system	20-30-8	W	
Selective control valve (Early Units)	70-30-7	Water pump, engine	20-25-1
Selective control valve (Later Units)	70-30-15	Winch	80-5-1
Separation	10-25-9	Winch pump	80-5-17
Starting motor	40-30-6	Wiring diagrams	40-5-2

Section 10 GENERAL

CONTENTS OF THIS SECTION

	Page		Page
GROUP 5-SPECIFICATIONS		GROUP 20-LUBRICATION—Continued	
Machine Specifications	5-1	Transmission-Hydraulic Oil	20-2
Dimensions	5-4	Greases	20-2
GROUP 10-PREDELIVERY, DELIVERY, AND AFTER-SALES SERVICE		GROUP 25-SEPARATION	
Predelivery Service	10-1	Removing and Installing	
Delivery Service	10-3	Engine and Equipment Frames	25-1
After Sales Services	10-3	Engine	25-2
GROUP 15-TUNE-UP AND ADJUSTMENT		Clutch Housing and Cowl (Syncro-Range) (Direct-Drive)	25-3
Preliminary Engine Testing	15-1	Upper Cowl (Power Shift)	25-4
Engine Tune-Up	15-1	Syncro-Range Transmission (Direct Drive)	25-5
Final Engine Testing	15-3	Power Shift Transmission	25-6
Skidder Adjustment	15-3	Axle Housing and Differential	25-7
GROUP 20-LUBRICATION		Adjusting Front Axle End Play	25-8
Lubrication Chart	20-1	Specifications	25-9
Engine Lubricating Oils	20-2	Tools	25-9

Group 5 SPECIFICATIONS

	JD440		JD440 Series-A and JD440-B	
	Diesel	Gasoline	Diesel	
ENGINE				
Flywheel horsepower (observed) at 2500 rpm.	59.0	59.0	70	
Torque (ft-lbs) (observed) (nominal)	145.0@1300 rpm	145.0@1300 rpm	173@1500 rpm	
Number of cylinders	4	4	4	
Bore and stroke, inches	3.86 x 4.33	3.86 x 3.86	4.02 x 4.33	
Displacement in cubic inches	202.0	180.0	219.0	
Compression ratio	16.3 to 1	7.5 to 1	16.7 to 1	
N.A.C.C. or A.M.A. horsepower rating				
for tax purposes	23.84	23.84	23.84	
Firing order	1, 3, 4, 2	1, 3, 4, 2	1, 3, 4, 2	
Slow idle (rpm)	800	800	800	
Fast idle (rpm)	2650	2700	2650	
Working speed range (rpm)	1500 to 2500	1500 to 2500	1500 to 2500	
Governed speed range (rpm)	800 to 2650	800 to 2700	800 to 2500	

ELECTRICAL SYSTEM

Battery voltage nominal 12 volts
 Battery specific gravity (corrected to 80°F.) (full charge) 1.260
 Battery terminal grounded Negative
 Alternator regulation Voltage regulator

SYNCRANGE TRANSMISSION (Direct-Drive)

Type - Constant mesh with 8 forward and 4 reverse speeds (3 reverse speeds on JD440 Skidders). Four shift stations. Synchronized shifting within stations except reverse.

Clutch - 11 or 12-inch, dry-type, ceramic-faced, foot operated (early models). Ceramic button disc (later models).

POWER SHIFT TRANSMISSION (440-A and 440-B)

Type - Planetary, hydraulically actuated wet disk clutches and brakes. 8 forward and 4 reverse speeds hydraulically shifted and controlled by a single lever.

Disconnect Clutch - 12-inch, dry-type clutch operated by a hand lever (as a starting aid).

TRAVEL SPEEDS (MPH)

(with 18.4-26 Tires - no slippage)

Gear	1500 rpm		2500 rpm	
	Syncro-Range	Power Shift	Syncro-Range	Power Shift
1	1.2	0.9	2.0	1.5
2	1.8	1.3	3.1	2.2
3	2.4	2.0	4.0	3.4
4	3.1	2.6	5.2	4.4
5	3.8	3.4	6.4	5.6
6	5.1	4.4	8.5	7.3
7	6.4	5.8	10.6	9.7
8	10.2	9.7	16.9	16.1
1st Reverse	1.2	1.0	2.0	1.7
2nd Reverse	1.8	1.5	3.1	2.4
3rd Reverse	3.1	2.3	5.2	3.8
4th Reverse	5.1	2.9	8.5	4.9

DRIVE AXLES

Four wheel drive with inboard mounted planetary gears on all axles.

Oscillating front axle, fixed rear axle.

DIFFERENTIALS

Front - full differential with hydraulic lock.
 Rear - solid axle with no differential action
 - full differential without hydraulic lock

HYDRAULIC SYSTEM

Type - Closed center, constant pressure system. Includes power steering, power brakes, differential lock, front blade, and remote functions.

STEERING

Full power steering controlled by steering wheel. Frame steered by two hydraulic cylinders. Turning clearance circle (with blade)

Skidders with Syncro-Range (Direct Drive)
 (16.9 x 30 tires) 35 ft. 6 in.
 Skidders with Power Shift and Short Frame (16.9 x 30 tires) 35 ft. 6 in.
 Skidders with Power Shift and Long Frame (18.4 x 34 tires) 38 ft. 8 in.
 Turning radius
 Skidders with Syncro-Range (16.9 x 30 tires) (Direct Drive) 16 ft. 8 in.
 Skidders with Power Shift and Short Frame (16.9 x 30 tires) 16 ft. 8 in.
 Skidders with Power Shift and Long Frame (18.4 x 34 tires) 19 ft. 2 in.

BRAKES

Syncro-Range - Hydraulically operated disk type (Direct-Drive) on output shaft with single pedal control. Mechanical brake for parking and winching.
 Power Shift - Axle-mounted single disk brakes, hydraulically operated with single pedal control. Mechanical brake for parking and winching.

TIRE OPTIONS

14.9 x 28 (early models) . . .	8 ply (short frame only)
16.9 x 30	8 ply
18.4 x 26	10 ply
18.4 x 34 (early models) . . .	10 ply (long frame only)
23.1 x 26 (early models) . . .	10 ply (long frame only)

CAPACITIES (U.S. Standard Measures)

Fuel Tank	24 gals.
(Power Shift with long frame) .	42 gals.
Cooling System (JD440)	3 gals.
Cooling System (JD440-A and JD440-B)	4 gals.
Engine Lubrication (including filter)	9 qts.
Transmission case (includes hydraulic system)	Syncro-Range 8 gals. Power Shift 9 gals.
Front Differential	9 gals.
Rear Differential	4-1/2 gals.
Oil Bath Air Cleaner (early units)	1-1/2 qts.
Winch Housing (with filter)	9 qts.

WINCH

Model	No. 3305
Drum speed (at 2200 rpm engine speed)	58-1/2 rpm
Drum diameter	6 in.
Drum capacities*	
(with 1/2-inch cable)	195 ft.
(with 5/8-inch cable)	125 ft.
(with 3/4-inch cable)	100 ft.
Cable speed (at 2200 rpm speed using 5/8-inch cable)	
(with bare drum)	100 fpm
(with full drum)	159 fpm
Cable pull (at 2200 rpm engine speed) (calculated)	
(with bare drum)	14,500 lbs (JD440) 17,300 lbs (JD440 Series-A and JD440-B)
(with full drum)	9,150 lbs (JD440) 10,800 lbs (JD440 Series-A and JD440-B)

* Calculated Capacities - allowance must be made for loose or uneven spooling.

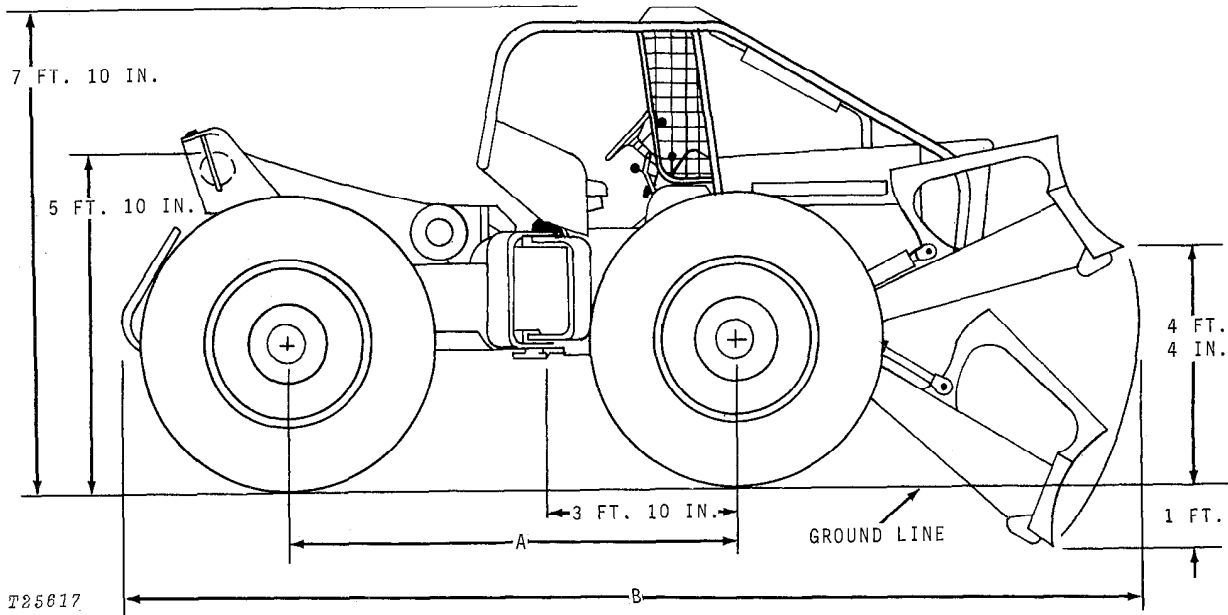

**Syncro-Range
 (Direct Drive)**

Power Shift

DIMENSIONS

(Skidder with 18.4-26 tires)

A. Wheel base	7 ft. 5 in.	8 ft. 8 in.
B. Over-all length (front blade extended, to log bumper)	17 ft. 4 in.	19 ft. 4 in.
Over-all height (to top of canopy)	7 ft. 10 in.	7 ft. 10 in.
Ground clearance	1 ft. 6 in.	1 ft. 6 in.
Over-all width	7 ft. 8 in.	7 ft. 10 in.
Stability weight	12,400	13,800

(Specifications and design subject to change without notice. Wherever applicable, specifications are in accordance with I.E.M.C. and S.A.E. standards.)

Group 10

PREDELIVERY, DELIVERY, AND AFTER-SALES SERVICES

PREDELIVERY SERVICE

Every new John Deere skidder leaves the factory so it can be delivered to the customer after a minimum of servicing.

Shipping factors, in addition to extra finishing touches needed for customer satisfaction, necessitate proper predelivery service on the part of the dealer.

A tag pointing out the factory-recommended procedure for predelivery service is attached to every new skidder before it leaves the factory.

After completing the factory-recommended checks and services listed on the predelivery tag, remove and file the tag with the job shop order. The tag and the customer's John Deere Delivery Receipt certify proper predelivery service when that section of his receipt is completed.

TEMPORARY MACHINE STORAGE

Service	Specifications	Reference
Check radiator for coolant loss and antifreeze protection.	Midway between radiator cover and filler neck.	FOS Manual 30— ENGINES
Fill fuel tank.	Operator's Manual
Check crankcase oil level.	Operator's Manual
Relieve hydraulic pressure.	Stop engine, lower skidder blade and operate cylinders to relieve pressure.
Cover exhaust inlet pipe.
Reduce shipping pressure of tires.	Operator's Manual
Check torque on wheel nuts.	Section 10, Group 25

PREDELIVERY INSPECTION

ELECTRICAL SYSTEM

Check battery terminals to be sure they are tight.	Operator's Manual
--	-------	-------------------

COOLING SYSTEM

Inspect radiator for coolant loss.	Midway between radiator core and filler neck.
Check antifreeze protection.	FOS Manual 30— ENGINES

PREDELIVERY INSPECTION—Continued

Service	Specifications	Reference
TIRES AND WHEELS		
Adjust pressure of tires.	Operator's Manual
Check torque on wheel nuts.	Section 10, Group 25
LUBRICATION		
Check crankcase oil level.	To upper marks on dipstick.	Operator's Manual
Check transmission-hydraulic system oil level.	Between marks on dipstick. Type 303 Special-Purpose Oil.	Operator's Manual
Check winch housing oil level.	Level with oil level hole.	Operator's Manual
Check rear differential housing oil level.	Level with oil level hole.	Operator's Manual
Lubricate grease fittings.	Operator's Manual
ENGINE		
Drain fuel tank sump and fuel filters.	Operator's Manual
Check air cleaner.	Operator's Manual
Fill fuel tank and start engine.	Operator's Manual
Check operation of lights, gauges, and indicator lamps.	Operator's Manual
Check speed control linkage for free operation.	Section 20, Group 20
Check engine idle speeds.	Section 20, Group 20
OPERATION		
Check engine clutch operation	Section 50, Group 10
Shift transmission through all speeds.	Operator's Manual
Check fire extinguisher.	Operator's Manual
Check winching brake.	Operator's Manual
Check steering, brakes, and hydraulic operations.	Operator's Manual
Check seat operation.	Operator's Manual

Predelivery Inspection—Continued

GENERAL

Remove fire extinguisher cold shut.
Tighten accessible nuts and cap screws.	Refer to torque chart. Section 10, Group 25
Clean skidder and touch up paint.

DELIVERY SERVICE

A thorough discussion of the operation and service of a new machine at the time of delivery helps to assure complete customer satisfaction. Proper delivery should be an important phase of a dealer's program. One section of the John Deere Delivery Receipt emphasizes the importance of proper delivery service.

Complaints may arise if the owner is not shown how to operate and service his new machine correctly. Devote enough time, at your customer's convenience, to introduce him to his new machine. Explain fully how to operate and service it.

The following procedure is recommended before the serviceman and owner complete the delivery acknowledgments section of the Delivery Receipt.

Using the operator's manual as a guide, make sure the owner thoroughly understands the following points:

1. Operation and use of controls and instruments.
2. Operation of the engine.
3. Importance of the break-in period.
4. Use of cast-iron ballast.
5. Operation and functions of the hydraulic system.
6. Importance of safety.
7. Importance of lubrication and periodic services.

After explaining and demonstrating the above points, have the owner sign the Delivery Receipt and give him his operator's manual.

AFTER-SALES INSPECTION

The purchaser of a new John Deere machine is entitled to a free inspection at some mutually agreeable time within the warranty period after the equipment has been "run in." The terms of this after-sales inspection are outlined on the customer's John Deere Delivery Receipt.

The purpose of this inspection is to insure that the customer is receiving satisfactory performance from his machine. At the same time, the inspection should reveal whether or not the machine is being operated, lubricated, and serviced properly.

If recommended after-sales service inspection is followed, the dealer can eliminate minor irregularities which can develop into major service problems at a later date. This will promote strong dealer-customer relations and give the dealer an opportunity to answer questions that may have arisen during the initial operation.

During the inspection service, the dealer has the opportunity to promote the sale of additional new equipment and accessories.

AFTER-SALES INSPECTION

Service	Specifications	Reference
Check radiator coolant level.	Midway between radiator cover and filler neck.	Operator's Manual
Clean external surface of radiator core.
Check hoses and connections for leaks.
FUEL SYSTEM		
Drain fuel tank sump and clean strainer.	Operator's Manual
Remove water and foreign matter from transfer pump (AC only) and filter sediment bowls.	Operator's Manual
Bleed fuel system.	Operator's Manual
Tighten loose connections and check entire system for leaks. Correct if necessary.
Check air cleaner element and clean, if necessary.	Operator's Manual
ELECTRICAL SYSTEM		
Check specific gravity and electrolyte level of batteries.	Full charge - 1.260 at 80°F.	FOS Manual 20 - ELECTRICAL SYSTEMS
Check belt tension.	3/4-inch belt deflection with 20 lb. force.	Operator's Manual
Start engine and check action of starter, lights, and indicator lamps.	Operator's Manual
LUBRICATION		
Check engine crankcase oil level.	To upper marks on dipstick.	Operator's Manual
Check transmission-hydraulic system oil level.	Between marks on dipstick. Use John Deere Type 303-Special-Purpose Oil.
Check differential housing oil level.	Level with oil level hole.	Operator's Manual
Check winch housing oil level.	Level with oil level hole.	Operator's Manual

AFTER-SALES INSPECTION—Continued

Service	Specifications	Reference
ENGINE		
Check valve clearance.	Section 10, Group 15
Check engine speed under load, fuel consumption, and horsepower.	FOS Manual 30 - ENGINES
GENERAL		
Check clutch pedal free travel (Syncro-Range).	Operator's Manual
Check winching brake free travel.	Operator's Manual
Check transmission linkage adjust- ment.	Section 50
Check power steering, brakes, and other hydraulic functions.	Section 70
Check winch operation.	Section 80, Group 5
Tighten accessible nuts and cap screws.	Refer to "Torque Chart"	Section 10, Group 25
Check fire extinguisher operation	Operator's Manual

Group 15

TUNE-UP AND ADJUSTMENT

GENERAL INFORMATION

Before tuning up an engine, determine if it is in condition so that performance can be restored by tune-up. Perform the following tests.

PRELIMINARY ENGINE TESTING

Operation	Specification	Reference
Vacuum test at air cleaner		
JD440 (Diesel)	14 to 25 inches of water at fast idle
JD440 Series-A, JD440-B (Diesel)	11 to 25 inches of water at fast idle
Manifold vacuum test (Gasoline)	15 to 20 inches of mercury at fast idle
Intake manifold pressure (engines with altitude compensating turbochargers)	6.38 to 9.32 psi at 2500 rpm (full load)	Section 30, Group 15
Check radiator for air bubbles and indication of oil.	Section 20, Group 25
Cylinder compression*		
JD440 Gasoline	120 psi	Section 20, Group 10
JD440 Diesel	300 psi	Section 20, Group 10
JD440 Series-A, JD440-B	350 psi	Section 20, Group 10

* The most important factor in compression readings is the difference between cylinders. This difference should be no more than 30 psi on gasoline engines or 50 psi on diesel engines.

ENGINE TUNE-UP

AIR INTAKE SYSTEM

Air cleaner (Dry Type) - clean filter element and dust cup.	Section 30, Group 15
Air cleaner (Oil Bath Type) - clean oil cup	Section 30, Group 15
Check breather pipe for restrictions
Tighten cylinder head cap screws	110 ft-lbs	Section 20, Group 10
Check valve clearance	Gasoline - 0.022 in. - Exhaust 0.014 in. - Intake Diesel - 0.018 in. - Exhaust 0.014 in. - Intake	Section 20, Group 10
Check for tight hose connections	Operator's Manual

IGNITION SYSTEM

Clean, adjust, test, or replace spark plugs.	0.025 in.	Section 40, Group 15
Check distributor cap, rotor, and wiring.	Section 40, Group 15
Clean, adjust, or replace points	0.020 in. gap 66° to 72° dwell	Section 40, Group 15
Lubricate distributor cam	Cam lubricant
Time distributor	"S" mark on front pulley at 2500 rpm	Section 40, Group 15

ENGINE TUNE-UP—Continued

Operation	Specification	Reference
BATTERY		
Check electrolyte level	Operator's Manual
Clean cables, terminals and box	Operator's Manual
Tighten cable clamps
ALTERNATOR		
Check belt tension	20 pounds at 3/4 in. deflection	Section 40, Group 10
GASOLINE FUEL SYSTEM (early models)		
Check fuel tank and lines for leaks or restrictions
Clean fuel transfer pump bowl and strainer	Section 30, Group 10
Check carburetor choke disk operation	Section 30, Group 20
Clean carburetor fuel inlet screen	Section 30, Group 20
Adjust speed control linkage and carburetor	Section 20, Group 20
DIESEL FUEL SYSTEM		
Check fuel tank and lines for leaks or restrictions
Clean fuel transfer pump and strainer (early units)
Replace first stage fuel filter element	Operator's Manual
Time injection pump	Section 30, Group 25
Check injection pump advance	Section 30, Group 25
Bleed fuel system	Operator's Manual
Adjust speed control linkage and check engine speeds	Section 20, Group 20
Check in line filter for obstructions (late models)	Operator's Manual
Back flush fuel tank strainer (late models)	Operator's Manual
Drain fuel tank sump	Operator's Manual
ENGINE LUBRICATION SYSTEM		
Check engine oil pressure		
(-21883)	30 to 40 psi at 2500 rpm (180° to 220°F.)	Section 20, Group 15
(21884-Up)	45 to 65 psi at 2500 rpm (180° to 220°F.)	Section 20, Group 15
COOLING SYSTEM		
Clean and flush system
Inspect hoses
Clean trash from radiator

FINAL ENGINE TESTING

Use a dynamometer in final testing to determine if engine is performing at rated horsepower. See "Specifications."

Compare output of engine with horsepower delivered prior to tune-up.

Use a dynamometer and exhaust gas analyzer for accurate and efficient carburetor adjustment.

SKIDDER ADJUSTMENT

Operation	Specification	Reference
ENGINE CLUTCH		
Check pedal free travel (Direct-Drive)	Section 50, Group 10
Lubricate clutch throw-out bearing (Direct Drive)	Operator's Manual
BRAKES		
Bleed brakes	Section 70, Group 25
Check action of brake accumulator	Section 70, Group 15
Check mechanical winching brake	Section 70, Group 25
POWER STEERING		
Bleed steering system	Section 70, Group 20
Adjust steering stop pins	Operator's Manual
Check time cycle (lock to lock)	3.0 seconds at 1000 rpm	Section 70, Group 5
SELECTIVE CONTROL VALVE		
Fully extend blade cylinder	2.5 to 3.0 seconds at 2500 rpm
Fully extend remote cylinder	2.0 to 2.5 seconds at 2500 rpm
POWER WINCH		
Check control lever adjustment	Section 80, Group 5
Check brake adjustment	Section 80, Group 5
TIGHTEN ACCESSIBLE BOLTS AND CAP SCREWS		
	See torque chart.	Section 10, Group 25

Group 20 LUBRICATION

GENERAL INFORMATION

Carefully written and illustrated instructions have been included in the operator's manual or Periodic Service Chart (late models) furnished with your customer's machine. Remind him to follow the recommendations in these instructions.

For your convenience, the following chart shows capacities and types of lubricants for the machine's various components and systems. Definitions of the lubricants follow the chart.

Component	Capacity	Type of Lubricant
Engine crankcase	9 U.S. quarts (8.5 l) (including filter)	See page 20-2.
Transmission case (includes hydraulic system and filters)	9 U.S. gallons (34 l) (Power Shift)	John Deere Hy-GARD Transmission and Hydraulic Oil or an equivalent
	8 U.S. gallons (30 l) (Direct Drive)	John Deere Hy-GARD Transmission and Hydraulic Oil or an equivalent
Differentials	4-1/2 U.S. gallons (17 l) without lock 9 U.S. gallons (34 l) with lock	John Deere Hy-GARD Transmission and Hydraulic Oil or an equivalent
Grease fittings	John Deere Multi-Pur- pose Lubricant or an equivalent
Axle bearings*	Until fresh grease escapes around seal	John Deere Multi-Pur- pose Lubricant or an equivalent
Starter (Diesel)	Saturate wicks	Engine crankcase oil (SAE 10W)
	Lubricate armature splines during assembly	Engine crankcase oil (SAE 10W)
Cooling system	4 gallons (15 l)	Summer coolant or anti- freeze

** Perform this service daily when operating in deep mud or water. NOTE: Lubricating not recommended in temperatures below 0°F (-18°C) as axle outer seals may be forced out of position. If seals are unseated, tap back to original position. Never use a power grease gun.*

LUBRICANTS

Effective use of lubricating oils and greases is perhaps the most important step towards low upkeep cost, long skidder life, and satisfactory service. Use only lubricants specified in this section; apply them at intervals and according to the instructions in the lubrications and periodic service section.

ENGINE LUBRICATING OILS



We recommend John Deere Torq-Gard or Torq-Gard Supreme engine oil for use in the engine crankcase. This oil is compounded specifically for use in John Deere engines, and provides superior lubrication under all conditions. NEVER PUT ADDITIVES IN THE CRANKCASE. Torq-Gard oil is formulated to provide all the protection your engine needs. Additives could reduce this protection rather than help it.

If oil other than Torq-Gard or Torq-Gard Supreme is used, it must conform to the following specifications.

SINGLE VISCOSITY OILS

API Service CD/SD
MIL-L-2104C
Series 3

MULTI VISCOSITY OILS

API Service CC/SD
MIL-L-46152.

Depending on the expected prevailing average daytime temperature for the fill period, use oil of viscosity as shown in the following chart.

Air Temperature	John Deere Torq-Gard Oil	Other Oils	
		Single Viscosity Oil	Multi-Viscosity Oil
Above 32°F (0°C)	SAE 30	SAE 30	Not recommended
-10°F to 32°F (-23°C to 0°C)*	SAE 10W-20	SAE 10W	SAE 10W-30
Below -10°F (-23°C)	SAE 5W-20	SAE 5W	SAE 5W-20

* SAE 5W-20 oil may also be used to insure optimum lubrication at starting, particularly when engine is subjected to -10°F. or lower temperatures for several hours.

Some increase in oil consumption may be expected when SAE 5W-20 or SAE 5W oils are used. Check oil level more frequently.

TRANSMISSION HYDRAULIC OIL

Use only John Deere Hy-GARD Transmission and Hydraulic Oil or an equivalent in the transmission-hydraulic system. Other types of oil will not give satisfactory service, and may result in eventual damage. This special oil, available from your John Deere dealer, may be used in all weather conditions.

GREASES

Use John Deere Multi-Purpose Lubricant or an equivalent SAE Multi-Purpose type grease for all grease fittings. John Deere Multi-Purpose Lubricant or an equivalent wheel bearing grease is recommended for rear axle bearings and for front wheel bearings. Application of grease as instructed in the lubrication section will provide proper lubrication and will keep contamination out of bearings.

STORING LUBRICANTS

Your skidder can operate at top efficiency only if clean lubricants are used. Use clean containers to handle all lubricants. Store them in an area protected from dust, moisture, and other contamination.

Group 25 SEPARATION

SEPARATING ENGINE AND EQUIPMENT FRAMES

Remove rubber hinge shields (if used) and batteries.

Disconnect winch control cable from winch valve and cable clamp. Remove seat with mounting bracket.

Support front and rear sections of equipment frame and engine frame as evenly as possible to prevent frames from pivoting.

Upper Pivot

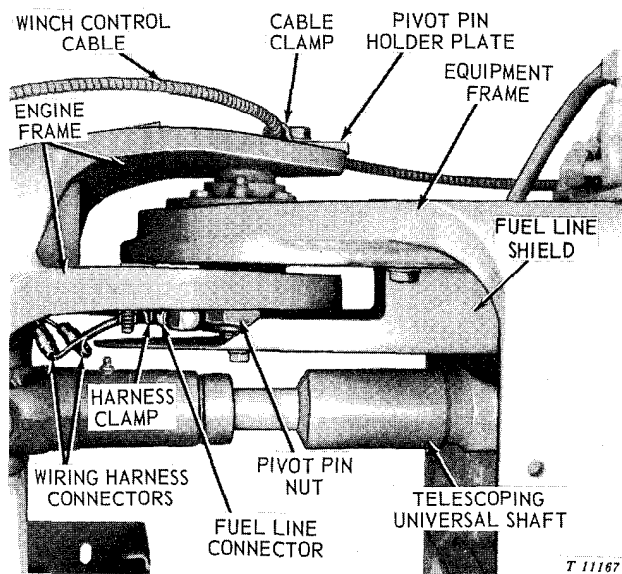

Fig. 1-Upper Pivot

Disconnect fuel tank sending unit lead and rear wiring harness lead connectors.

Disconnect all lines between equipment and engine frames. Be sure to note correct position of lines for assembly.

Disconnect winch drive shaft.

Remove nut and drive upper pivot pin through pivot.

Lower Pivot

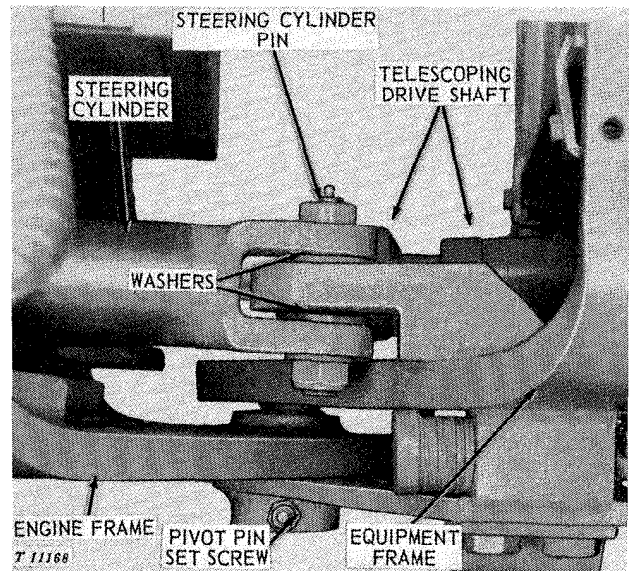

Fig. 2-Lower Pivot (Units -18036)

Disconnect steering cylinders from equipment frame.

Disconnect lower telescoping drive shaft.

Remove retaining screw and drive lower pivot pin through pivot points.

Separate equipment frame from engine frame.

JOINING ENGINE AND EQUIPMENT FRAMES

1. Align upper and lower pivot points, install pins and tighten to specified torque.

2. Connect drive lines.

3. Secure steering cylinders to equipment frame and tighten nuts to specified torque.

4. Connect all lines between equipment and engine frames. Connect wiring harness. Install seat. Connect winch control cable and install cable clamp the specified distance between pivot pin and clamping groove.

5. Connect batteries and install rubber hinge guards (if used).

REMOVING ENGINE

Disconnect battery cables and remove muffler and hood.

Remove grille screen and disconnect oil cooler and upper radiator support from grille housing. Disconnect air cleaner hose.

Disconnect grille housing and remove housing from engine frame. Remove front bottom guard.

Detach the wiring and linkage on both sides of the engine necessary for engine removal.

Disconnect main pump inlet and pressure lines.

Disconnect oil cooler lines at top of cooler.

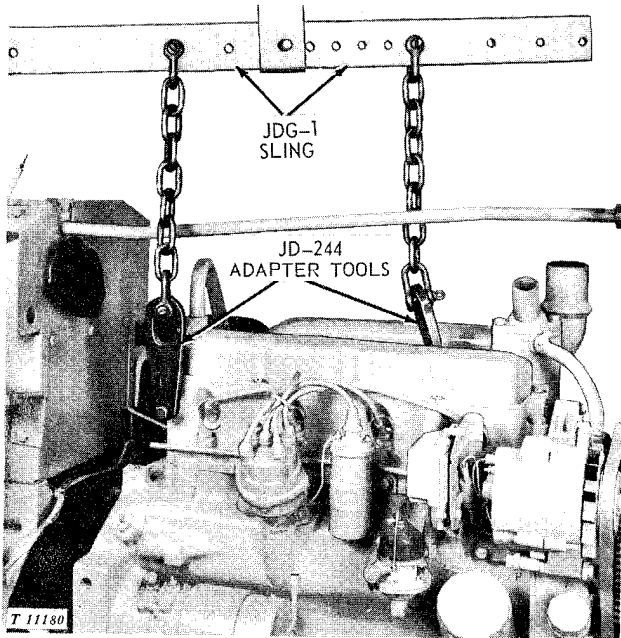

Fig. 3-Removing Engine (Gasoline Shown)

Attach JDG-1 or JDG-23 Engine Lifting Sling or D01043AA Load Positioning Sling to engine using two JD244 Lifting Eyes or JDG-19 Lifting Brackets.

Place blocking between engine frame and clutch housing at the front differential so that the clutch housing does not settle while engine is being removed.

Remove cap screws securing engine to frame and clutch housing. Remove engine from unit (Fig. 3).

If complete engine service is necessary, remove main pump, radiator, and front end support from engine.

INSTALLATION

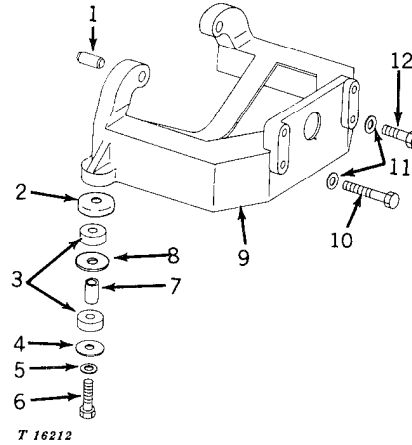

- | | |
|--------------------------|-----------------------|
| 1—Dowel Pin (2 used) | 7—Spacer (2 used) |
| 2—Cup (2 used) | 8—Washer (2 used) |
| 3—Rubber Washer (4 used) | 9—Support |
| 4—Washer (2 used) | 10—Cap Screw (2 used) |
| 5—Lock Washer (2 used) | 11—Washer (4 used) |
| 6—Cap Screw (2 used) | 12—Cap Screw (2 used) |

Fig. 4-Engine Front Support

Attach front end support, radiator, and main pump to engine.

Using hoist install engine in unit. Bar engine over to index transmission drive shaft with clutch disk.

Secure engine to clutch housing and engine frame with attaching cap screws and tighten cap screws to the specified torque. Be sure rubber pads are on front mounts.

Coat tachometer cable gasket with Lubriplate and install on cable. Index slot in cable to coupler and tighten so that no oil leaks from around cable. Do not tighten too tight or gasket will be damaged and oil leaks will form.

Install grille housing and secure cooler and radiator to housing. Connect air cleaner.

Install hood, muffler, and grille screen. Connect battery cables.

REMOVING CLUTCH HOUSING AND COWL (Syncro-Range)

All components in the clutch housing and cowl may be serviced within the skidder by removing the engine and transmission as required. If the clutch housing is to be replaced, remove cowl, clutch housing, and transmission in one unit, as follows:

1. Disconnect battery cables.
2. Remove hood, operator side shields, cowl covers, footrest, seat with mounting bracket and transmission top shield. For added hoisting clearance, remove canopy.
3. Remove engine with front support, main pump, and radiator as a unit. See "Engine Removal."
4. Disconnect hydraulic lines from front differential and steering cylinders.
5. Disconnect fuel line(s) and wiring harness between equipment and engine frames.
6. Attach hoist with lift brackets to transmission case and clutch housing as shown in Figure 5.
7. Disconnect transmission front and rear drive lines. Disconnect winch drive line.
8. Remove transmission mounting brackets and using a hoist remove transmission and clutch housing assemblies out of unit.

Disassemble assemblies on bench by referring to the proper section and group.

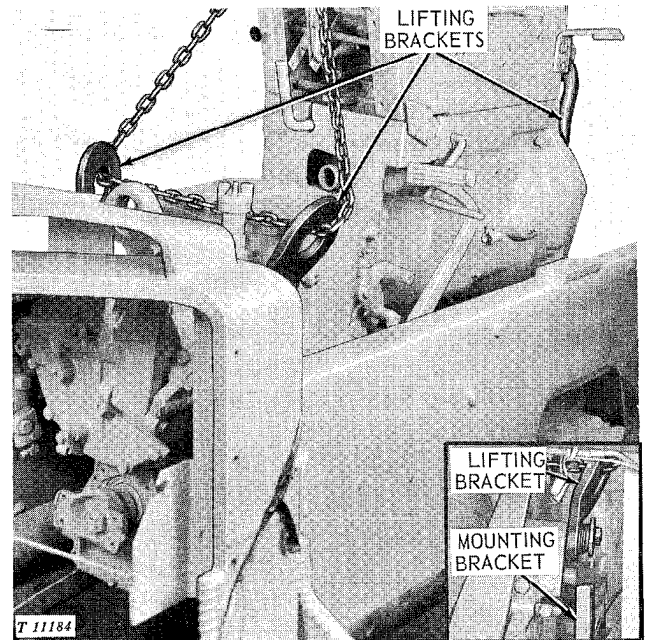

Fig. 5-Removing Clutch Housing and Transmission

INSTALLATION

1. Connect clutch housing to transmission and hoist assemblies in engine frame. Install all hydraulic lines in the reverse order of removal.
2. Install transmission mounting brackets. Do not tighten attaching cap screws until after engine is installed. As an aid in engine installation, the top cap screws on each side can be removed to permit the front of the clutch housing to pivot up.
3. Connect transmission drive and winch drive lines. Connect fuel lines and rear wiring harness.
4. Install engine as instructed in this Group.
5. Install canopy and all sheet metal. Install batteries and connect cables.

REMOVING UPPER COWL (Power Shift)

All components in the upper cowl may be serviced separately. The upper cowl is removed as follows to facilitate clutch housing and transmission servicing without removing them from the skidder.

Disconnect battery cables.

Remove hood, operator side shields, cowl covers, footrest, and transmission top shield.

Disconnecting Right Side of Cowl

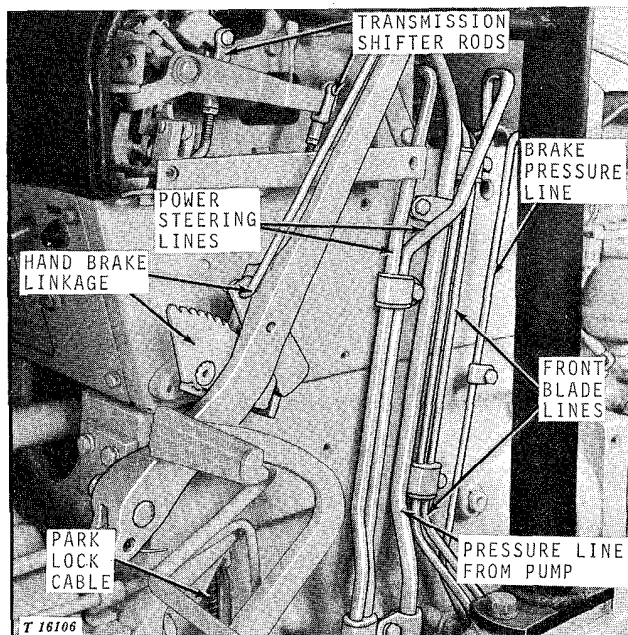

Fig. 6—Disconnecting Right Side of Cowl

Disconnect foot throttle and hand brake linkage from cowl.

Disconnect main pump pressure line, steering cylinder lines, brake pressure line and front blade lines at both ends and remove lines from unit.

Disconnect oil cooler top lines, engine oil pressure tube, temperature sending unit, and diesel cold weather starting aid.

Disconnect transmission shifter rods, park lock cable, and starter safety switch lead.

Disconnecting Left Side of Cowl

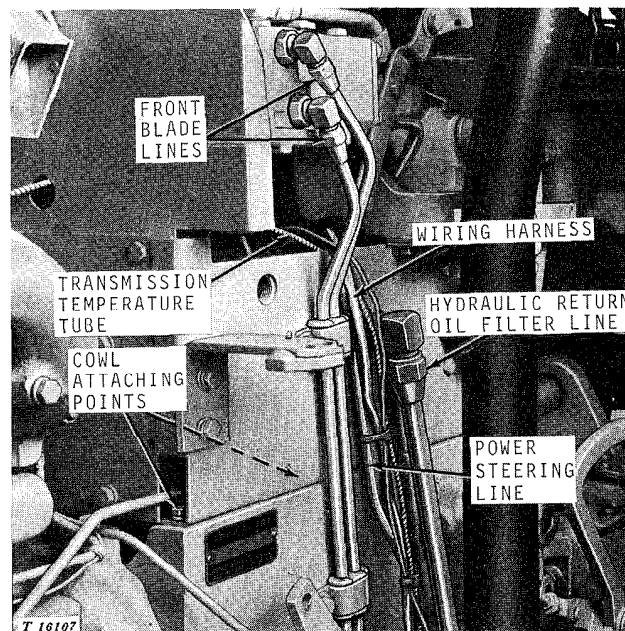

Fig. 7—Disconnecting Left Side of Cowl

Disconnect transmission temperature cable.

Remove front blade lines, power steering line, and filter relief valve line.

Disconnect wiring harnesses from cowl.

Remove cap screws securing upper cowl to clutch housing and remove cowl from unit.

INSTALLATION

Install upper cowl on clutch housing and secure with attaching cap screws.

Install all lines removed from both sides of unit as shown in Figures 6 and 7.

Connect wiring harness and linkage on both sides of unit.

Install all sheet metal and connect battery ground straps.

REMOVING SYNCRO-RANGE TRANSMISSION

1. Disconnect battery cables. Remove seat with mounting bracket, operator side shields, footrests, transmission top shield, and engine frame rear bottom guard.
2. Remove cap screws from canopy center and rear attaching points. Loosen front cap screws and block canopy upward until rear canopy bar is up over engine frame.
3. Remove winch drive shaft and disconnect the following: winching brake, clutch pedal rod, brake bleed line, starter safety switch lead, transmission shifter rods, main pump inlet line, hydraulic functions return line, and the differential return line.
4. Remove differential lock valve and brake piston housing. Disconnect transmission front and rear drive lines.
5. Using a puller remove steering wheel. Remove transmission top cover.
6. Place blocking between engine frame and clutch housing at front differential so that center frame does not settle during transmission removal and installation.
7. Remove cap screws securing transmission to clutch housing (two cap screws are inside top of transmission) and rear mounting brackets. Remove rear mounting brackets for added clearance.
8. With transmission completely disconnected, pull transmission rearward off clutch housing until case clears transmission drive shaft in clutch housing. Then lift transmission straight up between sides of engine frame.

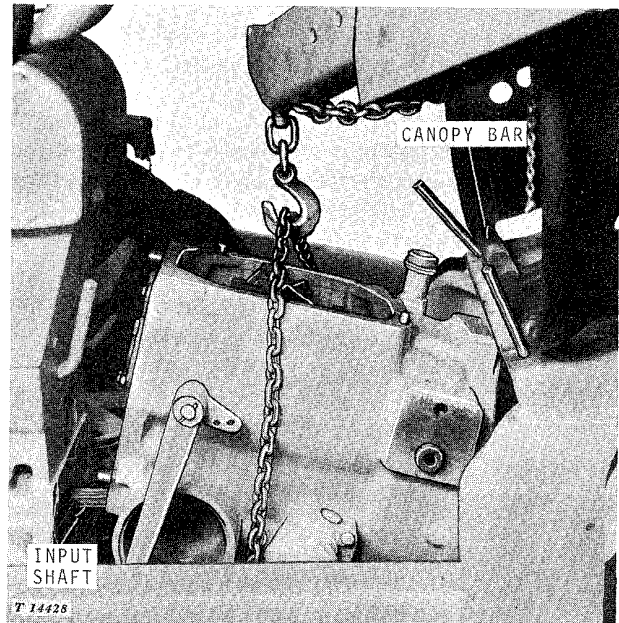

Fig. 8-Removing Transmission

INSTALLATION

Position transmission case in engine frame. Install all attaching cap screws and tighten to specified torque.

Tighten attaching cap screws around clutch housing using a straight 1-1/8-inch box end and 3/4-inch drive adapter wrench, 5 inches long. Position wrench on cap screws and attach extensions toward rear of transmission so that torque wrench fits between engine and equipment frame.

Remove blocking between engine frame and clutch housing.

Install brake piston housing and differential lock valve. Install all lines and linkage in reverse order of removal.

Secure canopy and seat with bracket. Install all sheet metal.

Fill transmission with recommended oil (Group 20).

Install batteries and connect cables.

REMOVING POWER SHIFT TRANSMISSION

The transmission and clutch housing may be completely serviced within the skidder by removing the engine and upper cowl. If either of the assemblies are to be completely changed, remove the upper cowl, clutch housing, and transmission as a unit.

1. Remove engine with front support, main pump, and radiator as a unit. See "Engine Removal."

2. Disconnect oil lines and linkage as instructed in "Upper Cowl Removal." (Cowl may be removed with transmission and clutch housing.)

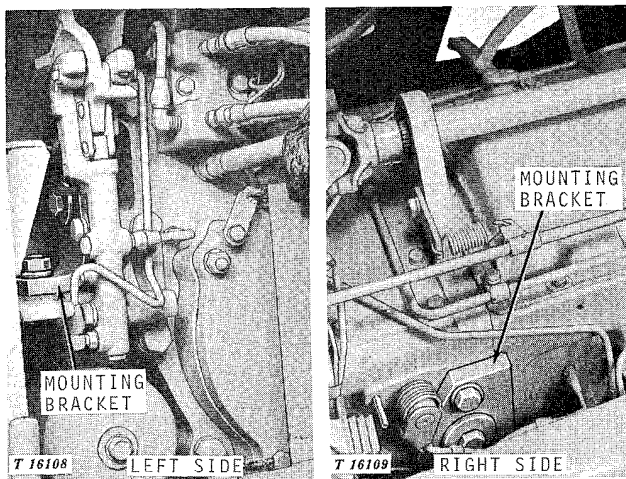

Fig. 9-Transmission Attaching Points

3. Remove seat with mounting bracket. For added hoisting clearance, remove canopy from unit.

4. Attach hoist to transmission and clutch housing.

5. Disconnect differential lock valve lines and remove valve from unit. Disconnect oil lines from front junction block.

6. Disconnect transmission front and rear drive lines. Disconnect winch drive line.

7. Remove transfer case rear mounting brackets (Fig. 9) and lift transmission-clutch housing assembly up so that brake valve can be removed.

8. Using a hoist, remove transmission and clutch housing as an assembly.

Disassemble and service assemblies on bench by referring to the specific Section and Group covering the components.

INSTALLATION

Connect clutch housing to transmission and hoist assemblies in engine frame. Install all hydraulic lines in the order that they were removed.

Install brake valve assembly.

Tighten transfer case to rear mounting bracket cap screws to specified torque (Fig. 9).

Connect transmission drive and winch drive lines. Connect oil lines to front junction block.

Connect lines and linkage as instructed in "Installing Upper Cowl."

Install all sheet metal. Install batteries and connect cables.

REMOVING AXLE HOUSING AND DIFFERENTIALS

Rear Differential And Axle Housing Removal

Disconnect battery ground strap, remove bottom guard, and support front and rear of equipment frame.

Drain oil from differential.

Attach a chain around each axle housing to support axles and differential assembly. Remove wheels from both axles.

Disconnect differential lock pressure and return lines at differential housing (if equipped with lock). Disconnect brake line.

Disconnect differential drive line.

Remove cap screws and clamps securing axle housings to equipment frame. Lower assembly from equipment frame.

Separate axle housings from differential housing as required.

An alternate method of removing rear differential is to disconnect axle housings from equipment frame, lift equipment frame, and roll assembly out from under frame.

Rear Differential And Axle Housing Installation

Lift differential with axle housings in position under equipment frame.

Install equipment frame clamps around axle housing and insert top clamp cap screws from the rear and bottom clamp cap screws from the front. Tighten to the specified torque.

Connect differential lock and brake lines.

Install equipment frame bottom guard.

Fill rear differential with recommended oil to the proper level (Group 20).

Front Axle Housing Removal

Disconnect battery ground strap and support front and rear of engine frame.

Drain oil from front differential.

Remove wheel from the axle housing to be removed.

Pivot or block up opposite axle to provide clearance under frame. Remove cap screws and pull axle housing from differential.

Front Axle Housing Installation

Position axle drive shaft and brake facing plate in differential assembly. With axle housing positioned against final drive shaft, turn axle shaft slowly to align planet pinions with sun pinion.

Draw up two attaching cap screws finger tight and turn axle shaft to be sure that the brake disk is splined correctly and axle shaft is free to turn.

Tighten axle housing attaching cap screws to the specified torque. Install wheel and tighten cap screws to the specified torque.

Refill differential housing (see Group 10).

Front Differential Removal

Disconnect battery ground strap; remove engine frame bottom guards and support front and rear of engine frame. Drain oil from differential.

Attach a chain around each axle housing to support axles and differential assembly. Remove wheels from both axles.

Disconnect differential lock pressure and return lines at differential housing. Disconnect brake line. Disconnect differential drive line.

Remove pin from front differential oscillating support bracket. Remove cap screws from rear support bracket and lower assembly from engine frame.

Front Differential Installation

Lift differential with axle housings into position under engine frame.

Place as many shims as needed between thrust plates and front support (Fig. 10). Install pin through front support into differential housing.

Secure rear support brackets to engine frame with dowels, cap screws, plain washers, and hex. nuts.

The large flat washers fit on top of engine frame over the two rear cap screws of each support to cover dowels.

Adjusting End Play on Axle Oscillating Front Pivot

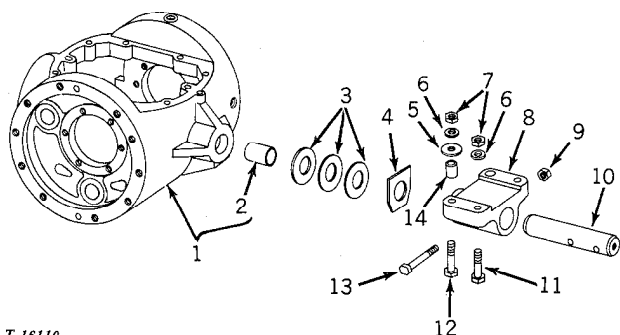

T 16110

- | | |
|---------------------|--------------------------|
| 1—Differential Case | 8—Support |
| 2—Bushing | 9—Lock Nut |
| 3—Washer (3 used) | 10—Pin |
| 4—Thrust Plate | 11—Cap Screw (2 used) |
| 5—Washer (3 used) | 12—Cap Screw (2 used) |
| 6—Washer (4 used) | 13—Cap Screw |
| 7—Hex. Nut (4 used) | 14—Hollow Dowel (2 used) |

Fig. 10-Front Axle Oscillating Pivot

Pivot and pry front differential assembly rearward as far as possible. With front oscillating support bracket thrust plate mounted next to differential and its straight edge up, measure the distance between thrust plate and support bracket with a feeler gauge (Fig. 10). Refer to "Specifications" for correct end play.

To adjust, do the following: (1) Support differential assembly with floor jack and remove cap screw securing front pin to support bracket. (2) Pull pin out halfway and add or deduct washers between thrust plate and support bracket to provide specified end play on front oscillating support bracket. (3) Push front pin back into differential case and install cap screw with hex. nut and grease fitting.

After adjusting front axle end play, check rotation of front axle. Check force required to oscillate axle assembly at hub end (without tires and rims). If force required to rotate axle is more than specified, readjust oscillating pivot end play.

Final Assembly

Connect differential drive lines and install wheels.

Connect differential lock pressure line and brake line.

Install engine frame bottom plates.

Fill differential with recommended oil (Group 20).



SPECIFICATIONS

Differential oscillating pivot end play 0.001 to 0.036 inch
 Maximum force required to rotate front axle freely 50 pounds
 Length of winch control cable between pivot pin and clamping groove 20 inches

TORQUE VALUES

Upper pivot pin nut	300 ft-lbs
Steering cylinder pin nut	150 ft-lbs
Engine-to-engine front support	170 ft-lbs
Engine front support-to-engine frame	170 ft-lbs
Engine-to-clutch housing	170 ft-lbs
Axle housing-to-differential housing ...	130 ft-lbs
Drive shaft universal joint-to-yokes ...	70 ft-lbs
Oscillating supports-to-engine frame (Synco-Range)	170 ft-lbs
(Power Shift)	445 ft-lbs
Oscillating front support pin screw	130 ft-lbs
Equipment frame-to-axle housing clamp screws	200 ft-lbs
Cast wheel-to-rim stud nuts (early model)	275 ft-lbs
Wheel retainer cap screw Early Units	170 ft-lbs
Later Units	240 ft-lbs
Rim-to-axle stud nut (JD440-B)	380 ft-lbs
Front blade pivot-to-engine frame	170 ft-lbs
Steering wheel shaft nut	50 ft-lbs
Canopy-to-engine frame screws	300 ft-lbs
<i>Synco-Range (Direct Drive)</i>	
Transmission mounting brackets-to- transmission case	170 ft-lbs
Transmission mounting brackets-to- engine frame	300 ft-lbs
Inside top of transmission case to clutch housing	170 ft-lbs
Clutch housing-to-transmission case ...	300 ft-lbs
<i>Power Shift</i>	
Transmission case to transfer case ...	300 ft-lbs
Transmission mounting bracket-to- transfer case	170 ft-lbs
Transmission mounting bracket-to- engine frame	300 ft-lbs
Transmission case to clutch housing 5/8-inch cap screws	170 ft-lbs
3/4-inch cap screws	300 ft-lbs
All hydraulic pump and cooler hose clamps	25 in-lbs

TORQUE CHART

RECOMMENDED TORQUE IN FT.-LBS COARSE AND FINE THREADS			
	B	D	F
			
Bolt Diameter	Plain Head	Three Dashes	Six Dashes
1/4	Not used	10	14
5/16	Not used	20	30
3/8	Not used	35	50
7/16	35	55	80
1/2	55	85	120
9/16	75	130	175
5/8	105	170	240
3/4	185	300	425
7/8	160	445	685
1	250	670	1030
1-1/8	330	910	1460
1-1/4	480	1250	2060

The types of bolts and cap screws are identified by head markings as follows:

Plain Head: regular machine bolts and cap screws.

3-Dash Head: tempered steel high-strength bolts and cap screws.

6-Dash Head: tempered steel extra high-strength bolts and cap screws.

Machine bolts and cap screws 7/8 inch and larger are sometimes formed hot rather than cold, which accounts for the lower torque.

SPECIAL TOOLS

No.	Name	Use
CONVENIENCE TOOLS		
JD244	Engine Lift Eyes	To Remove Engine
JDG-19	Lifting Bracket	To Remove Engine
JDG-1 or JDG-23	Engine Lifting Sling	To Remove Engine
D01043AA	Load Positioning Sling	To Remove Engine

Section 20 ENGINE

CONTENTS OF THIS SECTION

	Page		Page
GROUP 5-Diagnosis		GROUP 20-GOVERNOR AND SPEED	
Diagnosing Engine Malfunctions	5-2	CONTROL LINKAGE	
		Diagnosing Malfunctions	20-1
GROUP 10-BASIC ENGINE		Governor	20-1
Diagnosing Basic Engine Malfunctions	10-1	Speed Control Linkage	20-4
Head Assembly	10-1	Speed Control Adjustments	20-4
Adjusting Valve Tappets	10-3		
Block, Liners, Pistons, and Rods	10-4	GROUP 25-ENGINE COOLING	
Crankshaft, Main Bearings, and		Diagnosing Malfunctions	25-1
Flywheel	10-10	Radiator	25-1
Camshaft	10-14	Water Pump	25-1
Balancer Shafts	10-16	Oil Cooler	25-3
Timing Gear Train	10-18		
		GROUP 30-SPECIFICATIONS AND SPECIAL	
GROUP 15-ENGINE LUBRICATION		TOOLS	
Oil Pump and Filter	15-1	Basic Engine	30-1
Tests and Diagnosis	15-2	Lubrication System	30-8
		Governor and Speed Control Linkage	30-9
		Engine Cooling	30-10

Group 5

DIAGNOSING MALFUNCTIONS

DIAGNOSING ENGINE MALFUNCTIONS

The following is a quick guide for diagnosing engine malfunctions. Each malfunction is elaborated further in the section or group in this manual pertaining specifically to the component or system.

Engine Hard to Start, Will not Start

- Check fuel system (Section 30).
- Check electrical system (Section 40).
- Check ignition (Section 40).
- Check air system (Section 30).
- Low compression (Group 10).

Engine Starts, Won't Continue to Run

- Check fuel system (Section 30).
- Check ignition (Section 40).
- Check air intake system (Section 30).

Engine Loses Power

- Too high viscosity oil in crankcase.
- Check fuel system (Section 30).
- Check ignition (Section 40).
- Check air intake system (Section 30).
- Low compression (Group 10).

Diesel Engine Emits Black or Gray Exhaust Smoke

- Check air intake system (Section 30).
- Check fuel system (Section 30).
- Low compression (Group 10).

Engine has Low Oil Pressure

- Check lubrication system (Group 15).

Engine Speed is Erratic

- Check fuel injection pump (Group 30).
- Check governor (Group 20).
- Check speed control linkage (Group 20).

Engine Makes Abnormal Noise

- Check timing (Section 40; Section 30).
- Improper fuel (Section 30).
- Worn or improperly adjusted engine parts (Group 10).
- Plugged injection nozzles (Section 30).

Engine Operates at Abnormal Temperature

- Check cooling system (Group 25).
- Check ignition timing (Section 40).
- Check fuel injection timing (Section 30).

Engine Consumes Excessive Fuel

- Check fuel system (Section 30).
- Check ignition (Section 40).
- Check air intake (Section 30).
- Low compression (Group 10).

Engine Misses

- Low compression (Group 10).
- Check fuel system (Section 30).
- Check ignition system (Section 40).

Group 10 BASIC ENGINE

DIAGNOSING BASIC ENGINE MALFUNCTIONS

Engine Noise (Valve Train)

- Improperly adjusted valve clearance
- Valve rotators inoperative (gasoline)
- Worn shaft or rocker arm bore
- Bent push rods
- Worn camshaft or cam followers

Engine Noise (Piston and Pins)

- Worn piston
- Worn piston pin or bushings
- Broken piston

Engine Noise (Bearings)

- Worn connecting rod bearings
- Excessive crankshaft end play
- Excessive main bearing clearance

Engine Noise (Timing Gear Train)

- Worn gears

Engine uses Excessive Amount of Oil

- Worn valve guides
- Valve deflectors worn or missing (gasoline)
- Stuck piston rings or worn rings
- Excessive connecting rod bearing clearance
- Excessive oil pressure
- Crankcase oil diluted with fuel
- Engine overloaded
- Clogged breather pipe

Low Compression

- Worn rings
- Burned valves
- Damaged Pistons
- Failed head gaskets

Engine Misses

- Improperly adjusted valves
- Burned valves
- Weak valve springs
- Low compression on one or more cylinders
(Also see Ignition, Section 40; Fuel System, Section 30)

Lack of Engine Power

- Low compression on some or all cylinders
- Improperly adjusted valves
- Burned valves (check compression)
- Valves sticking
(Also see Ignition, Section 40; Fuel System, Section 30)

Coolant in Crankcase

- Failure of head gasket
- Cracked head or block
- Leakage at cylinder liner seal

CYLINDER HEAD, VALVES, AND ROCKER ARMS

Removal

The engine need not be removed from unit to service cylinder head, valves, and related parts.

Plug all open injection lines. Remove injection nozzles from head. (Nozzle tips extend below face of cylinder head and may be accidentally damaged.)

Repair

Do not rotate crankshaft with cylinder head removed unless all cylinder liners are bolted down.

Inspecting Cylinder Head

Check valve stem to guide clearance. Valves are available with standard size or oversize stems.

Valve guides must be precision reamed to match oversized valves. Make sure valves fit freely in guides.

Worn valve guides should be reconditioned by knurling. Use knurling tool D-20002WI exactly as recommended by the manufacturer.

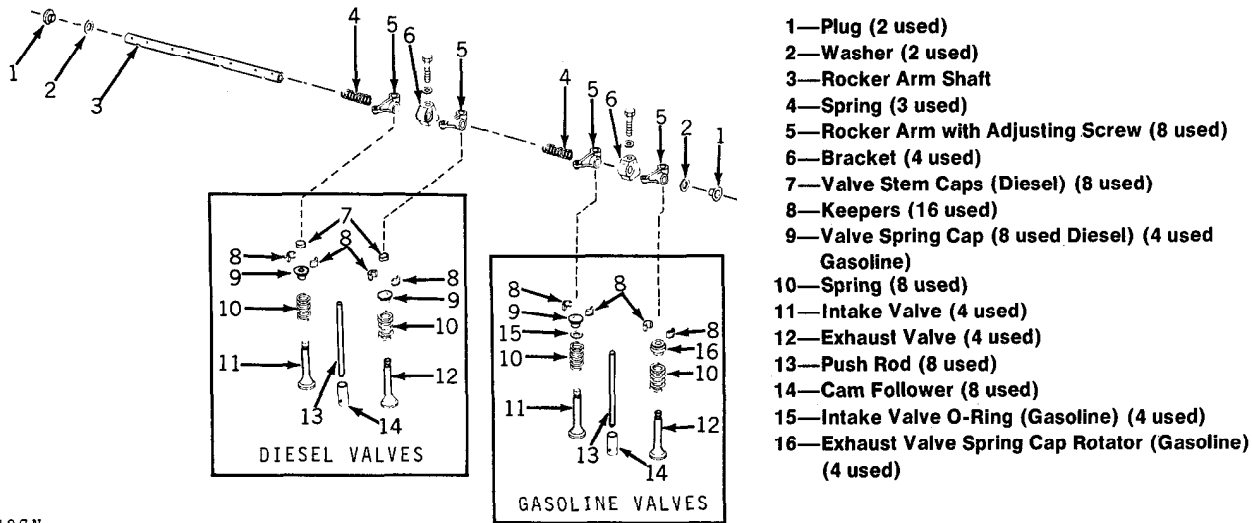

Fig. 1-Rocker Arm Assembly

T30727N

Check to determine if cylinder head is flat and smooth. If it is necessary to resurface the bottom deck of the head, remove no more material than absolutely necessary (not to exceed 0.030 inch).

On diesel engines check distance from the bottom deck of the cylinder head to the valves when seated. The distance for intake valves must be 0.037 ± 0.007 inch, the distance for exhaust valves must be 0.057 ± 0.007 inch.

Refacing Valves

If end of valve stem on gasoline engine is excessively pitted or worn by rocker arm, grind down end of valve until squared. On diesel engines, replace valve stem caps if worn or damaged.

Inspecting Valve Springs

Check compression strength of springs.

Inspecting Rocker Arm Assembly

Make sure that rocker arm oil holes are not plugged.

If ends of arms are worn, resurface them.

Thoroughly clean holes in rocker arm mounting brackets. This is especially important for the rear bracket, because oil is fed to the rocker arm shaft through this hole.

On gasoline engines, replace the intake valve stem O-ring.

If a failed valve has been replaced, it may be necessary to replace the rocker arm and push rod for that valve if they are damaged.

Valve Rotators (Gasoline)

On gasoline engines, inspect valve rotators. If rotator will not turn freely in one direction, replace with a new part.

Assembly

Rocker Arm Assembly

Assemble parts to rocker arm shaft in sequence that they were removed (Fig. 1).

Oil hole in rocker arm shaft to shaft support must face downward when assembly is installed on cylinder.

Apply AR44402 Valve Stem Lubricant to valve stems and install valves in valve guides, working them back and forth to make sure they slip through the ports easily and seat properly.

On gasoline engines, place oil deflectors (O-rings) on intake valve stems and place Rotocaps on exhaust valves.

Note also the following:

1. Use new valve keepers.
2. After assembly, "pop" each spring and valve assembly three or four times by tapping the end of each valve stem with a soft mallet.

INSTALLATION

Install cylinder head gasket dry.

On JD440-A and JD440-B, position cylinder head gasket over dowels on cylinder block. Check distance between cylinder head gasket and cylinder liner. Distance should be equal within 0.040 in. around each cylinder liner. If distance is not equal, make dowel holes in cylinder head gasket larger.

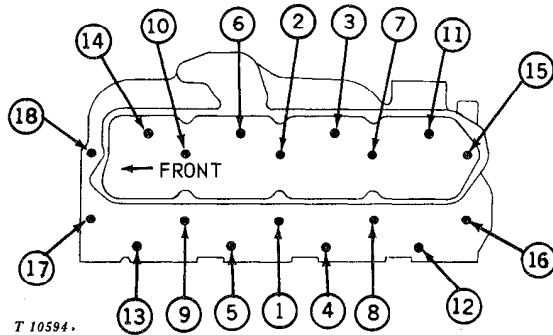

Fig. 2-Proper Sequence for Tightening
Cylinder Head Cap Screws

Use specified flat washers under all cap screws. Dip cap screws in oil prior to installation. Start cylinder head to cylinder block cap screws by hand and tighten evenly to 95 lb-ft, following sequence in Fig. 2.

Install push rods in location from which they were removed.

On diesel engines, position valve stem caps over ends of valve stems. Make certain the caps rotate freely on the stems.

Install rocker arm and shaft assembly on cylinder head. Tighten cap screws to 35 ft-lbs.

Adjusting Valve Tappet Clearance

The engine may be either hot or cold during valve adjustment.

Position No. 1 cylinder (located at fan end) on TDC of its compression stroke. Timing cover screw will enter its hole in flywheel (Fig. 3).

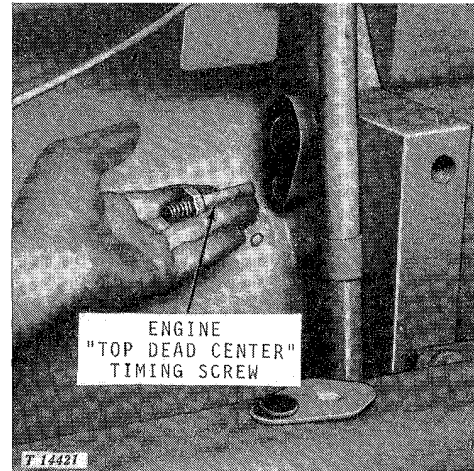

Fig. 3-Setting No. 1 Cylinder at Top Dead Center

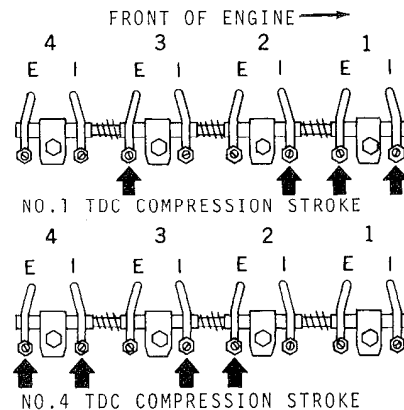

Fig. 4-Adjusting Valve Tappet Clearance

Adjust valve clearance on No. 1 and 3 exhaust valves to 0.018-inch for diesel and 0.022-inch for gasoline, and No. 1 and 2 intake valves to clearance of 0.014-inch for both gasoline and diesel. Using a feeler gauge to measure clearance, turn valve adjusting nut up or down until clearance is correct.

Remove timing screw from flywheel. Rotate engine flywheel 360 degrees and reinsert timing screw into hole on flywheel rim.

Adjust valve clearance on No. 2 and 4 exhaust and No. 3 and 4 intake valves to clearances specified.

Remove timing screw from flywheel and reinstall timing cover.

If piston rings or liners have been replaced, follow "Engine Break-In Procedure" page 20-30-5. If piston rings or liners have not been replaced, run the engine for 30 minutes at about 3/4 load after warm-up. Re-torque cylinder head cap screws and reset valve clearance.



Suggest:

If the above button click is invalid.

Please download this document

first, and then click the above link

to download the complete manual.

Thank you so much for reading

CYLINDER BLOCK, LINERS, PISTONS, AND RODS

General Information

CYLINDER BLOCK and crankcase are cast in one piece.

CYLINDER LINERS are of the replaceable wet-sleeve type, made of alloy cast iron and are a slip fit in the cylinder block. The flange of each liner rests on a shoulder within the block and is sealed by packings. (Later model engines have three packings at each cylinder.) The top edge of the liner is sealed with the cylinder block by the compression of the cylinder head and gasket.

PISTONS are aluminum-alloy, cam ground and weight-controlled, with two compression rings and one oil control ring. The crown of each diesel piston has a cut-out swirl cup.

CONNECTING RODS have a bronze bushing for the piston pin and a replaceable, steel-backed, aluminum-lined bearing insert.

Removal

Remove the pistons and connecting rods noting the following:

1. Engine normally need not be removed from unit to service pistons, connecting rods, and cylinder liners. If engine has to be removed, see Section 10, Group 25.

2. Do not rotate crankshaft with cylinder head removed unless all cylinder liners are bolted down. Bolt down cylinder liners before removing pistons.

3. Each connecting rod and piston must be reinstalled in the cylinder bore from which it was removed. Observe the word "FRONT" stamped on the head of all pistons and in the rib of the diesel connecting rods. These must face toward the fan end of the engine at the time of reassembly. Observe the "pip" marks on both the connecting rod and cap of a gasoline engine. These "pip" marks must both face towards the camshaft side of the engine at the time of reassembly.

4. The tangs for locating the bearing inserts are on the lower side of the connecting rod and cap. The cylinder location number is also located on the lower side. The lower side is installed toward the cam shaft side of the engine.

Repair

Inspect all parts and compare with "Specifications." Note especially the following.

Check ring grooves for excessive wear by placing ring groove wear gauge JDE62 in the Keystone ring grooves (Fig. 5). If the wear gauge shoulders contact the ring land, there is excessive wear.

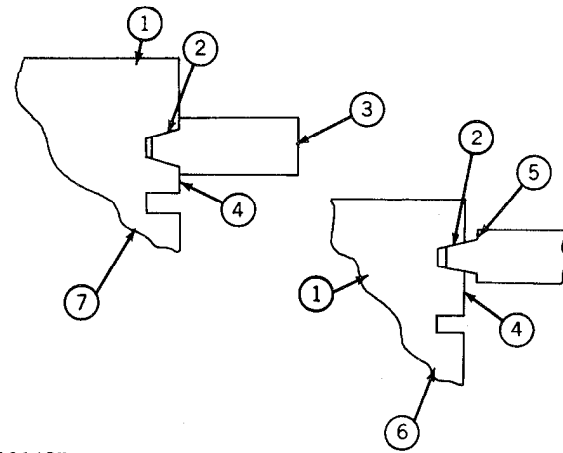

T28147N

- | | |
|------------------------|--------------------|
| 1—Piston | 5—Gauge Shoulder |
| 2—Keystone Ring Groove | 6—Good Ring Groove |
| 3—Wear Gauge | 7—Worn Ring Groove |
| 4—Ring Land | |

Fig. 5—Using Ring Groove Wear Gauge

<https://www.ebooklibonline.com>

Hello dear friend!

Thank you very much for reading.

Enter the link into your browser.

The full manual is available for immediate download.

<https://www.ebooklibonline.com>