

415 and 455 Lawn and Garden Tractors

TECHNICAL MANUAL

**John Deere
Worldwide Commercial and
Consumer Equipment Division**

TM1836 (Apr2000)



RECOGNIZE SAFETY INFORMATION



This is the safety-alert symbol. When you see this symbol on your machine or in this manual, be alert to the potential for personal injury.

Follow recommended precautions and safe servicing practices.

Understand Signal Words

A signal word—DANGER, WARNING, or CAUTION—is used with the safety-alert symbol. DANGER identifies the most serious hazards.

DANGER or WARNING safety signs are located near specific hazards. General precautions are listed on CAUTION safety signs. CAUTION also calls attention to safety messages in this manual.

REPLACE SAFETY SIGNS

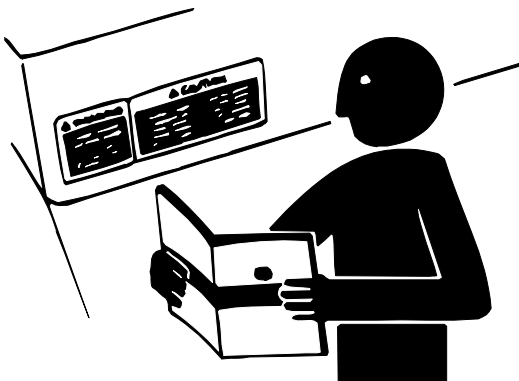

Replace missing or damaged safety signs. See the machine operator's manual for correct safety sign placement.

HANDLE FLUIDS SAFELY—AVOID FIRES

Be Prepared for Emergencies

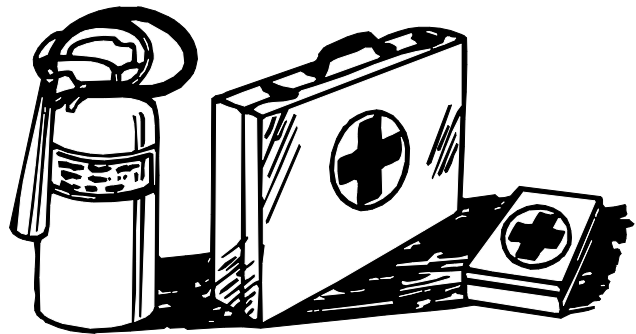

When you work around fuel, do not smoke or work near heaters or other fire hazards.

Store flammable fluids away from fire hazards. Do not incinerate or puncture pressurized containers.

Make sure machine is clean of trash, grease, and debris.

Do not store oily rags; they can ignite and burn spontaneously.

Be prepared if a fire starts.

Keep a first aid kit and fire extinguisher handy.

Keep emergency numbers for doctors, ambulance service, hospital, and fire department near your telephone.

USE CARE IN HANDLING AND SERVICING BATTERIES

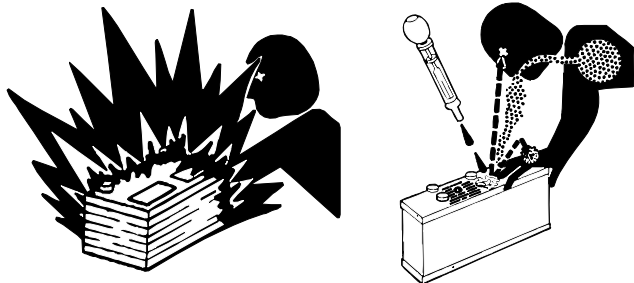

Prevent Battery Explosions

- Keep sparks, lighted matches, and open flame away from the top of battery. Battery gas can explode.
- Never check battery charge by placing a metal object across the posts. Use a voltmeter or hydrometer.
- Do not charge a frozen battery; it may explode. Warm battery to 16°C (60°F).

Prevent Acid Burns

- Sulfuric acid in battery electrolyte is poisonous. It is strong enough to burn skin, eat holes in clothing, and cause blindness if splashed into eyes.
- **Avoid acid burns by:**
 1. Filling batteries in a well-ventilated area.
 2. Wearing eye protection and rubber gloves.
 3. Avoiding breathing fumes when electrolyte is added.
 4. Avoiding spilling or dripping electrolyte.
 5. Using proper jump start procedure.
- **If you spill acid on yourself:**
 1. Flush your skin with water.
 2. Apply baking soda or lime to help neutralize the acid.
 3. Flush your eyes with water for 10—15 minutes.
 4. Get medical attention immediately.
- **If acid is swallowed:**
 1. Drink large amounts of water or milk.
 2. Then drink milk of magnesia, beaten eggs, or vegetable oil.
 3. Get medical attention immediately.

USE CARE AROUND HIGH-PRESSURE FLUID LINES



Avoid High-Pressure Fluids

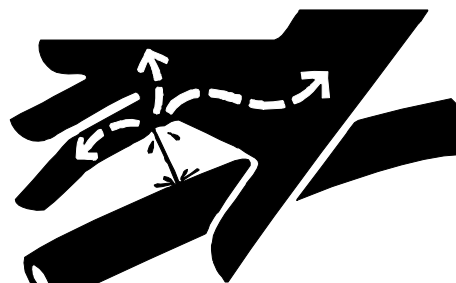

Escaping fluid under pressure can penetrate the skin causing serious injury.

Avoid injury from escaping fluid under pressure by stopping the engine and relieving pressure in the system before disconnecting or connecting hydraulic or other lines. Tighten all connections before applying pressure.

Search for leaks with a piece of cardboard. Protect hands and body from high-pressure fluids.

If an accident occurs, see a doctor immediately. Any fluid injected into the skin must be surgically removed within a few hours or gangrene may result. Doctors unfamiliar with this type of injury should reference a knowledgeable medical source. Such information is available from Deere & Company Medical Department in Moline, Illinois, U.S.A.

Avoid Heating Near Pressurized Fluid Lines



Flammable spray can be generated by heating near pressurized fluid lines, resulting in severe burns to yourself and bystanders. Do not heat by welding, soldering, or using a torch near pressurized fluid lines or other flammable materials. Pressurized lines can be accidentally cut when heat goes beyond the immediate flame area.

<https://www.ebooklibonline.com>

Hello dear friend!

Thank you very much for reading.

Enter the link into your browser.

The full manual is available for immediate download.

<https://www.ebooklibonline.com>



USE SAFE SERVICE PROCEDURES

Wear Protective Clothing

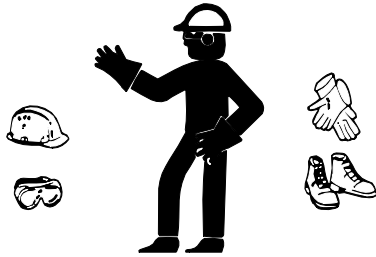

Wear close fitting clothing and safety equipment appropriate to the job.

Prolonged exposure to loud noise can cause impairment or loss of hearing. Wear a suitable hearing protective device such as earmuffs or earplugs to protect against objectionable or uncomfortable loud noises.

Operating equipment safely requires the full attention of the operator. Do not wear radio or music headphones while operating machine.

Service Machines Safely

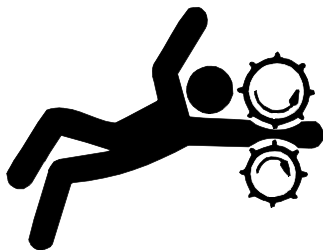

Tie long hair behind your head. Do not wear a necktie, scarf, loose clothing, or necklace when you work near machine tools or moving parts. If these items were to get caught, severe injury could result.

Remove rings and other jewelry to prevent electrical shorts and entanglement in moving parts.

Use Proper Tools

Use tools appropriate to the work. Makeshift tools and procedures can create safety hazards. Use power tools only to loosen threaded parts and fasteners. For loosening and tightening hardware, use the correct size tools. **DO NOT** use U.S. measurement tools on metric fasteners. Avoid bodily injury caused by slipping wrenches. Use only service parts meeting John Deere specifications.

Park Machine Safely

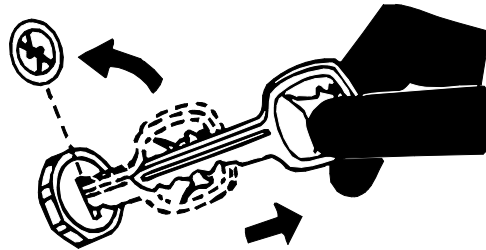

Before working on the machine:

1. Lower all equipment to the ground.
2. Stop the engine and remove the key.
3. Disconnect the battery ground strap.
4. Hang a "DO NOT OPERATE" tag in operator station.

Support Machine Properly and Use Proper Lifting Equipment

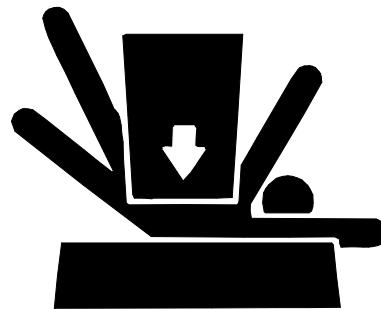

If you must work on a lifted machine or attachment, securely support the machine or attachment.

Do not support the machine on cinder blocks, hollow tiles, or props that may crumble under continuous load. Do not work under a machine that is supported solely by a jack. Follow recommended procedures in this manual.

Lifting heavy components incorrectly can cause severe injury or machine damage. Follow recommended procedure for removal and installation of components in the manual.

Work in Clean Area

Before starting a job:

1. Clean work area and machine.
2. Make sure you have all necessary tools to do your job.
3. Have the right parts on hand.
4. Read all instructions thoroughly; do not attempt shortcuts.

Using High—Pressure Washers

Directing pressurized water at electronic/electrical components or connectors, bearings, hydraulic seals, fuel injection pumps or other sensitive parts and components may cause product malfunctions. Reduce pressure and spray at a 45 to 90 degree angle.

Illuminate Work Area Safely

Illuminate your work area adequately but safely. Use a portable safety light for working inside or under the machine. Make sure the bulb is enclosed by a wire cage. The hot filament of an accidentally broken bulb can ignite spilled fuel or oil.

Work in Ventilated Area

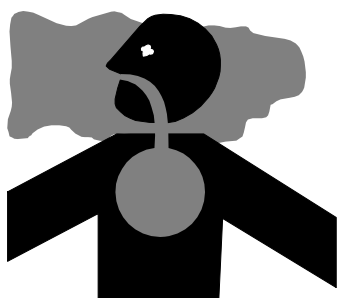

Engine exhaust fumes can cause sickness or death. If it is necessary to run an engine in an enclosed area, remove the exhaust fumes from the area with an exhaust pipe extension.

If you do not have an exhaust pipe extension, open the doors and get outside air into the area.

WARNING: California Proposition 65 Warning

Diesel engine exhaust and some of its constituents are known to the State of California to cause cancer, birth defects, and other reproductive harm.

Gasoline engine exhaust from this product contains chemicals known to the State of California to cause cancer, birth defects, or other reproductive harm.

Remove Paint Before Welding or Heating

Avoid potentially toxic fumes and dust. Hazardous fumes can be generated when paint is heated by welding, soldering, or using a torch. Do all work outside or in a well ventilated area. Dispose of paint and solvent properly. Remove paint before welding or heating. If you sand or grind paint, avoid breathing the dust. Wear an approved respirator. If you use solvent or paint stripper, remove stripper with soap and water before welding. Remove solvent or paint stripper containers and other flammable material from area. Allow fumes to disperse at least 15 minutes before welding or heating.

Avoid Harmful Asbestos Dust



Avoid breathing dust that may be generated when handling components containing asbestos fibers. Inhaled asbestos fibers may cause lung cancer.

Components in products that may contain asbestos fibers are brake pads, brake band and lining assemblies, clutch plates, and some gaskets. The asbestos used in these components is usually found in a resin or sealed in some way. Normal handling is not hazardous as long as airborne dust containing asbestos is not generated.

Avoid creating dust. Never use compressed air for cleaning. Avoid brushing or grinding material containing asbestos. When servicing, wear an approved respirator. A special vacuum cleaner is recommended to clean asbestos. If not available, apply a mist of oil or water on the material containing asbestos. Keep bystanders away from the area.

SERVICE TIRES SAFELY



Explosive separation of a tire and rim parts can cause serious injury or death.

Do not attempt to mount a tire unless you have the proper equipment and experience to perform the job. Always maintain the correct tire pressure. Do not inflate the tires above the recommended pressure. Never weld or heat a wheel and tire assembly. The heat can cause an increase in air pressure resulting in a tire explosion. Welding can structurally weaken or deform the wheel.

When inflating tires, use a clip-on chuck and extension hose long enough to allow you to stand to one side and NOT in front of or over the tire assembly. Use a safety cage if available.

Check wheels for low pressure, cuts, bubbles, damaged rims or missing lug bolts and nuts.



AVOID INJURY FROM ROTATING BLADES, AUGERS AND PTO SHAFTS

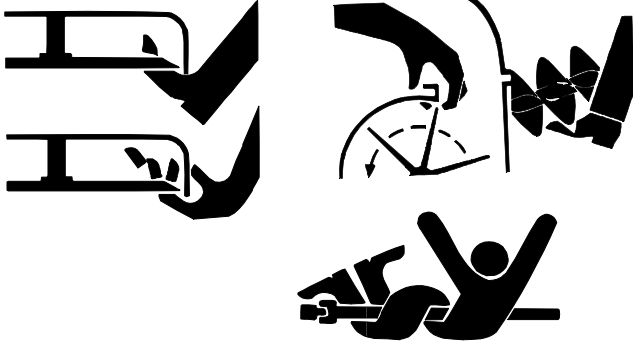

Keep hands and feet away while machine is running. Shut off power to service, lubricate, or remove mower blades, augers, or PTO shafts.

SERVICE COOLING SYSTEM SAFELY



Explosive release of fluids from pressurized cooling system can cause serious burns.

Shut off machine. Remove filler cap only when cool enough to touch with bare hands. Slowly loosen cap to first stop to relieve pressure before removing completely.

HANDLE CHEMICAL PRODUCTS SAFELY

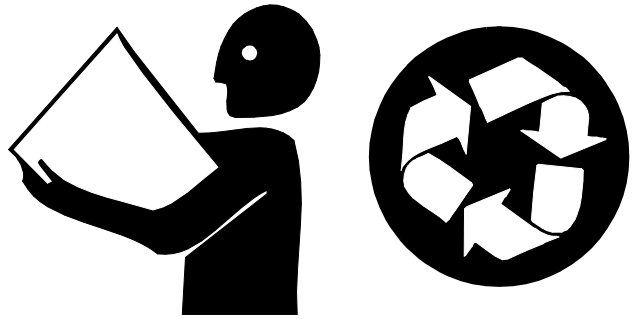

Direct exposure to hazardous chemicals can cause serious injury. Potentially hazardous chemicals used with John Deere equipment include such items as lubricants, coolants, paints, and adhesives.

A Material Safety Data Sheet (MSDS) provides specific details on chemical products: physical and health hazards, safety procedures, and emergency response techniques. Check the MSDS before you start any job using a hazardous chemical. That way you will know exactly what the risks are and how to do the job safely. Then follow procedures and recommended equipment.

Dispose of Waste Properly

Improperly disposing of waste can threaten the environment and ecology. Potentially harmful waste used with John Deere equipment includes such items as oil, fuel, coolant, brake fluid, filters, and batteries. Use leakproof containers when draining fluids. Do not use food or beverage containers that may mislead someone into drinking from them. Do not pour waste onto the ground, down a drain, or into any water source. Inquire on the proper way to recycle or dispose of waste from your local environmental or recycling center, or from your John Deere dealer.

LIVE WITH SAFETY



Before returning machine to customer, make sure machine is functioning properly, especially the safety systems. Install all guards and shields.

CONTENTS

SPECIFICATIONS AND INFORMATION



















	Page
METRIC FASTENER TORQUE VALUES	3
INCH FASTENER TORQUE VALUES	4
ENGINE OIL SPECIFICATIONS	5
DIESEL ENGINE OIL	5
BREAK-IN ENGINE OIL—DIESEL	6
HYDROSTATIC TRANSMISSION AND HYDRAULIC OIL	7
HYDROSTATIC TRANSMISSION AND HYDRAULIC OIL	7
COOLANT SPECIFICATIONS	8
DIESEL ENGINE COOLANT	8





This page intentionally left blank.

METRIC FASTENER TORQUE VALUES

Property Class and Head Markings	4.8		8.8		9.8		10.9			12.9		
												
Property Class and Nut Markings	5		10			10			12			
												TS1163



SIZE	Class 4.8				Class 8.8 or 9.8				Class 10.9				Class 12.9			
	Lubricated ^a		Dry ^a		Lubricated ^a		Dry ^a		Lubricated ^a		Dry ^a		Lubricated ^a		Dry ^a	
	N•m	lb-ft	N•m	lb-ft	N•m	lb-ft	N•m	lb-ft	N•m	lb-ft	N•m	lb-ft	N•m	lb-ft	N•m	lb-ft
M6	48	3.5	6	4.5	9	6.5	11	8.5	13	9.5	17	12	15	11.5	19	14.5
M8	12	8.5	15	11	22	16	28	20	32	24	40	30	37	28	47	35
M10	23	17	29	21	43	32	55	40	63	47	80	60	75	55	95	70
M12	40	29	50	37	75	55	95	70	110	80	140	105	130	95	165	120
M14	63	47	80	60	120	88	150	110	175	130	225	165	205	150	260	109
M16	100	73	125	92	190	140	240	175	275	200	350	225	320	240	400	300
M18	135	100	175	125	260	195	330	250	375	275	475	350	440	325	560	410
M20	190	140	240	180	375	275	475	350	530	400	675	500	625	460	800	580
M22	260	190	330	250	510	375	650	475	725	540	925	675	850	625	1075	800
M24	330	250	425	310	650	475	825	600	925	675	1150	850	1075	800	1350	1000
M27	490	360	625	450	950	700	1200	875	1350	1000	1700	1250	1600	1150	2000	1500
M30	675	490	850	625	1300	950	1650	1200	1850	1350	2300	1700	2150	1600	2700	2000
M33	900	675	1150	850	1750	1300	2200	1650	2500	1850	3150	2350	2900	2150	3700	2750
M36	1150	850	1450	1075	2250	1650	2850	2100	3200	2350	4050	3000	3750	2750	4750	3500

DO NOT use these hand torque values if a different torque value or tightening procedure is given for a specific application. Torque values listed are for general use only and include a ±10% variance factor. Check tightness of fasteners periodically. DO NOT use air powered wrenches.

Shear bolts are designed to fail under predetermined loads. Always replace shear bolts with identical grade.

Fasteners should be replaced with the same grade. Make sure fastener threads are clean and that you properly start thread engagement. This will prevent them from failing when tightening.











When bolt and nut combination fasteners are used, torque values should be applied to the **NUT** instead of the bolt head.

Tighten toothed or serrated-type lock nuts to the full torque value.

^a "Lubricated" means coated with a lubricant such as engine oil, or fasteners with phosphate and oil coatings. "Dry" means plain or zinc plated (yellow dichromate - Specification JDS117) without any lubrication.

Reference: JDS—G200.

INCH FASTENER TORQUE VALUES

SAE Grade and Head Markings	1 or 2 ^b No Marks 	5  5.1  5.2 	8  8.2 
	2 No Marks 	5  	8  

TS1162

SIZE	Grade 1				Grade 2 ^b				Grade 5, 5.1 or 5.2				Grade 8 or 8.2			
	Lubricated ^a		Dry ^a		Lubricated ^a		Dry ^a		Lubricated ^a		Dry ^a		Lubricated ^a		Dry ^a	
	N•m	lb-ft	N•m	lb-ft	N•m	lb-ft	N•m	lb-ft	N•m	lb-ft	N•m	lb-ft	N•m	lb-ft	N•m	lb-ft
1/4	3.7	2.8	4.7	3.5	6	4.5	7.5	5.5	9.5	7	12	9	13.5	10	17	12.5
5/16	7.7	5.5	10	7	12	9	15	11	20	15	25	18	28	21	35	26
3/8	14	10	17	13	22	16	27	20	35	26	44	33	50	36	63	46
7/16	22	16	28	20	35	26	44	32	55	41	70	52	80	58	100	75
1/2	33	25	42	31	53	39	67	50	85	63	110	80	120	90	150	115
9/16	48	36	60	45	75	56	95	70	125	90	155	115	175	130	225	160
5/8	67	50	85	62	105	78	135	100	170	125	215	160	215	160	300	225
3/4	120	87	150	110	190	140	240	175	300	225	375	280	425	310	550	400
7/8	190	140	240	175	190	140	240	175	490	360	625	450	700	500	875	650
1	290	210	360	270	290	210	360	270	725	540	925	675	1050	750	1300	975
1-1/8	470	300	510	375	470	300	510	375	900	675	1150	850	1450	1075	1850	1350
1-1/4	570	425	725	530	570	425	725	530	1300	950	1650	1200	2050	1500	2600	1950
1-3/8	750	550	950	700	750	550	950	700	1700	1250	2150	1550	2700	2000	3400	2550
1-1/2	1000	725	1250	925	990	725	1250	930	2250	1650	2850	2100	3600	2650	4550	3350

DO NOT use these hand torque values if a different torque value or tightening procedure is given for a specific application. Torque values listed are for general use only and include a ±10% variance factor. Check tightness of fasteners periodically. DO NOT use air powered wrenches.

Shear bolts are designed to fail under predetermined loads. Always replace shear bolts with identical grade.

Fasteners should be replaced with the same grade. Make sure fastener threads are clean and that you properly start thread engagement. This will prevent them from failing when tightening.

When bolt and nut combination fasteners are used, torque values should be applied to the **NUT** instead of the bolt head.

Tighten toothed or serrated-type lock nuts to the full torque value.

^a "Lubricated" means coated with a lubricant such as engine oil, or fasteners with phosphate and oil coatings. "Dry" means plain or zinc plated (yellow dichromate - Specification JDS117) without any lubrication.

^b "Grade 2" applies for hex cap screws (not hex bolts) up to 152 mm (6-in.) long. "Grade 1" applies for hex cap screws over 152 mm (6-in.) long, and for all other types of bolts and screws of any length.

Reference: JDS—G200.

ENGINE OIL SPECIFICATIONS

DIESEL ENGINE OIL

IMPORTANT: DO NOT USE GALVANIZED CONTAINERS—diesel fuel stored in galvanized containers reacts with zinc coating in the container to form zinc flakes. If fuel contains water, a zinc gel will also form. The gel and flakes will quickly plug fuel filters and damage fuel injectors and fuel pumps.

It is recommended that diesel fuel be stored **ONLY** in a clean, approved **POLYETHYLENE PLASTIC** container **WITHOUT** any metal screen or filter. This will help prevent any accidental sparks from occurring. Store fuel in an area that is well ventilated to prevent possible igniting of fumes by an open flame or spark, this includes any appliance with a pilot light.

IMPORTANT: Keep all dirt, scale, water or other foreign material out of fuel.

Keep fuel in a safe, protected area and in a clean, properly marked ("**DIESEL FUEL**") container. **DO NOT** use deicers to attempt to remove water from fuel. **DO NOT** depend on fuel filters to remove water from fuel. It is recommended that a water separator be installed in the storage tank outlet. **BE SURE** to properly discard unstable or contaminated diesel fuel and/or their containers when necessary.



BREAK-IN ENGINE OIL—DIESEL



IMPORTANT: ONLY use this specified break-in oil in rebuilt or remanufactured engines for the first 100 hours (maximum) of operation. DO NOT use SAE 15W-40 oil or oils meeting CCMC Specification D5—these oils will not allow rebuilt or remanufactured engines to break-in properly.

The following John Deere oil is **PREFERRED**:

- **BREAK-IN ENGINE OIL.**

John Deere BREAK-IN ENGINE OIL is formulated with special additives for aluminum and cast iron type engines to allow the power cylinder components (pistons, rings, and liners as well) to “wear-in” while protecting other engine components, valve train and gears, from abnormal wear. Engine rebuild instructions should be followed closely to determine if special requirements are necessary.

John Deere BREAK-IN ENGINE OIL is also recommended for non-John Deere engines, both aluminum and cast iron types.

If above preferred John Deere oil is not available, use a break-in engine oil meeting the following specification during the first 100 hours of operation:

- CCMC Specification D4 or higher.

IMPORTANT: After the break-in period, use the John Deere oil that is recommended for this engine.

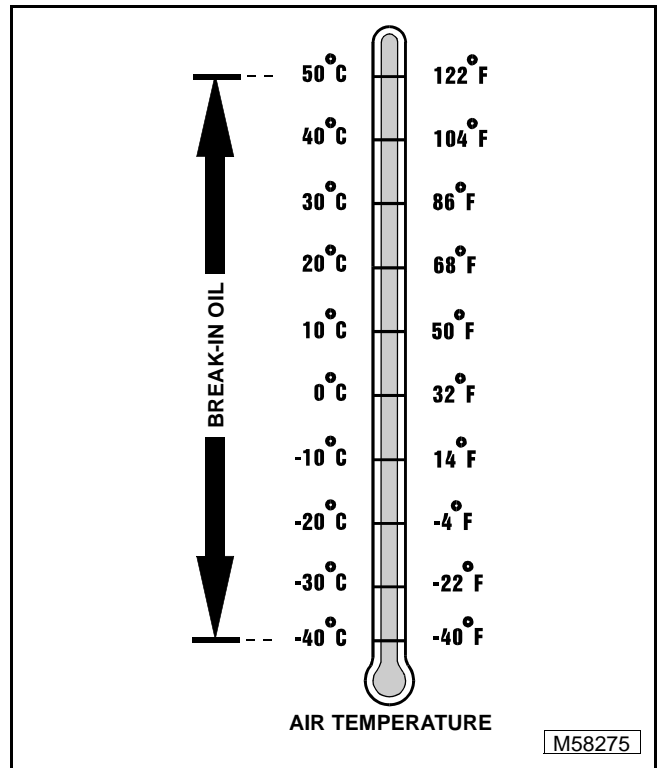

HYDROSTATIC TRANSMISSION AND HYDRAULIC OIL

HYDROSTATIC TRANSMISSION AND HYDRAULIC OIL

Use the appropriate oil viscosity based on these air temperature ranges. Operating outside of these recommended oil air temperature ranges may cause premature hydrostatic transmission or hydraulic system failures.

IMPORTANT: Mixing of **LOW VISCOSITY HY-GARD®** and **HY-GARD®** oils is permitted. **DO NOT** mix any other oils in this transmission. **DO NOT** use engine oil or "Type F" (Red) Automatic Transmission Fluid in this transmission. **DO NOT** use **BIO-HY-GARD®** in this transmission.

The following John Deere transmission and hydraulic oil is **PREFERRED**:

- **LOW VISCOSITY HY-GARD®—JDM J20D.**

The following John Deere oil is **also recommended** if above preferred oil is not available:

- **HY-GARD®—JDM J20C.**

Other oils may be used if above recommended John Deere oils are not available, provided they meet one of the following specifications:

- John Deere Standard JDM J20D;
- John Deere Standard JDM J20C.

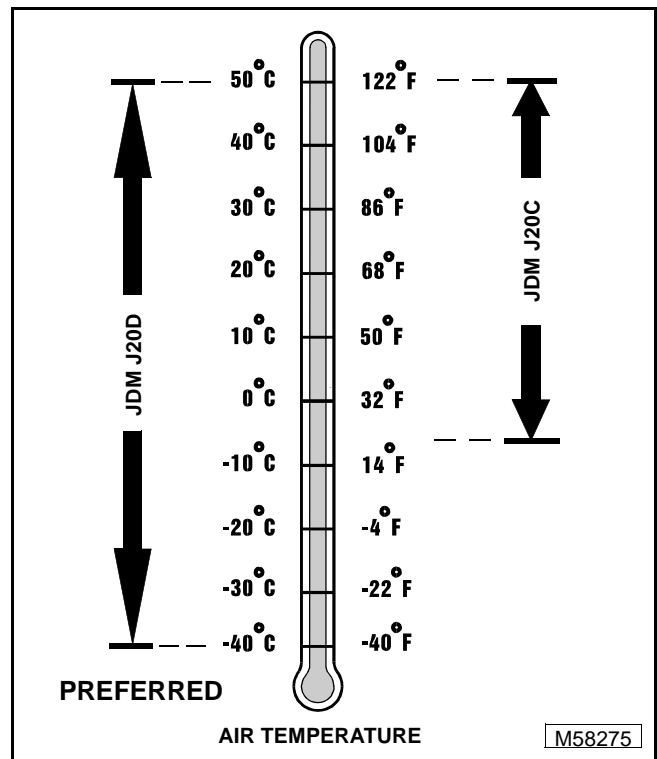

COOLANT SPECIFICATIONS

DIESEL ENGINE COOLANT



The engine cooling system when filled with a proper dilution mixture of anti-freeze and deionized or distilled water provides year-round protection against corrosion, cylinder or liner pitting, and winter freeze protection down to -37°C (-34°F).

The following John Deere coolant is **PREFERRED**:

- **PRE-DILUTED DIESEL ENGINE ANTI-FREEZE/ SUMMER COOLANT™ (TY16036).**

This coolant satisfies specifications for “Automobile and Light Duty Engine Service” and is safe for use in John Deere Lawn and Grounds Care/Golf and Turf Division equipment, including aluminum block gasoline engines and cooling systems.

The above preferred pre-diluted anti-freeze provides:

- adequate heat transfer
- corrosion-resistant chemicals for the cooling system
- compatibility with cooling system hose and seal material
- protection during extreme cold and extreme hot weather operations
- chemically pure water for better service life
- compliance with ASTM D4656 (JDM H24C2) specifications

If above preferred pre-diluted coolant is not available, the following John Deere concentrate is **recommended**:

- **DIESEL ENGINE ANTI-FREEZE/SUMMER COOLANT CONCENTRATE™ (TY16034).**

If either of above recommended engine coolants are available use any Automobile and Light Duty Engine Service **ethylene glycol base coolant**, meeting the following specification:

- ASTM D3306 (JDM H24C1).

Read container label completely before using and follow instructions as stated.

IMPORTANT: To prevent engine damage, **DO NOT** use pure anti-freeze or less than a 50% anti-freeze mixture in the cooling system. **DO NOT** mix or add any additives/conditioners to the cooling system in Lawn and Grounds Care/Golf and Turf Division equipment. Water used to dilute engine coolant concentrate must be of high quality—clean, clear, potable water (low in chloride and hardness—Table 1) is generally acceptable. **DO NOT** use salt water. Deionized or distilled water is ideal to use. Coolant that is not mixed to these specified levels and water purity can cause excessive scale, sludge deposits, and increased corrosion potential.

Water Quality

Property	Requirements
Total Solids, Maximum	340 ppm (20 grns/gal)
Total Hardness, Max.	170 ppm (10 grns/gal)
Chloride (as Cl), Max.	40 ppm (2.5 grns/gal)
Sulfate (as SO ₄), Max.	100 ppm (5.8 grns/gal)

Mix 50 percent anti-freeze concentrate with 50 percent distilled or deionized water. This mixture and the pre-diluted mixture (TY16036) will protect the cooling system down to -37°C(-34°F) and up to 108°C (226°F).

Certain geographical areas may require lower air temperature protection. See the label on your anti-freeze container or consult your John Deere dealer to obtain the latest information and recommendations.

CONTENTS

DIESEL ENGINE

	Page
SPECIFICATIONS—3TN66	3
GENERAL SPECIFICATIONS	3
TEST AND ADJUSTMENT SPECIFICATIONS	3
REPAIR SPECIFICATIONS	5
OTHER MATERIALS	13
SERVICE PARTS KITS	13
SPECIFICATIONS—3TNA72	14
GENERAL SPECIFICATIONS	14
TEST AND ADJUSTMENT SPECIFICATIONS	14
REPAIR SPECIFICATIONS	16
OTHER MATERIALS	24
SERVICE PARTS KITS	24
TESTS AND ADJUSTMENTS	25
AIR INTAKE SYSTEM LEAKAGE TEST	25
AIR FILTER RESTRICTION INDICATOR TEST	25
THROTTLE LEVER FRICTION ADJUSTMENT	26
THROTTLE CABLE ADJUSTMENT	26
BLEED FUEL SYSTEM	26
SLOW IDLE ADJUSTMENT	27
FAST IDLE ADJUSTMENT	27
FUEL CONTROL SCREW ADJUSTMENT	28
FUEL TRANSFER PUMP FLOW TEST	30
FUEL TRANSFER PUMP PRESSURE TEST	30
FUEL DRAIN-BACK TEST	31
FUEL INJECTION NOZZLE TEST (PINTLE-TYPE)	31
FUEL SHUTOFF SOLENOID ADJUSTMENT	33
INJECTION PUMP TIMING ADJUSTMENT	33
RADIATOR BUBBLE TEST	34
RADIATOR CAP PRESSURE TEST	34
THERMOSTAT OPENING TEST	35
COMPRESSION TEST	35
VALVE CLEARANCE CHECK AND ADJUSTMENT	36
VALVE LIFT CHECK	37
COOLANT TEMPERATURE SENSOR TEST	37
COOLING SYSTEM PRESSURE TEST	38
FAN/ALTERNATOR DRIVE BELT ADJUSTMENT	38
ENGINE OIL PRESSURE TEST	39
CAMSHAFT END PLAY CHECK	39
TIMING GEAR BACKLASH CHECK—3TN66 AND LATE MODELS 3TNA72	40
CONNECTING ROD SIDE PLAY CHECK	41
CONNECTING ROD BEARING CLEARANCE CHECK	41
CRANKSHAFT END PLAY CHECK	42
CRANKSHAFT MAIN BEARING CLEARANCE CHECK	43





	Page
REPAIR	44
DIESEL ENGINE—REMOVAL/INSTALLATION	44
FUEL INJECTION PUMP	45
FUEL CONTROL AND GOVERNOR LINKAGE	46
FUEL INJECTION NOZZLES	50
ROCKER ARM ASSEMBLY	52
TIMING GEAR HOUSING—3TN66	55
TIMING GEAR HOUSING—3TNA72	56
IDLER GEAR	57
CYLINDER HEAD AND VALVES	58
VALVE SEATS—GRINDING	63
VALVES—LAPPING	63
CAMSHAFT REMOVAL	64
CAMSHAFT INSTALLATION	64
CAMSHAFT INSPECTION/REPLACEMENT	65
CAM FOLLOWERS	67
PISTON-TO-CYLINDER HEAD CLEARANCE—MEASUREMENT	68
PISTON AND CONNECTING ROD	68
CRANKCASE EXTENSION HOUSING—3TNA72	74
CRANKSHAFT REAR OIL SEAL	75
CRANKSHAFT FRONT OIL SEAL	75
CRANKSHAFT AND MAIN BEARINGS	76
CYLINDER BORE	80
OIL PAN AND STRAINER—3TN66UJ	82
OIL PAN AND STRAINER—3TNA72	82
OIL PUMP	83
OIL PRESSURE REGULATING VALVE—3TN66UJ	84
OIL PRESSURE REGULATING VALVE—3TNA72	85

SPECIFICATIONS—3TN66

GENERAL SPECIFICATIONS

Slow Idle	1650 ± 150 rpm
Fast Idle	3350 ± 100 rpm
Compression	
Minimum Pressure (Min)	2448 kPa (355 psi)
Maximum Variation between Cylinders	490 kPa (71 psi)
Minimum Cranking Speed	250 rpm
Valve Clearance (Cold)	0.20 mm (0.008 in.)
Oil Pressure	
Pressure Sensor Activates	Below 69 kPa (10 psi)
Pressure (Fast Idle Min)	294 kPa (43 psi)
Radiator Cap	
Opening Pressure	83—97 kPa (12—14 psi)
Minimum Pressure	76 kPa (11 psi)
Thermostat	
Begin Opening	71°C (160°F)
Full Open	82°C (180°F)
Fan Drive Belt Deflection with 98 N (22 lb-force)	
Applied between Fan and Crank Drive Sheave	10—15mm (0.4—0.6 in.)
Fuel Pump	
Flow (Min)	450 mL (15 oz)/15 seconds
Pressure (Min)	172 kPa (25 psi)
Throttle Lever Friction Movement	18—35 N (4—8 lb-force)



TEST AND ADJUSTMENT SPECIFICATIONS

Air Intake System Leakage

Test Pressure	34—69 kPa (5—10 psi)
-------------------------	----------------------

Throttle Lever Friction

Force Required for Movement	18—35 N (4—8 lb-force)
---------------------------------------	------------------------

Idle

Slow Idle	1650 ± 150 rpm
Fast Idle	3350 ± 100 rpm

Fuel Transfer Pump

Test Temperature	15—25°C (59—77°F)
Minimum Flow before Filter	450 mL (15 oz)/15 seconds
Minimum Flow at Return Hose	200 mL (7 oz)/15 seconds
Minimum Pressure	172 kPa (25 psi)
Drain-Back Test Pressure (Maximum)	103 kPa (15 psi)

TEST AND ADJUSTMENT SPECIFICATIONS (Continued)

Fuel Injection Nozzle

Opening Pressure	11722 ± 480 kPa (1700 ± 70 psi)
Leakage at 11032 kPa (1600 psi)	Minimum of 10 Seconds with No Leakage
Chatter and Spray Pattern at 11722 ± 480 kPa (1700 ± 70 psi)	
Slow Hand Lever Movement	Chatter Sound
Slow Hand Lever Movement	Fine Stream Spray Pattern
Fast Hand Lever Movement	Fine Atomized Spray Pattern



Fuel Injection Pump Timing

Injection Pump Timing	13° BTDC (Before Top Dead Center)
Distance on Outer Surface of Crankshaft Pulley for	
Every 0.1 mm (0.004 in.) of Shim Thickness	1° or 1 mm (3/64 in.)
Engine Crankshaft Position	No. 1 Cylinder on TDC Compression Stroke
Total Shim Pack Thickness (New Shims)	0.5 mm (0.020 in.)
Mounting Nut Torque	20 N•m (180 lb-in.)
Delivery Valve Fitting Torque	42 N•m (31 lb-ft)

Radiator, Bubble Test

Maximum Air Pressure into Cylinder	2448 kPa (355 psi)
------------------------------------	--------------------

Radiator Cap Pressure

Opening Pressure	83—96 kPa (12—14 psi)
Minimum Pressure	76 kPa (11 psi)

Thermostat Opening

Begin Opening	71°C (160°F)
Full Open	82°C (180°F)
Minimum Lift Height	8 mm (0.310 in.)

Cooling System Pressure

Maximum Test Pressure	117 kPa (17 psi)
Minimum Pressure after 15 Seconds	90 kPa (14 psi)

Coolant Temperature Sensor

Continuity	107—113°C (225—235°F)
------------	-----------------------

Compression

Pressure (Min)	2448 kPa (355 psi)
Maximum Difference between Cylinders	490 kPa (71 psi)
Minimum Cranking Speed	250 rpm

Valve Clearance and Lift

Valve Clearance (Cold)	0.20 mm (0.008 in.)
Valve Lift (Intake and Exhaust)	7.5 mm (0.300 in.)

TEST AND ADJUSTMENT SPECIFICATIONS (Continued)

Fan/Alternator Drive Belt Tension

Applied Force	98 N (22 lb-force)
Deflection	10—15 mm (0.400—0.600 in.)

Engine Oil pressure

Pressure Sensor Activates	Below 69 kPa (10 psi)
Pressure (Fast Idle Min)	294 kPa (43 psi)

Camshaft End Play

Standard Clearance	0.05—0.20 mm (0.0020—0.0079 in.)
Wear Limit	0.40 mm (0.016 in.)

Timing Gear Backlash

Crankshaft Gear-to-Oil Pump Gear	0.11—0.19 mm (0.0043—0.0075 in.)
All <u>Except</u> Crankshaft Gear-to-Oil Pump Gear	0.04—0.12 mm (0.0016—0.0047 in.)
Wear Limit	0.20 mm (0.0079 in.)

Connecting Rod Side Play

Standard Clearance	0.20—0.40 mm (0.0079—0.0157 in.)
Wear Limit	0.55 mm (0.0217 in.)

Connecting Rod Bearing Clearance

Connecting Rod End Cap Screws Torque	23 N•m (203 lb-in.)
Standard Clearance	0.020—0.072 mm (0.0008—0.0028 in.)
Wear Limit	0.15 mm (0.0059 in.)

Crankshaft End Play

Standard Clearance	0.090—0.271 mm (0.004—0.011 in.)
Wear Limit	0.33 mm (0.0129 in.)

Crankshaft Main Bearing Clearance

Main Bearing Cap Cap Screw Torque	54 N•m (40 lb-ft)
Standard Clearance	0.020—0.072 mm (0.0008—0.0028 in.)
Wear Limit	0.15 mm (0.0059 in.)

REPAIR SPECIFICATIONS

Engine

Drive Shaft Coupler Screws Torque	40 N•m (30 lb-ft)
Mounting Bolts Torque	80 N•m (60 lb-ft)

Thermostat

Cover Cap Screws Torque	9 N•m (78 lb-in.)
-----------------------------------	-------------------



REPAIR SPECIFICATIONS (Continued)

Fuel Injection Pump

Mounting Nut Torque 20 N•m (180 lb-in.)

Fuel Control and Governor Linkage

Governor Shaft

OD (Minimum) 7.90 mm (0.311 in.)

Governor Shaft Bore ID

Wear Limit 8.15 mm (0.321 in.)

Clearance 0.18 mm (0.007 in.)

Sleeve

ID (Maximum) 8.20 mm (0.323 in.)

Injection Pump Camshaft OD

Wear Limit 7.90 mm (0.311 in.)

Clearance 0.15 mm (0.006 in.)



Fuel Injection Nozzles

Leak-Off Hose Nut Torque 40 N•m (30 lb-ft)

Nozzle Fitting Torque 40 N•m (30 lb-ft)

Nozzle Torque 50 N•m (37 lb-ft)

Separator Plate Nozzle Contact Surface Maximum Wear 0.10 mm (0.0039 in.)

Exhaust Manifold

Mounting Cap Screw and Nut Torque 11 N•m (97 lb-in.)

Intake Manifold

Mounting Cap Screw Torque 11 N•m (97 lb-in.)

Water Pump

Mounting Cap Screw Torque 26 N•m (19 lb-ft)

Fan Mounting Cap Screw Torque 11 N•m (96 lb-in.)

Plate-to-Housing Screw Torque 9 N•m (78 lb-in.)

Flywheel

Maximum Distortion (Flatness) 0.02 mm (0.0008 in.)

Mounting Cap Screw Torque 83 N•m (61 lb-ft)

Flywheel Plate

Mounting Cap Screw Torque 49 N•m (36 lb-ft)

REPAIR SPECIFICATIONS (Continued)

Rocker Arm Cover

Special Nut Torque 18 N•m (160 lb-in.)

Rocker Arm Assembly

Mounting Cap Screw and Nut Torque 26 N•m (19 lb-ft)

Rocker Arm Shaft OD

Standard 9.97—9.99 mm (0.3925—0.3933 in.)

Wear Limit 9.95 mm (0.3920 in.)

Rocker Arm and Shaft Support IDs

Standard 10.00—10.02 mm (0.3937—0.3945 in.)

Wear Limit 10.09 mm (0.3972 in.)

Clearance 0.14 mm (0.005 in.)

Push Rod Length

Standard 114—115 mm (4.488—4.528 in.)

Push Rod Bend

Wear Limit 0.08 mm (0.003 in.)

Stub Shaft

TIR Maximum 0.20 mm (0.008 in.)

Cap Screws Torque 59 N•m (44 lb-ft)

Maximum Mounting Flange Clearance (Flatness) 0.20 mm (0.008 in.)

Stub Shaft Cover Cap Screws Torque 26 N•m (19 lb-ft)

Timing Gear Cover

Fan Mounting Cap Screw Torque 11 N•m (96 lb-in.)

Cover Mounting Cap Screw Torque 9 N•m (78 lb-in.)

Crankshaft Pulley Cap Screw Torque 115 N•m (85 lb-ft)

Timing Gear Housing

Cap Screw Torque

Aluminum Housing-to-Block 9 N•m (78 lb-in.)

Cast Iron Housing-to-Block 11 N•m (96 lb-in.)

Idler Gear

Shaft OD

Standard 19.959—19.980 mm (0.786—0.787 in.)

Wear Limit 19.93 mm (0.785 in.)

Bushing ID

Standard 20.000—20.021 mm (0.787—0.788 in.)

Wear Limit 20.08 mm (0.791 in.)

Clearance 0.15 mm (0.0059 in.)



REPAIR SPECIFICATIONS (Continued)

Cylinder Head and Valves

Mounting Cap Screw Torque

First	11 N•m (97 lb-in.)
Second	22 N•m (195 lb-in.)
Final	34 N•m (25 lb-ft)

Cylinder Head Distortion

Standard	0.05 mm (0.002 in.) or less
Wear Limit	0.15 mm (0.006 in.)
Maximum Amount of Metal to Be Removed	0.20 mm (0.008 in.)

Valve Seat Width

Intake Valve	
Standard	1.15 mm (0.045 in.)
Wear Limit	1.65 mm (0.065 in.)
Exhaust Valve	
Standard	1.41 mm (0.056 in.)
Wear Limit	1.91 mm (0.075 in.)

Intake and Exhaust Valves

Valve Faces

Minimum Margin	0.51 mm (0.020 in.)
Exhaust Angle	45°
Intake Angle	30°

Valve Stem OD

Distance A	20 mm (0.787 in.)
Distance B	40 mm (1.575 in.)

Intake Valve Stem OD

Standard	5.46—5.48 mm (0.2149—0.2157 in.)
Wear Limit	5.40 mm (0.2126 in.)

Exhaust Valve Stem OD

Standard	5.44—5.46 mm (0.2142—0.2149 in.)
Wear Limit	5.40 mm (0.2126 in.)

Valve Recession

Intake Valve	0.40 mm (0.016 in.)
Exhaust Valve	0.85 mm (0.033 in.)

Valve Guides

Valve Guide ID

Maximum Clearance	0.20 mm (0.008 in.)
Standard	5.50—5.52 mm (0.216—0.217 in.)
Wear Limit	5.58 mm (0.220 in.)
Valve Guide Height	7 mm (0.276 in.)

Valve Springs

Maximum Free Length	28 mm (1.102 in.)
Maximum Spring Inclination	0.80 mm (0.032 in.)



REPAIR SPECIFICATIONS (Continued)

Valve Seat Angles

Intake Valve Seat	30°
Exhaust Valve Seat	45°
Lower Seat Surface (Intake and Exhaust)	70°
Upper Seat Surface (Intake and Exhaust)	15°

Camshaft

Mounting Cap Screw Torque	11 N•m (96 lb-in.)
Camshaft Side Gap	
Standard	0.05—0.15 mm (0.0020—0.0060 in.)
Wear Limit	0.40 mm (0.016 in.)
Camshaft Bend	
Maximum Bend	0.02 mm (0.001 in.)
Lobe Height	
Standard	29.97—30.03 mm (1.180—1.182 in.)
Wear Limit	29.75 mm (1.171 in.)
Journal OD	
Gear Housing and Flywheel Ends	
Standard	35.94—35.96 mm (1.4150—1.4157 in.)
Wear Limit	35.85 mm (1.4114 in.)
Intermediate	
Standard	35.91—35.94 mm (1.4138—1.4150 in.)
Wear Limit	35.85 mm (1.4114 in.)
Bushing ID	
Standard	36.000—36.065 mm (1.417—1.420 in.)
Wear Limit	36.10 mm (1.421 in.)
Clearance	0.18 mm (0.007 in.)
Bore ID	
Standard	36.000—36.025 mm (1.417—1.418 in.)
Wear Limit	36.10 mm (1.421 in.)
Clearance	0.18 mm (0.007 in.)

Cam Followers

OD	
Standard	17.950—17.968 mm (0.7067—0.7074 in.)
Wear Limit	17.93 mm (0.706 in.)
Bore ID	
Standard	18.00—18.018 mm (0.7087—0.7094 in.)
Wear Limit	18.05 mm (0.711 in.)
Clearance	0.032—0.068 mm (0.0013—0.0027 in.)

Pistons and Cylinder Head

Piston-to-Cylinder Head Clearance	0.59—0.74 mm (0.023—0.029 in.)
---	--------------------------------



REPAIR SPECIFICATIONS (Continued)

Piston and Connecting Rod

Connecting Rod Cap Screw Torque 23 N•m (17 lb-ft)

Connecting Rod Bearing ID

Standard 36.000—36.042 mm (1.417—1.419 in.)
 Wear Limit 37.07 mm (1.459 in.)
 Clearance 0.16 mm (0.006 in.)



Piston Ring Groove Clearance

First Compression Ring
 Standard 0.065—0.100 mm (0.0026—0.0039 in.)
 Wear Limit 0.20 mm (0.0079 in.)
 Second Compression Ring
 Standard 0.030—0.065 mm (0.0012—0.0026 in.)
 Wear Limit 0.20 mm (0.0079 in.)
 Oil Ring
 Standard 0.020—0.055 mm (0.0008—0.0022 in.)
 Wear Limit 0.20 mm (0.0079 in.)

Piston Ring End Gap

First Compression Ring and Oil Ring 0.15—0.35 mm (0.006—0.014 in.)
 Second Compression Ring 0.25—0.40 mm (0.010—0.016 in.)
 Wear Limit 1.50 mm (0.0591 in.)

Piston Pin

Pin OD
 Standard 19.991—20.00 mm (0.787—0.788 in.)
 Wear Limit 19.975 mm (0.786 in.)
 Bore ID
 Standard 20.00—20.008 mm (0.787—0.788 in.)
 Wear Limit 20.02 mm (0.788 in.)
 Clearance 0.045 mm (0.0018 in.)
 Bushing ID
 Standard 20.025—20.038 mm (0.788—0.789 in.)
 Wear Limit 20.10 mm (0.781 in.)
 Clearance 0.11 mm (0.0043 in.)

REPAIR SPECIFICATIONS (Continued)

Piston OD

Distance A	5 mm (0.197 in.)
Standard Size Piston	
Standard	65.927—65.957 mm (2.596—2.597 in.)
Wear Limit	65.85 mm (2.593 in.)
0.25 mm (0.010 in.) Oversize Piston	
Standard	66.18—66.21 mm (2.606—2.607 in.)
Wear Limit	66.10 mm (2.602 in.)
0.50 mm (0.020 in.) Oversize Piston	
Standard	66.43—66.46 mm (2.615—2.616 in.)
Wear Limit	66.35 mm (2.612 in.)

Crankshaft, Main Bearings and Flywheel

Crankshaft Rear Oil Seal	
Seal Case-to-Block Cap Screw Torque	11 N•m (96 lb-in.)
Oil Pan-to-Seal Case Cap Screw Torque	9 N•m (78 lb-in.)
Crankshaft and Main Bearings	
Main Bearing Cap Screw Torque	54 N•m (40 lb-ft)
Crankshaft Maximum Bend	0.02 mm (0.0007 in.)
Connecting Rod Journal OD	
Standard	35.97—35.98 mm (1.4161—1.4165 in.)
Wear Limit	35.92 mm (1.414 in.)
Main Bearing Journal OD	
Standard	39.97—39.98 mm (1.5736—1.5740 in.)
Wear Limit	39.92 mm (1.572 in.)
Main Bearing ID	
Standard	40.00—40.042 mm (1.575—1.577 in.)
Wear Limit	40.07 mm (1.578 in.)
Clearance	0.15 mm (0.0059 in.)

Cylinder Bore

Standard Size Bore ID	
Standard	66.00—66.03 mm (2.599—2.600 in.)
Wear Limit	66.20 mm (2.606 in.)
Clearance	0.25 mm (0.010 in.)
0.25 mm (0.010 in.) Oversize Bore ID	
Standard	66.25—66.28 mm (2.609—2.610 in.)
Wear Limit	66.45 mm (2.616 in.)
0.50 mm (0.020 in.) Oversize Bore ID	
Standard	66.50—66.53 mm (2.619—2.620 in.)
Wear Limit	66.70 mm (2.626 in.)
Cross-Hatch Pattern	
Deglazing	30—40°
Reboring	30—40°



REPAIR SPECIFICATIONS (Continued)

Oil Pan and Strainer

Mounting Cap Screw Torque

Oil Pan-to-Block	11 N•m (96 lb-in.)
Oil Pan-to-Seal Case	9 N•m (78 lb-in.)
Oil Pan-to-Timing Gear Housing	9 N•m (78 lb-in.)
Oil Strainer-to-Block	11 N•m (96 lb-in.)

Oil Pump



Mounting Cap Screw Torque	25 N•m (18 lb-ft)
Rotor Shaft OD-to-Backing Plate ID Clearance	
Standard	0.015—0.048 mm (0.0006—0.0035 in.)
Wear Limit	0.20 mm (0.0078 in.)
Rotor Recess	
Wear Limit	0.25 mm (0.010 in.)
Outer Rotor-to-Pump Body Clearance	
Standard	0.03—0.09 mm (0.0011—0.0035 in.)
Wear Limit	0.13 mm (0.0057 in.)
Inner-to-Outer Rotor Clearance	
Wear Limit	0.15 mm (0.0059 in.)

Oil Pressure Regulating Valve

Spring

Free Length	21.90—24.50 mm (0.860—0.960 in.)
Compressed Length	14.70 mm (0.580 in.) @12 N (2.7 lb-force)
Housing-to-Valve Body Retaining Nut Torque	30 N•m (22 lb-ft)

Fuel Injection Pump Camshaft

Bearing Retaining Screw Torque	20 N•m (180 lb-in.)
Minimum Lobe Height	30.90 mm (1.217 in.)

Freeze Plugs

Plug OD	30.218—30.30 mm (1.190—1.193 in.)
Hole ID	30.00—30.030 mm (1.181—1.182 in.)

OTHER MATERIALS

LOCTITE® PRODUCTS U.S./Canadian/
LOCTITE No.

- TY15130/ John Deere Form-In-Place
. Seals, rear oil seal case, crankcase gasket.
- TY9370/Thread Lock and Sealer Apply to threads of crankshaft pulley
- TY9477/(Medium Strength #242). Cap screws
- TY9369/Thread Lock and Sealer Apply to threads of studs in timing
(Low Strength #222). Gear housing

SERVICE PARTS KITS

The following kits are available through your parts catalog:

- Cylinder Block Gasket Kit
- Undersized Main Bearing Inserts
- Cylinder Head Gasket Kit
- Oversized Pistons and Rings
- Undersized Connecting Rod Bearing Inserts
- Fuel Injection Nozzle Shim Pack



SPECIFICATIONS—3TNA72

GENERAL SPECIFICATIONS

Slow Idle	1650 ± 150 rpm
Fast Idle	3350 ± 100 rpm
Compression	
Minimum Pressure (Min)	2448 kPa (355 psi)
Maximum Variation between Cylinders	490 kPa (71 psi)
Minimum Cranking Speed	250 rpm
Valve Clearance (Cold)	0.20 mm (0.008 in.)
Oil Pressure	
Pressure Sensor Activates	Below 69 kPa (10 psi)
Pressure (Fast Idle Min)	294 kPa (43 psi)
Radiator Cap	
Opening Pressure	83—97 kPa (12—14 psi)
Minimum Pressure	76 kPa (11 psi)
Thermostat	
Begin Opening	71°C (160°F)
Full Open	82°C (180°F)
Fan Drive Belt Deflection with 98 N (22 lb-force)	
Applied between Fan and Crank Drive Sheave	10—15mm (0.4—0.6 in.)
Fuel Pump	
Flow (Min)	450 mL (15 oz)/15 seconds
Pressure (Min)	172 kPa (25 psi)
Throttle Lever Friction Movement	18—35 N (4—8 lb-force)



TEST AND ADJUSTMENT SPECIFICATIONS

Air Intake System Leakage

Test Pressure	34—69 kPa (5—10 psi)
-------------------------	----------------------

Throttle Lever Friction

Force Required for Movement	18—35 N (4—8 lb-force)
---------------------------------------	------------------------

Idle

Slow Idle	1650 ± 150 rpm
Fast Idle	3350 ± 100 rpm
Fast Idle Adjustment Screw Lock Nut (CARB/EPA Engines) Torque	4 N•m (35 lb-in.)

Fuel Transfer Pump

Test Temperature	15—25°C (59—77°F)
Minimum Flow before Filter	450 mL (15 oz)/15 seconds
Minimum Flow at Return Hose	200 mL (7 oz)/15 seconds
Minimum Pressure	172 kPa (25 psi)
Drain-Back Test Pressure (Maximum)	103 kPa (15 psi)

TEST AND ADJUSTMENT SPECIFICATIONS (Continued)

Fuel Injection Nozzle

Opening Pressure	11722 ± 480 kPa (1700 ± 70 psi)
Leakage at 11032 kPa (1600 psi)	Minimum of 10 Seconds with No Leakage
Chatter and Spray Pattern at 11722 ± 480 kPa (1700 ± 70 psi)	
Slow Hand Lever Movement	Chatter Sound
Slow Hand Lever Movement	Fine Stream Spray Pattern
Fast Hand Lever Movement	Fine Atomized Spray Pattern

Fuel Injection Pump Timing

Injection Pump Timing	13° BTDC (Before Top Dead Center)
Distance on Outer Surface of Crankshaft Pulley for	
Every 0.1 mm (0.004 in.) of Shim Thickness	1° or 1 mm (3/64 in.)
Engine Crankshaft Position	No. 1 Cylinder on TDC Compression Stroke
Total Shim Pack Thickness (New Shims)	0.5 mm (0.020 in.)
Mounting Nut Torque	20 N•m (180 lb-in.)
Delivery Valve Fitting Torque	42 N•m (31 lb-ft)

Radiator, Bubble Test

Maximum Air Pressure into Cylinder	2448 kPa (355 psi)
------------------------------------	--------------------

Radiator Cap Pressure

Opening Pressure	83—96 kPa (12—14 psi)
Minimum Pressure	76 kPa (11 psi)

Thermostat Opening

Begin Opening	71°C (160°F)
Full Open	82°C (180°F)
Minimum Lift Height	8 mm (0.310 in.)

Cooling System Pressure

Maximum Test Pressure	117 kPa (17 psi)
Minimum Pressure after 15 Seconds	90 kPa (14 psi)

Coolant Temperature Sensor

Continuity	107—113°C (225—235°F)
------------	-----------------------

Compression

Pressure (Min)	2448 kPa (355 psi)
Maximum Difference between Cylinders	490 kPa (71 psi)
Minimum Cranking Speed	250 rpm

Valve Clearance and Lift

Valve Clearance (Cold)	0.20 mm (0.008 in.)
Valve Lift (Intake and Exhaust)	7.5 mm (0.300 in.)



TEST AND ADJUSTMENT SPECIFICATIONS (Continued)

Fan/Alternator Drive Belt Tension

Applied Force 98 N (22 lb-force)
 Deflection 10—15 mm (0.400—0.600 in.)

Engine Oil pressure

Pressure Sensor Activates Below 69 kPa (10 psi)
 Pressure (Fast Idle Min) 294 kPa (43 psi)



Camshaft End Play

Standard Clearance 0.05—0.20 mm (0.0020—0.0079 in.)
 Wear Limit 0.40 mm (0.016 in.)

Timing Gear Backlash

Crankshaft Gear-to-Oil Pump Gear 0.11—0.19 mm (0.0043—0.0075 in.)
 All Except Crankshaft Gear-to-Oil Pump Gear 0.04—0.12 mm (0.0016—0.0047 in.)
 Wear Limit 0.20 mm (0.0079 in.)

Connecting Rod Side Play

Standard Clearance 0.20—0.40 mm (0.0079—0.0157 in.)
 Wear Limit 0.55 mm (0.0217 in.)

Connecting Rod Bearing Clearance

Connecting Rod End Cap Screws Torque 23 N•m (203 lb-in.)
 Standard Clearance 0.020—0.072 mm (0.0008—0.0028 in.)
 Wear Limit 0.15 mm (0.0059 in.)

Crankshaft End Play

Standard Clearance 0.090—0.271 mm (0.004—0.011 in.)
 Wear Limit 0.33 mm (0.0129 in.)

Crankshaft Main Bearing Clearance

Main Bearing Cap Cap Screw Torque 79 N•m (58 lb-ft)
 Standard Clearance 0.020—0.072 mm (0.0008—0.0028 in.)
 Wear Limit 0.15 mm (0.0059 in.)

REPAIR SPECIFICATIONS

Engine

Drive Shaft Coupler Screws Torque 40 N•m (30 lb-ft)
 Mounting Bolts Torque 80 N•m (60 lb-ft)

Thermostat

Cover Cap Screws Torque 26 N•m (19 lb-ft)

REPAIR SPECIFICATIONS (Continued)

Fuel Injection Pump

Mounting Nut Torque 20 N•m (180 lb-in.)

Fuel Control and Governor Linkage

Governor Shaft

OD (Minimum) 7.90 mm (0.311 in.)

Governor Shaft Bore ID

Wear Limit 8.15 mm (0.321 in.)

Clearance 0.18 mm (0.007 in.)

Sleeve

ID (Maximum) 8.20 mm (0.323 in.)

Injection Pump Camshaft OD

Wear Limit 7.90 mm (0.311 in.)

Clearance 0.15 mm (0.006 in.)

Fuel Injection Nozzles

Leak-Off Hose Nut Torque 40 N•m (30 lb-ft)

Nozzle Fitting Torque 40 N•m (30 lb-ft)

Nozzle Torque 50 N•m (37 lb-ft)

Separator Plate Nozzle Contact Surface Maximum Wear 0.10 mm (0.0039 in.)

Exhaust Manifold

Mounting Cap Screw and Nut Torque 26 N•m (19 lb-ft)

Intake Manifold

Mounting Cap Screw Torque 11 N•m (97 lb-in.)

Water Pump

Mounting Cap Screw Torque 26 N•m (19 lb-ft)

Fan Mounting Cap Screw Torque 11 N•m (96 lb-in.)

Plate-to-Housing Screw Torque 9 N•m (78 lb-in.)

Flywheel

Maximum Distortion (Flatness) 0.02 mm (0.0008 in.)

Mounting Cap Screw Torque 83 N•m (61 lb-ft)

Flywheel Housing

Housing to Extension Cap Screw Torque 49 N•m (36 lb-ft)

Housing to Block Cap Screw Torque 49 N•m (36 lb-ft)

Flywheel Plate

Mounting Cap Screw Torque 49 N•m (36 lb-ft)



REPAIR SPECIFICATIONS (Continued)

Rocker Arm Cover

Special Nut Torque 18 N•m (160 lb-in.)

Rocker Arm Assembly

Mounting Cap Screw and Nut Torque 26 N•m (19 lb-ft)

Rocker Arm Shaft OD

Standard 11.96—11.98 mm (0.4711—0.4718 in.)

Wear Limit 11.95 mm (0.4706 in.)

Rocker Arm and Shaft Support IDs

Standard 12.00—12.02 mm (0.4724—0.4732 in.)

Wear Limit 12.09 mm (0.4759 in.)

Clearance 0.14 mm (0.005 in.)

Push Rod Length

Standard 141—142 mm (5.550—5.590 in.)

Push Rod Bend

Wear Limit 0.08 mm (0.003 in.)

Timing Gear Cover

Fan Mounting Cap Screw Torque 11 N•m (96 lb-in.)

Cover Mounting Cap Screw Torque 9 N•m (78 lb-in.)

Crankshaft Pulley Cap Screw Torque 115 N•m (85 lb-ft)

Timing Gear Housing

Cap Screw Torque

Aluminum Housing-to-Block 9 N•m (78 lb-in.)

Cast Iron Housing-to-Block 11 N•m (96 lb-in.)

Crankcase Extension-to-Housing Cap Screw Torque 22 N•m (16 lb-ft)

Idler Gear

Shaft OD

Standard 19.959—19.980 mm (0.786—0.787 in.)

Wear Limit 19.93 mm (0.785 in.)

Bushing ID

Standard 20.000—20.021 mm (0.787—0.788 in.)

Wear Limit 20.08 mm (0.791 in.)

Clearance 0.15 mm (0.0059 in.)



REPAIR SPECIFICATIONS (Continued)

Cylinder Head and Valves

Mounting Cap Screw Torque

First	19 N•m (14 lb-ft)
Second	38 N•m (28 lb-ft)
Final	61 N•m (45 lb-ft)

Cylinder Head Distortion

Standard	0.05 mm (0.002 in.) or less
Wear Limit	0.15 mm (0.006 in.)
Maximum Amount of Metal to Be Removed	0.20 mm (0.008 in.)

Valve Seat Width

Intake Valve	
Standard	1.44 mm (0.057 in.)
Wear Limit	1.98 mm (0.078 in.)
Exhaust Valve	
Standard	1.77 mm (0.070 in.)
Wear Limit	2.27 mm (0.089 in.)

Intake and Exhaust Valves

Valve Faces

Minimum Margin	0.51 mm (0.020 in.)
Exhaust Angle	45°
Intake Angle	30°

Valve Stem OD

Distance A	25 mm (0.984 in.)
Distance B	45 mm (1.772 in.)

Intake Valve Stem OD

Standard	6.94—6.96 mm (0.2732—0.2740 in.)
Wear Limit	6.90 mm (0.2717 in.)

Exhaust Valve Stem OD

Standard	6.94—6.96 mm (0.2732—0.2740 in.)
Wear Limit	6.90 mm (0.2717 in.)

Valve Recession

Intake Valve	0.50 mm (0.020 in.)
Exhaust Valve	0.85 mm (0.033 in.)

Valve Guides

Valve Guide ID

Maximum Clearance	0.20 mm (0.008 in.)
Standard	7.00—7.02 mm (0.275—0.276 in.)
Wear Limit	5.58 mm (0.220 in.)
Valve Guide Height	9 mm (0.354 in.)

Valve Springs

Maximum Free Length	28 mm (1.102 in.)
Maximum Spring Inclination	0.80 mm (0.032 in.)



REPAIR SPECIFICATIONS (Continued)

Valve Seats Angles

Intake Valve Seat	30°
Exhaust Valve Seat	45°
Lower Seat Surface (Intake and Exhaust)	70°
Upper Seat Surface (Intake and Exhaust)	15°

Camshaft

Mounting Cap Screw Torque	11 N•m (96 lb-in.)
-------------------------------------	--------------------

Camshaft Side Gap

Standard.	0.05—0.15 mm (0.0020—0.0060 in.)
Wear Limit	0.40 mm (0.016 in.)

Camshaft Bend

Maximum Bend	0.02 mm (0.001 in.)
------------------------	---------------------

Lobe Height

Standard.	33.95—34.05 mm (1.337—1.341 in.)
Wear Limit	33.75 mm (1.329 in.)

Journal OD

Gear Housing and Flywheel Ends

Standard.	39.94—39.96 mm (1.5724—1.5732 in.)
Wear Limit	39.85 mm (1.5689 in.)

Intermediate

Standard.	39.91—39.94 mm (1.5713—1.5724 in.)
Wear Limit	39.85 mm (1.5689 in.)

Bushing ID

Standard.	40.000—40.065 mm (1.575—1.577 in.)
Wear Limit	40.10 mm (1.579 in.)
Clearance.	0.18 mm (0.007 in.)

Bore ID

Standard.	40.000—40.025 mm (1.575—1.576 in.)
Wear Limit	40.10 mm (1.579 in.)
Clearance.	0.18 mm (0.007 in.)

Cam Followers

OD

Standard.	20.927—20.960 mm (0.8239—0.8276 in.)
Wear Limit	17.93 mm (0.706 in.)

Bore ID

Standard.	21.00—21.021 mm (0.8268—0.8276 in.)
Wear Limit	21.05 mm (0.829 in.)
Clearance.	0.040—0.094 mm (0.0016—0.0037 in.)

Pistons and Cylinder Head

Piston-to-Cylinder Head Clearance	0.61—0.9 mm (0.023—0.029 in.)
---	-------------------------------

REPAIR SPECIFICATIONS (Continued)

Piston and Connecting Rod

Connecting Rod Cap Screw Torque 23 N•m (17 lb-ft)

Connecting Rod Bearing ID

Standard 40.000—40.042 mm (1.575—1.577 in.)
 Wear Limit 40.07 mm (1.578 in.)
 Clearance 0.16 mm (0.006 in.)

Piston Ring Groove Clearance

First Compression Ring

Standard 0.075—0.110 mm (0.0030—0.0043 in.)
 Wear Limit 0.20 mm (0.0079 in.)

Second Compression Ring

Standard 0.030—0.065 mm (0.0012—0.0026 in.)
 Wear Limit 0.20 mm (0.0079 in.)

Oil Ring

Standard 0.020—0.055 mm (0.0008—0.0022 in.)
 Wear Limit 0.20 mm (0.0079 in.)

Piston Ring End Gap

First Compression Ring 0.10—0.25 mm (0.004—0.010 in.)
 Second Compression Ring 0.25—0.40 mm (0.010—0.016 in.)
 Oil Ring 0.15—0.35 mm (0.006—0.014 in.)
 Wear Limit 1.50 mm (0.0591 in.)

Piston Pin

Pin OD

Standard 20.991—21.00 mm (0.826—0.827 in.)
 Wear Limit 20.975 mm (0.825 in.)

Bore ID

Standard 21.00—21.009 mm (0.8268—0.8271 in.)
 Wear Limit 21.02 mm (0.828 in.)
 Clearance 0.045 mm (0.0018 in.)

Bushing ID

Standard 21.025—21.038 mm (0.8278—0.8282 in.)
 Wear Limit 21.10 mm (0.831 in.)
 Clearance 0.11 mm (0.0043 in.)



REPAIR SPECIFICATIONS (Continued)

Piston OD

Distance A	8 mm (0.315 in.)
Standard Size Piston	
Standard	71.922—71.952 mm (2.832—2.833 in.)
Wear Limit	71.81 mm (2.827 in.)
0.25 mm (0.010 in.) Oversize Piston	
Standard	72.17—72.20 mm (2.841—2.842 in.)
Wear Limit	72.06 mm (2.837 in.)
0.50 mm (0.020 in.) Oversize Piston	
Standard	72.42—72.45 mm (2.851—2.852 in.)
Wear Limit	72.31 mm (2.847 in.)



Crankcase Extension Housing

Flywheel Housing/Plate-to-Extension Cap Screw Torque	49 N•m (36 lb-ft)
Seal Case-to-Extension Cap Screw Torque	26 N•m (19 lb-ft)

Crankshaft, Main Bearings and Flywheel

Crankshaft Rear Oil Seal	
Seal Case-to-Block Cap Screw Torque	11 N•m (96 lb-in.)
Seal Case-to-Extension Cap Screw Torque	9 N•m (78 lb-in.)
Crankshaft and Main Bearings	
Main Bearing Cap Screw Torque	79 N•m (58 lb-ft)
Crankshaft Maximum Bend	0.02 mm (0.0007 in.)
Connecting Rod Journal OD	
Standard	39.97—39.98 mm (1.5736—1.5740 in.)
Wear Limit	39.92 mm (1.572 in.)
Main Bearing Journal OD	
Standard	43.97—43.98 mm (1.7311—1.7315 in.)
Wear Limit	39.92 mm (1.572 in.)
Main Bearing ID	
Standard	44.00—44.042 mm (1.732—1.734 in.)
Wear Limit	44.07 mm (1.735 in.)
Clearance	0.15 mm (0.0059 in.)

REPAIR SPECIFICATIONS (Continued)

Cylinder Bore

Standard Size Bore ID

Standard	72.00—72.03 mm (2.835—2.836 in.)
Wear Limit	72.20 mm (2.843 in.)
Clearance	0.28 mm (0.011 in.)

0.25 mm (0.010 in.) Oversize Bore ID

Standard	72.25—72.28 mm (2.845—2.846 in.)
Wear Limit	72.45 mm (2.852 in.)

0.50 mm (0.020 in.) Oversize Bore ID

Standard	72.50—72.53 mm (2.855—2.856 in.)
Wear Limit	72.70 mm (2.862 in.)

Cross-Hatch Pattern

Deglazing	30—40°
Reboring	30—40°

Oil Pan and Strainer

Mounting Cap Screw Torque

Oil Pan-to-Block	11 N•m (96 lb-in.)
Oil Pan-to-Seal Case	9 N•m (78 lb-in.)
Oil Pan-to-Timing Gear Housing	9 N•m (78 lb-in.)
Oil Strainer-to-Block	11 N•m (96 lb-in.)

Oil Pump

Mounting Cap Screw Torque	25 N•m (18 lb-ft)
---------------------------	-------------------

Rotor Shaft OD-to-Backing Plate ID Clearance

Standard	0.015—0.048 mm (0.0006—0.0035 in.)
Wear Limit	0.20 mm (0.0078 in.)

Rotor Recess

Wear Limit	0.25 mm (0.010 in.)
------------	---------------------

Outer Rotor-to-Pump Body Clearance

Standard	0.03—0.09 mm (0.0011—0.0035 in.)
Wear Limit	0.13 mm (0.0057 in.)

Inner-to-Outer Rotor Clearance

Wear Limit	0.15 mm (0.0059 in.)
------------	----------------------

Oil Pressure Regulating Valve

Spring

Free Length	43.50—48.50 mm (1.710—1.910 in.)
Compressed Length	27.50 mm (1.080 in.) with 20.5 N (4.6 lb-force)
Housing-to-Valve Body Retaining Nut Torque	30 N•m (22 lb-ft)
Housing-to-Engine Block Cap Screw Torque	27 N•m (20 lb-ft)

Fuel Injection Pump Camshaft

Bearing Retaining Screw Torque	20 N•m (180 lb-in.)
Minimum Lobe Height	30.90 mm (1.217 in.)



REPAIR SPECIFICATIONS—(Continued)

Freeze Plugs

Plug OD	30.218—30.30 mm (1.190—1.193 in.)
Hole ID	30.00—30.030 mm (1.181—1.182 in.)

OTHER MATERIALS

LOCTITE® PRODUCTS U.S./Canadian/
LOCTITE No.



TY15130/	John Deere Form-In-Place
.....	Seals, rear oil seal case, crankcase gasket.
TY9370/Thread Lock and Sealer	Apply to threads of crankshaft pulley
TY9477/(Medium Strength #242)	Cap screws
TY9369/Thread Lock and Sealer	Apply to threads of studs in timing
(Low Strength #222)	Gear housing

SERVICE PARTS KITS

The following kits are available through your parts catalog:

- Cylinder Block Gasket Kit
- Undersized Main Bearing Inserts
- Cylinder Head Gasket Kit
- Oversized Pistons and Rings
- Undersized Connecting Rod Bearing Inserts
- Fuel Injection Nozzle Shim Pack

TESTS AND ADJUSTMENTS

AIR INTAKE SYSTEM LEAKAGE TEST

Reason:

Check for leaks in air intake system.

Equipment:

- Air Pressure Regulator

Procedure:

1. Remove air cleaner restriction indicator/switch, if equipped, and install test fitting.
2. Connect air pressure regulator to manifold using hose and fitting from air cleaner.
3. Remove air cleaner cover and main filter element.
4. Put large plastic bag into and over end of main filter element. Install main filter element and cover.
5. Pressurize air intake system between **34—69 kPa (5—10 psi)**. If air intake system cannot be pressurized, turn engine slightly to close valves.
6. Spray soap solution over all connections from air cleaner to intake manifold or turbocharger, if equipped, and check for leaks.

IMPORTANT: When reinstalling starting aid nozzle, position arrow on nozzle pointing against intake air flow.

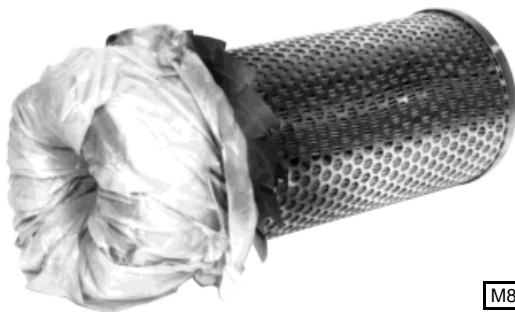

Results:

- Find leaks and repair or replace parts as necessary.

AIR FILTER RESTRICTION INDICATOR TEST

Reason:

Check operation of indicator and check intake system for leaks.

NOTE: If encountering performance problems (black smoke, etc.), check for plugged radiator cooling fins. Also check connecting hose is not damaged.

Procedure:

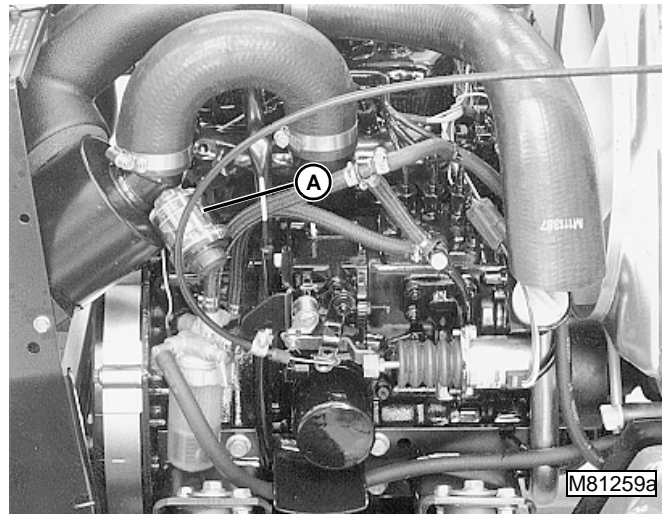

1. Release restriction indicator (A).
2. Start engine and run at wide-open throttle.

Results:

- If restriction indicator is at or above 635 mm (25 in.) vacuum, replace primary element.
- With new primary element installed, indicator at or above 500mm (20 in.) vacuum, replace secondary element.

NOTE: Normal restriction is approximately 380 mm (15 in.) vacuum.

Procedure:

1. Squeeze air supply hose to create a restriction.

Results:

- With engine at wide-open throttle and restriction applied, vacuum should increase and hold reading on indicator. If not, check for air leak in air intake hoses, or replace indicator.

THROTTLE LEVER FRICTION ADJUSTMENT

Reason:

To achieve smooth throttle lever movement with enough tension to maintain throttle setting.

Procedure:

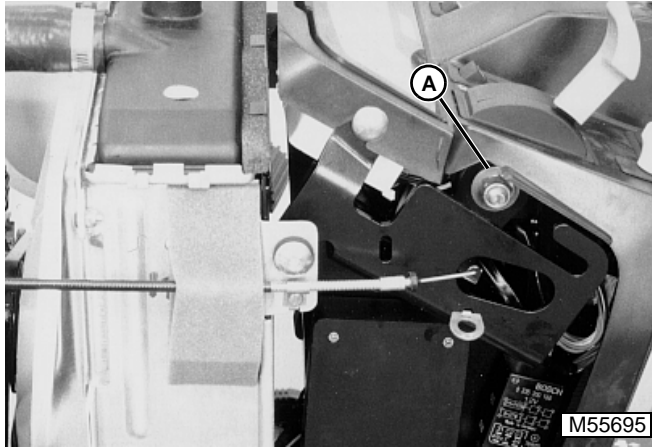

1. Adjust friction disks by tightening or loosening lock nut (A) until there is adequate friction to hold throttle in a set position.

NOTE: Make sure throttle cable is not binding or stuck.

THROTTLE CABLE ADJUSTMENT

Reason:

To insure that the throttle lever cable moves the governor lever completely to slow and to fast idle positions.

Procedure:

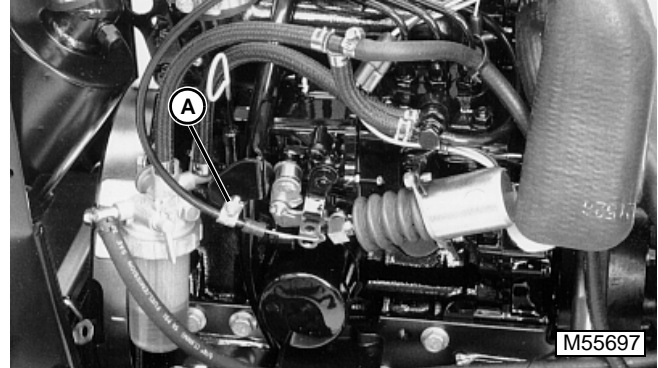

1. Loosen throttle cable clamp (A).
2. Move throttle lever on instrument panel towards fast idle position until the throttle lever cable end is 2—3 mm (0.080—0.120 in.) away from frame slot.
3. Hold throttle control lever against fast idle stop. Pull throttle cable tight. Tighten cable clamp.
4. Move throttle lever through full range. Check to be sure governor control lever moves through complete range and linkage is not binding.

BLEED FUEL SYSTEM

NOTE: These diesel engines are equipped with self-bleeding fuel injection systems. No bleed procedure is required.

SLOW IDLE ADJUSTMENT

Reason:

To achieve proper slow idle rpm setting. Provides adequate rpm to keep engine running smoothly without stalling.

Equipment:

- Digital Tachometer

Procedure:

1. Place a small piece of reflective tape on crankshaft pulley.

NOTE: Make sure air cleaner is clean and not restricted. Replace air cleaner element as necessary.

2. Start engine and run for 5 minutes.
3. Use a digital tachometer to check engine speed at flywheel.
4. Visually check that injection pump throttle lever is against slow idle stop screw. Check slow idle speed.
5. After slow idle speed adjustment, adjust throttle cable. (See THROTTLE CABLE ADJUSTMENT.)

Specifications:

Slow Idle Speed 1650 ±150 rpm

Results:

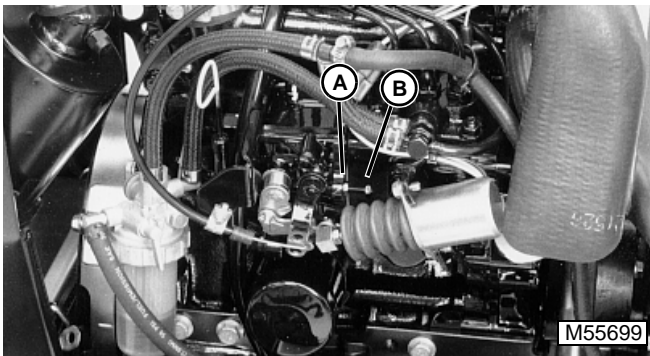

- If slow idle rpm is not according to specifications, loosen jam nut (A) and turn screw (B). After adjustment, hold adjustment screw stationary and tighten jam nut.

Procedure:

1. Place a small piece of reflective tape on crankshaft pulley.

NOTE: Make sure air cleaner is clean and not restricted. Replace air cleaner element as necessary.

2. Start engine and run for 5 minutes.
3. Use a digital tachometer to check engine speed at flywheel.
4. Push against injection pump throttle lever to insure it is up against fast idle stop screw. Check fast idle speed.
5. After fast idle speed adjustment, adjust throttle cable. (See THROTTLE CABLE ADJUSTMENT.)

Specifications:

Fast Idle Speed 3350 ±100 rpm

Results:

NOTE: Some adjustment can be made without removing sealed wire (A). Attempt to make the adjustment before removing wire.

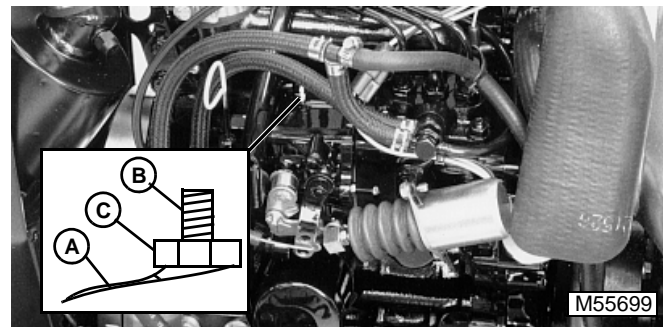

- If fast idle rpm is not according to specifications, remove fast idle acorn nut and loosen nut (C). Turn screw (B) until fast idle speed is correct. After adjustment, tighten nut (C) WITHOUT moving screw (B).
- Install acorn nut and new wire seal (A) and mark with a new paint stripe.
- If engine still does not meet fast idle specifications, have pump inspected by an Authorized Diesel Service (ADS) center.



FAST IDLE ADJUSTMENT

Reason:

To achieve proper fast idle speed setting. This provides proper speed for PTO operation and insures that engine is running at proper speed for peak performance.

Equipment:

- Digital Tachometer

FUEL CONTROL SCREW ADJUSTMENT

IMPORTANT: Always replace shims between fuel injection pump and injection pump housing whenever pump has been removed. (See INJECTION PUMP TIMING ADJUSTMENT.)

Reason:

To ensure engine performs at peak power with optimum torque rise recovery under load.

Equipment:

- Spring M72632

Procedure:

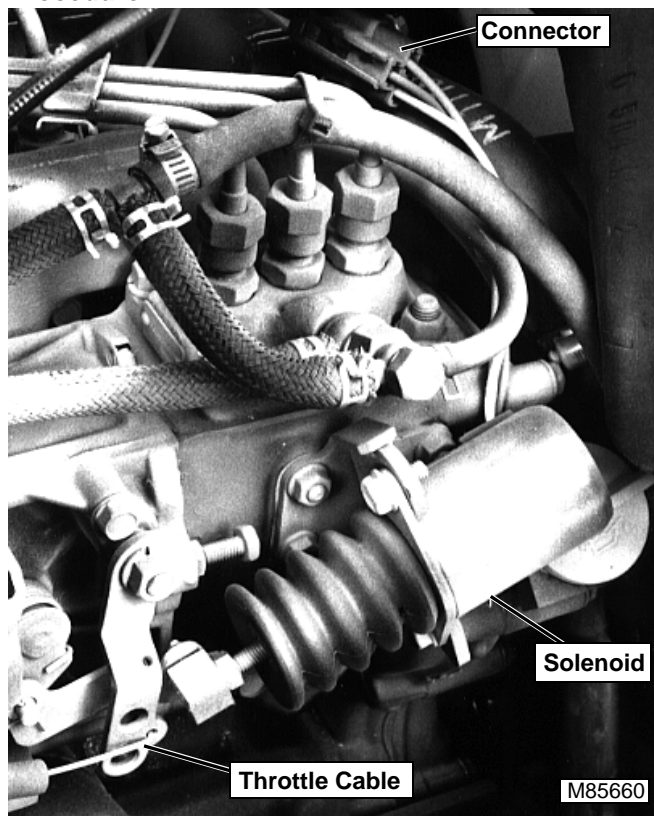

1. Disconnect solenoid from wiring harness and shutoff lever. Remove solenoid from bracket.
2. Disconnect throttle cable from throttle lever.
3. Remove fuel filter from bracket WITHOUT disconnecting fuel lines.
4. Remove air cleaner assembly and intake hose.

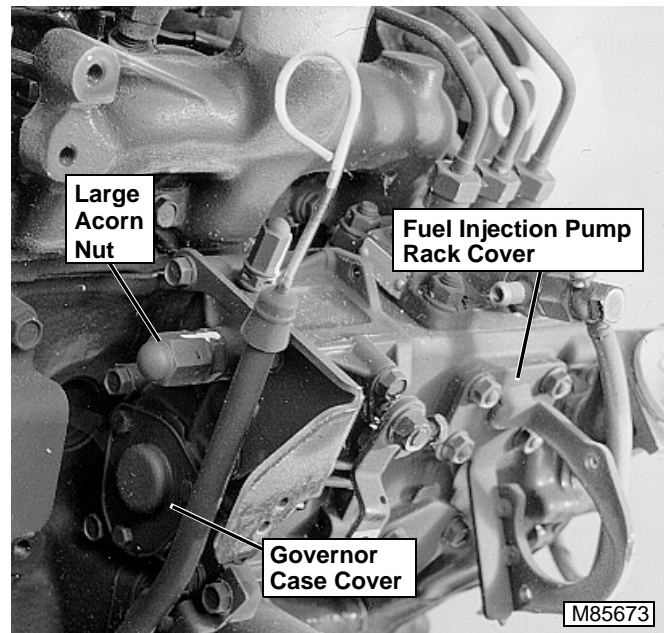

5. Remove governor case cover, fuel injection pump rack cover, and large acorn nut.

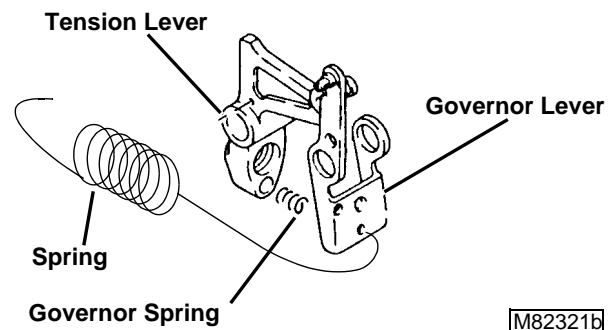
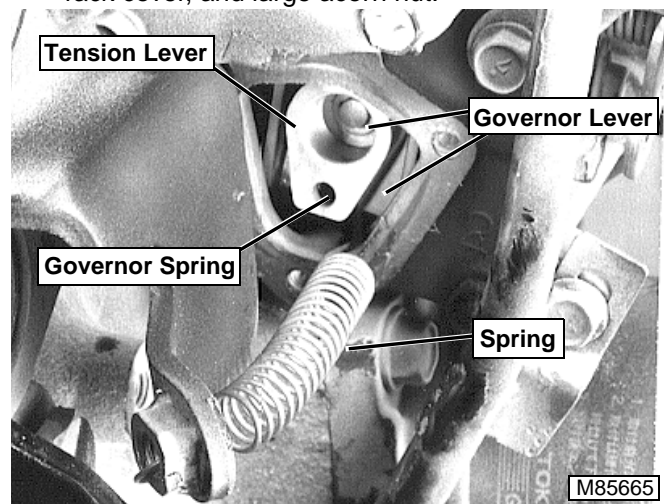

NOTE: Ends of spring may have to be bent to hold governor lever and to attach to fuel filter bracket.

6. Install M72632 spring to compress the governor spring between the tension lever and the governor lever.

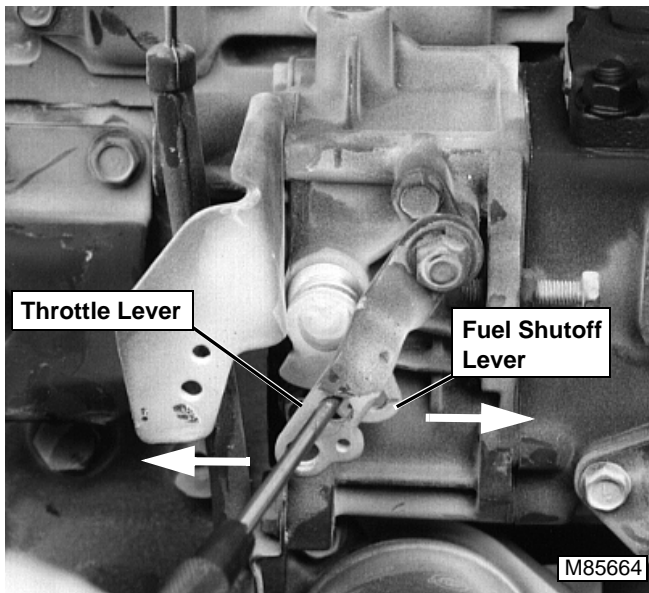

7. Hold fuel shutoff lever fully counterclockwise and at the same time hold throttle lever fully clockwise. Insert a punch to hold both levers in position or tie off each with strong wires.

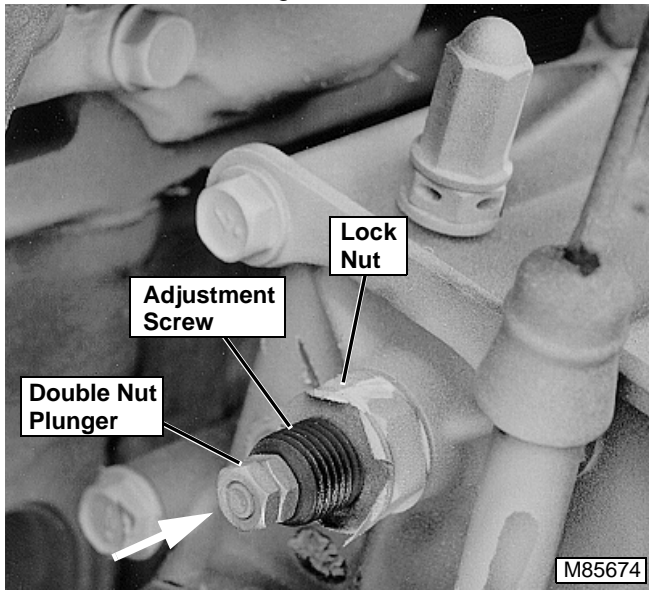

IMPORTANT: DO NOT tamper with double nuts or engine warranty will be voided. These are pre-set by engine manufacturer and must not be altered.

Press in fully on double nut plunger assembly any time adjustment is being made.

8. Loosen lock nut to allow movement of adjustment screw.

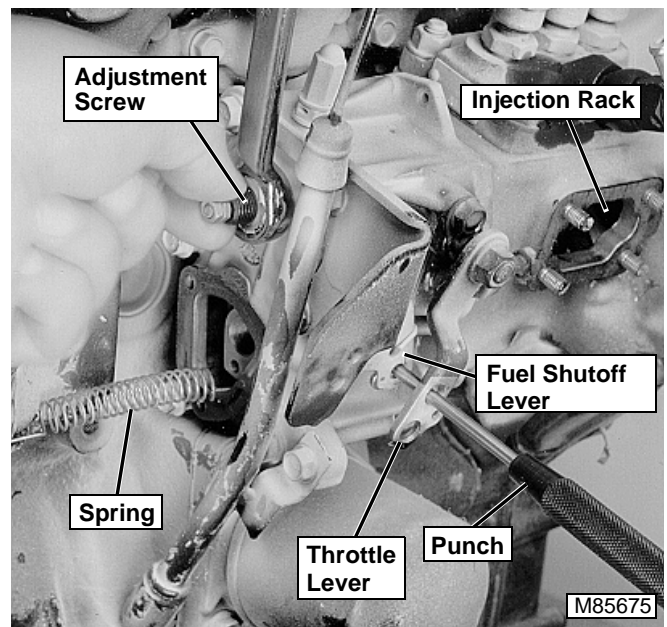

9. Use a helper at this point to perform adjustment.
10. Use a punch or strong wires to hold fuel shutoff lever fully counterclockwise and throttle lever fully clockwise.

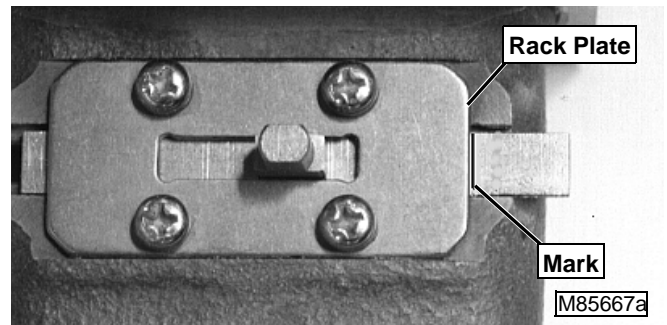

IMPORTANT: Fuel injection rack should have an alignment mark on it. If rack is NOT MARKED, fuel injection pump MUST BE sent to an Authorized Diesel Service (ADS) center to be calibrated and re-marked. Instruct ADS technician that there must be only one distinguishable alignment mark on rack.

11. Push in on double nut plunger assembly and at the same time turn adjustment screw to align mark. When mark is aligned with right edge of rack plate, tighten lock nut while keeping adjustment screw stationary.
12. Check that alignment mark has not moved. Re-adjust if necessary.
13. Remove spring and punch or wires.

IMPORTANT: BE SURE to install new gaskets on governor case cover and fuel injection pump rack cover (part of solenoid mounting bracket).

14. Assemble parts in reverse order of removal.
15. Install new wire seal to acorn nuts and mark them with a new paint stripe.

FUEL TRANSFER PUMP FLOW TEST

Reason:

To determine proper fuel flow from transfer pump.

Equipment:

- Graduated Container

Connections:

1. Engage park brake. PTO switch off.

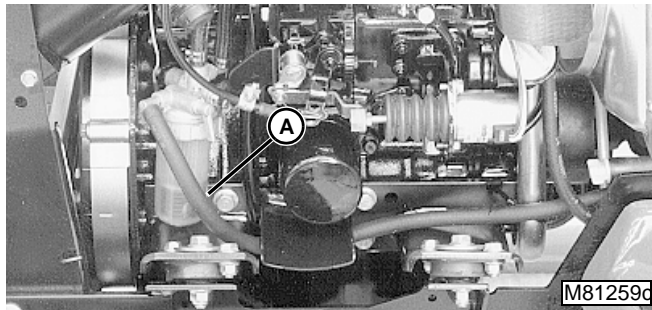

2. Disconnect fuel supply hose (A) from filter inlet and put end in a graduated container.

Procedure:

1. Turn key on for 15 seconds.
2. Compare collected fuel amount to specification.

Connections:

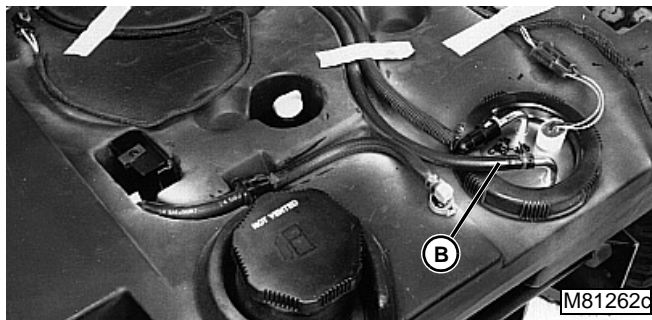

1. Reconnect supply hose to filter. Disconnect fuel return hose (B) from filter to injection pump and put end in a graduated container.

Procedure:

1. Turn key on for 15 seconds.
2. Compare collected fuel amount to specification.
3. Reconnect fuel shutoff solenoid connector.
4. Reconnect fuel lines.

Specifications (Factory Observed Flow):

Fuel Temperature for Test . . . 15—25°C (59—77°F)
Minimum Fuel Flow before Filter . . . 450 mL (15 oz)
Flow at Return Hose 200 mL (7 oz)

Results:

- If fuel flow at transfer pump is below minimum, check for pinched or deteriorated fuel lines between fuel tank and pump. Also check fuel tank vent for plugging or tank pickup screens for possible restriction. Replace lines and screen as necessary.
- If fuel flow is still below minimum, replace transfer pump.
- If output at return hose is low, replace filter element and repeat test. Check for pinched or restricted return hoses.

FUEL TRANSFER PUMP PRESSURE TEST

Reason:

To determine condition of transfer pump.

Equipment:

- JTO3115 Pressure Gauge (100 psi).
- Small piece of fuel line

Connections:

1. Engage park brake. PTO switch off.



2. Disconnect hose from transfer pump outlet (A). Connect pressure gauge to transfer pump outlet.

Procedure:

1. Turn key on. Observe pressure reading.
2. Reconnect fuel lines.

Specifications:

Fuel Temperature for Test 15—25°C (59—77°F)
Minimum Fuel Pressure. 172 kPa (25 psi)
Factory Observed Pressure 248kPa (36 psi)

Results:

- If pressure is below minimum, replace transfer pump.

FUEL DRAIN-BACK TEST

Reason:

Determines if air is entering the fuel system at connections, allowing fuel to siphon back to tank.

Procedure:

1. Disconnect fuel supply line and return line at fuel tank.

IMPORTANT: Fuel return line MUST extend below fuel level in fuel tank before performing this test. Fill fuel tank if necessary.

2. Drain all fuel from the system, including fuel supply pump, injection pump, filter(s) and water separator, if equipped.
3. Plug end of fuel return hose.
4. Pressurize fuel system at fuel supply line to a maximum pressure of **103 kPa (15 psi)**.
5. Apply liquid soap and water solution to all joints and connections in the fuel system and inspect for leaks.

Results:

- Find leaks and repair or replace parts as necessary.

FUEL INJECTION NOZZLE TEST (PINTLE-TYPE)



CAUTION

Escaping fluid under pressure can penetrate the skin causing serious injury. Avoid the hazard by relieving pressure before disconnecting hydraulic or other lines. Tighten all connections before applying pressure. Search for leaks with a piece of cardboard. Protect hands and body from high pressure fluids.

If an accident occurs, see a doctor immediately. Any fluid injected into the skin must be surgically removed within a few hours or gangrene may result. Doctors unfamiliar with this type of injury should reference a knowledgeable source. Such information is available from the Deere & Company Medical Department in Moline, Illinois, U.S.A.

Reason:

To determine opening pressure, leakage, chatter and spray pattern of the fuel injection nozzle.

Equipment:

- D01109AA Diesel Fuel Injection Nozzle Tester
- D01110AA Adapter Set
- 36352 Fuel Line Assembly
- 23621 Straight Adapter
- 23622 Straight Adapter
- 23617 90° Adapter
- Container

Connections:

- Connect fuel injection nozzle to D01109AA Diesel Fuel Injection Nozzle Tester using parts from D01110AA Adapter Set and 23622 Straight Adapter.



IMPORTANT: Use clean filtered diesel fuel when testing injection nozzles to get best test results.

Procedure 1:

Test fuel injection nozzle **opening pressure** following the nozzle tester manufacturer's instructions.

Specifications:

Opening Pressure **11722—480 kPa**
(1700—70 psi)

Results:

- If pressure reading does not meet specification, disassemble injection nozzle and inspect nozzle assembly for contamination or stuck valve. If necessary, add or remove shims to change opening pressure.

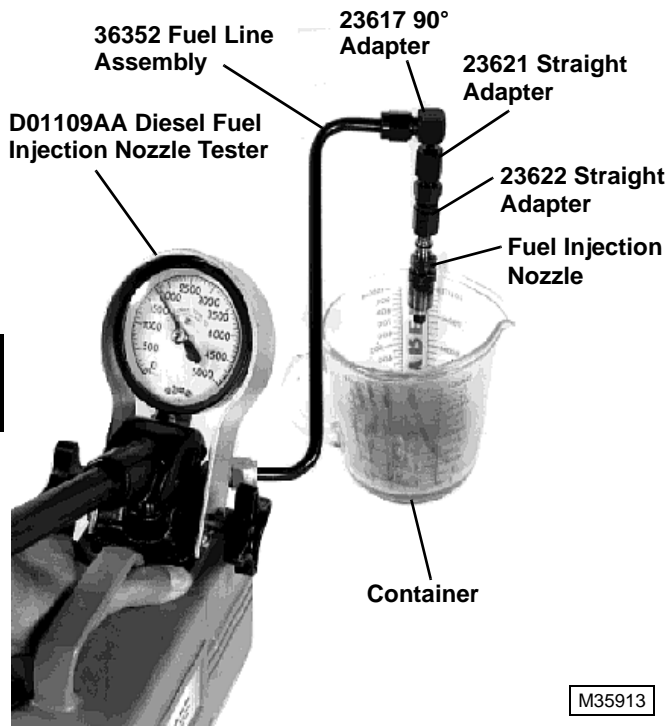

Specifications:

- Slow Hand Lever Movement Chatter Sound
- Slow Hand Lever Movement Fine Stream Spray Pattern
- Fast Hand Lever Movement. Fine Atomized Spray Pattern

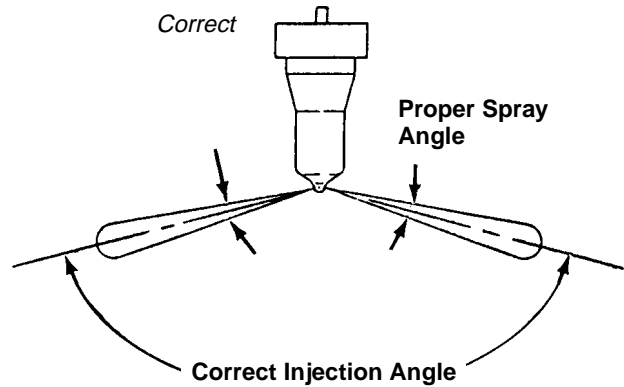

Poor

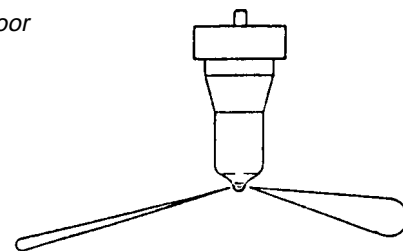

M82121A

Procedure 2:

Test fuel injection nozzle **leakage** following the nozzle tester manufacturer's instructions.

1. Dry nozzle completely using a lint-free cloth.
2. Pressurize nozzle to **11032 kPa (1600 psi)**.
3. Watch for leakage from nozzle spray orifice. Leakage time should be a minimum of **10 seconds**.

Results:

- If leakage time does not meet specification, disassemble injection nozzle and inspect nozzle assembly for contamination. Inspect valve seating surface. Replace nozzle assembly if necessary.

Procedure 3:

Test fuel injection nozzle **chatter and spray pattern** following the nozzle tester manufacturer's instructions.

1. Pressurize nozzle to **11722 ± 480 kPa (1700 ± 70 psi)**.
2. Listen for “chatter” sound and watch spray pattern.

Results:

- If nozzle chatter or spray pattern do not meet specifications, disassemble injection nozzle and inspect nozzle assembly for contamination. Inspect valve seating surface. Replace nozzle assembly if necessary.
- If there is excessive difference in spray angle or injection angle, incomplete atomization or sluggish starting/stopping of injection, disassemble injection nozzle and inspect nozzle assembly for contamination. Replace nozzle assembly if necessary.

FUEL SHUTOFF SOLENOID ADJUSTMENT

Reason:

To ensure that fuel shutoff solenoid retracts fully, moving the injection pump shutoff control lever far enough to allow full rack travel.

Procedure:

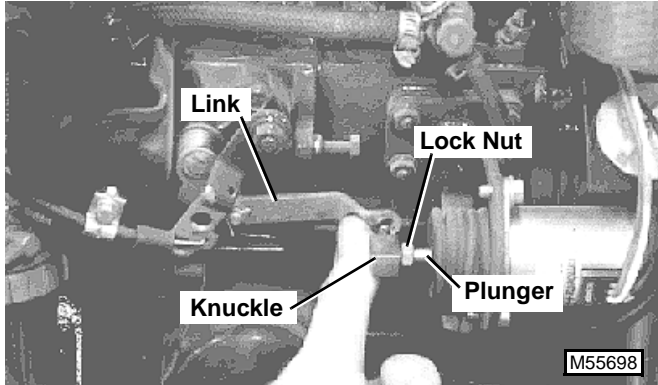

1. Loosen lock nut.
2. Disconnect link from solenoid.
3. Hold solenoid plunger bottomed in solenoid body.
4. Move link toward solenoid until it stops.
5. Turn plunger rod in or out of knuckle until knuckle and link holes line up. Turn out two additional turns. The additional turns insure that the solenoid bottoms out before the linkage.
6. Reassemble the knuckle to the shutoff linkage.

NOTE: Total turns of knuckle should NOT EXCEED 5 FULL turns from where hole and knuckle stud line up. Additional turns may limit FULL delivery.

7. If solenoid still does not pull in, loosen lock nut and turn knuckle out one FULL turn at a time. After each full turn, check for solenoid to pull in when key is turned on.
8. Assemble and check for free movement when key switch is turned on. Also check that linkage returns completely to the stop position when key switch is turned off.

INJECTION PUMP TIMING ADJUSTMENT

ATTENTION!

Do not attempt to rebuild or adjust carburetor unless you are a factory trained technician with authorization to service California Air Resources Board/Environmental Protection Agency (CARB/EPA) Certified engines.

Reason:

To make sure that injection pump timing is set to manufacturer's specification.

Procedure:

IMPORTANT: In most instances the timing should not have to be checked. A general rule of thumb is that if the engine performed well at one time, and then performance changed, timing is not the problem. Timing once set by shims, will not change during the life of the engine.

Check and adjust timing only as the last option. Check fuel, fuel supply system, injectors, air intake system and cylinder compression before continuing.

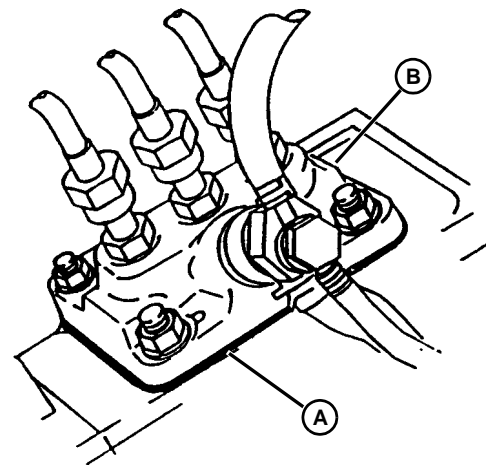

M35865a

1. Remove fuel injection pump cover (B).
2. Install shim (A).
3. Install fuel injection pump cover (B).

Specifications:

Shim	0.5 mm (0.02 in.)
Mounting Nut Torque	20 N•m (180 lb-in.)
Shim Thickness	Injection Timing
1.1 mm	11° & 12° BTDC
0.9 mm	13° BTDC
0.8 mm	14° & 15° BTDC
0.7 mm	16° BTDC
0.6 mm	18° BTDC
0.5 mm	20° BTDC



RADIATOR BUBBLE TEST

Reason:

To determine if compression pressure is leaking from cylinder.

Equipment:

- JDG472 Adapter

Procedure:

1. With coolant at proper level and radiator cap tight, run engine for 5 minutes to bring to operating temperature.
2. Remove cap from recovery tank.
3. Check for bubbles coming from overflow hose at bottom of tank.
If bubbles are present, isolate source of compression leak:
 - Remove injection nozzles.
 - Install JDG472 Adapter in injection port of cylinder to be tested.
 - Move piston to bottom of stroke with intake and exhaust valves closed.
 - Connect hose from compressed air source to adapter.
 - Apply air pressure of **2448 kPa (355 psi) maximum** into cylinder:
 - Check for bubbles in recovery tank or air escaping from muffler, air cleaner or oil fill opening.
 - Repeat for each cylinder.

Results:

- If bubbles are present, check for cracks in cylinder head and block. Check for damaged head gasket.
- If air escapes from muffler, check for worn exhaust valve.
- If air escapes from air cleaner, check for worn intake valve.
- If air escapes from engine oil fill, check for worn piston rings.

RADIATOR CAP PRESSURE TEST

Reason:

Test radiator cap for operating in correct pressure range.

Equipment:

- D05104ST Cooling System Pressure Pump
- JDG692 Radiator Pressure Test Kit (Adapters)

Procedure:

1. Install radiator cap on pressure pump.
2. Apply pressure. Pressure valve in cap should open according to specifications.

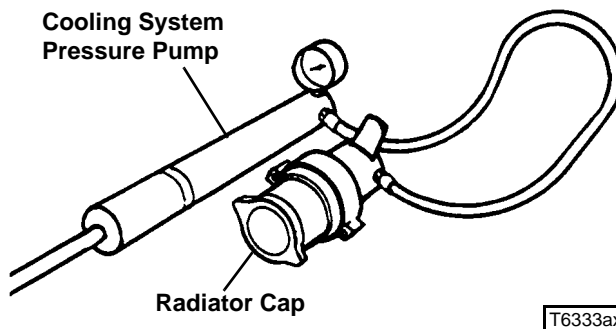

Specifications:

Radiator Cap Pressure
Valve Opening Pressure . . 83—97 kPa (12—14 psi)
Minimum pressure 76 kPa (11 psi)

Results:

- If cap leaks, retighten and test again. Replace cap if pressure is not within specification.



Suggest:

If the above button click is invalid.

Please download this document

first, and then click the above link

to download the complete manual.

Thank you so much for reading

THERMOSTAT OPENING TEST

Reason:

To determine opening temperature of thermostat.

Equipment:

- Thermometer
- Glass Container
- Heating Unit

Procedure:

⚠ CAUTION

DO NOT allow thermostat or thermometer to rest against the side or bottom of glass container when heating water. Either may rupture if overheated.

1. Suspend thermostat and a thermometer in a container of water.
2. Heat and stir the water. Observe opening action of thermometer and compare temperatures with specifications.
3. Remove thermostat and observe its closing action as it cools.

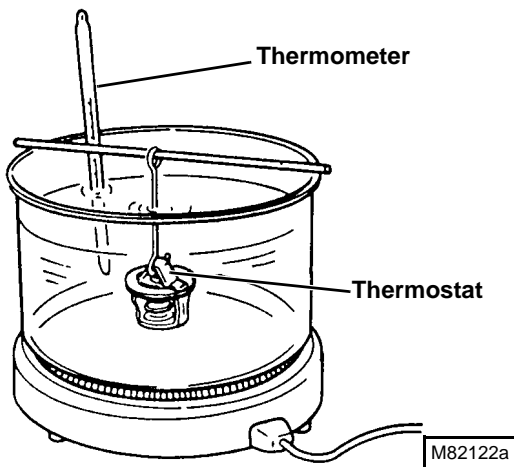

Specifications:

Begin Opening 71° C (160°F)
Fully Open 85° C (184°F)
Minimum Lift Height 8 mm (0.310 in.)

Results:

- If thermostat does not open according to specifications, replace.
- If closing action is not smooth and slow, replace thermostat.

COMPRESSION TEST

Reason:

To determine the condition of the pistons, rings, cylinder walls and valves.

Equipment:

- JT01682 Compression Gauge Assembly
- JDG472 Adapter

Procedure:

1. Run engine for 5 minutes to bring to operating temperature. Shut off engine.
2. Remove injection nozzles. (See FUEL INJECTION NOZZLES.)
3. Install JDG472 Adapter and JT01682 Compression Gauge Assembly in injector port.
4. Disconnect fuel shutoff solenoid connector.
5. Crank engine for 3 seconds with starter.
6. Record pressure reading for each cylinder.

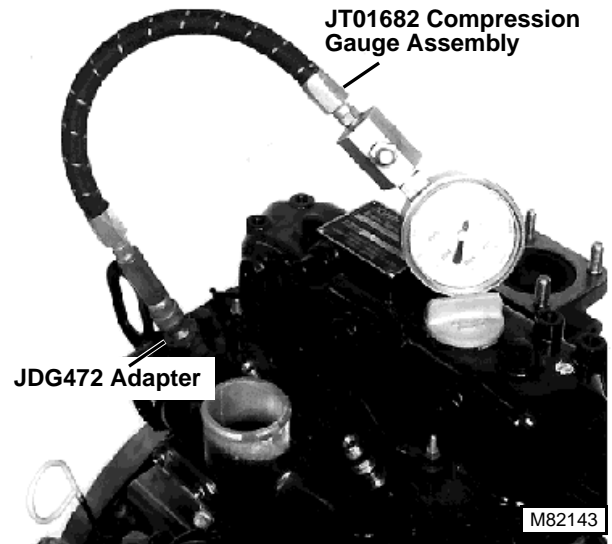

Specifications:

Compression Pressure 2448 kPa (355 psi)
Maximum Difference Between Cylinders 490 kPa (71 psi)
Minimum Cranking Speed 250 rpm

<https://www.ebooklibonline.com>

Hello dear friend!

Thank you very much for reading.

Enter the link into your browser.

The full manual is available for immediate download.

<https://www.ebooklibonline.com>