

314F, 518R, and 820R Walk-Behind Tillers

TECHNICAL MANUAL

**John Deere
Worldwide Commercial and
Consumer Equipment Division**

TM1687 (01Jan97)

Walk-Behind Tillers



Model 314F



Model 518R



Model 820R

This technical manual is written for an experienced technician and contains sections that are specifically for this product. It is a part of a total product support program.

The manual is organized so that all the information on a particular system is kept together. The order of grouping is as follows:

- Table of Contents
- General Diagnostic Information
- Specifications
- Electrical Wiring Harness Legend
- Component Location
- System Schematic
- Wiring Harness
- Troubleshooting Chart
- Theory of Operation
- Diagnostics
- Tests & Adjustments
- Repair

Note: Depending on the particular section or system being covered, not all of the above groups may be used.

Each section will be identified with a symbol rather than a number. The pages within a section will be consecutively numbered.

Headings in each section indicate the job being performed. A heading with no model designation applies to all the models in this manual. Headings followed by model designations apply only to those models.

All information, illustrations and specifications in this manual are based on the latest information available at the time of publication. The right is reserved to make changes at any time without notice.

We appreciate your input on this manual. To help, there are postage paid post cards included at the back. If you find any errors or want to comment on the layout of the manual please fill out one of the cards and mail it back to us.

COPYRIGHT© 1997
John Deere Worldwide Commercial and
Consumer Equipment Division
Horicon, WI
All rights reserved

Safety 

Specifications and Information 

Engine 

Electrical 

Power Train 

Miscellaneous 

<https://www.ebooklibonline.com>

Hello dear friend!

Thank you very much for reading.

Enter the link into your browser.

The full manual is available for immediate download.

<https://www.ebooklibonline.com>



RECOGNIZE SAFETY INFORMATION



This is the safety-alert symbol. When you see this symbol on your machine or in this manual, be alert to the potential for personal injury.

Follow recommended precautions and safe servicing practices.

- **UNDERSTAND SIGNAL WORDS**

A signal word—DANGER, WARNING, or CAUTION—is used with the safety-alert symbol.

- DANGER identifies the most serious hazards. Danger or Warning safety signs are located near specific hazards.
- CAUTION safety signs are used where general precautions should be used. CAUTION also calls attention to safety messages in this manual.

REPLACE SAFETY SIGNS

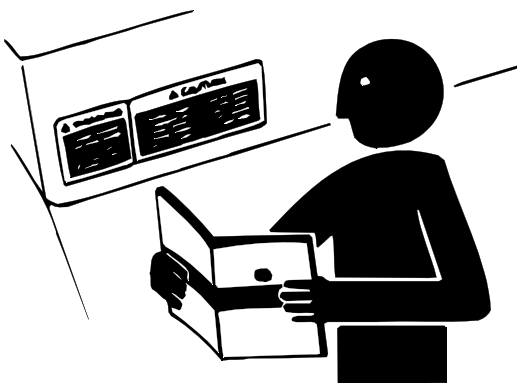

Replace missing or damaged safety signs. See the machine operator's manual for correct safety sign placement.

HANDLE FLUIDS SAFELY-AVOID FIRES

- **BE PREPARED FOR EMERGENCIES**

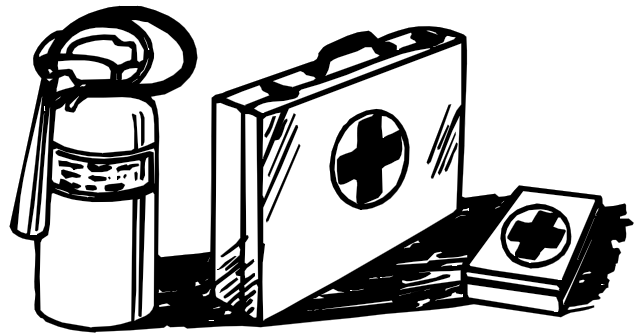

When you work around fuel, do not smoke or work near heaters or other fire hazards.

Store flammable fluids away from fire hazards. Do not incinerate or puncture pressurized containers.

Make sure machine is clean of trash, grease, and debris.

Do not store oily rags; they can ignite and burn spontaneously.

Be prepared if a fire starts.

Keep a first aid kit and fire extinguisher handy.

Keep emergency numbers for doctors, ambulance service, hospital, and fire department near your telephone.

USE SAFE SERVICE PROCEDURES

• WEAR PROTECTIVE CLOTHING

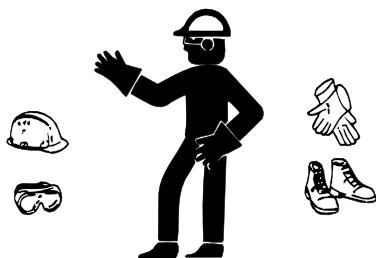

Wear close fitting clothing and safety equipment appropriate to the job.

Prolonged exposure to loud noise can cause impairment or loss of hearing. Wear a suitable hearing protective device such as earmuffs or earplugs to protect against objectionable or uncomfortable loud noises.

Operating equipment safely requires the full attention of the operator. Do not wear radio or music headphones while operating machine.

• SERVICE MACHINES SAFELY

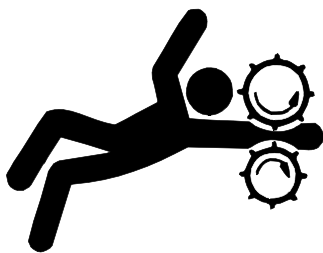

Tie long hair behind your head. Do not wear a necktie, scarf, loose clothing, or necklace when you work near machine tools or moving parts. If these items were to get caught, severe injury could result.

Remove rings and other jewelry to prevent electrical shorts and entanglement in moving parts.

• USE PROPER TOOLS

Use tools appropriate to the work. Makeshift tools and procedures can create safety hazards. Use power tools only to loosen threaded parts and fasteners. For loosening and tightening hardware, use the correct size tools. **DO NOT** use U.S. measurement tools on metric fasteners. Avoid bodily injury caused by slipping wrenches. Use only service parts meeting John Deere specifications.

• PARK MACHINE SAFELY

Before working on the machine:

1. Be sure all equipment is resting firmly on the ground.
2. Stop the engine.
3. Disconnect the spark plug.
4. Hang a "DO NOT OPERATE" tag in operator station.

• SUPPORT MACHINE PROPERLY AND USE PROPER LIFTING EQUIPMENT

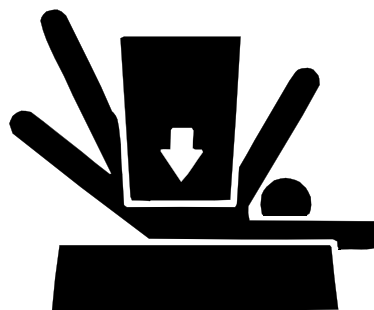

If you must work on a lifted machine or attachment, securely support the machine or attachment.

Do not support the machine on cinder blocks, hollow tiles, or props that may crumble under continuous load. Do not work under a machine that is supported solely by a jack. Follow recommended procedures in this manual.

Lifting heavy components incorrectly can cause severe injury or machine damage. Follow recommended procedure for removal and installation of components in the manual.

• WORK IN A CLEAN AREA

Before starting a job:

1. Clean work area and machine.
2. Make sure you have all necessary tools to do your job.
3. Have the right parts on hand.
4. Read all instructions thoroughly; do not attempt shortcuts.

• USING HIGH PRESSURE WASHERS

Directing pressurized water at electronic/electrical components or connectors, bearings, hydraulic seals, fuel injection pumps or other sensitive parts and components may cause product malfunctions. Reduce pressure and spray at a 45 to 90 degree angle.





- **Illuminate Work Area Safely**

Illuminate your work area adequately but safely. Use a portable safety light for working inside or under the machine. Make sure the bulb is enclosed by a wire cage. The hot filament of an accidentally broken bulb can ignite spilled fuel or oil.

- **Work In Ventilated Area**

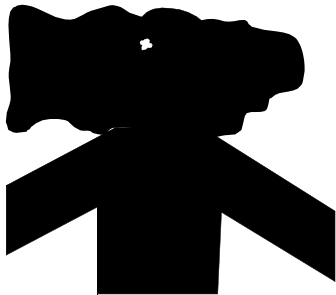

Engine exhaust fumes can cause sickness or death. If it is necessary to run an engine in an enclosed area, remove the exhaust fumes from the area with an exhaust pipe extension.

If you do not have an exhaust pipe extension, open the doors and get outside air into the area.

WARNING: California Proposition 65

Gasoline engine exhaust from this product contains chemicals known to the State of California to cause cancer, birth defects, or other reproductive harm.

- **Remove Paint Before Welding Or Heating**

Avoid potentially toxic fumes and dust. Hazardous fumes can be generated when paint is heated by welding, soldering, or using a torch. Do all work outside or in a well ventilated area. Dispose of paint and solvent properly. Remove paint before welding or heating: If you sand or grind paint, avoid breathing the dust. Wear an approved respirator. If you use solvent or paint stripper, remove stripper with soap and water before welding. Remove solvent or paint stripper containers and other flammable material from area. Allow fumes to disperse at least 15 minutes before welding or heating.

- **Avoid Harmful Asbestos Dust**

Avoid breathing dust that may be generated when handling components containing asbestos fibers. Inhaled asbestos fibers may cause lung cancer.

Components in products that may contain asbestos fibers are brake pads, brake band and lining assemblies, clutch plates, and some gaskets. The asbestos used in these components is usually found in a resin or sealed in some way. Normal handling is not hazardous as long as airborne dust containing asbestos is not generated.

Avoid creating dust. Never use compressed air for cleaning. Avoid brushing or grinding material containing asbestos. When servicing, wear an approved respirator. A special vacuum cleaner is recommended to clean asbestos. If not available, apply a mist of oil or water on the material containing asbestos. Keep bystanders away from the area.

SERVICE TIRES SAFELY

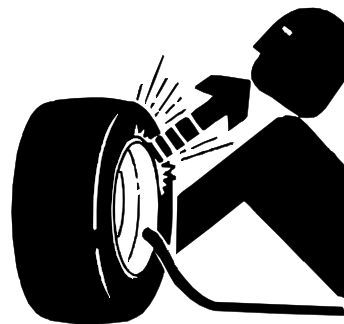

Explosive separation of a tire and rim parts can cause serious injury or death.

Do not attempt to mount a tire unless you have the proper equipment and experience to perform the job. Always maintain the correct tire pressure. Do not inflate the tires above the recommended pressure. Never weld or heat a wheel and tire assembly. The heat can cause an increase in air pressure resulting in a tire explosion. Welding can structurally weaken or deform the wheel.

When inflating tires, use a clip-on chuck and extension hose long enough to allow you to stand to one side and NOT in front of or over the tire assembly. Use a safety cage if available.

Check wheels for low pressure, cuts, bubbles, damaged rims or missing lug bolts and nuts.

AVOID INJURY FROM ROTATING TINES

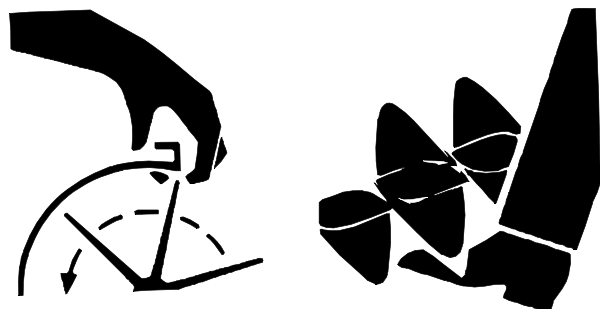

Keep hands and feet away while machine is running. Shut off engine before starting service. Do not defeat safety systems to allow machine to operate unattended.

HANDLE CHEMICAL PRODUCTS SAFELY

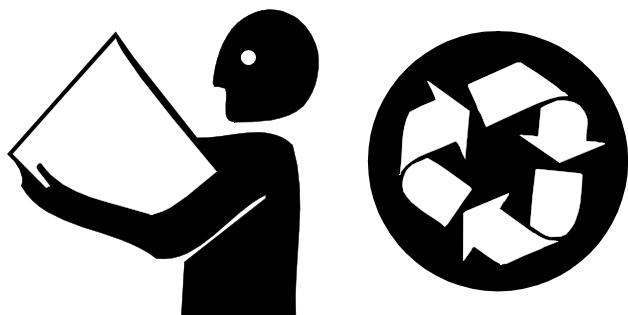

Direct exposure to hazardous chemicals can cause serious injury. Potentially hazardous chemicals used with John Deere equipment include such items as lubricants, coolants, paints, and adhesives.

A Material Safety Data Sheet (MSDS) provides specific details on chemical products: physical and health hazards, safety procedures, and emergency response techniques. Check the MSDS before you start any job using a hazardous chemical. That way you will know exactly what the risks are and how to do the job safely. Then follow procedures and recommended equipment.

• Dispose of Waste Properly

Improperly disposing of waste can threaten the environment and ecology. Potentially harmful waste used with John Deere equipment include such items as oil, fuel, coolant, brake fluid, filters, and batteries. Use leakproof containers when draining fluids. Do not use food or beverage containers that may mislead someone into drinking from them. Do not pour waste onto the ground, down a drain, or into any water source. Inquire on the proper way to recycle or dispose of waste from your local environmental or recycling center, or from your John Deere dealer.

LIVE WITH SAFETY



Before returning machine to customer, make sure machine is functioning properly, especially the safety systems. Install all guards and shields.

CONTENTS

Page



SPECIFICATIONS

TORQUE VALUES	2
METRIC FASTENER TORQUE VALUES	2
INCH FASTENER TORQUE VALUES	3
GASOLINE	4
GASOLINE— NORTH AMERICA	4
GASOLINE STORAGE— NORTH AMERICA	4
GASOLINE—EUROPE	5
GASOLINE STORAGE—EUROPE	5
LUBRICATION	6
ENGINE OIL—NORTH AMERICA	6
ENGINE OIL—EUROPE	6
ENGINE BREAK-IN OIL— NORTH AMERICA	7
ENGINE BREAK-IN OIL— EUROPE	8
ANTI-CORROSION GREASE	9
ALTERNATIVE LUBRICANTS	9
SYNTHETIC LUBRICANTS	9
LUBRICANT STORAGE	9
MIXING OF LUBRICANTS	9
GREASE —NORTH AMERICA	10
GREASE —EUROPE	10
GEAR CASE AND TRANSMISSION GREASE—NORTH AMERICA	11
GEAR CASE AND TRANSMISSION GREASE—EUROPE	11
PRODUCT IDENTIFICATION LOCATIONS	12

SPECIFICATIONS

ENGINE SPECIFICATIONS



	314F	518R	820R
Manufacturer	Tecumseh	Briggs & Stratton	Briggs & Stratton
Model	H30	135292	196432
Type (cycle)	Air cooled (4)	Air cooled (4)	Air cooled (4)
Horsepower@ RPM	3 hp (2.23 kW)@ 3600 RPM	5 hp (3.72 kW)@ 3250 RPM	8 hp (5.9 kW)@ 3250 RPM
Displacement	148.5 cc (9.06 cu. in.)	206 cc (12.57 cu. in.)	319 cc (19.44 cu. in.)
Slow Idle Speed	2150±150 RPM	1750 RPM	1750 RPM
Fast Idle Speed	3600±150 RPM	3300±100 RPM	3300±100 RPM
Cylinder Bore (Nominal)	63.5 mm (2.5 in.)	65.1 mm (2.562 in.)	76.187 mm (2.9995 in.)
Stroke	46.74 mm (1.844 in.)	61.98 mm (2.44 in.)	69.85 mm (2.75 in.)
Lubrication Type	Splash System	Splash System	Splash System
Oil capacity	0.62L (21 U.S. oz.)	0.591 L (20 U.S. oz.)	1.30 L (44 U.S. oz.)
Oil fill	Right side of Crankcase cover	Either side of Crankcase cover	Extended oil fill and dipstick.

FUEL

Type required	Unleaded Gasoline, 87 Octane		
Fuel tank capacity	1.9 L (2 U.S. qt.)	2.84 L (3 U.S. qt.)	3.79 L (1 U.S. gal.)
Carburetor	Float-type with primer	Diaphragm type	Float type
Fuel filter	Screen in fuel tank	Screen on fuel pickup Screen on main jet pickup	Screen in fuel tank

ELECTRICAL SPECIFICATIONS

Item	314F	518R	820R
Ignition	Electronic	Electronic	Electronic
Spark plug	Resistor (J17LM Champion)	Resistor (RJ19LM Champion)	Resistor (RJ19LM Champion)
Starting	Recoil with compression release standard on all models.		

Electric start			Optional 120 VAC
Armature Air Gap	.3175 mm (0.0125 in.)	0.25-0.36 mm 0.010-0.014	0.25-0.36 mm 0.010-0.014
Spark Plug Gap	0.762 mm (0.030 in.)	0.71-0.084 mm (0.028-0.033 in.)	0.71-0.084 mm (0.028-0.033 in.)

REPAIR SPECIFICATIONS

Item	314F	518R	820R
Carburetor Float	Float gauge or 5.56 mm (7/32 in.) drill bit	Diaphragm type	Non Adjustable
Connecting Rod:			
Crankpin End Maximum I.D.	21.89-21.91 mm (0.8620-0.8625 in.)	25.43 mm (1.001 in.)	28.63 mm (1.127 in.)
Crankpin End Standard I.D.	21.89-21.91 mm (0.8620-0.8625 in.)	25.395-25.410 mm (0.9998-1.0004 in.)	28.547-28.557 mm (1.1239-1.1243 in.)
Piston Pin Bore Maximum I.D.	14.318 mm (0.5637 in.)	12.50 mm (0.492 in.)	17.12 mm (0.674 in.)
Piston Pin Bore Standard I.D.	14.305-14.318 mm (0.5632-0.5637 in.)	12.451-12.466 mm (0.4902-0.4908 in.)	17.087-17.094 mm (0.6727-0.6730 in.)
Crankshaft Journals:			
Flywheel End Minimum O.D.	25.36-25.37 mm (0.9985-0.9990 in.)	22.17 mm (.873 in.)	29.95 mm (1.179 in.)
Flywheel End Standard O.D.	25.36-25.37 mm (0.9985-0.9990 in.)	22.205-22.225 mm (.8742-.8750 in.)	29.987-30.008 mm (1.1806-1.1814 in.)
PTO End Minimum O.D.	22.18-22.19 mm (0.8735-0.8740 in.)	25.35 mm (0.998 in.)	29.95 mm (1.179 in.)
PTO End Standard O.D.	22.18-22.19 mm (0.8735-0.8740 in.)	25.380-25.400 mm (0.9992-1.0000 in.)	29.987-30.008 mm (1.1806-1.1814 in.)
Crankshaft Crankpin Minimum O.D.	21.87-21.88 mm (0.8610-0.8615 in.)	25.30 mm (0.996 in.)	28.50 mm (1.122 in.)
Crankshaft Crankpin Standard O.D.	21.87-21.88 mm (0.8610-0.8615 in.)	25.349-25.370 mm (0.9980-.9988 in.)	28.547-28.557 mm (1.1239-1.1243 in.)
Crankshaft End Play	0.13-0.69 mm (0.005-0.027 in.)	0.05-0.30 mm (0.002-0.012 in.)	0.051-0.762 mm (0.002-0.030 in.)
Camshaft Journals:			
PTO End Maximum O.D.	12.64-12.65 mm (.4975-.4980 in.)	12.65 mm (0.498 in.)	12.65 mm (0.498 in.)
PTO End	12.64-12.65 mm	12.67-12.70 mm	12.67-12.70 mm



Standard O.D.	(.4975-.4980 in.)	0.499-0.500 in.	0.499-0.500 in.
Flywheel End	12.64-12.65 mm	12.65 mm	12.65 mm
Maximum O.D.	(.4975-.4980 in.)	(0.498 in.)	(0.498 in.)
Flywheel End	12.64-12.65 mm	12.67-12.70 mm	12.67-12.70 mm
Standard O.D.	(.4975-.4980 in.)	(0.499-0.500 in.)	(0.499-0.500 in.)

Camshaft Lobe O.D.:

Intake (Standard)	Not Available	24.46-24.71 mm (0.963-0.973 in.)	24.46-24.71 mm (0.963-0.973 in.)
Intake (Maximum)	Not Available	24.13 mm (0.950 in.)	24.13 mm (0.950 in.)
Exhaust (Standard)	Not Available	24.46-24.71 mm (0.963-0.973 in.)	25.36-25.44 mm (0.9985-1.0015 in.)
Exhaust (Maximum)	Not Available	24.13 mm (0.950 in.)	24.82 mm (0.977 in.)

Camshaft Bearing (In Crankcase & Crankcase Cover):

Flywheel End	12.64-12.65 mm	12.80 mm	12.80 mm
Maximum I.D.	(0.4975-0.4980 in.)	(0.504 in.)	(0.504 in.)
Flywheel End	12.64-12.65 mm	12.71-12.74 mm	12.71-12.74 mm
Standard I.D.	(0.4975-0.4980 in.)	(0.5005-.05015 in.)	(0.5005-0.5015 in.)
P.T.O. End	12.64-12.65 mm	12.80 mm	12.80 mm
Maximum I.D.	(0.4975-0.4980 in.)	(0.504 in.)	(0.504 in.)
P.T.O. End	12.64-12.65 mm	12.73-12.75 mm	12.73 mm
Standard I.D.	(0.4975-0.4980 in.)	(0.501-0.502 in.)	(0.501-0.502 in.)

Crankshaft Bearings (In Crankcase & Crankcase Cover):

P.T.O. End	22.24-22.25 mm	25.48 mm	30.10 mm
Maximum I.D.	(0.8755-0.8760 in.)	(1.003 in.)	(1.185 in.)
P.T.O. End	22.24-22.25 mm	25.433-25.446 mm	30.043-30.088 mm
Standard I.D.	(0.8755-0.8760 in.)	(1.0013-1.0018 in.)	(1.1828-1.1846 in.)
Flywheel End	25.41-25.43 mm	22.30 mm	30.10 mm
Maximum I.D.	(1.0005-1.0010 in.)	(0.878 in.)	(1.185 in.)
Flywheel End	25.41-25.43 mm	22.271-22.281 mm	30.043-30.088 mm
Standard I.D.	(1.0005-1.0010 in.)	(0.8768-0.8772 in.)	(1.1828-1.1846 in.)

Cylinder Bore:

Bore I.D. (Min.-Max.)	63.5-63.53 mm (2.5000-2.5010 in.)	65.062-65.088 mm (2.5615-2.5625 in.)	76.175-76.200 mm (2.999-3.000 in.)
Bore I.D. (Nominal)	63.5 mm (2.50 in.)	65.1 mm (2.562 in.)	76.187 mm (2.9995 in.)

Piston Pin:

Piston Bore (Maximum)	0.13 mm (0.005 in.)	12.47 mm (0.491 in.)	17.09 mm (0.673 in.)
Piston Bore (Standard)	0.13 mm (0.005 in.)	12.45-12.47 mm (0.490-0.491 in.)	17.081-17.087 mm (0.6725-0.6727 in.)
Connecting Rod Bore (Maximum)	0.13 mm (0.005 in.)	12.50 mm (0.492 in.)	17.12 mm (0.674 in.)
Connecting Rod Bore (Standard)	0.13 mm (0.005 in.)	12.451-12.466 mm (0.4902-0.4908 in.)	17.087-17.094 mm (0.6727-0.6730 in.)
Pin Diameter (Minimum)	14.295 mm (0.5628 in.)	12.42 mm (0.489 in.)	17.04 mm (0.671 in.)
Pin Diameter (Standard)	14.295-14.300 mm (0.5628-0.5630 in.)	12.441-12.446 mm (0.4898-0.4900 in.)	17.074-17.082 mm (0.6722-0.6725 in.)
Cylinder Bore Cross Hatch Pattern	45 degrees	45 degrees	45 degrees
Cylinder Head Distortion (Max.)	0.05 mm (0.002 in.)	Not available at time of printing	Not available at time of printing

**Valve Clearance:**

Intake	0.10-0.25 mm (0.004-0.010 in.)	0.10-0.20 mm (0.004-0.008 in.)	0.13-0.18 mm (0.005-0.007 in.)
Exhaust	0.10-0.25 mm (0.004-0.010 in.)	0.15-0.30 mm (0.006-0.012 in.)	0.23-0.28 mm (0.009-0.011 in.)

Valves:

Head Margins (Intake)	0.7874 mm (0.0310 in.)	1.04 mm (0.041 in.)	0.683 mm (0.0269 in.)
Head Margin (Exhaust)	0.7874 mm (0.0310 in.)	1.04 mm (0.041 in.)	0.826 mm (0.0625 in.)
Exhaust Face Angle	46°	44.75°	44.75°
Intake Face Angle	46°	29.75°	29.75°
Intake Stem O.D.	6.31-6.32 mm (0.248-0.249 in.)	6.261-6.2287 mm (0.2465-0.2475 in.)	7.848-7.874 mm (0.309-0.310 in.)
Exhaust Stem O.D.	6.18-6.20 mm (0.243-0.244 in.)	6.261-6.2287 mm (0.2465-0.2475 in.)	7.848-7.874 mm (0.309-0.310 in.)

Valve Seats:

Exhaust Angle	46°	45.25°	45.25°
Intake Angle	46°	30.25°	30.25°
Minimum Width	0.889-1.143 mm (0.035-0.045 in.)	0.79 mm (0.031 in.)	0.79 mm (0.031 in.)

Valve Guides:

Exhaust I.D.	7.130 mm (0.2807 in.)	6.388-6.414 mm (0.2515-0.2525 in.)	7.938-7.963 mm (0.3125-0.3135 in.)
Intake I.D.	7.130 mm (0.2807 in.)	6.325-6.350 mm (0.2490-0.2500 in.)	7.912-7.938 mm (0.3115-0.3125 in.)

Piston Rings:

Ring-to-Land Clearance:

Maximum Clearance	0.127 mm (0.005 in.)	0.18 mm (0.007 in.)	0.23 mm (0.009 in.)
Top Ring (Standard)	0.05-0.127 mm (0.002-0.005 in.)	0.089-0.152 mm (0.0035-0.006 in.)	0.10-0.15 mm (0.004-0.006 in.)
Center Ring (Standard)	0.05-0.127 mm (0.002-0.005 in.)	0.015-0.660 mm (0.0006-0.0026 in.)	0.038-0.089 mm (0.0015-0.0035 in.)
Oil Control Ring (Standard)	0.013-0.089 mm (0.0005-0.0035 in.)	Not Available Not Available	Not Available Not Available

Piston Ring End Gap:

Compression Max.	0.432 mm (0.017 in.)	0.889 mm (0.035 in.)	0.76 mm (0.030 in.)
Top (Standard)	0.18-0.43 mm (.007-.017 in.)	0.13-0.33 mm (.005-.013 in.)	0.25-0.46 mm (.010-.018 in.)
Center (Standard)	0.18-0.43 mm (.007-.017 in.)	0.36-0.56 mm (0.014-0.022 in.)	0.25-0.46 mm (.010-.018 in.)
Oil Control Max.	Not Available	1.14 mm (0.045 in.)	0.89 mm (0.035 in.)
Oil Control (Std.)	0.432 mm (0.017 in.)	0.33-0.53 mm (0.013-0.021 in.)	0.25-0.46 mm (.010-.018 in.)

TORQUE SPECIFICATIONS

	314F	518R	820R
Spark Plug	29 N•m (250 lb-in.)	20 N•m (180 lb-in.)	20 N•m (180 lb-in.)
Cylinder Head Cap Screw	22.5 N•m (200 lb-in.)	15.7 N•m (140 lb-in.)	16.9 N•m (150 lb-in.)
Flywheel Nut	47.5 N•m (35 lb-ft)	81 N•m (60 lb-ft)	108 N•m (80 lb-ft)
Intake Manifold Cap Screw	10 N•m (90 lb-in.)	13.5 N•m (120 lb-in.)	13.5 N•m (120 lb-in.)
Muffler Cap Screw	4 N•m (37.5 lb-in.)	12 N•m (100 lb-in.)	10.2 N•m (90 lb-in.)
Carburetor Mount	7.5 N•m (68 lb-in.)	9 N•m (90 lb-in.)	9 N•m (90 lb-in.)
Connecting Rod Cap Screw	11.5 N•m (105 lb-in.)	11 N•m (100 lb-in.)	21 N•m (185 lb-in.)
Crankcase Cover Cap Screw	13 N•m (115 lb-in.)	11 N•m (100 lb-in.)	14 N•m (125 lb-in.)

OTHER MATERIALS

- SCOTCH-BRITE abrasive pads. Remove carbon deposits from combustion chamber
- John Deere NEVER-SEEZ® Lubricant PT569. Apply to crankshaft end.
- Thread Lock and Sealer (Medium Strength) T43512. Apply to governor shaft.
- LOCTITE® PRODUCTS thread locking compound
- TY9477 (#242) (Medium Strength) Apply to governor shaft.

® LOCTITE is a registered trademark of the Loctite Corp.

COMPONENT LOCATION—314F ENGINE

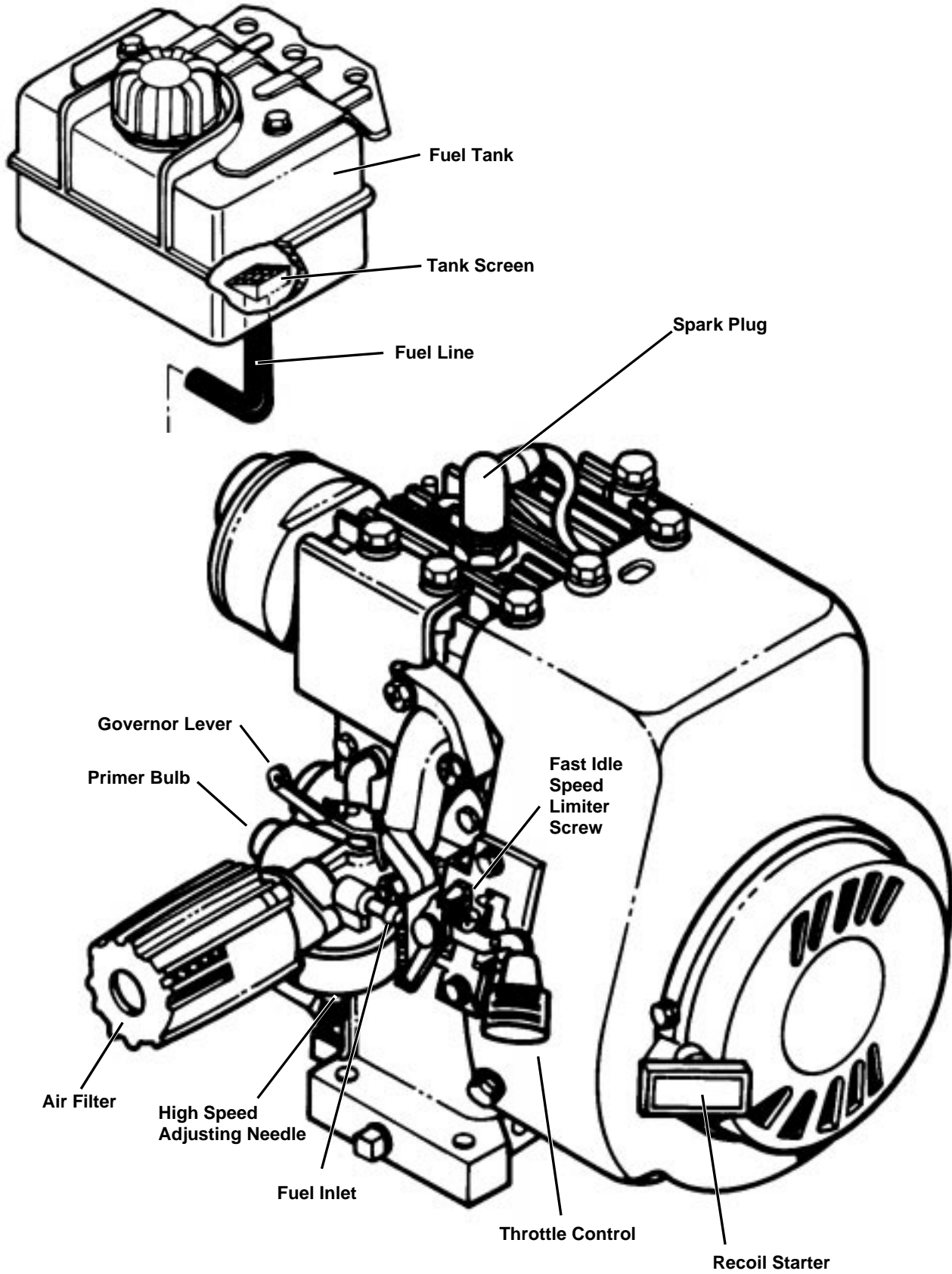

M87452A

COMPONENT LOCATION—518R ENGINE

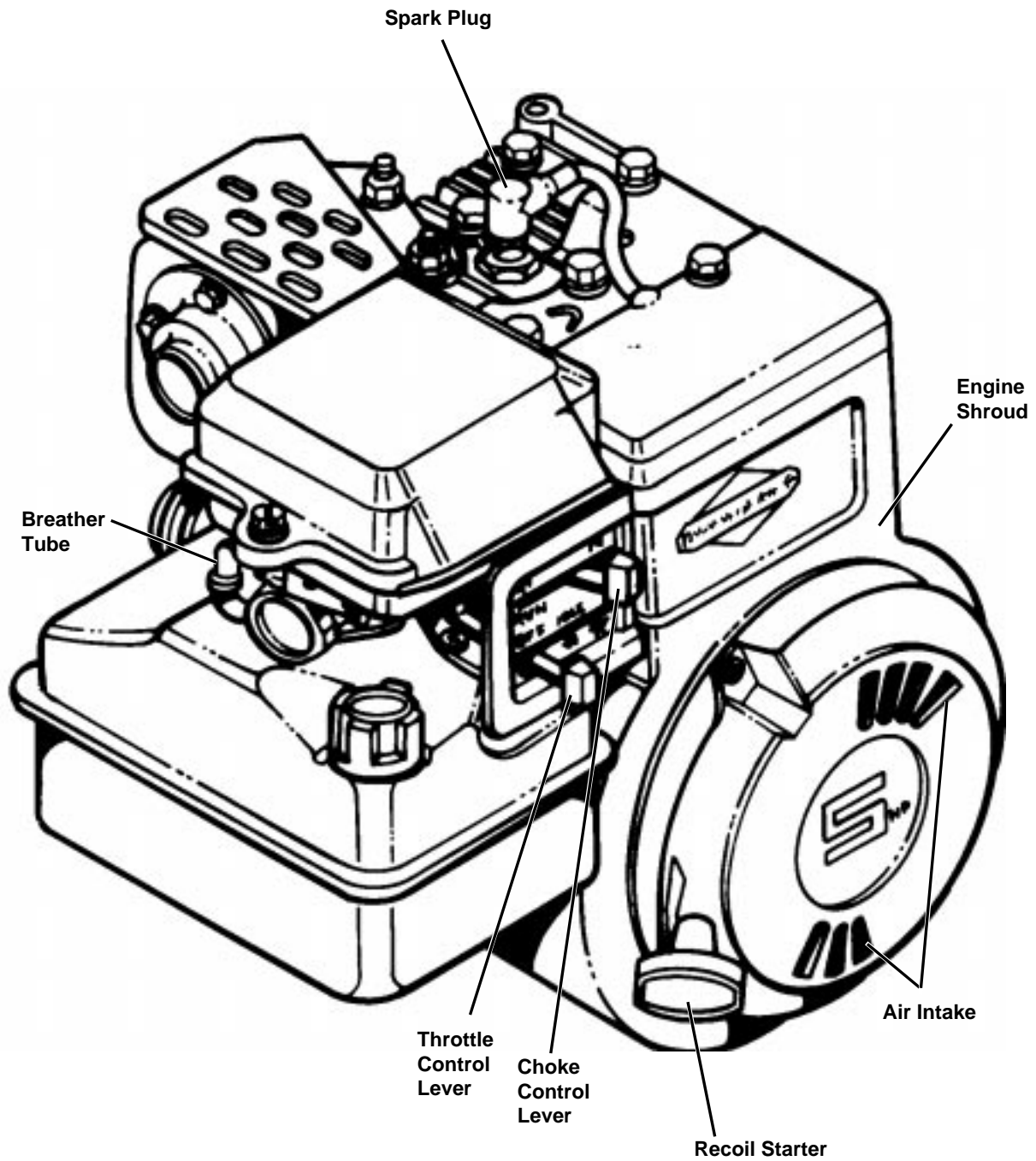

M87497

COMPONENT LOCATION—820R ENGINE

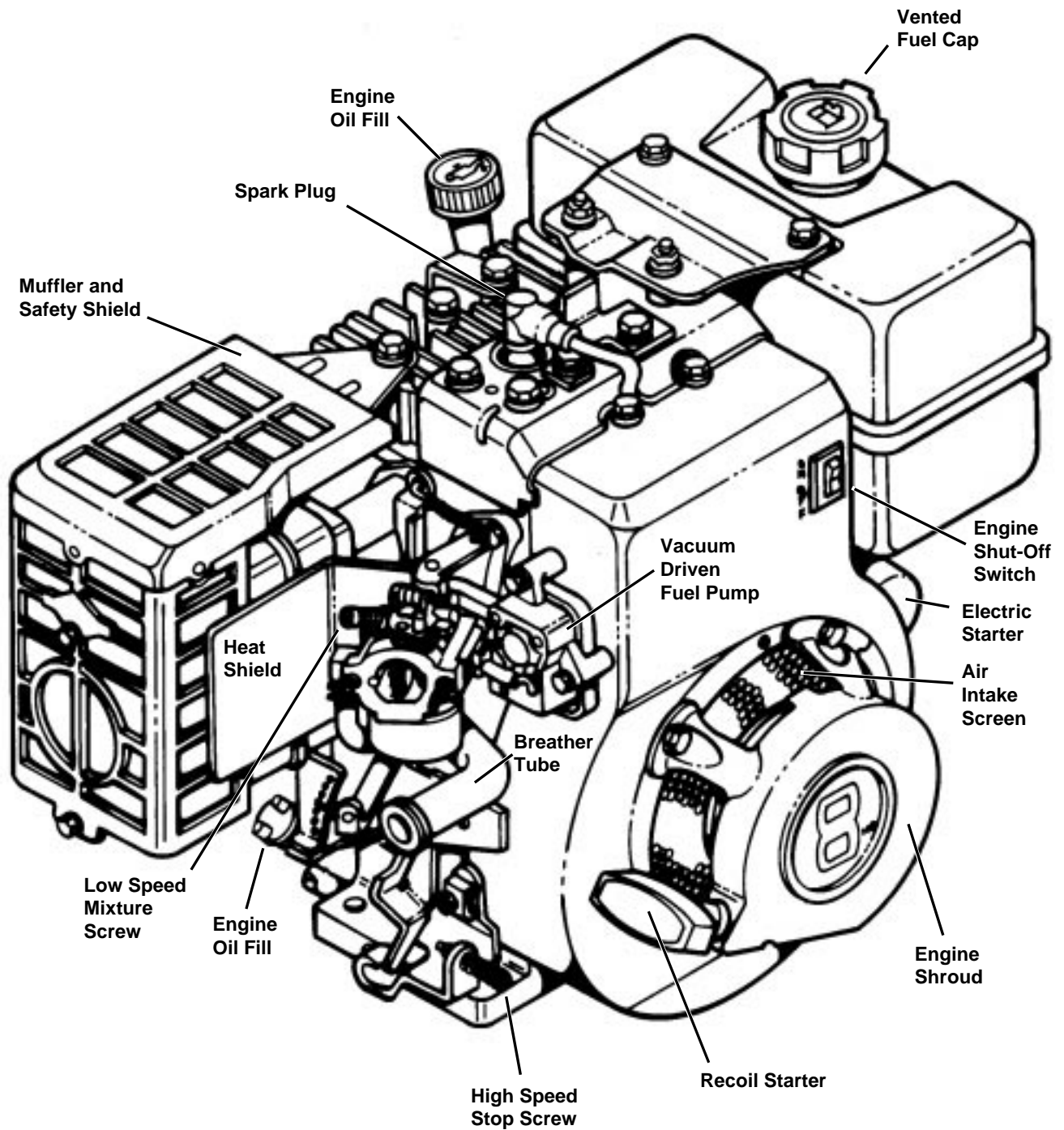

M87496

COMPONENT LOCATION—314F CARBURETOR

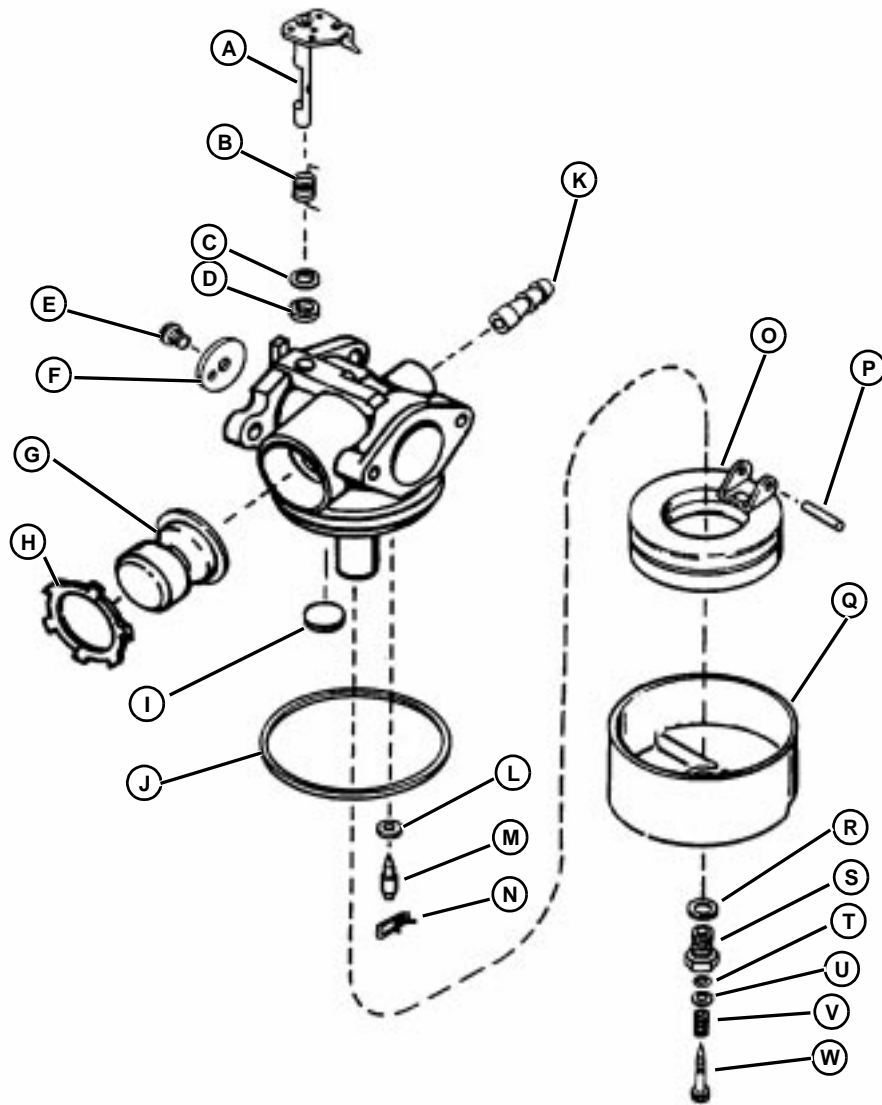

M87451

- A. Throttle Shaft
- B. Return Spring
- C. Dust Seal Washer
- D. Dust Seal, Throttle
- E. Screws
- F. Throttle Valve
- G. Primer Bulb
- H. Retainer
- I. Welch Plug

- J. O-Ring
- K. Fuel Inlet Fitting
- L. Inlet Seat
- M. Inlet Needle
- N. Clip
- O. Float
- P. Float Shaft
- Q. Float Bowl

- R. Gasket
- S. Float Bowl Retaining Nut
- T. O-Ring
- U. Washer
- V. Spring
- W. Fast Idle Adjustment Screw

COMPONENT LOCATION—518R CARBURETOR

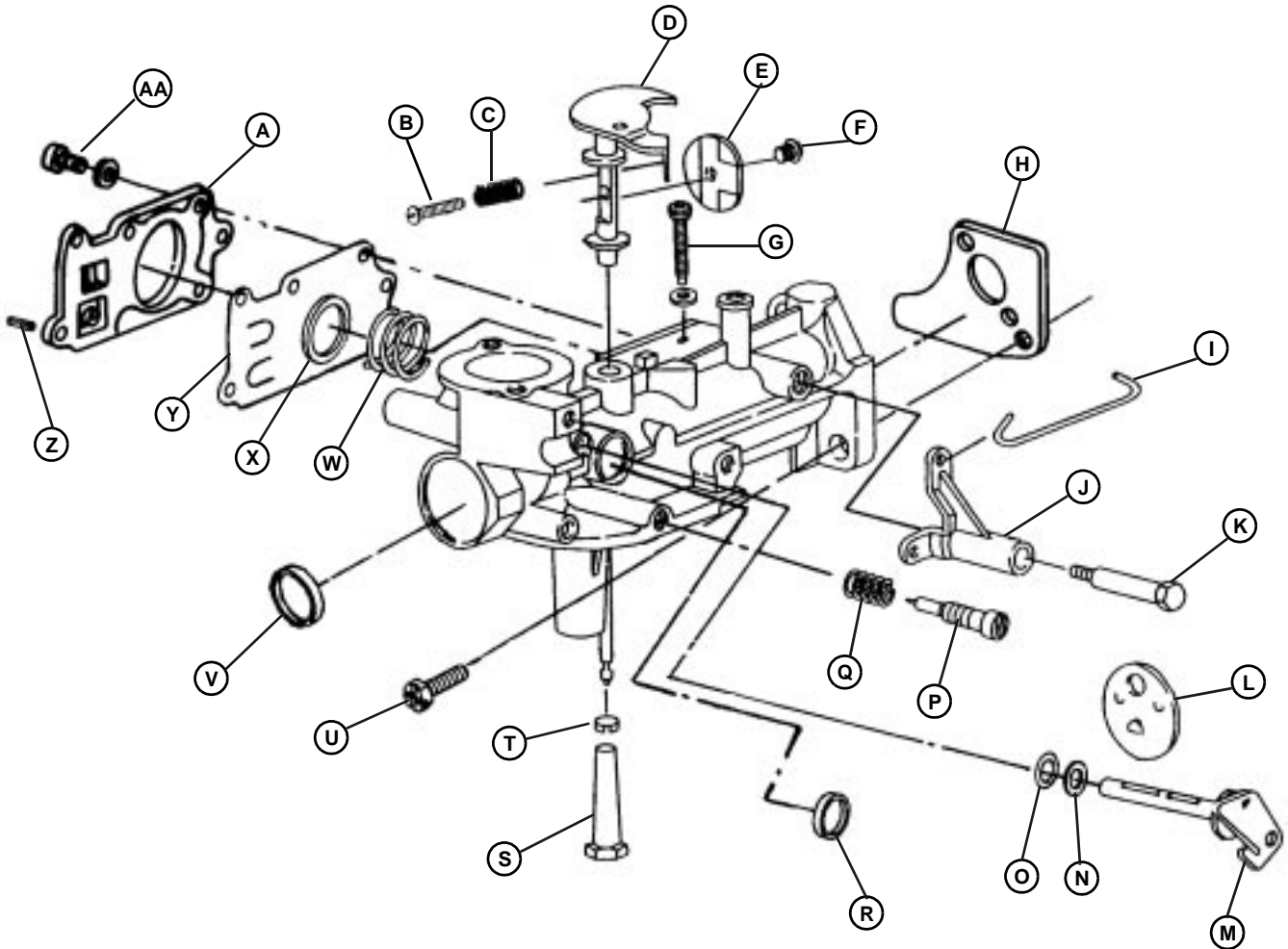

M87500

- A. Fuel Pump Cover
- B. Idle Speed Adjustment Screw
- C. Spring
- D. Throttle Shaft
- E. Throttle Plate
- F. Screw
- G. Fuel Tank Mounting Screw/
Lockwasher
- H. Gasket
- I. Throttle Link

- J. Pivot
- K. Shoulder Head Cap Screw
- L. Choke Plate
- M. Choke Shaft
- N. Washer
- O. Felt Washer
- P. Idle Mixture Screw
- Q. Spring
- R. Welch Plug
- S. Fuel Pickup

- T. Retaining Clip
- U. Carburetor Mounting Cap Screw
- V. Welch Plug
- W. Spring
- X. Spring Cap
- Y. Fuel Pump Diaphragm
- Z. Roll Pin
- AA. Fuel Pump Cover Cap Screw



Suggest:

If the above button click is invalid.

Please download this document

first, and then click the above link

to download the complete manual.

Thank you so much for reading

COMPONENT LOCATION—820R CARBURETOR

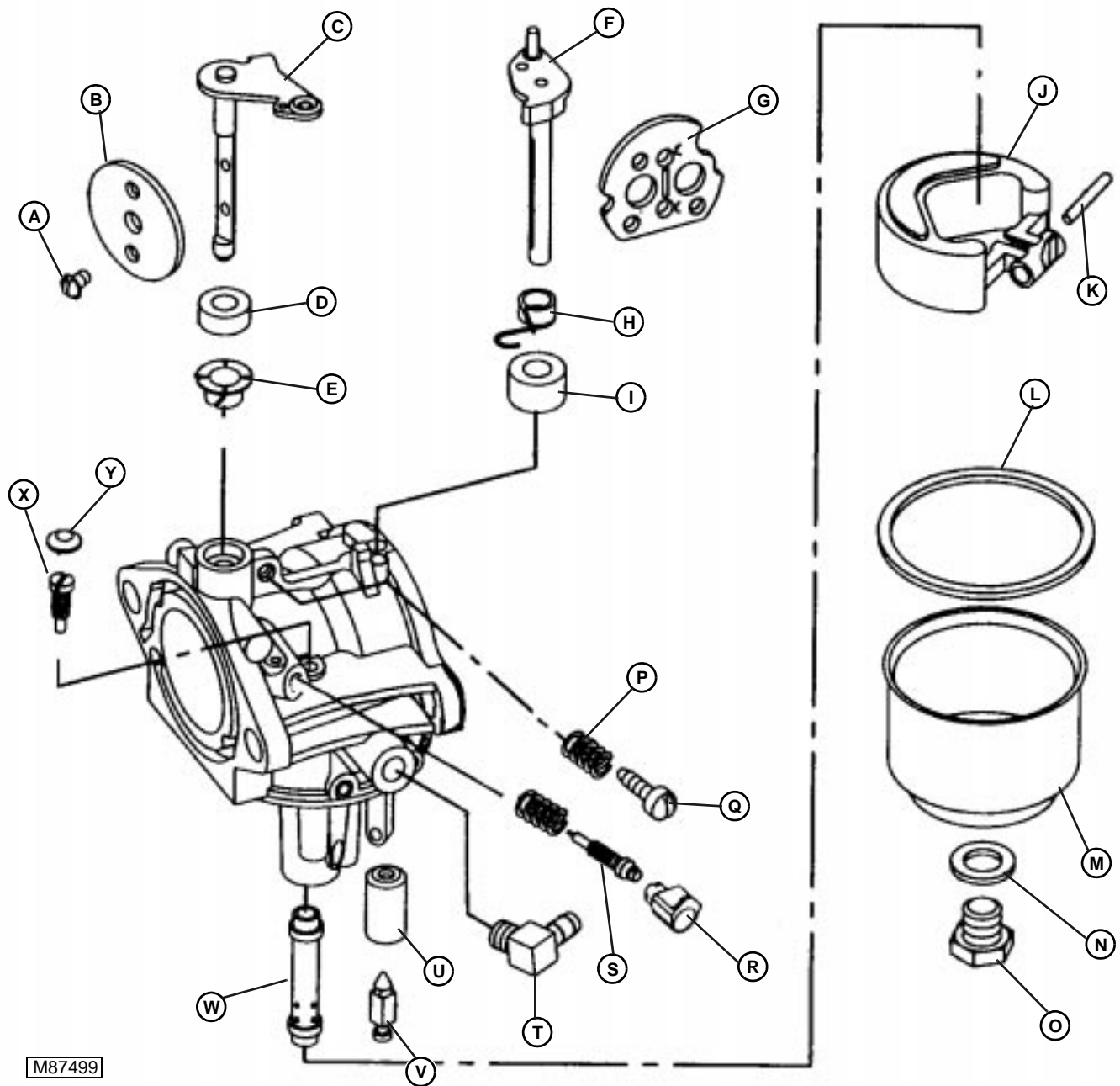

M87499

- A. Screw
- B. Throttle Plate
- C. Throttle Shaft
- D. Throttle Shaft Seal
- E. Bushing
- F. Choke Shaft
- G. Choke Plate
- H. Return Spring
- I. Choke Shaft Seal

- J. Float
- K. Float Shaft
- L. O-Ring
- M. Float Bowl
- N. Seal
- O. Bowl Retainer Bolt
- P. Spring
- Q. Idle speed Adjustment Screw
- R. Limiter Cap

- S. Low Speed Mixture Screw
- T. Fuel Inlet Fitting
- U. Inlet Valve Seat
- V. Inlet Valve
- W. Main Jet
- X. Pilot Jet
- Y. Welch Plug

<https://www.ebooklibonline.com>

Hello dear friend!

Thank you very much for reading.

Enter the link into your browser.

The full manual is available for immediate download.

<https://www.ebooklibonline.com>