

200 SYNCHRONOUS THINNER



JOHN DEERE

TECHNICAL MANUAL 200 SYNCHRONOUS THINNER

TM1113 (01SEP79) English

JOHN DEERE DES MOINES WORKS
TM1113 (01SEP79)

LITHO IN THE U.S.A.
ENGLISH

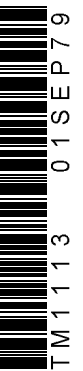

200 SYNCHRONOUS THINNER

Technical Manual TM-1113 (Sep-79)

CONTENTS

INTRODUCTION

SAFETY

SECTION 10 - General

GROUP 5 - Specifications

GROUP 10 - Lubrication

GROUP 15 - Diagnosing Malfunctions

SECTION 20 - ACTUATOR AND SOLENOID VALVE

GROUP 5 - Actuator

GROUP 10 - Solenoid Valve

GROUP 15 - Specifications, Torque Values, and Special Tools

SECTION 30 - HYDRAULIC SYSTEM

GROUP 5 - General Information, Diagnosis, and Tests

GROUP 10 - Hydraulic Motor

GROUP 15 - Accumulators

GROUP 20 - Hydraulic Hoses, Connections, and Valves

GROUP 25 - Specifications and Special Tools

SECTION 40 - ELECTRICAL SYSTEM

GROUP 5 - General Information, Diagnosis, and Tests

GROUP 10 - Alternator

GROUP 15 - Amplifier

GROUP 20 - Switch

GROUP 25 - Specifications and Special Tools

SECTION 50 - GAUGING SYSTEM

GROUP 5 - General Information and Diagnosing Malfunctions

GROUP 10 - Rig Hangers, Cone Guide Wheels, Guide Coulters, Gauge Wheels, and Adjustments

The specifications and design information contained in this manual were correct at the time this machine was manufactured. It is John Deere's policy to continually improve and update our machines. Therefore, the specifications and design information are subject to change without notice.

Right-Hand or Left-Hand Determination

"Right-hand" or "left-hand" sides are determined by facing the direction the thinner will travel when in use.

SI (International System) Units of Measure

U.S. units of measure are shown with their respective Metric equivalents throughout this technical manual. These equivalents are the SI (International System) Units of Measure.

FOR YOUR CONVENIENCE

Vertical lines appear in the margins of many of the pages. These lines identify new material and revised information that affects specifications, procedures, and other important instructions.

Copyright © 1978
DEERE & COMPANY
Moline, Illinois
All Rights Reserved

INTRODUCTION

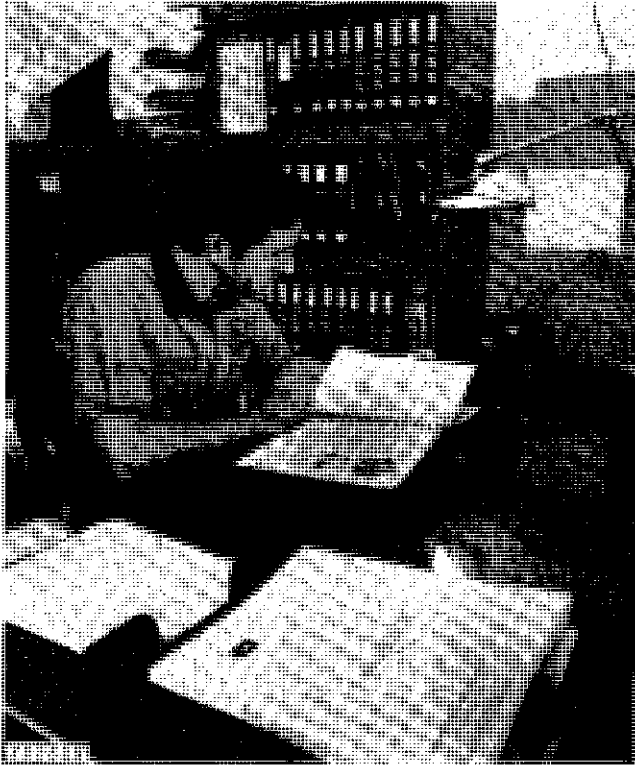

Use FOS Manuals for Reference

This technical manual is part of a twin concept of service:

- **FOS Manuals—for reference**
- **Technical Manuals—for actual service**

The two kinds of manuals work as a team to give you both the general background and technical details of shop service.

Fundamentals of Service (FOS) Manuals cover basic theory of operation, *fundamentals* of trouble shooting, *general* maintenance, and *basic* types of failures and their causes. FOS Manuals are for training new people and for reference by experienced technicians.

Technical Manuals are concise service guides for a *specific* machine. Technical Manuals are on-the-job guides containing only the vital information needed by an experienced technician.

NOTE: Whenever the service technician may need to refer to a FOS Manual for additional information, a specific manual number is given.

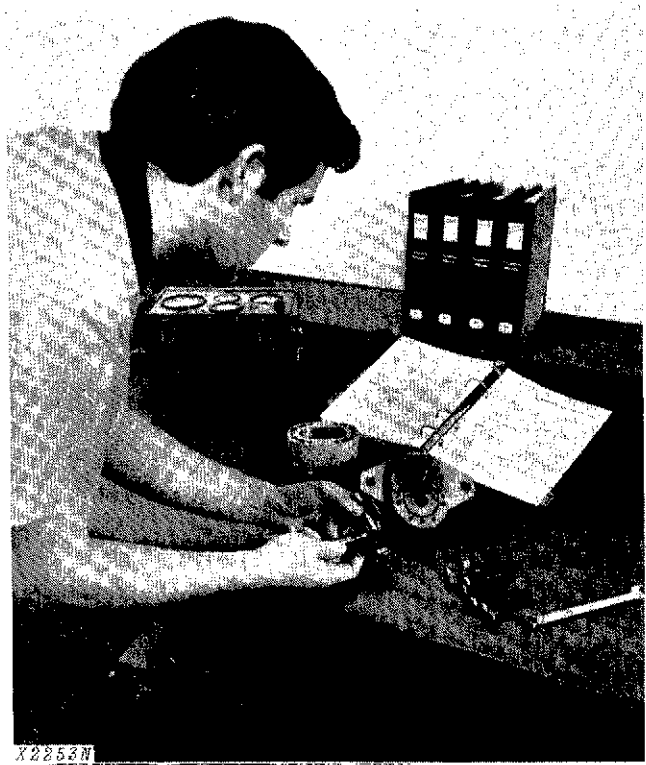

Use Technical Manuals for Actual Service

Some features of this technical manual:

- *Table of contents at front of manual*
- *Exploded views showing parts relationship*
- *Photos showing service techniques*
- *Specifications grouped for easy reference*

This technical manual was planned and written for you—a service technician. Keep it in a permanent binder in the shop where it is handy. Refer to it whenever in doubt about correct service procedures or specifications.

Using the technical manual as a guide will reduce error and costly delay. It will also assure you the best in finished service work.

FOR YOUR CONVENIENCE

Vertical lines appear in the margins of many of the pages. These lines identify new material and revised information that affects specifications, procedures, and other important instructions.

<https://www.ebooklibonline.com>

Hello dear friend!

Thank you very much for reading.

Enter the link into your browser.

The full manual is available for immediate download.

<https://www.ebooklibonline.com>

SAFETY AND YOU



T27999N

INTRODUCTION

 This safety alert symbol identifies important safety messages in this manual and on the machine. When you see this symbol, be alert to the possibility of personal injury and carefully read the message that follows.

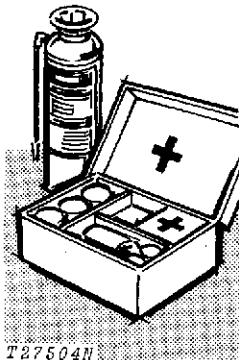

T27504N

Be prepared if an accident or fire should occur. Learn where the first aid kit and the fire extinguishers are located—know how to use them.

PERSONAL SAFETY

Shut off tractor engine and remove switch key before working on the thinner when it is attached to the tractor.

If it is necessary to make checks with the engine running, ALWAYS USE TWO PEOPLE—with the operator, at the controls, able to see the person doing the checking. Also, put the transmission in neutral, set the brake, and apply any safety locks provided. KEEP HANDS AWAY FROM MOVING PARTS.

Be Alert!

Plan ahead—work safely—avoid accidental damage and injury. If a careless moment does cause an accident or fire, react quickly with the tools and skills at hand. Know how to use a first aid kit and a fire extinguisher. Know where to get aid and assistance. In an emergency, split-second action is the key to safety.

Avoid Fire Hazards

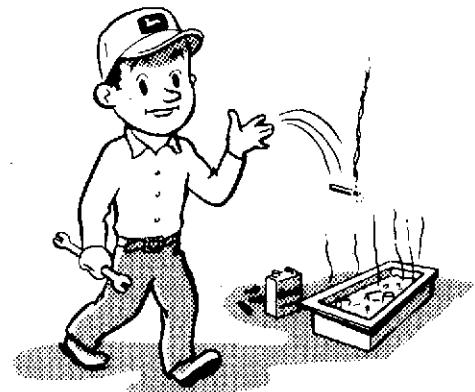

N25286

Handle all flammable fuels or materials carefully.

Transport and store gasoline and oil only in approved containers; do not keep liquid fuels in bottles that may break or pans that may spill.

Know where the nearest fire extinguisher is kept and how to use it.

Do not use an open flame to light dark areas.

Remember that dust and the vapors from storage batteries can be dangerously explosive.



Always avoid loose clothing or any accessory—lopping cuffs, dangling neckties and scarves—that can catch in moving parts and put you out of work.

Always wear your safety glasses while on the job.

Do not wear greasy or fuel soaked clothing.

FLUIDS UNDER PRESSURE

Escaping fluid under pressure can have sufficient force to penetrate the skin, causing serious personal injury. Before disconnecting lines, be sure to relieve the pressure. Before applying pressure to the system, be sure all connections are tight and that lines, pipes and hoses are not damaged. Fluid escaping from a very small hole can be almost invisible. Use a piece of cardboard or wood, rather than hands, to search for suspected leaks.

Keep tractor transmission and brake control units properly adjusted at all times. Before making adjustments on thinner, stop tractor engine.

Before removing any housing covers, stop tractor engine. Take all objects from your pockets which could fall into the opened housings. Don't let adjusting wrenches fall into opened housings.

Before repairing the electrical system, make sure the alternator is not running.

Avoid working on equipment with the tractor engine running. If it is necessary to make checks with the engine running, ALWAYS USE TWO PEOPLE—with an operator at the controls who can see the person doing the checking. Also, put the transmission in neutral, set the brake, and apply safety locks. KEEP HANDS AWAY FROM MOVING PARTS.

Use extreme caution in removing drain plugs, grease fittings, or hydraulic pressure caps.

If injured by escaping fluid, see a doctor at once. Serious infection or reaction can develop if proper medical treatment is not administered immediately.

Don't forget the hydraulic system may be pressurized! To relieve pressure, follow the recommended procedure (see page 20-5-2).

When checking hydraulic pressure, be sure to use the correct test gauge for the highest pressure which may occur in the system being tested.

Section 10 GENERAL

CONTENTS OF THIS SECTION

GROUP 5 - SPECIFICATIONS

	Page
Description	5-3
Advance Planning	5-4
Specifications	5-5

GROUP 10 - LUBRICATION

	Page
General Information	10-1
Lubrication	10-1

GROUP 15 - DIAGNOSING MALFUNCTIONS

Diagnosing Malfunctions	15-1
-------------------------------	------

Group 5 SPECIFICATIONS

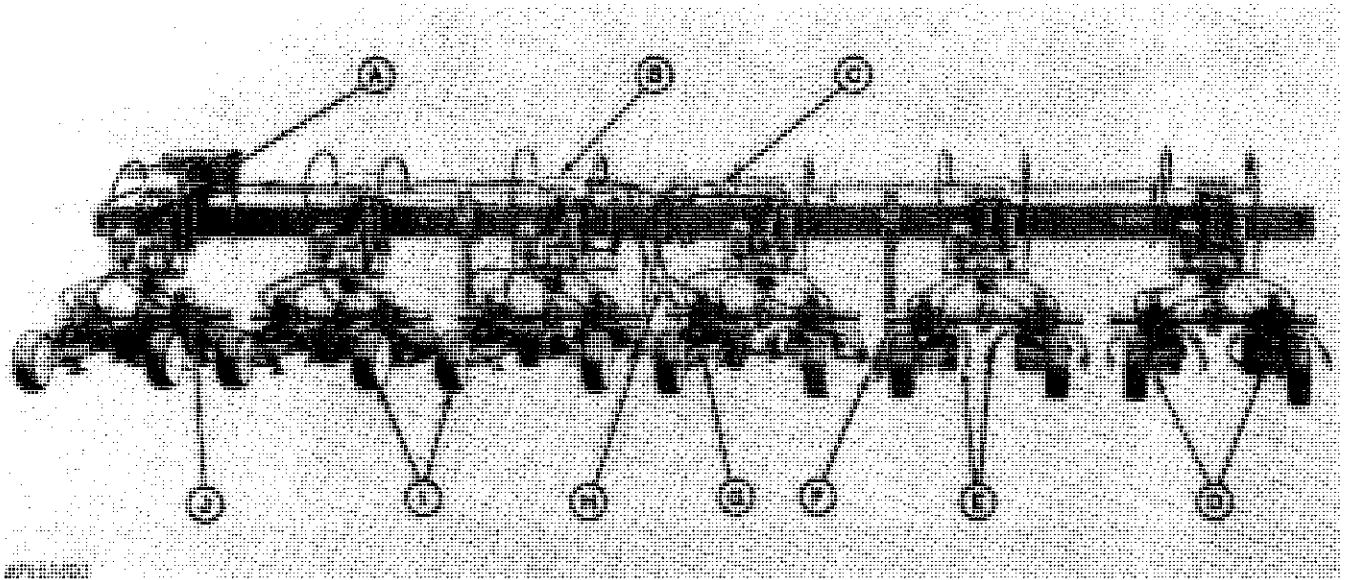

- | | | | | |
|--------------|----------|--------------|---------|-------------------------|
| A—Alternator | C—Switch | E—Shields | G—Probe | I—Gauge Wheels |
| B—Amplifier | D—Knives | F—Corrugator | H—Hoses | J—Actuator and Solenoid |

Fig. 1-200 Thinner - Twelve Rows -
 Two Rows Per Rig

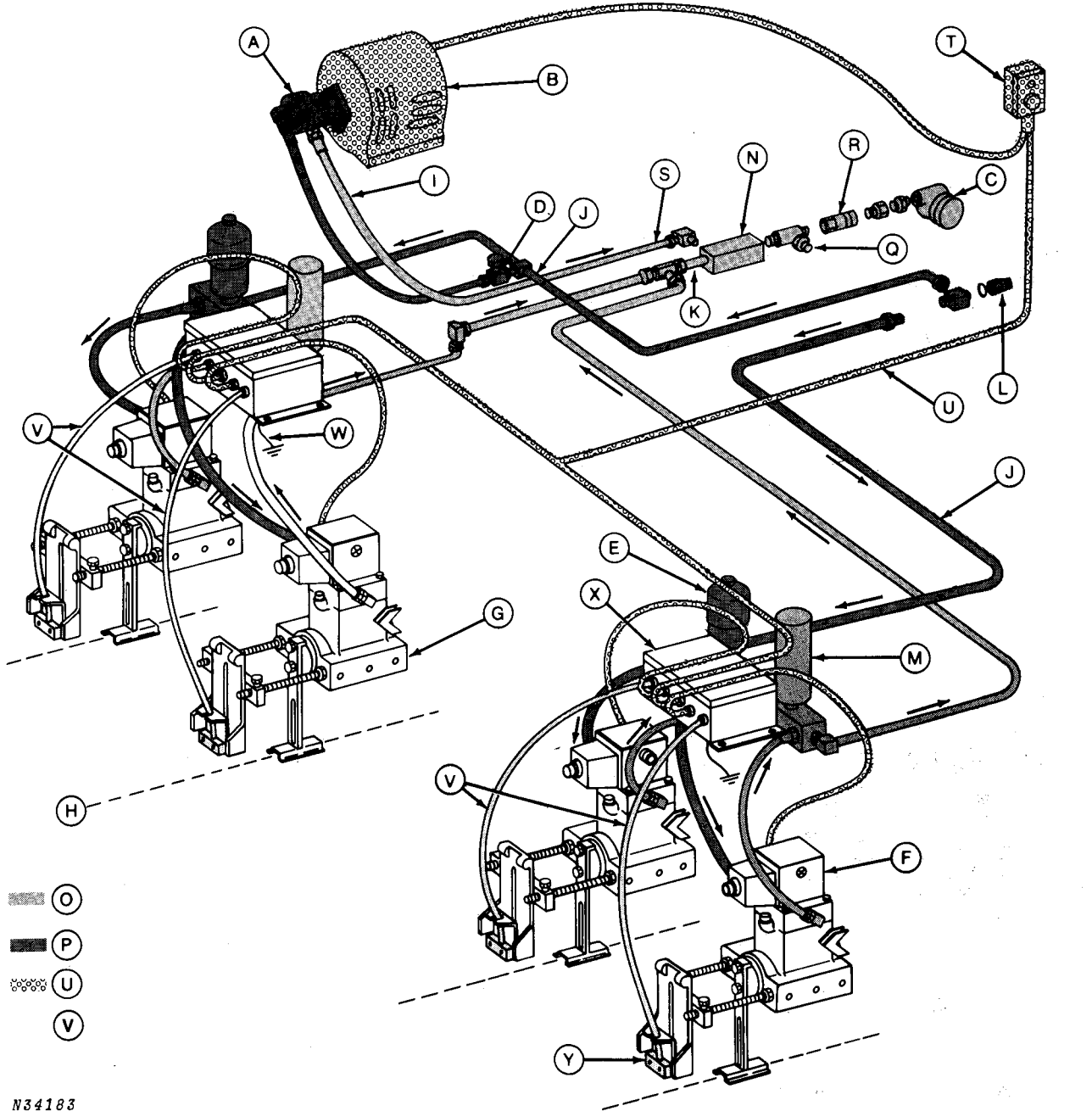

N34183

- | | | | |
|-----------------------------|---|----------------------------------|------------------|
| A—Hydraulic Motor | *I —80-150 PSI (5.5 - 10 bar
[5.6 - 11 kg/cm ²]) | M—Low Pressure Accumulator | T —Switch |
| B—Alternator | J—2000 PSI (138 bar
[141 kg/cm ²]) | *N—Back Pressure Valve | U—125 Volts |
| C—Tractor Filter Cover | *K—50-100 PSI (3.4 - 7 bar
[3.5 - 7 kg/cm ²]) | O—Return Oil | V—11 Volts |
| D—Flow Control Valve | L—To Remote Cylinder Outlet
in Tractor | P—High-Pressure Oil | W—Ground |
| E—High Pressure Accumulator | | Q—Safety Relief Valve | X—Amplifier |
| F—Solenoid Valve | | R—Quik-Coupler | Y—Solenoid Valve |
| G—Actuator | | **S—To Tractor Lube
Test Port | Z—Probe |
| H—Plant Row | | | |

Fig. 2-Thinner Hydraulic and Electrical Schematic

***IMPORTANT:** Do not use the back pressure valve (I, Fig. 2) if tractor back pressure exceeds 100 psi (7 bar [7 kg/cm²]). Always use safety relief valve (Q) whenever quik-coupler (R) is used.

Description

The John Deere 200 Synchronous Thinner will thin crops planted under a wide variety of conditions. The operating principle of all versions is the same. The distinctions concern the type of row units and the number of rows or seedlines each is designed to thin.

Thinning units may be the standard two rows per rig configuration, or the optional one row per rig version which provides increased flexibility to match irregular ground contours. Either version will accommodate a wide range of row spacings. (See pages 10-5-4 and 5.)

The wider spaced units are suitable for crops such as cotton and sugarbeets. The narrow spaced row units are ideal for crops planted two seedlines per bed, such as lettuce, broccoli and cabbage.

HOW IT WORKS

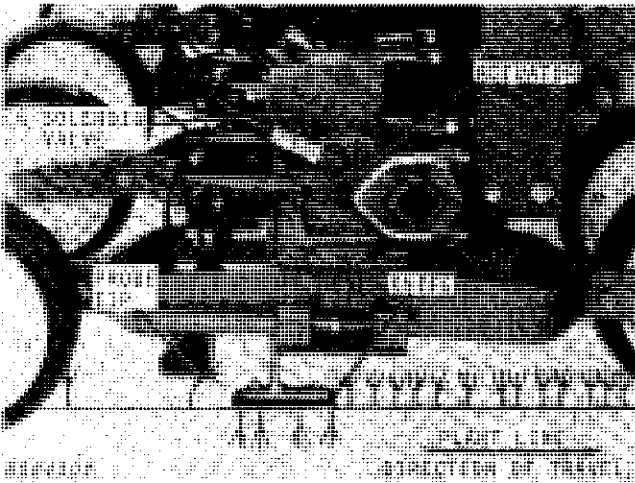

The knife action is synchronized with the plant locations in the seedline. This selective thinning action assures retention of a greater number of evenly spaced plants than would be the case with the random thinning of a fixed-interval knife action.

As the thinner row unit approaches the plant, the operation begins when the plastic shield on the probe touches the edge of a leaf. The shield folds the leaves forward until the probe is over the center of the plant. This is to prevent the leaves from contacting the electronic probe, which would activate the knife too soon.

As the unit continues to move along the row, the electronic probe touches the plant midway between top and bottom. The plant completes an electric circuit, which generates a signal to a solenoid valve. The valve directs hydraulic oil to activate a piston in the actuator, instantly moving the knife.

The knife swings across the row at an extremely high speed. (From the time the probe touches the plant until the knife completes its swing, time lapse is only 0.028 second.) This speed assures that the knife will pass close enough to the plant sensed to leave single plants and provides enough force to cut out excess plants, for a distance slightly longer than the length of the knife.

At the end of the swing across the row in one direction, the knife and knife arm are stopped hydraulically, and the probe circuit is shut off for a period determined by the delay setting on the amplifier. When the shield and probe contact the next plant, the same series of electrical and hydraulic actions take place; the knife swings back across the plant line, again clearing out excess plants. As the process is repeated along the row, a stand of young plants is left to mature, properly spaced for the desired growth.

SPECIFICATIONS

Model 200
Type Selective electronic
Operating speed 1-1/2 to 3-1/4 mph
(2.4 to 5.2 km/h)

Knife Arm Stroke Arc 66 degrees
Stroke Time 28 milliseconds (from time
probe senses plant until arc is completed).

Versions:

For crops planted in single and double seedlines,
flatland or bedded; 2-row and 4-row (early models
only); 6-row, 8-row and 12-row (later models only).
Two-rows or single-row per rig on all except 2-row
and 6-row offset.

Weight (varies by model)

6-row (approx.) 1,700 lb.
(771 kg)

Carrier for attaching thinner to tractor

3-point hitch 4x4-inch
(102x102 mm) or 5x7-inch
(127x178 mm) frame

Tractor Hydraulic Requirements

Two remote hydraulic outlets required for 12-row, one
required on other models.

2000-2300 psi (138-159 bar [141-162 kg/cm²]) pres-
sure, with following capacity:

6 (or less) Rows - 13 gpm (49.2 Lpm)
8 Rows - 16 gpm (60.6 Lpm)
12 Rows - 19 gpm (71.9 Lpm)

Minimum of 50 psi (3.5 bar or kg/cm²) back pressure in
hydraulic return line from thinner. Back pressure valve
is available if needed (see "Attachments").

MACHINE CAPABILITY TABLES

LATE MODELS (1978-)

No. of Rows	Row Spacing Inches (Metres)	Frame Length Inches (Metres)	Rows Per Rig	Bed Spacing Inches (Metres)
4x4-In. (102x102 mm) Frame				
6	16-24 (0.41-0.61)	144 (3.7)	2	
6	12-15 (0.30-0.38)	144 (3.7)	2	38-42 (0.97-1.07)
6	26-34 (0.66-0.86)	170 (4.3)	2	
6	34-40 (0.86-1.02)	194 (4.9)	2	
6 (Skip Row)	44-48 (1.1-1.2)	194 (4.9)	2	
6	16-24 (0.41-0.61)	144 (3.7)	1	
6	12-15 (0.30-0.38)	144 (3.7)	1	38-42 (0.97-1.07)
6	26-34 (0.66-0.86)	194 (4.9)	1	
8	16-24 (0.41-0.61)	170 (4.3)	2	
8	26-30 (0.66-0.76)	194 (4.9)	2	
8	12-15 (0.30-0.38)	144 (3.7)	2	38-42 (0.97-1.07)
8	16-24 (0.41-0.61)	194 (4.9)	1	
8	12-15 (0.30-0.38)	170 (4.3)	1	38-42 (0.97-1.07)
5x7-In. (127x178 mm) Frame				
12	22-24 (0.56-0.61)	260 (6.6)	2	
12	22 (0.56)	260 (6.6)	1	

**EARLY MODELS
 (Prior to 1978)**

No. of Rows	Row Spacing (Inches) (Metres)	4" x 4" (102 x 102 mm) Frame Length (Inches) (Millimetres)	Rows Per Rig	Bed Spacing (Inches) (Millimetres)
2	16 to 30 (0.41 to 0.76)	59 (1 499)	2	
4	16 to 48 (0.41 to 1.22)	144 (3 658)	2	
4	16 to 44 (0.41 to 1.12)	144 (3 658)	1	
4	12 to 15 (0.31 to 0.38)	144 (3 658)	2	38 - 42 (965 - 1 067)
4	12 to 15 (0.31 to 0.38)	144 (3 658)	1	38 - 42 (865 - 1 067)
4	45 to 48 (1.14 to 1.22)	170 (4 318)	1	
6	16 to 30 (0.41 to 0.76)	144 (3 658)	2	
6	16 to 26 (0.41 to 0.66)	144 (3 658)	1	
6	12 to 15 (0.31 to 0.38)	144 (3 658)	2	38 - 42 (965 - 1 067)
6	12 to 15 (0.31 to 0.38)	144 (3 658)	1	38 - 42 (965 - 1 067)
6	32 to 40 (0.81 to 1.02)	170 (4 318)	2	
6	27 to 32 (0.69 to 0.81)	170 (4 318)	1	
6 (Skip Row)	44 to 48 (1.12 to 1.22)	194 (4 920)	2	
6	33 to 36 (0.84 to 0.91)	194 (4 920)	1	
8	16 to 20 (0.41 to 0.51)	170 (4 318)	2	
8	16 to 18 (0.41 to 0.46)	170 (4 318)	1	
8	12 to 15 (0.31 to 0.38)	170 (4 318)	2	38 - 42 (965 - 1 067)
8	12 to 15 (0.31 to 0.38)	170 (4 318)	1	38 (965)
8	21 to 26 (0.53 to 0.66)	170 (4 318)	2	
8	19 to 22 (0.48 to 0.56)	170 (4 318)	1	
8	12 to 15 (0.31 to 0.38)	170 (4 318)	1	40 - 42 (1 016 - 1 067)
8	27 to 30 (0.69 to 0.76)	194 (4 920)	2	
8	23 to 26 (0.58 to 0.66)	194 (4 920)	1	

SPECIFICATIONS—(Continued)

TRACTOR REQUIREMENTS

Tractor must be equipped with the following:

Category 2, 3, or 3N, 3-Point Hitch

Refer to tractor operator's manual for tire restrictions and front end weight recommendations.

AMPLIFIER FUSES

Two Bussman Type GMW, 3-Amp, JD No. AN131761

One Bussman Type MDL, 1/2-Amp Slow-Blow, JD No. AN180119

NOTE: Slow-Blow fuse is located UNDER the amplifier chassis on early models. See page 40-15-2.

ELECTRICAL SWITCH

Single-pole, single-throw, push-pull type.

Pilot bulb Type 51

ACCUMULATORS

One high-pressure and one low-pressure accumulator for each two rows.

The high-pressure accumulator has a preset nitrogen pressure of 69 ± 3 bar (7 ± 3 kPa [1000 ± 50 psi]).

The low-pressure accumulator has a preset nitrogen pressure of 75 psi ± 5 psi (5 ± 0.3 bar) (5 ± 0.35 kg/cm²)

ACTUATORS

Oil capacity—11 fluid ounces (326 mL)

Type of Oil—JD HY-GARD® or equivalent

Type—2-piston

Solenoid voltage—125 volts

Stroke time—0.028 seconds

ALTERNATOR

Hydraulic motor driven (Variable flow control)

Output: 125 volts, 1800 Watts (Early Models)

125 volts, 2,000 Watts (Later Models)

KNIVES

4-, 5-, 6-, 7-, 8-, 9-, 10-, 11-, and 12-inch (102, 152, 178, 203, 229, 254, 279, and 305 mm) knives are optional equipment.

GUIDANCE SYSTEMS

Cone guide wheels

Guide coulter(s)

Corrugators

ATTACHMENTS

High Flotation Gauging

Quick-Coupler and Safety Valve

Back Pressure Valve

6-Row Offset Conversion

Knife arm flaps (for tall crops)

Recommended Torque Value in Foot-Pounds (Nm [kgm])
Coarse and Fine Threads

Bolt Diameter	Three Radial Dashes	Six Radial Dashes
1/4	10 (14 [1.4])	14 (19 [1.9])
5/16	20 (27 [2.8])	30 (41 [4.1])
3/8	35 (47 [4.8])	50 (68 [6.9])
7/16	55 (75 [7.6])	80 (101 [11])
1/2	85 (115 [12])	120 (163 [17])
9/16	130 (176 [18])	175 (237 [24])
5/8	170 (230 [23])	240 (325 [33])
3/4	300 (407 [41])	325 (576 [59])
7/8	445 (603 [61])	685 (928 [95])
1	670 (908 [92])	1030 (1396 [142])

Group 10 LUBRICATION

GENERAL INFORMATION

Carefully written and illustrated lubrication instructions are included in the operator's manual furnished with your customer's machine. Remind him to follow these instructions.

For your convenience, the following chart shows capacities and types of lubricants for the thinner components and systems. Specifications for lubricants follow the chart.

LUBRICATION CHART

Location	Capacity	Type of Lubricant
Grease Fittings	John Deere Multi-Purpose Lubricant or equivalent SAE multi-purpose grease
Actuator Crankcase (Add through breather elbow)	11 fluid ounces (326 mL)	John Deere HY-GARD Transmission and Hydraulic Oil or its equivalent

TRANSMISSION-HYDRAULIC SYSTEM OILS

Use only John Deere HY-GARD Transmission and Hydraulic Oil or its equivalent in the transmission-hydraulic system. Other types of oil will not give satisfactory service, and may result in eventual damage. This special oil, available from your John Deere dealer, may be used in all weather conditions.

NOTE: John Deere HY-GARD Transmission and Hydraulic Oil may be added to or mixed with John Deere Type 303 Special-Purpose Oil.

GREASES

John Deere Multi-purpose lubricant or equivalent SAE multipurpose-type grease is recommended for all grease fittings. Application of grease as instructed in the lubrication chart will provide proper lubrication and will prevent contamination of bearings.

STORING LUBRICANTS

This thinner can operate efficiently only if clean lubricants are used. Store them in an area protected from dust, moisture, and other contaminants.

Group 15 DIAGNOSING MALFUNCTIONS

Doubles (Two Plants Saved)

Adjustments - See Operator's Manual
Probe and shield assembly set too high.
Probe too high in relation to shield.
Probe set too far behind knife.
Probe plate dirty.
Ground speed too fast in relation to knife length and amplifier delay switch setting.
Knife not level.
Row unit not centered.

Advance Planning - See Operator's Manual
Ground too uneven to allow uniform contact of plant.
Hydraulic System Malfunction - See Section 30
Accumulators precharge too low.
Hydraulic volume too low.
Electrical System Malfunction - See Section 40
Voltage too low.
Amplifier sensitivity too high.
Amplifier timing incorrect.

Skips (Extra Plant Taken Out By Knife)

Adjustments - See Operator's Manual.
Probe too low in relation to shield.
Probe too high.
Probe too close to knife.
Plants too large.
Knife cutting too deep.
Advance Planning - See Operator's Manual
Clods, weeds, or trash in plant row.
Electrical System Malfunction - See Section 40
Probe shorted to shield.
Amplifier switch setting too high.

Knife Oscillates Continuously and Uniformly

Electrical System Malfunction - See Section 40
Plant or dirt shorting probe to frame or ground.
Probe wire shorting to ground.
Moisture in amplifier box.
Amplifier improperly grounded.
Any one of three wires loose or disconnected.

Erratic Thinning

Adjustments - See Operator's Manual
Probe and/or actuator not aligned with row.
Probe dirty.
Gauge wheels too far from plant row.
Probe too high.
Hydraulic System Malfunction - See Section 30
Hydraulic oil volume too low.
High pressure accumulator charge too high.

Electrical System Malfunction - See Section 40
Voltage too low.
Amplifier improperly grounded.
Machine not grounding because of dry ground.
Broken electrical wire or loose connections.

Knife Makes Two Strokes For Each Plant

Electrical System Malfunction - See Section 40
Improper amplifier switch setting.

Knife of One Row Chatters

Actuator and Solenoid Valve Malfunction - See Sections 20 and 40.
Wire from amplifier to solenoid coil loose or broken.
Solenoid valve defective.
Hydraulic system malfunction - See Section 30.
Voltage too low.
Dirty hydraulic oil.
Defective AC module.
Valve spool stuck.

Two Knives Actuate As a Result of One Probe Contacting Plant

Electrical System Malfunction - See Section 40
Loose power supply wire.
Broken supply wire.
Loose or broken amplifier-to-solenoid wire on unit not contacted.
Fuse not tight in socket.

Two or More Knives Operate When One Probe Is Contacted

Electrical System Malfunction - See Section 40
Electrical power source is being interrupted.
Alternator voltage output in excess of 150 volts.

No Electrical Power

Hydraulic System Malfunction - See Section 30
Hydraulic motor defective.
Flow control valve defective.
Electrical System Malfunction - See Section 40
Electrical switch defective.
Alternator defective or not operating.
Brushes worn or misaligned.

Solenoid Valve Not Working

Electrical System Malfunction - See Section 40
Coil burned out.
Wires broken or disconnected.
Valve Malfunction - See Section 30
Stiff or locked spool.
Core O-rings leaking.

Section 20

ACTUATOR AND SOLENOID VALVE

CONTENTS OF THIS SECTION

	Page		Page
GROUP 5 - ACTUATOR		GROUP 10 - SOLENOID VALVE	
General Information	5-1	Description	10-1
Diagnosing Malfunctions	5-1	Diagnosing Malfunctions	10-1
Removal	5-2	Testing the Solenoid Valve	10-1
Installation	5-2	Removing Solenoid Valve	10-2
Disassembly	5-4	Installing Solenoid Valve	10-2
Inspection and Repair	5-7	Valve Disassembly, Inspection, Repair and Assembly	10-3
Assembly	5-9	Checking Valve Housing for Cracks	10-3
Making Special Tools	5-14		
		GROUP 15 - SPECIFICATIONS, TORQUE VALUES, AND SPECIAL TOOLS	
		Specifications	15-1
		Torque Values	15-1
		Special Tools	15-1

Group 5 ACTUATOR

GENERAL INFORMATION

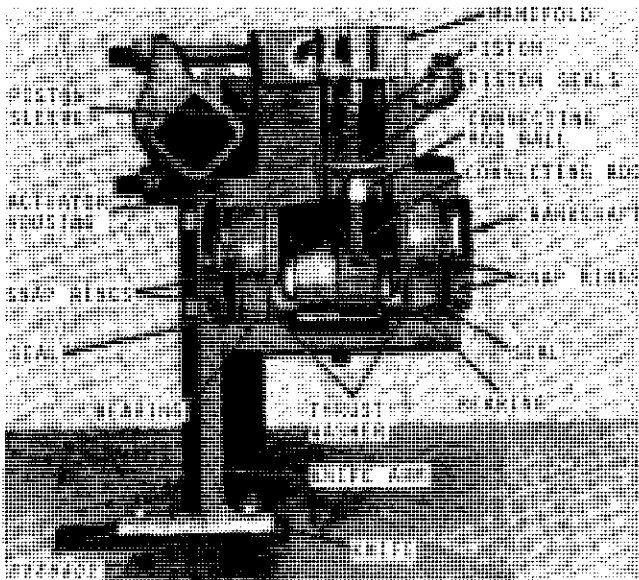

Fig. 1-Cutaway View of Actuator

The actuator is a hydraulic motor consisting of the following components:

1. Actuator housing.
2. Two pistons with connecting rods and connecting rod balls.
3. Crankshaft.

4. Two bearings, thrust washers, seals and four snap rings.

The actuator action is started by a signal from the probe circuit when a plant is touched. This signal controls the power to the solenoid valve. The valve directs hydraulic oil to a piston which moves the knife through the row. When the probe touches the next plant the signal is interrupted and the valve spool is shifted by a spring. This directs the hydraulic oil to the other piston and moves the knife back across the row, completing the cycle.

DIAGNOSING MALFUNCTIONS

EXCESSIVE OIL LEAKAGE OUT OF BREATHER IN SPURTS OR A CONTINUOUS FLOW WHEN OPERATING

- Piston ring defective, page 20-5-9.
- Breather defective, page 20-5-8.
- Oil level too high in actuator crankcase, page 20-5-2.

OIL LEAKING FROM AROUND CRANKSHAFT

- Crankshaft seal defective, page 20-5-11.

OIL LEAKING AROUND BOTTOM OF VALVE

- Manifold defective—Check for cracks with spot-check, page 20-5-8.
- Valve defective, page 20-10-3.
- Valve-to-manifold O-rings defective, page 20-10-3.

DIAGNOSING MALFUNCTIONS —Continued

ACTUATOR DOES NOT FUNCTION OR IS SLUGGISH

- Scored or broken pistons, page 20-5-7.
- Scored or broken connecting rods, page 20-5-7.
- Broken or wedged ball, page 20-5-7.
- Crankshaft bearings defective, page 20-5-7.
- Valve spool sticking, page 20-10-3.
- Valve return spring broken, page 20-10-3.
- Hydraulic system pressure and flow too low, page 30-5-3.
- Back-pressure valve defective, page 30-20-3.
- Faulty quick coupler on return hose defective, page 30-20-3.

KNIFE ARM WEARING ON ACTUATOR HOUSING

- Thrust washer(s) defective or left out, page 20-5-6.

REMOVAL

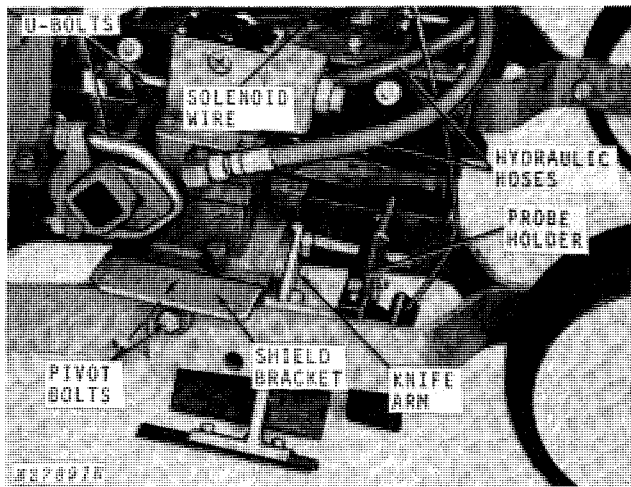

Fig. 2-Removing Actuator (Outer Shield Removed)

CAUTION: Escaping hydraulic oil under pressure can cause personal injury; therefore, be sure all connections are tight and that lines and hoses are not damaged. Before disconnecting lines in the thinner hydraulic system, be sure to relieve all hydraulic pressure as follows:

1. Shut off tractor engine and move tractor hydraulic control lever back and forth several times to relieve system pressure. Disconnect pressure hose from tractor hydraulic outlet and loosen coupler on end of hose SLOWLY, using a shop towel to absorb any escaping hydraulic fluid, until all pressure is relieved.

2. Remove drain plug at bottom of actuator and drain hydraulic fluid.

3. Disconnect the pressure and return hydraulic hoses from the actuator manifold.

Litho in U.S.A.

IMPORTANT: Cap or plug hoses and connectors to keep dirt out of system and retain hydraulic fluid.

4. Remove shields to gain access to pivot bolts.
5. Remove pivot bolts to free gauge wheel frame.
6. Disconnect solenoid wire at the amplifier.
7. Loosen nuts on U-bolts and lift actuator out and away from rig hanger and gauge wheels.

NOTE: Remove shield brackets, if desired, by removing the additional cap screw.

8. Remove lug bolts to remove knife arm with knife.

INSTALLATION

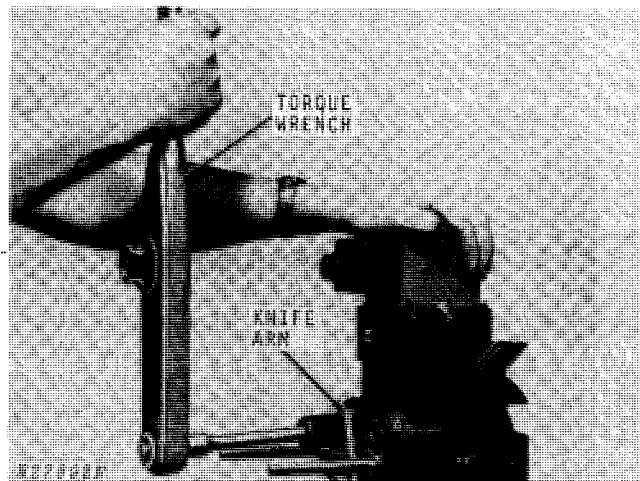

Fig. 3-Installing and Tightening Knife Arm

1. Bolt the knife arm and knife to the actuator crankshaft with two lug bolts and tighten to 100 to 120 ft-lbs (136-163 Nm [14-17 kgm]) torque.

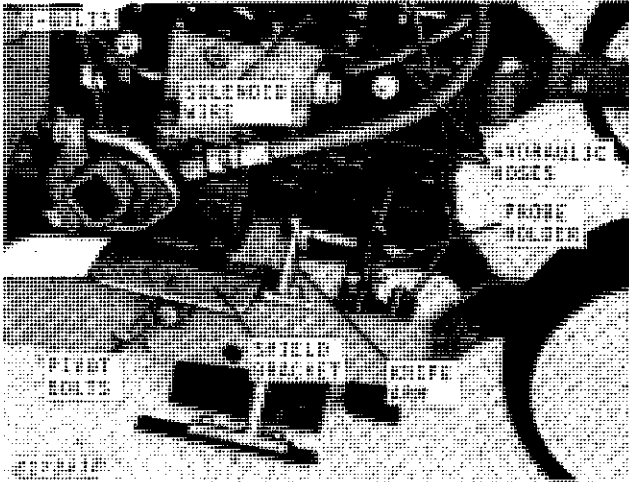

Fig. 4-Installing Actuator

2. Attach shield brackets to actuator (if removed) with one screw in an outer hole.

3. Mount the actuator on the actuator bar with U-bolts. Leave nuts loose.

4. Connect solenoid wire to amplifier.
5. Attach gauge wheel frames with pivot bolts through CENTER hole of shield brackets and actuator. Be sure to use bushings in each frame.
6. Install probe holder; position it to clear knife arc, and tighten screws.
7. Connect hydraulic hoses to manifold as indicated by "P" (pressure) and "R" (return) markings above the ports.
8. Position the actuator for the desired row spacing and tighten nuts on U-bolts.
9. Remove dipstick from actuator and install 11 oz. (326 mL) of Hy-GARD Transmission and Hydraulic Oil or its equivalent in the crankcase. Check oil level to be sure it is between "HIGH" and "LOW" marks on dipstick.

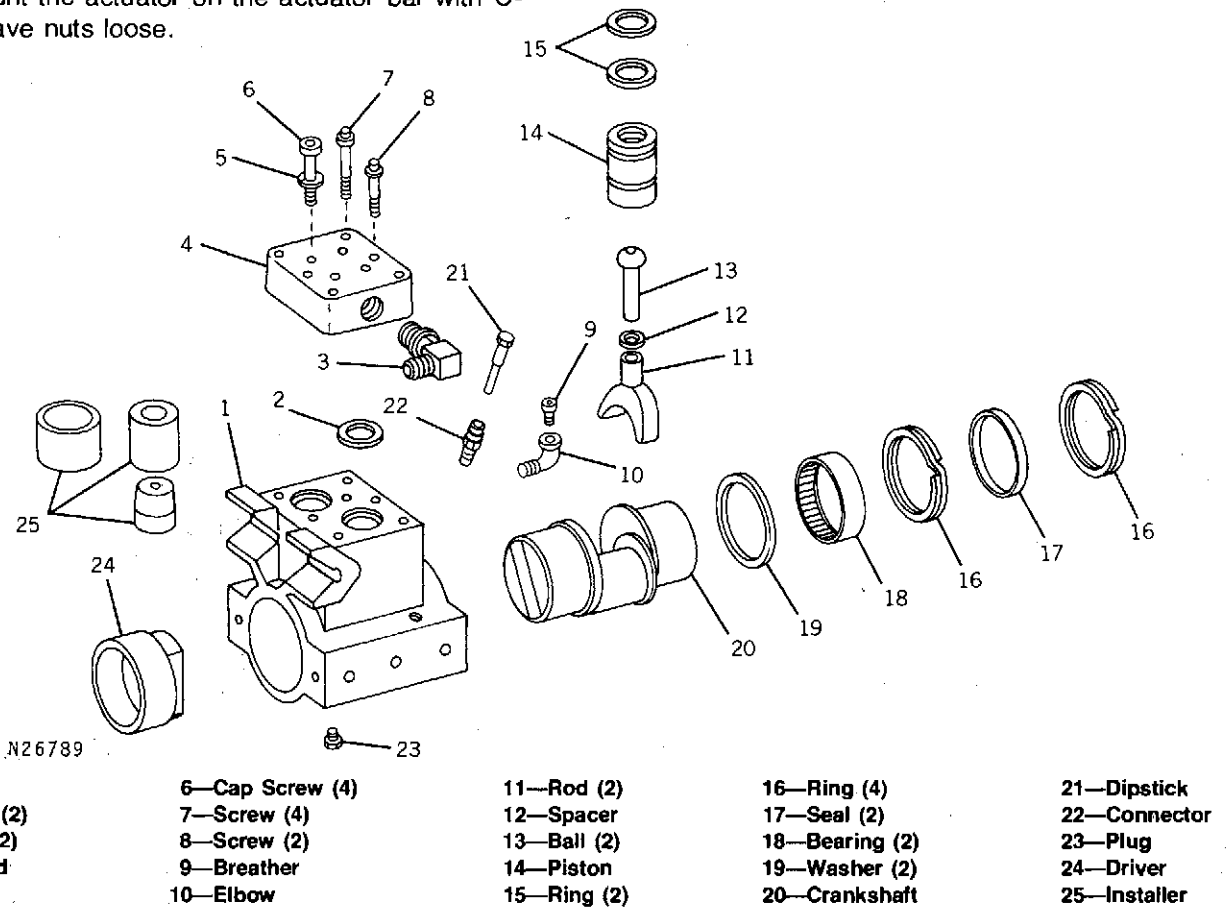

Fig. 5-Actuator Components

DISASSEMBLY

Disassemble the actuator in the following steps to repair damaged parts or to replace leaky O-rings or seals:

1. Clean all dirt and oil from the actuator.
2. Position knife arm in bottom dead center position and remove arm and knife.

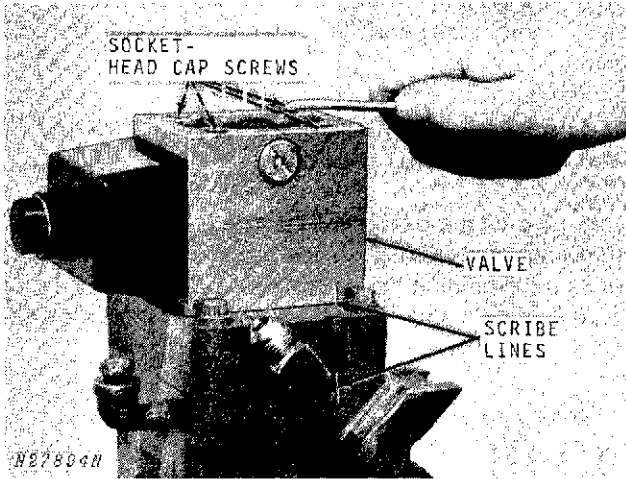

Fig. 6-Removing Solenoid Valve

3. Scribe the valve body, manifold, and actuator to aid reassembly, Fig. 6.
4. Remove cover plate and gasket from top of valve.
5. Remove the four 1/4 x 2-3/4-inch socket head cap screws that hold the valve to the actuator manifold, Fig. 6.

IMPORTANT: Do not lose the lock washers on these bolts.

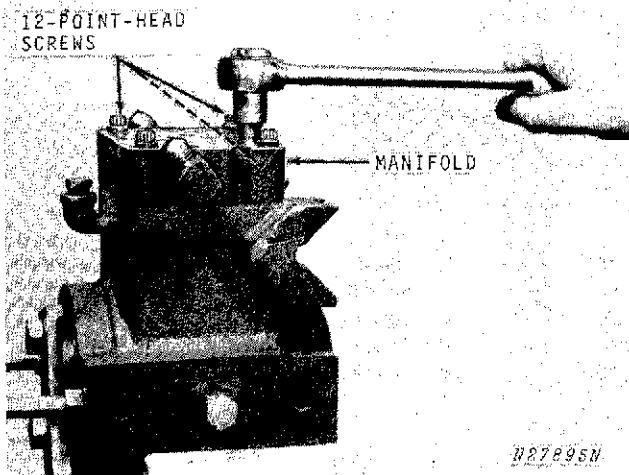

Fig. 7-Removing Actuator Manifold

6. Remove the two 3/8 x 1-1/2-inch 12-point-head screws in the middle of the manifold, Fig. 7.

7. Remove the four 3/8 x 2-inch 12-point-head screws on the outside of the manifold, Fig. 7.

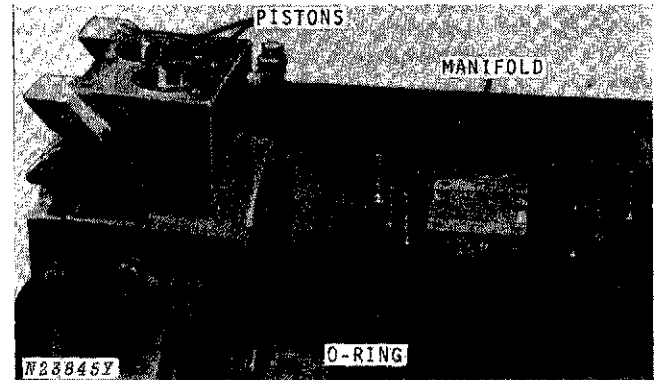

Fig. 8-Removing Pistons and Manifold

8. After manifold is removed, remove the two O-rings and discard.
9. Remove the pistons. The groove in the hole in the center of the piston is provided as a gripping point for pulling the piston out. Remove piston Teflon seal and square cut rings, and discard.

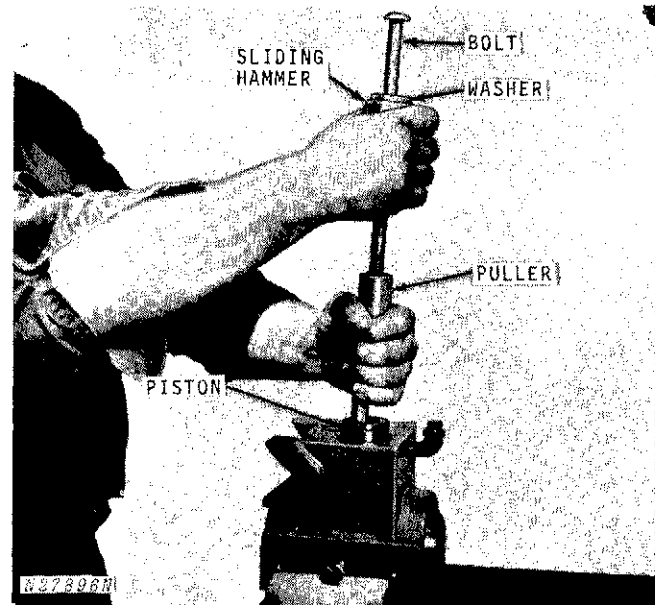

Fig. 9-Removing Piston with Piston Puller

10. If piston has seized or is too tight to be removed by hand, it may be necessary to remove piston with a piston puller. See Figs. 42 and 43, page 20-5-14, for instructions for making a piston puller.

NOTE: Blind Hole Puller Set D-01061AA, available through the SERVICEGARD Equipment Program, may be used for this job. Use 1-1/4" (32 mm) Collet.

Position puller in groove in the hole in the center of the piston. Hold puller in position and slide hammer sharply against washer and bolt to remove piston.



Suggest:

If the above button click is invalid.

Please download this document

first, and then click the above link

to download the complete manual.

Thank you so much for reading

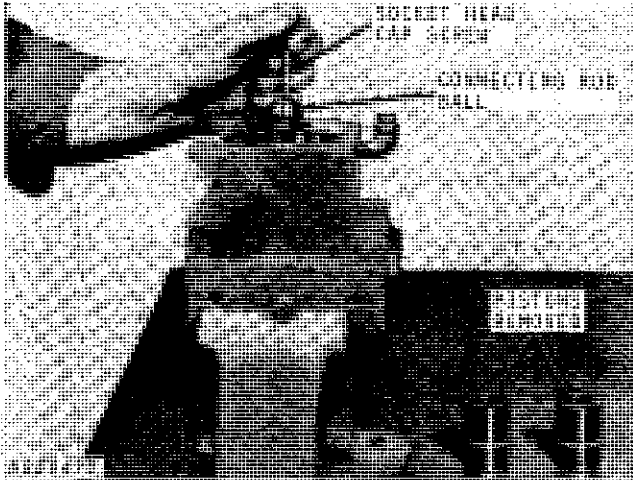

Fig. 10-Removing Connecting Rod Ball

11. Use a socket head cap screw removed from the valve to remove the connecting rod balls.

IMPORTANT: Remove lock washer from screw to prevent dropping it in the crankcase. Screw the cap screw into the ball and remove through the piston hole.



Fig. 11-Removing Outer Snap Ring

12. Remove breather, oil level check plug assembly, and bolt.

13. Remove the outer snap ring from both sides, Fig. 11.

IMPORTANT: Do not pull up sharply on snap ring when removing because this may distort or break snap ring.

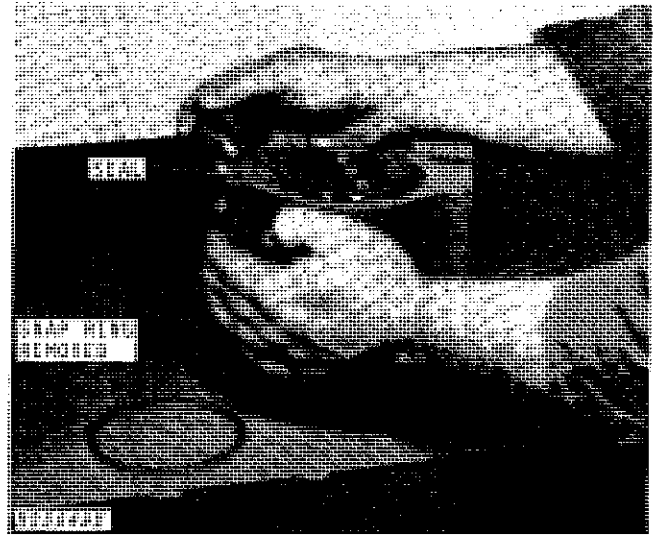

Fig. 12-Removing Seal

14. Remove seal from both sides of crankshaft. Do not save these seals. Replace both seals when reassembling actuator. An actuator seal kit is available which includes all actuator seals and O-rings.



Fig. 13-Removing Bearing Retainer Snap Ring

15. Remove the bearing retainer snap ring from both sides of the actuator crankshaft.

IMPORTANT: Do not pull up sharply on snap ring when removing because this may distort or break snap ring.

<https://www.ebooklibonline.com>

Hello dear friend!

Thank you very much for reading.

Enter the link into your browser.

The full manual is available for immediate download.

<https://www.ebooklibonline.com>