

JOHN DEERE
WORLDWIDE COMMERCIAL & CONSUMER
EQUIPMENT DIVISION

Rear Bagger and Power Flow™
7 Bushel

OMTCU15755 C2

OPERATOR'S MANUAL



JOHN DEERE

North American Version
Litho in U.S.A.

INTRODUCTION

Thank You for Purchasing a John Deere Product

We appreciate having you as a customer and wish you many years of safe and satisfied use of your machine.

Using Your Operator's Manual

This manual is an important part of your machine and should remain with the machine when you sell it.

Reading your operator's manual will help you and others avoid personal injury or damage to the machine. Information given in this manual will provide the operator with the safest and most effective use of the machine. Knowing how to operate this machine safely and correctly will allow you to train others who may operate this machine.

If you have an attachment, use the safety and operating information in the attachment operator's manual along with the machine operator's manual to operate the attachment safely and correctly.

This manual and safety signs on your machine may also be available in other languages (see your John Deere dealer to order).

Sections in your operator's manual are placed in a specific order to help you understand all the safety messages and learn the controls so you can operate this machine safely. You can also use this manual to answer any specific operating or servicing questions. A convenient index located at the end of this book will help you to find needed information quickly.

The machine shown in this manual may differ slightly from your machine, but will be similar enough to help you understand our instructions.

RIGHT-HAND and LEFT-HAND sides are determined by facing in the direction the machine will travel when going forward. When you see a broken line arrow (----->), the item referred to is hidden from view.

Before delivering this machine, your dealer performed a predelivery inspection to ensure best performance.

Special Messages

Your manual contains special messages to bring attention to potential safety concerns, machine damage as well as helpful operating and servicing information. Please read all the information carefully to avoid injury and machine damage.



CAUTION: Avoid injury! This symbol and text highlight potential hazards or death to the operator or bystanders that may occur if the hazards or procedures are ignored.

IMPORTANT: Avoid damage! This text is used to tell the operator of actions or conditions that might result in damage to the machine.

NOTE: General information is given throughout the manual that may help the operator in the operation or service of the machine.

PRODUCT IDENTIFICATION

Product Compatibility

The POWER FLOW and 7 Bushel Rear Bagger are compatible with Z-TRAK models 717, 727, 737 and 757.

Record Identification Numbers

POWER FLOW

Serial No. (010001-)

If you need to contact an Authorized Service Center for information on servicing, always provide the product model and serial number.

You will need to locate the serial number for the attachment. Record the information in the spaces provided below.

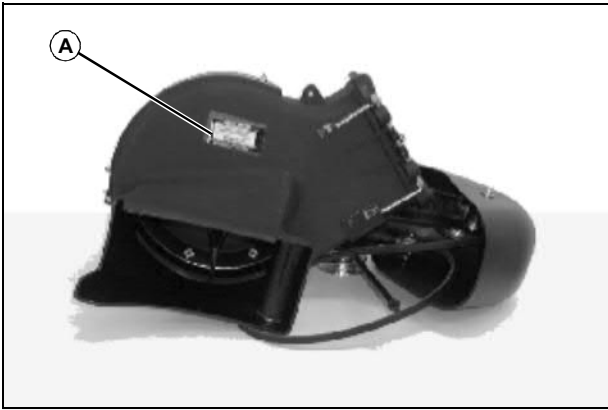

MX12469

DATE OF PURCHASE:

DEALER NAME:

DEALER PHONE:

SERIAL NUMBER (A):

<https://www.ebooklibonline.com>

Hello dear friend!

Thank you very much for reading.

Enter the link into your browser.

The full manual is available for immediate download.

<https://www.ebooklibonline.com>

TABLE OF CONTENTS

Safety	1
Preparing Vehicle	4
Installing	5
Removing	8
Operating	9
Replacement Parts	12
Service Intervals	13
Service	14
Troubleshooting	16
Storage	18
Assembly	19
Specifications	23
Index	24

All information, illustrations and specifications in this manual are based on the latest information at the time of publication. The right is reserved to make changes at any time without notice.

COPYRIGHT© 2002
Deere & Co.
John Deere Worldwide Commercial and
Consumer Equipment Division
All rights reserved
Previous Editions
COPYRIGHT©

OMTCU15755 C2 - English

SAFETY

Understanding The Machine Safety Labels

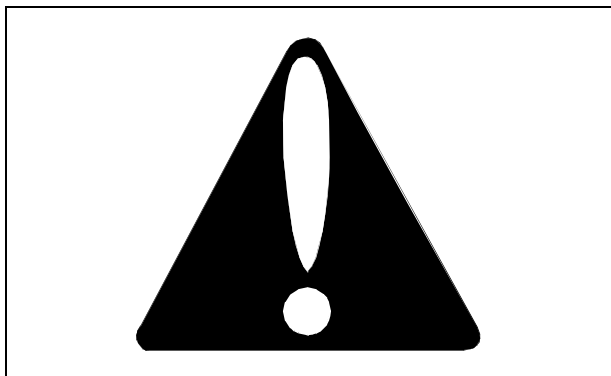

Safety-Alert Symbol

The machine safety labels shown in this section are placed in important areas on your machine to draw attention to potential safety hazards.

On your machine safety labels, the words DANGER, WARNING, and CAUTION are used with this safety-alert symbol. DANGER identifies the most serious hazards.

The operator's manual also explains any potential safety hazards whenever necessary in special safety messages that are identified with the word, CAUTION, and the safety-alert symbol.

WARNING: Rotating Blade-Thrown Objects



MX12469 MX118454

Operate blower with entire grass catcher secured in place.

WARNING



MX12471 M128896

To avoid injury from thrown objects, keep bystanders away. Shut off engine before opening hopper top. Keep chutes in place. Never allow riders on hopper top or on frame.

CAUTION



MX12471 M128896

To avoid injury, ballast per operator's manual. Bag is subject to wear and deterioration, check bag frequently and replace, as necessary, with a John Deere bag or equivalent to comply with safety specifications.

SAFETY

CAUTION

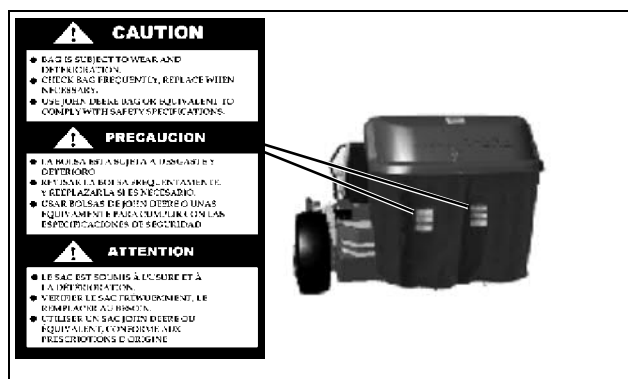

MX12471 GC00215

- Bag is subject to wear and deterioration.
- Check bag frequently and replace when necessary.
- Use John Deere bag or equivalent to comply with safety specifications.

Bagging Safely

Read, understand and follow all instructions in this attachment manual, the vehicle operator's manual and safety signs on equipment before starting.

Use proper front ballast. Remove ballast when the material collection system is removed.

Hopper extends beyond vehicle. Be aware of surrounding objects when making short turns.

Do not operate material collection system unless entire grass catcher is fastened in place with hopper cover securely latched.

Do not let anyone ride on the machine or material collection system. Riders are subject to injury such as being struck by foreign objects or being thrown off. Riders may obstruct the operator's view and cause a collision.

Before you remove or install bags:

- Stop mower.
- Disengage mower PTO.
- Stop engine.

Before you back up:

- Stop machine.
- Look behind hopper for children.

Bag Maintenance:

- Bag is subject to wear and deterioration.
- Check bag frequently, replace when necessary.

- Use John Deere bag or equivalent to comply with safety specifications.

- Do not leave clippings in bags overnight.

Operate safely on slopes:

- Empty bags when they are half full.
- Do not operate on steep slopes.
- Before you turn, slow down.
- Avoid sudden starts and stops.
- Avoid holes, rocks, and roots.
- Mow up and down — not across slopes.
- Do not park mower with material collection system on slopes.

Parking Safely

1. Stop machine on a level surface, not on a slope.
2. Disengage PTO.
3. Lower attachments to the ground.
4. Lock the park brake.
5. Stop the engine.
6. Remove the key.
7. Wait for engine and all moving parts to stop before you leave the operator's seat.
8. Close fuel shut-off valve, if your machine is equipped.

Practice Safe Maintenance

- Never service or adjust the attachment while the vehicle is moving. Keep safety devices in place and in working condition. Keep hardware tight.
- Keep all parts in good condition and properly installed. Fix damage immediately. Replace worn or broken parts. Remove any buildup of debris.
- Unauthorized modifications to the attachment may impair its function and safety. Do not tamper with its original design.

SAFETY

Wear Appropriate Clothing

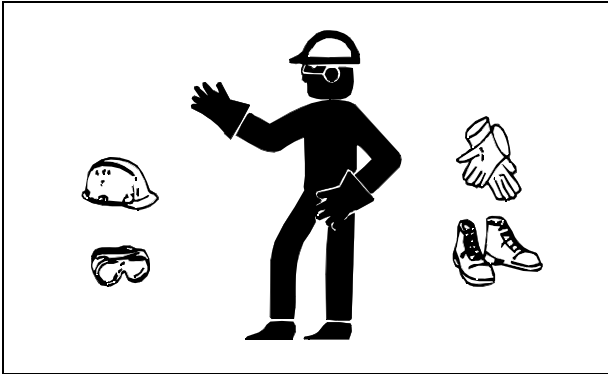

MIF

- Wear close fitting clothing and safety equipment appropriate for the job.
- Always wear safety goggles or safety glasses with side shields when operating the machine.
- Wear a suitable protective device such as earplugs. Loud noise can cause impairment or loss of hearing.
- Do not wear radio or music headphones. Safe service and operation requires your full attention.

Avoid Injury From Thrown Objects

- When operating the vehicle with the attachment installed make sure all chutes and hoses are securely in place.
- Avoid injury from impeller blades and thrown objects. Remove POWER FLOW when operating vehicle in side discharge mode.

Avoid Injury From Rotating Blades



MIF

- Do not put hands or feet near POWER FLOW when engine is running.

- Stop engine before you unplug the POWER FLOW.
- Do not operate the POWER FLOW unless entire grass catcher is fastened in place with hopper cover latched in the CLOSED position.

Avoid Injury From Contacting Blades

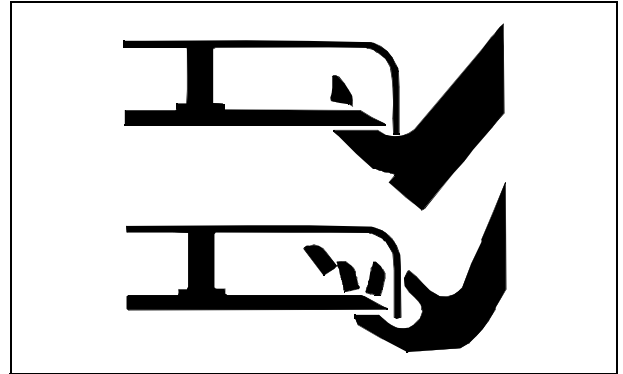

MIF

Before dismounting to unplug the POWERFLOW and chute or adjust the mower:

- Disengage PTO to stop mower blades.
- Stop the engine.
- Lock the park brake.
- Remove key.
- Wait for mower blades to stop.
- Keep hands, feet and clothing away from mower deck when engine is running.

PREPARING VEHICLE

Machine Setup

- Check tire pressure of machine before operating machine.

Install Proper Ballast



CAUTION: Avoid injury! Ballast is required when the attachment is installed.

When the attachment is removed, you must also remove any ballast that was added to the machine.

Use only attachments and accessories recommended by the manufacturer.

Install the proper front ballast to help counter-balance the total weight of the bagger. Remove ballast when the bagger is removed. This will ensure proper operation of the machine when not bagging. See your authorized service center for required weights on your machine.

Installing Proper Mower Blades

IMPORTANT: Avoid damage! When replacing mower blades, always use genuine John Deere Service Parts.

- **For best performance, always use correct mower blade for job being performed.**
- **Always follow safety and service instructions in the machine operator's manual when changing mower blades.**

For maximum performance from your POWER FLOW, install the correct mower blades for your application:

- **Mulching Blades** - Not for use with POWER FLOW.
- **Standard Blades** - Standard blades are designed for bagging, side discharging, and all mowing conditions.



Suggest:

If the above button click is invalid.

Please download this document

first, and then click the above link

to download the complete manual.

Thank you so much for reading

INSTALLING

Installing H-Frame

1. Park machine safely. (See Parking Safely in the SAFETY section.)

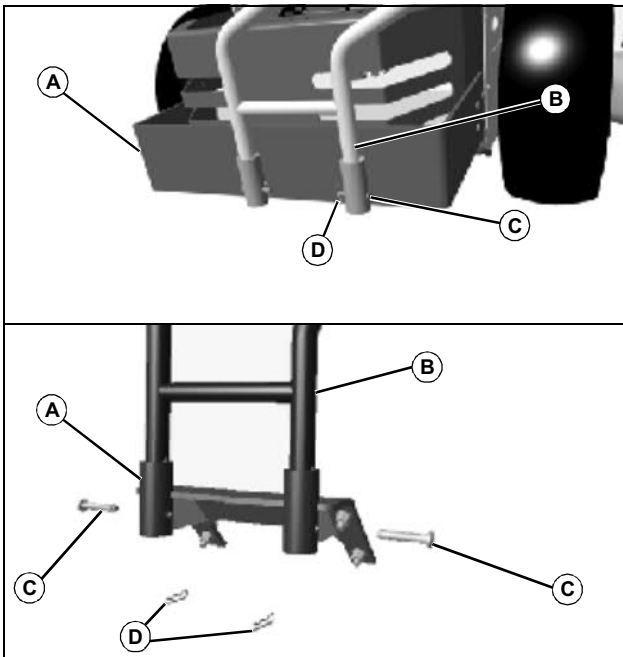

MX12489 MX12486

Picture Note: Upper picture shows 717/727 mounting bracket. Lower picture shows 737/757 mounting bracket.

2. Slide hopper H-frame (B) into support bracket (A).
3. Align holes in mounting bracket with holes in H-frame. Secure H-frame with drilled pins (C) and spring locking pins (D).

Installing Upper Chute

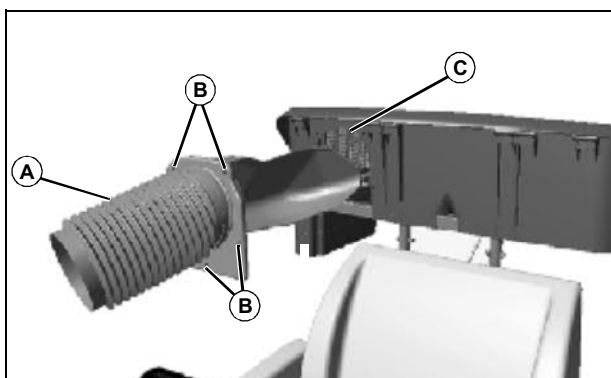

MX12484

1. Install upper chute (A) into opening (C) in hopper as shown.
2. Secure upper chute to hopper with screws at four points

- (B). Tighten all chute mounting hardware.

Installing Grass Bags



CAUTION: Avoid injury! Exhaust area is hot. Make sure exhaust deflector is installed at rear of machine before installing rear bagger grass bags.

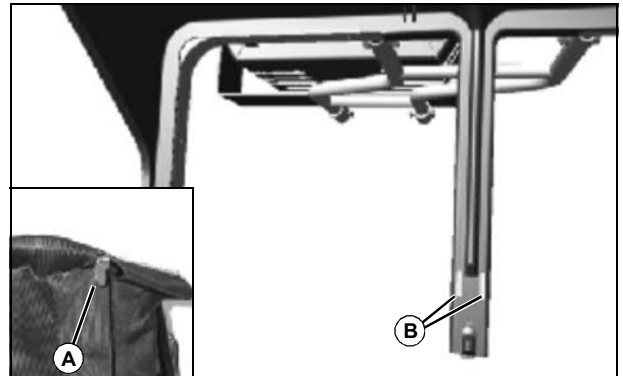

MX12480

1. Install grass bags to hopper frame by inserting clip (A) into hole (B) in center frame bag support.

Installing POWER FLOW

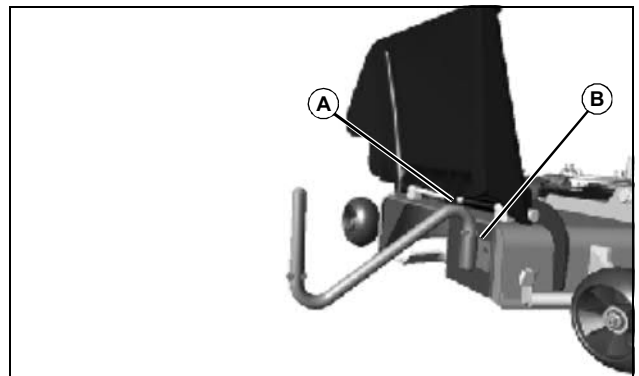

MX12482

1. Install short end (A) of long front support rod in front mounting bracket (B).

<https://www.ebooklibonline.com>

Hello dear friend!

Thank you very much for reading.

Enter the link into your browser.

The full manual is available for immediate download.

<https://www.ebooklibonline.com>