

**JOHN DEERE**  
**WORLDWIDE COMMERCIAL & CONSUMER**  
**EQUIPMENT DIVISION**

---

**Blower and Rear Bagger**  
**2 and 3 Bag Material Collection System**

SN (010001- )

OMTCU24344 K7

**OPERATOR'S MANUAL**



**JOHN DEERE**

All information, illustrations and specifications in this manual are based on the latest information at the time of publication. The right is reserved to make changes at any time without notice.

COPYRIGHT© 2007  
Deere & Co.

John Deere Worldwide Commercial and Consumer Equipment Division  
All rights reserved  
Previous Editions  
COPYRIGHT© 2006

North American Version  
Litho in U.S.A.

---

---

# INTRODUCTION

---

---

## Table of Contents

Introduction.....	1
Product Identification.....	1
Safety Labels.....	2
Safety.....	3
Preparing Vehicle.....	4
Assembly.....	9
Installing.....	18
Removing and Storing.....	21
Operating.....	23
Service Intervals.....	24
Service.....	24
Troubleshooting.....	28
Specifications.....	28
Getting Quality Service.....	28

---

---

## Introduction

### Using Your Operator's Manual

Read this entire operator's manual, especially the safety information, before operating.

This manual is an important part of your machine. Keep all manuals in a convenient location so they can be accessed easily.

Use the safety and operating information in the attachment operator's manual, along with the machine operator's manual, to operate and service the attachment safely and correctly.

If your attachment manual has a section called Preparing the Machine, it means that you will have to do something to your tractor or vehicle before you can install the attachment. The Assembly and Installation sections of this manual provide information to assemble and install the attachment to your tractor or vehicle. Use the Service section to make any needed adjustments and routine service to your attachment.

If you have any questions or concerns with the assembly, installation, or operation of this attachment, see your local John Deere dealer or call the John Deere Customer Contact Center at 1-800-537-8233 for assistance.

Warranty information on this John Deere attachment can be found in the warranty that came with your John Deere tractor or vehicle.

---

---

## Product Identification

### Product Compatibility

- The blower is compatible with all models.
- The 2 Bag Rear Bagger is compatible with the Z-Trak Estate models Z510A, Z520A, and the Z-Trak Pro series Z810A, Z820A, Z830A, Z840A, Z850A (any model up to a 54 inch mower deck).
- The 3 Bag Rear Bagger is compatible with the Z-Trak Pro series Z810A, Z820A, Z830A, Z840A, Z850A.

### Record Identification Numbers

#### Blower

Serial Number (010001- )

If you need to contact an Authorized Service Center for information on servicing, always provide the product model and serial number.

You will need to locate the serial number (A) for the attachment. Record the information in the spaces provided below.

# SAFETY LABELS



MX22809

DATE OF PURCHASE:

DEALER NAME:

DEALER PHONE:

PRODUCT SERIAL NUMBER (A):

## Safety Labels



### Understanding The Machine Safety Labels

The machine safety labels shown in this section are placed in important areas on your machine to draw attention to potential safety hazards.

On your machine safety labels, the words DANGER, WARNING, and CAUTION are used with this safety-alert symbol. DANGER identifies the most serious hazards.

The operator's manual also explains any potential safety hazards whenever necessary in special safety messages that are identified with the word, CAUTION, and the safety-alert symbol.

### WARNING



M118454

#### Rotating Blade -Thrown Objects

- Operate blower with entire grass catcher secured in place.

### DANGER

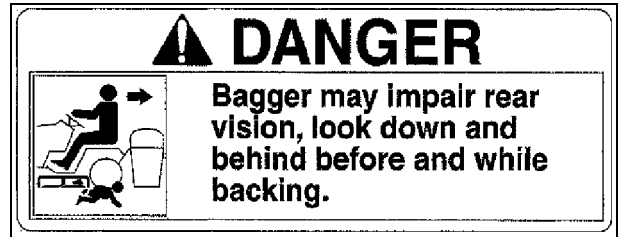

M146238

**Picture Note:** Located on front side of bagger hopper.

Bagger may impair rear vision, look down and behind before and while backing.

### WARNING



M151187

To avoid injury from thrown objects, keep bystanders away. Shut off engine before opening hopper top. Keep chutes in place. Never allow riders on hopper top or on frame.

### CAUTION

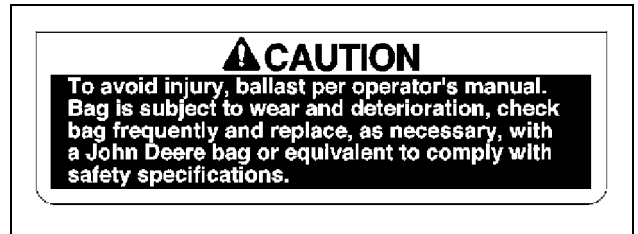

M151187

To avoid injury, ballast per operator's manual. Bag is subject to wear and deterioration, check bag frequently and replace, as necessary, with a John Deere bag or equivalent to comply with safety specifications.

### CAUTION

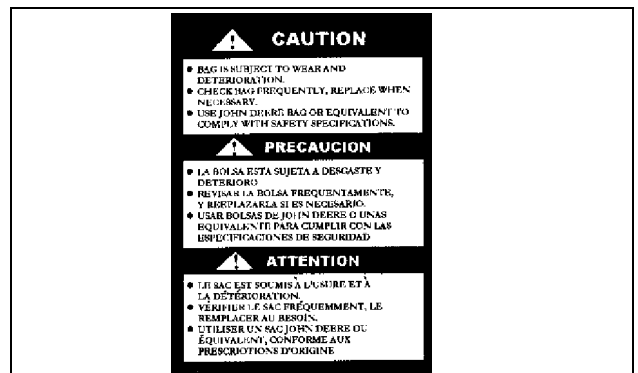

GC00215

- Bag is subject to wear and deterioration.

**<https://www.ebooklibonline.com>**

Hello dear friend!

Thank you very much for reading.

Enter the link into your browser.

The full manual is available for immediate download.

**<https://www.ebooklibonline.com>**

# SAFETY

---

- Check bag frequently and replace when necessary.
- Use John Deere bag or equivalent to comply with safety specifications.

---

## Safety

### Read Safety in Machine Operator's Manual

Read the general safety operating precautions in your machine operator's manual for additional safety information.

### Operating Safely

Read, understand and follow all instructions in this attachment manual, the machine operator's manual and safety signs on equipment before starting.

Use proper front ballast. Remove ballast when the material collection system is removed.

Hopper extends beyond machine. Be aware of surrounding objects when making short turns.

Do not operate material collection system unless entire grass catcher is fastened in place with hopper cover securely latched.

Do not let anyone ride on the mower or material collection system. Riders are subject to injury such as being struck by foreign objects or being thrown off. Riders may obstruct the operator's view and cause a collision.

#### Before bag removal or installation:

- Stop mower.
- Disengage mower or PTO.
- Stop engine and remove key.
- Wait for engine and all moving parts to stop before leaving the operator seat.

#### Before backing up machine:

- Stop machine.
- Look behind hopper for children.
- Keep bystanders away when unloading material collection system.

#### Operate safely on slopes:

- Empty bags when they are half full.
- Do not operate on steep slopes.
- Before turning, slow down.
- Avoid sudden starts and stops.
- Do not park machine with material collection system on slopes.

#### Bag Maintenance:

- Bag is subject to wear and deterioration.
- Check bag frequently; replace when necessary.
- Use John Deere bag or equivalent to comply with safety specifications.
- Do not leave clippings in bags overnight.

### Parking Safely

1. Stop machine on a level surface, not on a slope.
2. Disengage mower blades or any other attachments.
3. Lower attachments to the ground.
4. Lock the park brake.

5. Stop the engine.
6. Remove the key.
7. Wait for engine and all moving parts to stop before you leave the operator's seat.
8. Close fuel shut-off valve, if your machine is equipped.
9. Disconnect the negative battery cable or remove the spark plug wire(s) (for gasoline engines) before servicing the machine.

### Protect Children

- Tragic accidents can occur if the operator is not alert to the presence of children. Keep children indoors when the machine and attachment are operated and under the watchful care of another responsible adult.
- Never assume that children will remain where you last saw them. Stay alert to the presence of children. Turn the machine off if a child enters the work area.
- Do not let children or an untrained person operate the machine.
- Do not carry or let children ride on any attachment or machine even with the attachment off. Do not tow children in a cart or trailer.

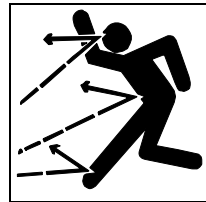

### Avoid Injury From Thrown Objects

- When operating the vehicle with the MCS attachment installed make sure all chutes and hoses are securely in place. Keep hopper closed or MCS in operating position.
- Stop the engine and wait for all moving parts to stop before removing or lifting any attachment components.

- Avoid injury from impeller blades and thrown objects. Remove attachment when operating vehicle in side discharge mode. Make sure deflector shield is in place on mower deck if attachment is removed.



### Avoid Injury From Rotating Blades

- Keep hands and feet away from rotating blades and blower assembly when engine is running.

- Stop engine and wait for moving parts to stop before servicing components.
- Do not operate MCS or blower unless all attachment components are in place and latched.

### Practice Safe Maintenance

- Only qualified, trained adults should service this machine.
- Understand service procedure before doing work. Keep area clean and dry.
- Do not operate the engine in a confined space where dangerous carbon monoxide fumes can collect.
- Never lubricate, service or adjust the machine or attachment while it is moving. Keep safety devices in place and in working condition. Keep hardware tight.
- Keep hands, feet, clothing, jewelry, and long hair away from any moving parts, to prevent them from getting caught.
- Lower any attachment completely to the ground or to an existing attachment mechanical stop before servicing the attachment. Disengage all power and stop the engine. Lock park brake and remove the key. Let machine cool.
- Disconnect battery or remove spark plug wire (for gasoline engines)

# PREPARING VEHICLE

before making any repairs.

- Before servicing machine or attachment, carefully release pressure from any components with stored energy, such as hydraulic components and springs.
- Release hydraulic pressure by lowering attachment or cutting units to the ground or to a mechanical stop and move hydraulic control levers.
- Securely support any machine or attachment elements that must be raised for service work. Use jack stands or lock service latches to support components when needed.
- Never run engine unless park brake is locked.
- Keep all parts in good condition and properly installed. Fix damage immediately. Replace worn or broken parts. Replace all worn or damaged safety and instruction decals.
- Check all hardware at frequent intervals to be sure the equipment is in safe working condition.
- Do not modify machine or safety devices. Unauthorized modifications to the machine or attachment may impair its function and safety.

## Preparing Vehicle

### Checking Tire Pressure

Check tire pressure of machine before installing bagger. See your machine operator's manual.

### Installing Proper Mower Blades

**IMPORTANT: Avoid damage! When replacing mower blades, always use genuine John Deere Service Parts.**

- For best performance, always use correct mower blade for job being performed.
- Always follow safety and service instructions in the machine operator's manual when changing mower blades.

For maximum performance from your material collection system (MCS), install the correct mower blades for your application:

- Mulching Blades - Not for use with MCS.
- Standard Blades - Standard blades are designed for bagging, side discharging, and all mowing conditions.

### Install Front and Rear Mounting Brackets for MCS Blower

#### MCS Blower Front Mounting Bracket

1. Park machine safely. (See Parking Safely in the SAFETY section.)

**CAUTION: Avoid injury! Rotating blades are dangerous. Before adjusting or servicing mower:**

- Disconnect spark plug wire(s) or battery negative (-) cable to prevent engine from starting accidentally.
- Always wear gloves when handling mower blades or working near blades.

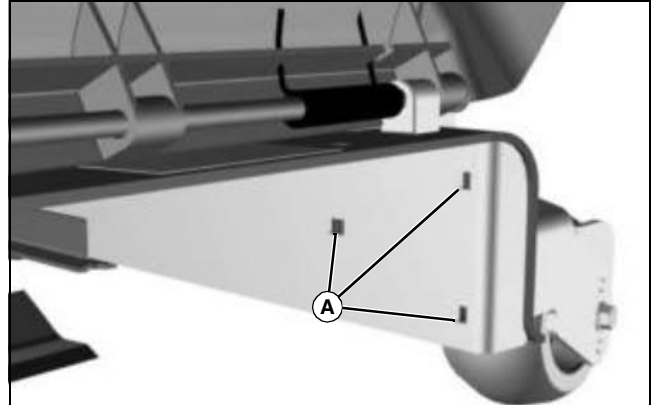

MX25142

2. Lift discharge chute up and locate mounting holes (A) for front bracket.

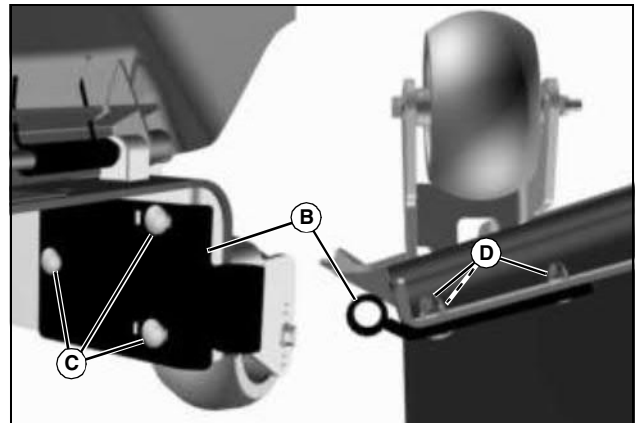

MX25141

3. Install bracket (B) with three M8x25 carriage bolts (C) and M8x10 flange nuts (D). Tighten all hardware.

# PREPARING VEHICLE

## MCS Blower Rear Mounting Bracket

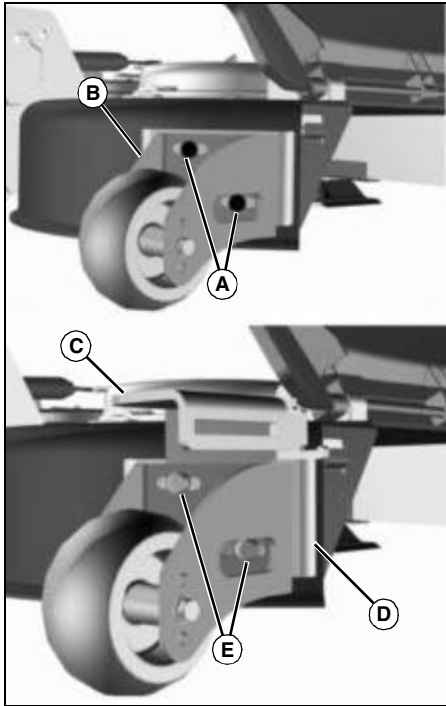

MX25140

1. Remove the two M8x20 self-tapping screws (A) and the anti-scalp wheel bracket (B) and anti-scalp wheel as an assembly.
2. Insert the MCS blower mount bracket (C) between the anti-scalp wheel bracket and the deck mounting bracket (D) and secure with two M8x30 hex head bolts (E). Tighten hardware.

## Install Pulley and Spacer

1. Remove belt shield on discharge chute side of mower deck.

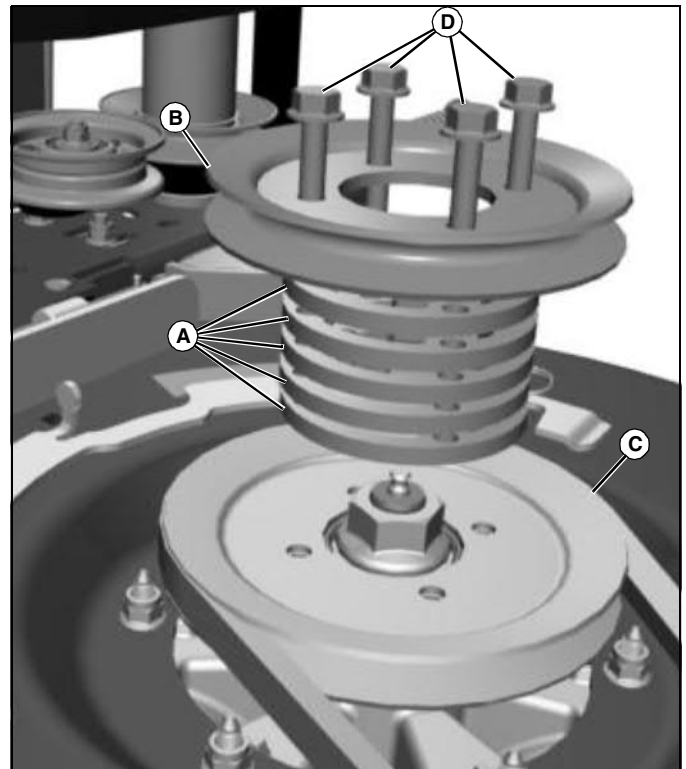

MX25080

**Picture Note:** Five spacers are installed for all decks except the 54 and 60 in. M-Series decks, which require seven spacers.

2. Install the appropriate number of spacers (A) and extra pulley (B) on sheave (C) using four M8x50 flange head bolts (D), and tighten to 24 N•m (18 lb-ft).

## Install New Gate (M-Series Mower Deck Only)

1. Park machine safely. (See Parking Safely in the SAFETY section.)



**CAUTION:** Avoid injury! Rotating blades are dangerous. Before adjusting or servicing mower:

- Disconnect spark plug wire(s) or battery negative (-) cable to prevent engine from starting accidentally.
- Always wear gloves when handling mower blades or working near blades.

2. Lift discharge chute up.

# PREPARING VEHICLE

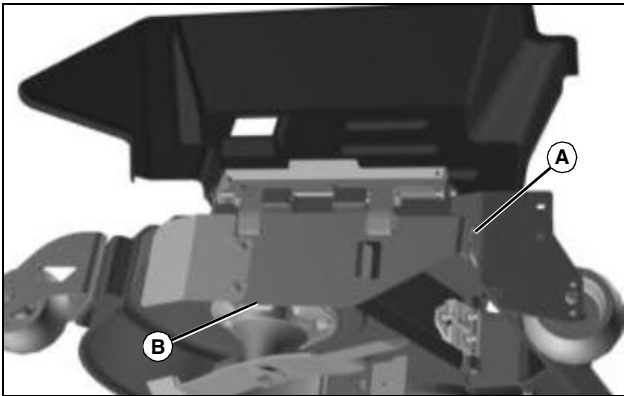

3. Remove link assembly (A).

**NOTE: Gate without extension is used when MCS is installed. Retain gate with extension in pocket on seat back. Gate extension must be installed if machine is operated without MCS blower.**

4. Remove discharge gate with rear extension (B).

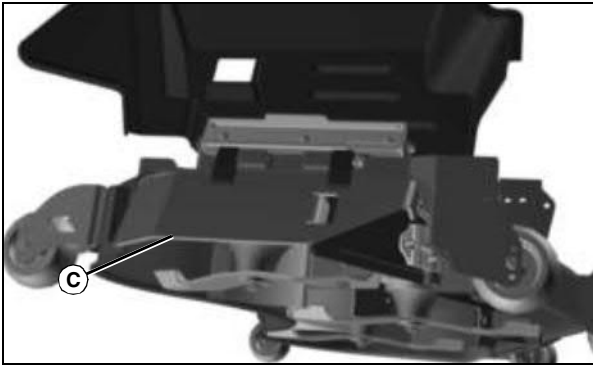

5. Install new gate (C) and attach link assembly.

## Install Mulch-On-Demand Position Lever (M-Series Mower Deck Only)

1. Park machine safely. (See Parking Safely in the SAFETY section.)

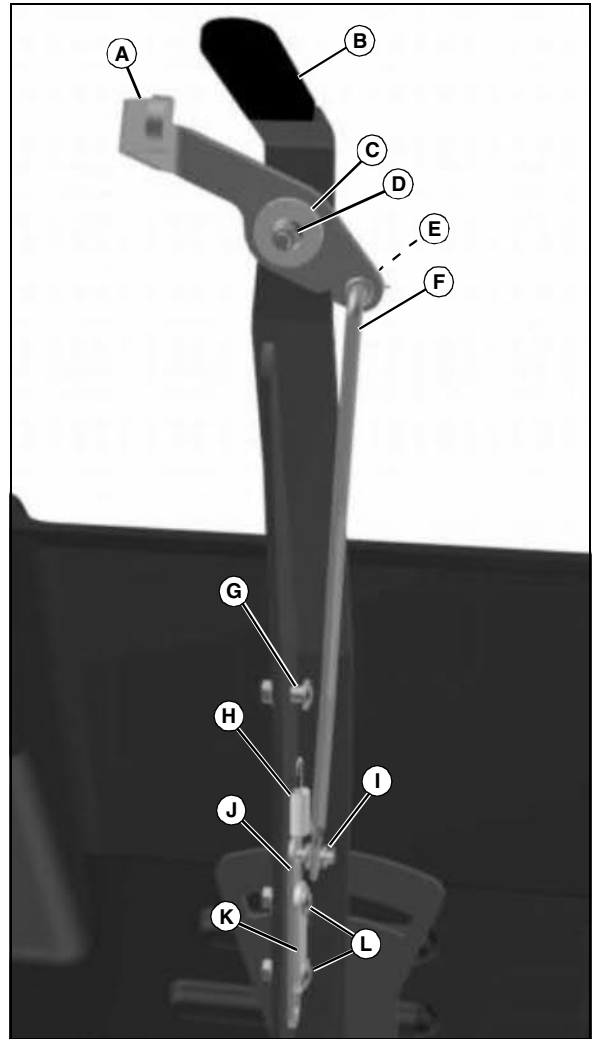

2. Insert bushing (C) into lever release (A) and attach to deck mode lever (B) with M6x30 cap screw and nut (D). Tighten hardware.

3. Position pawl plate (J) and shim latch (K) in place and secure with two M6x21 socket head shoulder bolts and nuts (L). Do not overtighten hardware.

4. Install M6x21 socket head shoulder bolt and nut (G). Tighten hardware.

5. Install tension spring (H) from pawl plate (J) to socket head shoulder bolt (G).

6. Install link latch (F) to lever release and pawl plate. Secure link latch with M8.4x1.6 washer and cotter pin (E) and M6.4x1.6 washer and cotter pin (I). Spread cotter pins to secure in place.

## Trim Discharge Chute (60 and 72 Inch Only)

# PREPARING VEHICLE

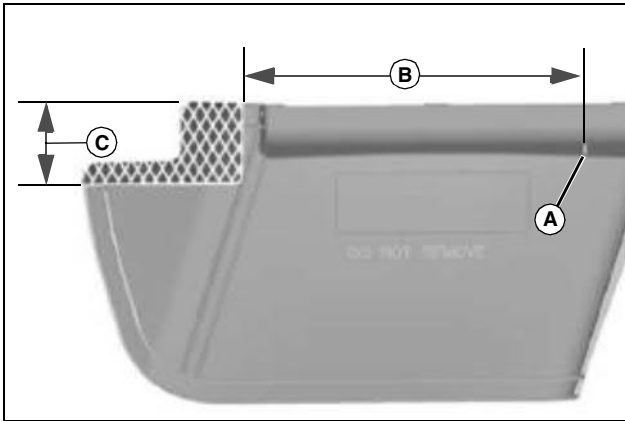

MX22932

1. Begin at point (A) and measure distance (B) as shown. Scribe a mark.
2. Measure distance (C) beginning from hinge side of guard as shown. Scribe a mark.
3. Extend lines from both marks so they meet at a 90° angle and identify the shaded area as shown.
4. Remove shaded area using a suitable cutting tool.

### Specifications

- Distance (B) ..... 423.00 ± 0.80 mm (16.65 ± 0.03 in.)  
 Distance (C) ..... 88.66 ± 0.80 mm (3.50 ± 0.03 in.)

### Installing Weight Bracket

1. Park machine safely.

**NOTE: Secure and support vehicle as required. Take all safety precautions.**

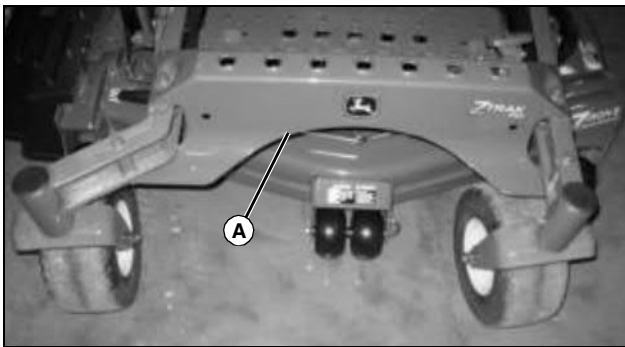

MX25036

2. Clean front cross member (A) area of any debris.
3. Center weight bracket on cross member.

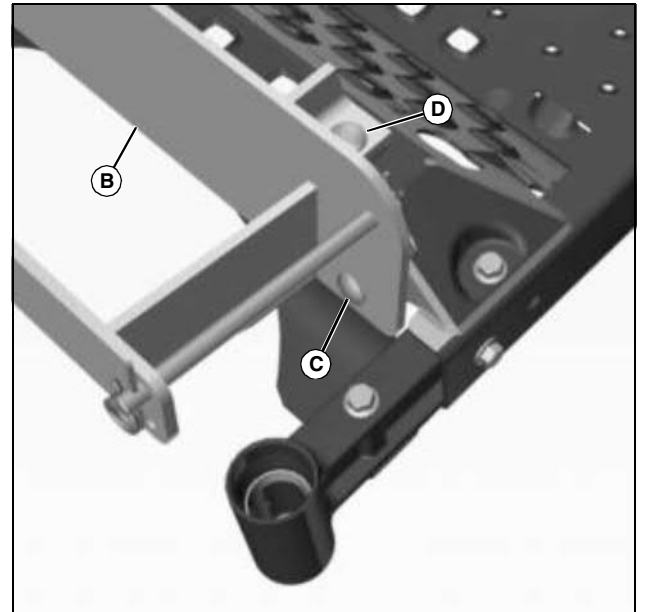

MX25037

**Picture Note: Front caster wheel not shown for photo clarity only.**

4. Align front mounting holes of the weight bracket (B) with the holes in the cross member.
5. Install M12x35 carriage bolts (C), washers, and nuts. Tighten all hardware.
6. Install M12x50 carriage bolts (D) through top of weight bracket.

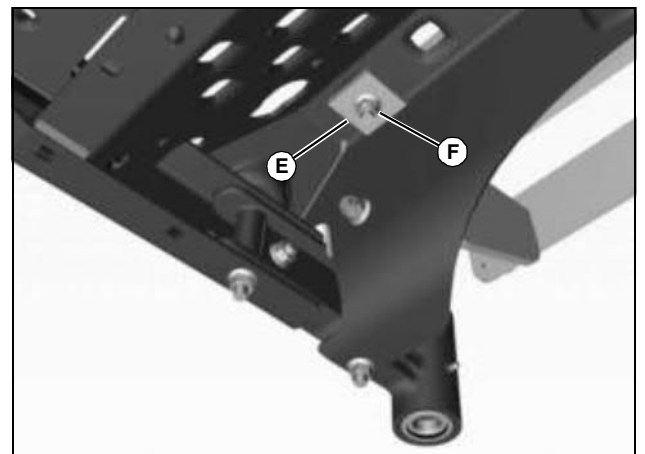

MX25038

7. Install backing plates (E) and nuts (F). Tighten all hardware.

### Installing Ballast



**CAUTION: Avoid injury! Machine can become unstable when operating with attachment. Ballast is required when the attachment is installed.**

**When the attachment is removed, also remove any ballast that was added to the machine.**

**Use only attachments and accessories recommended by the manufacturer.**

**NOTE: Ballast is not included with this kit but is required for safe**



**Suggest:**

**If the above button click is invalid.**

**Please download this document**

**first, and then click the above link**

**to download the complete manual.**

**Thank you so much for reading**

# PREPARING VEHICLE

operation. Refer to chart for specific requirements and see your authorized John Deere dealer for ordering.

## 2 Bag MCS KIT

Machine Model	Deck	Required Weights
Z510A	48"	1
Z520A	54"	1
Z520A	60"	1
Z810A	48"	0
Z810A	54"	0
Z820A	54"	0
Z820A	48"MOD	0
Z820A	54"MOD	0
Z820A	54	0

## 3Bag MCS KIT

Machine Model	Deck	Required Weights
Z820A	60"	4
Z820A	54"MOD	5
Z840A	54"	5
Z840A	60"	4
Z830A	60"	4
Z830A	60"MOD	4
Z830A	72"	2
Z850A	72"	2

Install the proper front ballast to help counterbalance the total weight of the bagger. Remove ballast when the bagger is removed. This will ensure proper operation of the machine when not bagging.

## Parts in Kit (Weight Bracket)

Qty.	Description
1	Bracket, Weight
2	Carriage Bolt, M12x35
2	Carriage Bolt, M12x50
4	Locknut, Flange

## Installing Weight

**NOTE:** See Ballast Chart for the proper weight requirements for your machine.

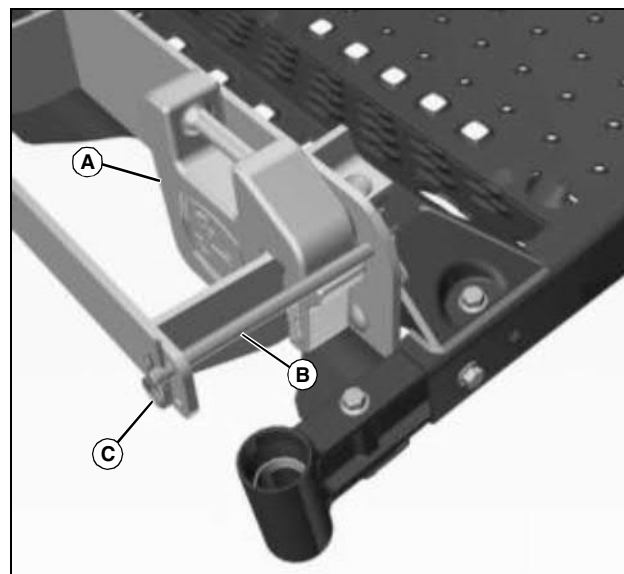

MX25039

1. Install suitcase weight(s) (A) onto bracket.
2. Slide the rod (B) over weight(s) to lock down.
3. Install locking pins (C) on rod.

## Ballast Chart

Model	Suitcase Weights
717A - 8 Bushel	N/A
727A - 8 Bushel	N/A
737A & 757A - 8 Bushel	2
737A & 757A - 14 Bushel	2
737B, 757B & 757MB - 8 Bushel	2
737B, 757B & 757MB - 14 Bushel	2
777B, 797B & 777MB - 14 Bushel	2
777C & 797C - 14 Bushel	2

**<https://www.ebooklibonline.com>**

Hello dear friend!

Thank you very much for reading.

Enter the link into your browser.

The full manual is available for immediate download.

**<https://www.ebooklibonline.com>**