

SERVICE MANUAL

EXCAVATOR
JS300, JS330, JS370

EN - 9813/7500 - ISSUE 2 - 10/2017

This manual contains original instructions, verified by the manufacturer (or their authorized representative).

Copyright 2017 © JCB SERVICE
All rights reserved. No part of this publication may be reproduced, stored in a retrieval system, or transmitted in any form or by any other means, electronic, mechanical, photocopying or otherwise, without prior permission from JCB SERVICE.

www.jcb.com

Foreword

The Operator's Manual

⚠
You and others can be killed or seriously injured if you operate or maintain the machine without first studying the Operator's Manual. You must understand and follow the instructions in the Operator's Manual. If you do not understand anything, ask your employer or JCB dealer to explain it.

Do not operate the machine without an Operator's Manual, or if there is anything on the machine you do not understand.

Treat the Operator's Manual as part of the machine. Keep it clean and in good condition. Replace the Operator's Manual immediately if it is lost, damaged or becomes unreadable.

Contents

01 - Machine

03 - Attachments, Couplings and Load Handling

06 - Body and Framework

09 - Operator Station

12 - Heating, Ventilating and Air-Conditioning (HVAC)

15 - Engine

18 - Fuel and Exhaust System

21 - Cooling System

27 - Driveline

30 - Hydraulic System

33 - Electrical System

72 - Fasteners and Fixings

75 - Consumable Products

78 - After Sales



00 - General

[Introduction](#) 15-49
[Operation](#) 15-50

Introduction

The crankcase ventilation filter is built into the underside of the rocker cover. The filter separates engine oil from the blow by gas. The engine oil drains back into the rocker arm housing.

No routine maintenance is required.

Operation

The engine oil is separated from the blow-by gas in the oil mist separator in two phases:

1. The blow-by gas is accelerated through the holes in the nozzle plate. This accelerated blow-by gas hits a wall in the oil mist separator housing central section and the engine oil droplets contained in the blow-by gas are separated. The vertical fins on the wall improve the separation of the engine

oil from the blow-by gases and also help engine oil to drain downwards. Once enough separated engine oil gets collected to open the check valve which is installed in the oil drainage duct the separated engine oil flows via the oil drainage duct back into the rocker arm housing. The check valve also prevents the blow-by gases in the rocker arm housing from entering the oil mist separator via the oil drainage duct.

Figure 129.

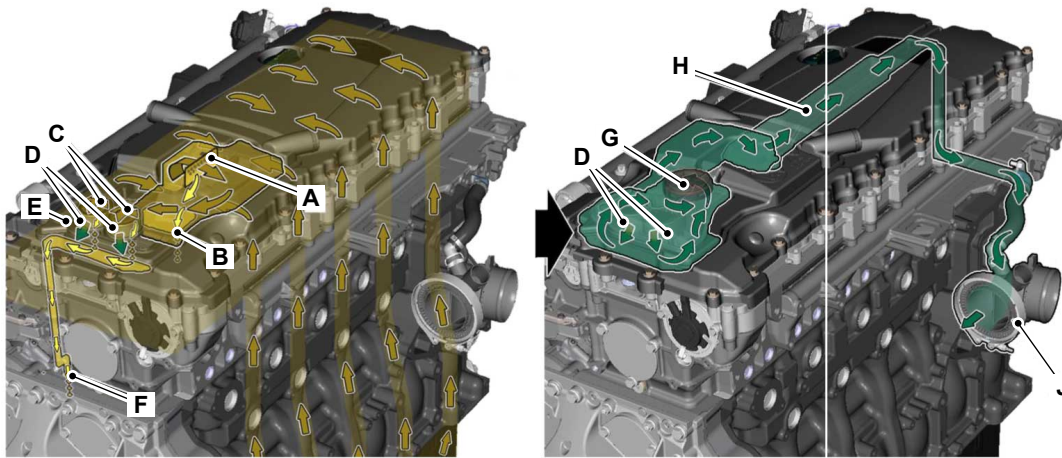

A Nozzle plate

C Impactors

E Oil drain valve

G Pressure regulating valve

J Air intake pipe

B Oil drain duct

D Fleece elements

F Crankcase ventilation non-return valve

H Vent line

2. The blow-by gas is accelerated through the holes in the nozzle plate. This accelerated blow-by gas hits a wall in the oil mist separator housing central section and the engine oil droplets contained in the blow-by gas are separated. The vertical fins on the wall improve the separation of the engine oil from the blow-by gases and also help engine oil to drain downwards. Once enough separated engine oil gets collected to open the check valve which is installed in the oil drainage duct the separated engine oil flows via the oil drainage duct back to the rocker arm housing. The check valve also prevents the blow-by gases in the rocker arm housing from entering the oil mist separator via the oil drainage duct.

<https://www.ebooklibonline.com>

Hello dear friend!

Thank you very much for reading.

Enter the link into your browser.

The full manual is available for immediate download.

<https://www.ebooklibonline.com>

00 - General

Adjust

Special Tools

Description	Part No.	Qty.
Crankshaft Turning Tool (123.5mm PCD)- MTU	334/V7497	1

1. Make the machine safe with the lift arm lowered.
 Refer to: PIL 01-03.

2. Make sure that the engine is safe to work on. If the engine has been running, make sure the engine has cooled sufficiently before you start the adjustment.

2.1. For accurate valve clearance measurement the engine must be cold. The engine must have been stopped for the minimum specified time period.

Duration: 30min

3. Open the engine cover.

Refer to: PIL 06-06-06.

4. Remove the rocker cover.

Refer to: PIL 15-42-06.

Figure 130.

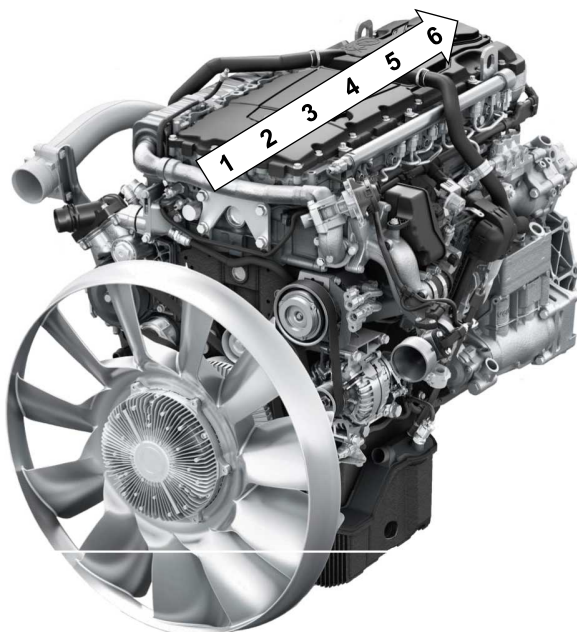

5. Check the TDC (Top Dead Centre) position of piston in cylinder 1. Refer to Figure 130.

5.1. If the rocker arms are unloaded on cylinder 1, the piston is at firing TDC.

5.2. If the rocker arms are under load on cylinder 1, the piston is at overlap TDC.

5.3. If necessary rotate the crankshaft with the recommended tool.

Special Tool: Crankshaft Turning Tool (123.5mm PCD)- MTU (Qty.: 1)

6. Make sure that the piston in cylinder 1 is at overlap TDC.

7. Measure the following valve clearances valves with the feeler gauge: Refer to Figure 131.

7.1. Exhaust valves on cylinder 2

7.2. Intake valves on cylinder 3

7.3. Exhaust valves on cylinder 4

7.4. Intake valves on cylinder 5

7.5. Intake valves, exhaust valves on cylinder 6

8. The engine brake valve clearance must be adjusted after checking or adjusting the exhaust valve clearances. 14

Figure 131. Valve clearance

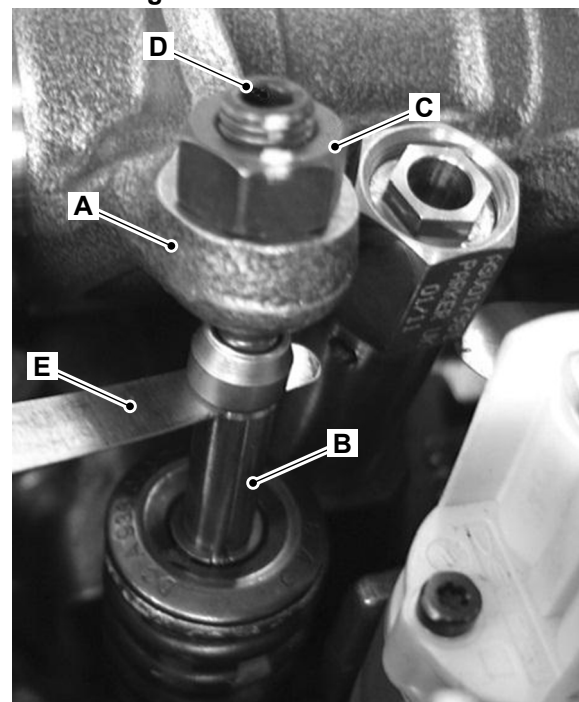

A Rocker arm

B Valve

C Locknut

D Adjusting screw 1

E Feeler gauge

9. Make sure that the piston in cylinder 6 is at overlap TDC.

10. Measure the valve clearances for the below mentioned valves with the feeler gauge: Refer to Figure 131.

- 10.1. Intake valves on cylinder 2.
 - 10.2. Exhaust valves on cylinder 3.
 - 10.3. Intake valves on cylinder 4.
 - 10.4. Exhaust valves on cylinder 5.
 - 10.5. Both intake and exhaust valves on cylinder 1.
11. The engine brake valve clearance must be adjusted after checking or adjusting the exhaust valve clearances. 14
 12. Make sure that the valve clearances on a cold engine are within specified limits.
 - 12.1. For intake valve
Distance: $0.3 \pm 0.05\text{mm}$
 - 12.2. For exhaust valve
Distance: $0.6 \pm 0.05\text{mm}$
 13. If the valve clearance is not within permitted limits, adjust the clearance as follows: Refer to Figure 131.
 - 13.1. Release the locknut 1 and turn out the adjusting screw 1 a few turns.
 - 13.2. Insert a feeler gauge between the valve and the rocker arm.
 - 13.3. Adjust the adjusting screw 1 again until the feeler gauge can just pass.
 - 13.4. Tighten the locknut 1 to the correct torque value.
 - 13.5. Measure the valve clearance again with the feeler gauge.
 14. Adjust the engine brake valve clearance after checking or adjusting the associated exhaust valve clearances. The engine brake valve clearance cannot be checked, it must be adjusted.

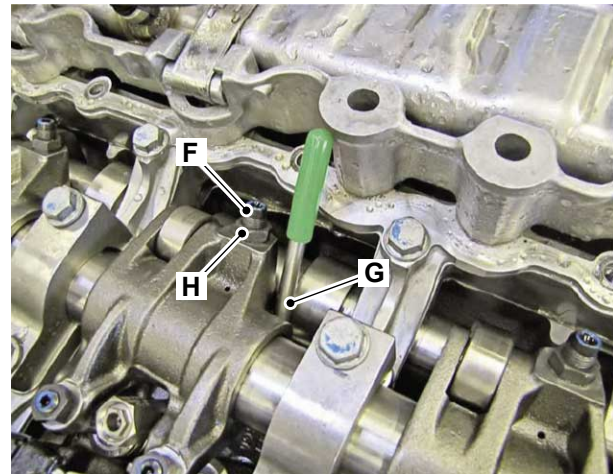
Figure 132. Engine brake valve clearance

- F** Adjusting screw 2
- G** Feeler gauge 0.5mm
- H** Locknut 2

- 14.1. Release the locknut 2 and turn out the adjusting screw 2 a few turns.
- 14.2. Insert the specified thickness feeler gauge between the engine brake valve and the rocker arm.
Length/Dimension/Distance: 0.5mm
- 14.3. Adjust the adjusting screw again until the feeler gauge can just pass.
- 14.4. Tighten the locknut 2 to the correct torque value.

Table 39. Torque Values

Item	Description	Nm
C	Locknut 1	30
H	Locknut 2	27



00 - General

[Introduction](#) 15-65
[Component Identification](#) 15-66

Introduction

The rocker assembly is an indirect valve actuating system consisting of rocker arms and a shaft.

The rocker arm is an oscillating lever that conveys radial movement from the cam lobe into linear movement at the poppet valve to open it. One end is raised and lowered by a rotating lobe of the camshaft via a tappet and push rod while the other end acts on the bridge piece which is connected to the valve stem.

Component Identification

Figure 133.

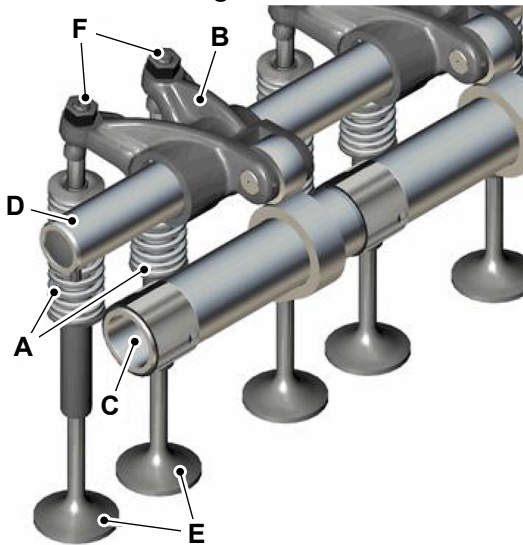

- A** Valve spring
- B** Intake rocker arm
- C** Intake camshaft
- D** Intake rocker arm spindle
- E** Intake valve
- F** Calibration elements for adjusting the valve clearance

Figure 134.

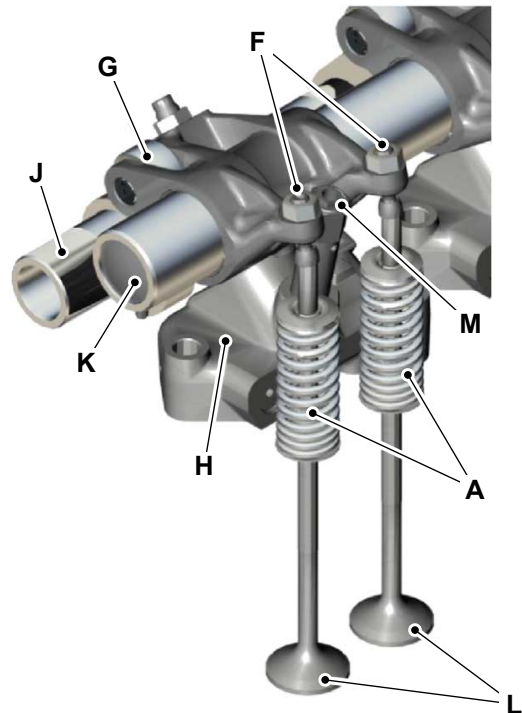

- A** Valve spring
- F** Calibration elements for adjusting the valve clearance
- G** Exhaust rocker arm
- H** hydraulic engine braking unit
- J** Exhaust camshaft
- K** Exhaust rocker arm spindle
- L** Exhaust valve
- M** Calibration element for pressure relief valve

Figure 135.

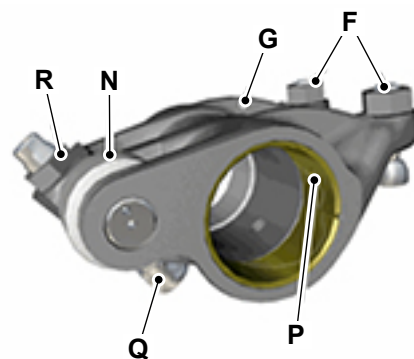

- F** Calibration elements for adjusting the valve clearance
- G** Exhaust rocker arm
- N** Rocker arm roller
- P** Oil access hole
- Q** Locator foot
- R** Calibration element for engine brake

06 - Rocker Cover

Remove and Install

Remove

1. Make the machine safe with the lift arm lowered. Refer to (PIL 01-03).
2. Make sure that the engine is safe to work on. If the engine has been running, make sure the engine has cooled sufficiently before you start the removal.
3. Remove the ignition key.
4. Clean the engine bay and the SCR (Selective Catalytic Reduction) unit to make sure no debris or dirt falls into the cylinder head after the rocker cover is removed.
5. Remove the screws (x 22) from the rocker cover.

Figure 136.

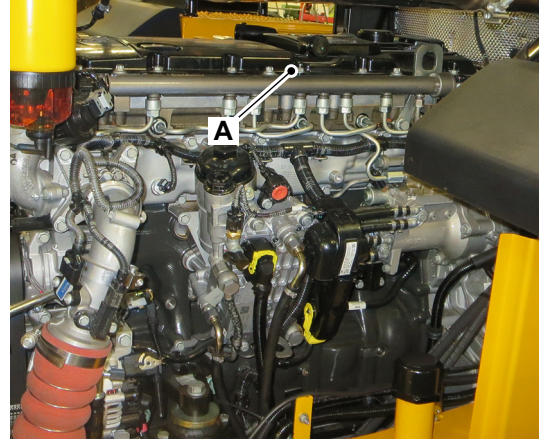

A Screws

6. Remove the rocker cover.
7. Discard the gasket if installed.

Install

1. The installation procedure is the opposite of the removal procedure.
2. Tighten the screws to the correct torque value in the given sequence. Refer to Figure 137.

Figure 137. Torque Tightening Sequence

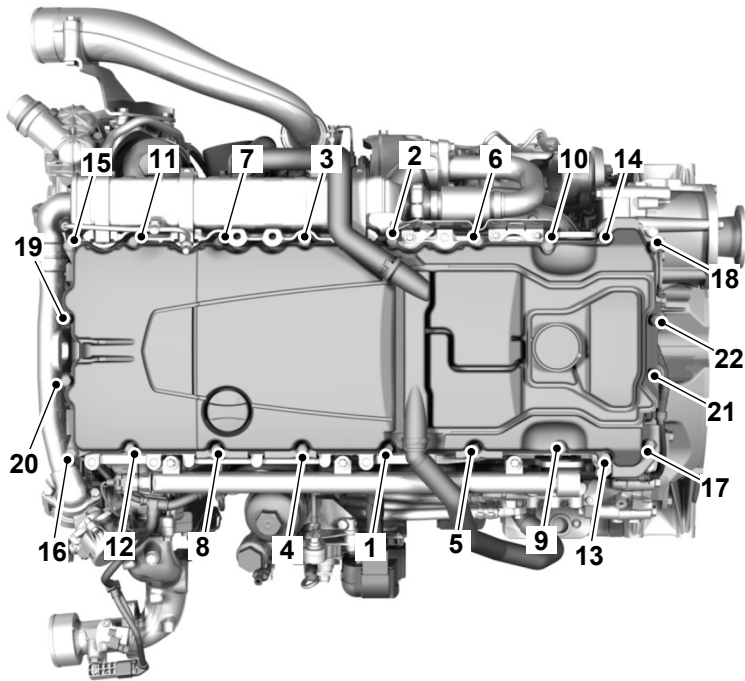

Table 40. Torque Values

Item	Description	Nm
A	Screws (For plastic rocker cover)	25
A	Screws (For light alloy rocker cover)	20

09 - Push Rod

Introduction

Push rods are used in a reciprocating engine to open and close the valves. They are moved by the cams on the camshaft. One end is pushed up by the cam and the other end makes contact with the rocker arms which rotates and pushes the valve open.

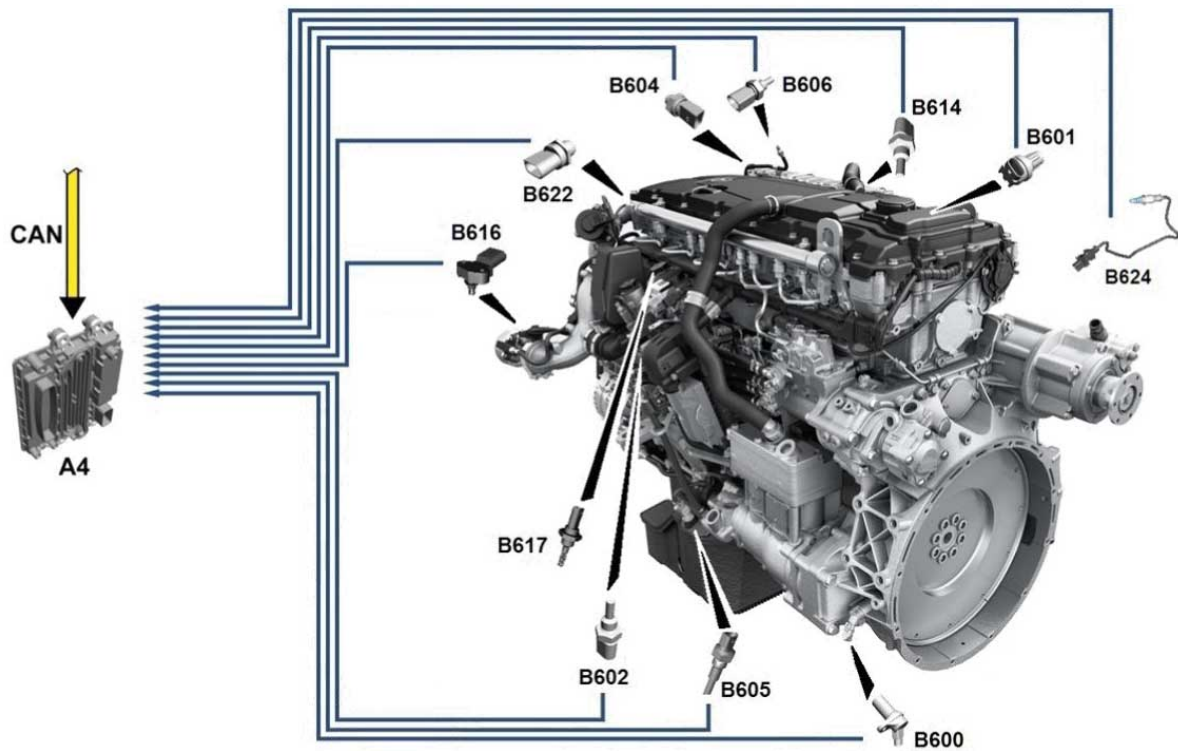
00 - General
Component Identification
Figure 152.

Table 45.

Item	Description
A4	ECM (Engine Control Module)
B600	Crankshaft position sensor
B601	Camshaft position sensor
B602	Fuel temperature sensor
B604	Oil pressure sensor
B605	Oil level / temperature sensor
B606	Coolant outlet temperature sensor
B614	Turbo outlet air temperature sensor
B616	TMAP (Temperature Manifold Air Pressure) sensor
B617	Charge air temperature sensor

Item	Description
B622	Fuel rail pressure sensor
B624	Lambda sensor (located in the exhaust outlet from the turbocharger)

03 - Crankshaft Position

Introduction 15-96
Operation 15-97

Introduction

The crankshaft position sensor is a device used to monitor the position or rotational speed of the crankshaft. This information is used by the ECM (Engine Control Module) to control the ignition system timing and other engine parameters.

Figure 153.

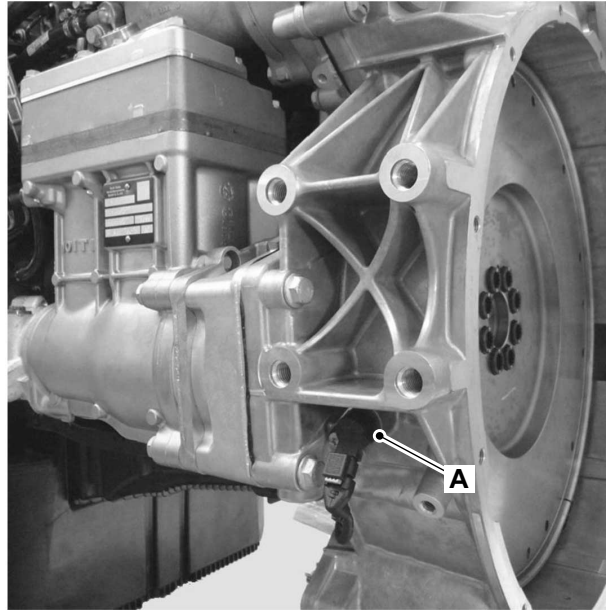

A Crankshaft position sensor

Operation

The crankshaft position sensor is an inductive sensor that has a sensor coil and a permanent magnet.

The permanent magnet of the crankshaft position sensor produces a magnetic field. The engine flywheel has bores arranged at a distance of 6° to each other with an exception of 18° gap. When the flywheel rotates, changes in the magnetic field generates the inductive voltage in the coil of the crankshaft position sensor. The ECM (Engine Control Module) uses these signals to determine the engine speed and the crankshaft angle with the help of the 18° gap.

06 - Camshaft Position

[Introduction](#) 15-98
[Operation](#) 15-99

Introduction

The camshaft position sensor is used to determine the compression stroke of the 1st cylinder. It sends the camshaft position electrical signals to ECM (Engine Control Module), so that the ECM knows which cylinder to inject the fuel into. If the crankshaft position sensor fails, the engine speed and the crankshaft position can also be determined from these signals.

Figure 154.

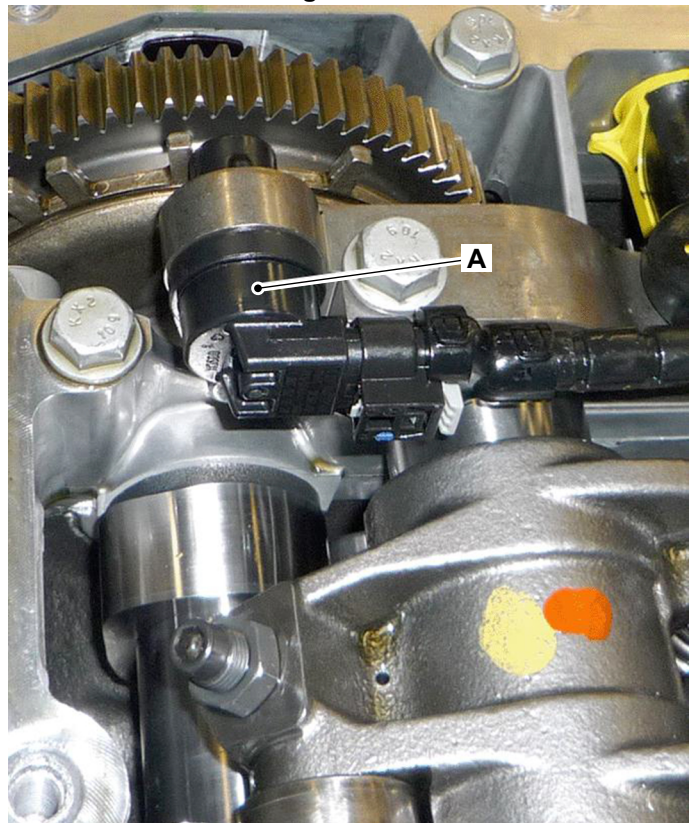

A Camshaft position sensor

Operation

The camshaft position sensor is a Hall effect sensor and has a permanent magnet and evaluation electronics.

The permanent magnet of the camshaft position sensor produces a magnetic field. As the camshaft rotates, the gaps in the pulse wheel result in changes to the magnetic field. The evaluation electronics of the camshaft position sensor transform these changes to the magnetic field into the switch signals and forward them to the ECM (Engine Control Module).

34 - Coolant Outlet Temperature

Introduction 15-100
Operation 15-101

Introduction

The ECM (Engine Control Module) uses the coolant outlet temperature sensor to detect the actual coolant temperature at the engine outlet. There is a negative temperature coefficient resistor inside the coolant outlet temperature sensor which senses the coolant outlet temperature.

Figure 155.

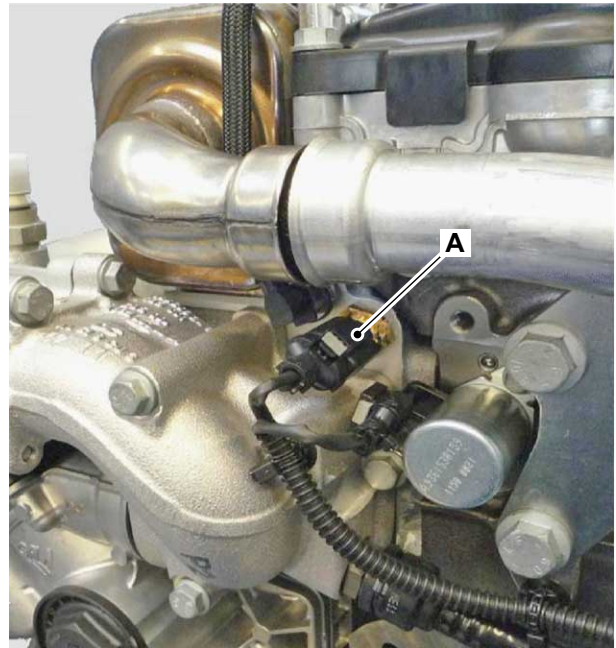

A Coolant outlet temperature sensor

Operation

Inside the coolant outlet temperature sensor there is a negative temperature coefficient resistor. For the negative temperature coefficient resistor, the electric resistance decreases as the temperature increases.

The temperature of the coolant in contact with the coolant outlet temperature sensor influences the temperature of the measuring probe inside the sensor and thus the magnitude of the electric resistance. The ECM (Engine Control Module) gives the related temperature based on the electric resistance.

35 - Ambient Air Temperature

Introduction

The ambient air temperature sensor is located close to the air filter intake inside the cooling compartment.

The sensor measures the air temperature at the engine air filter intake.

The signal from the sensor is connected to the engine interface ECU (Electronic Control Unit) and is part of the MTU engine installation. If faults are suspected contact a designated MTU dealer. Refer to: [PIL 15-00-00](#).

Figure 156.

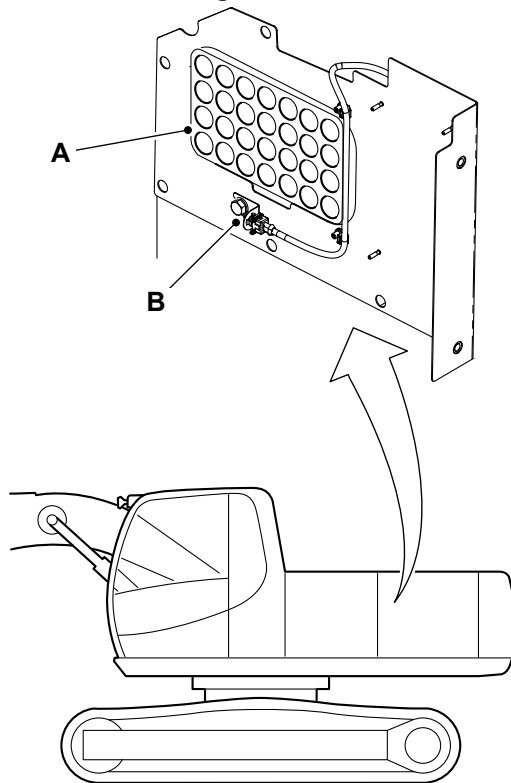

- A** Air filter intake
- B** Ambient air temperature sensor

37 - Turbo Outlet Air Temperature

Introduction 15-103
Operation 15-104

Introduction

The turbo outlet air temperature sensor (if installed) is also known as the compressor housing charge-air temperature sensor.

The sensor is located in the compressor outlet on the turbocharger. The ECM (Engine Control Module) uses the signal from the turbo outlet air temperature sensor to detect the air temperature at the compressor outlet of the turbocharger.

The ECM uses this information to find if the turbo outlet air actuator must be triggered, and if the injection must be adapted to protect the exhaust turbocharger from high thermal loads.

Figure 157.

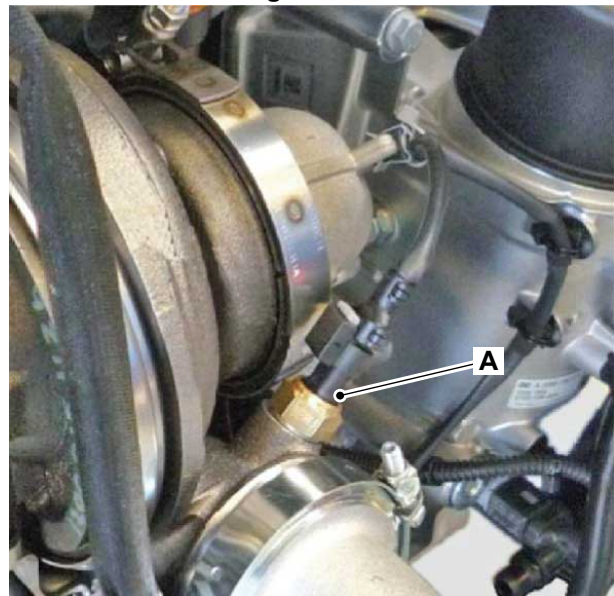

A Turbo outlet air temperature sensor

Operation

The turbo outlet air temperature sensor has a negative temperature coefficient resistor inside it. The electric resistance of the sensor decreases as the temperature increases. The ECM (Engine Control Module) finds the relevant temperature based on the electric resistance.

43 - Engine Oil Level

Introduction 15-105
Operation 15-106

Introduction

The engine oil level sensor measures the level of the engine oil in the oil sump. A pre-resistor and a resistor wire are connected in parallel and a negative temperature coefficient resistor is connected in series inside the engine oil level sensor. The resistor wire is located in the measuring probe. The measuring probe will be put fully into the engine oil if the engine oil level is correct.

Figure 158.

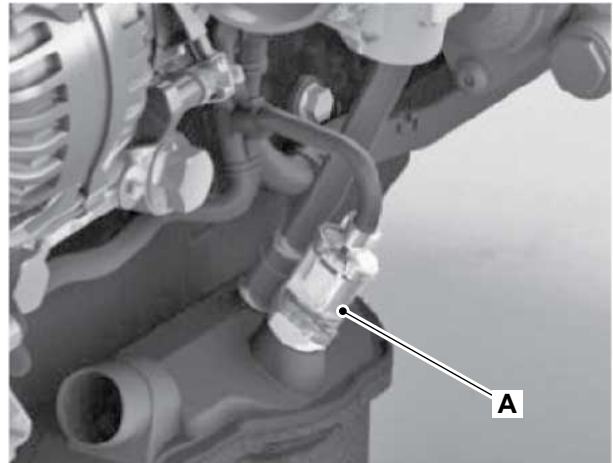

A Engine oil level sensor

Operation

The measuring probe of the engine oil level sensor is positioned fully into the engine oil if the oil level is correct.

The engine oil enters the measuring probe of the engine oil level sensor through a supply bore and touches the resistor wire. The total resistance at the engine oil level sensor changes as the resistor wire is immersed more or less in the engine oil. As the engine oil level decreases, the total resistance also decreases. As the engine oil level increases, the total resistance also increases.

When the ignition is switched on, the ECM (Engine Control Module) supplies a measuring voltage to the engine oil level sensor every 6s. It checks the total resistance of the engine oil level sensor and finds the current engine oil level in the oil sump.

The engine oil level must be checked in the normal way at the specified maintenance intervals. [Refer to: PIL 15-21-00.](#)

54 - Lambda

Introduction	15-107
Operation	15-108

Introduction

The lambda sensor is also called a wideband zirconia sensor. It is connected to the ECM (Engine Control Module). It is controlled by a separate micro-controller. The micro-controller controls the heater, the pump cell and the reference cell. It also monitors the operating temperature and the sensor findings. The measuring current is from 0 to 4 mA.

Figure 159.





Suggest:

If the above button click is invalid.

Please download this document

first, and then click the above link

to download the complete manual.

Thank you so much for reading

Operation

The lambda sensor is calibrated through a balancing resistor integrated into the connector. During operation, the lambda sensor is re-calibrated in regular intervals during coasting.

The lambda sensor has a ceramic element coated with platinum which acts as electrodes carrying a sensor signal to the wires when it contacts the exhaust gases. At high temperatures, the zirconia element causes the transfer of oxygen ions which creates a voltage. If the difference of oxygen concentration in the exhaust gas and the ambient air is more, higher voltage is produced. This voltage difference helps the air-fuel mixture and the engine emission to be kept within the required limit.

<https://www.ebooklibonline.com>

Hello dear friend!

Thank you very much for reading.

Enter the link into your browser.

The full manual is available for immediate download.

<https://www.ebooklibonline.com>