

SERVICE MANUAL

LOADALL (ROUGH TERRAIN
VARIABLE REACH TRUCK)
531-70, 535-95, 541-70

EN - 9813/9050 - ISSUE 1 - 01/2018

This manual contains original instructions, verified by the manufacturer (or their authorized representative).

Copyright 2017 © JCB SERVICE
All rights reserved. No part of this publication may be reproduced, stored in a retrieval system, or transmitted in any form or by any other means, electronic, mechanical, photocopying or otherwise, without prior permission from JCB SERVICE.

www.jcb.com

Foreword

The Operator's Manual

⚠
You and others can be killed or seriously injured if you operate or maintain the machine without first studying the Operator's Manual. You must understand and follow the instructions in the Operator's Manual. If you do not understand anything, ask your employer or JCB dealer to explain it.

Do not operate the machine without an Operator's Manual, or if there is anything on the machine you do not understand.

Treat the Operator's Manual as part of the machine. Keep it clean and in good condition. Replace the Operator's Manual immediately if it is lost, damaged or becomes unreadable.

Contents

01 - Machine

03 - Attachments, Couplings and Load Handling

06 - Body and Framework

09 - Operator Station

12 - Heating, Ventilating and Air-Conditioning (HVAC)

15 - Engine

18 - Fuel and Exhaust System

21 - Cooling System

24 - Brake System

25 - Steering System

27 - Driveline

30 - Hydraulic System

33 - Electrical System

72 - Fasteners and Fixings

75 - Consumable Products

78 - After Sales

Drain and Fill

Refer to: PIL 15-21-00.

Clean

▲ Notice: Clean the engine before you start engine maintenance. Obey the correct procedures. Contamination of the fuel system will cause damage and possible failure of the engine.

Notice: The engine and other components could be damaged by high pressure washing systems. Special precautions must be taken if the machine is to be washed using a high pressure system.

Make sure that the alternator, starter motor and any other electrical components are shielded and not directly cleaned by the high pressure cleaning system. Do not aim the water jet directly at bearings, oil seals or the engine air induction system.

Before carrying out any service procedures that require components to be removed, the engine must be properly cleaned.

Cleaning must be carried out either in the area of components to be removed or, in the case of major work, or work on the fuel system, the whole engine and surrounding machine must be cleaned.

Stop the engine and allow it to cool for at least one hour. DO NOT attempt to clean any part of the engine while it is running.

1. Make sure that the electrical system is isolated.
2. Make sure that all electrical connectors are correctly coupled. If connectors are open fit the correct caps or seal with water proof tape.
3. Cover the alternator with a plastic bag to prevent water ingress.
4. Seal the engine air intake, exhaust and breather system.
5. Make sure that the oil filler caps and dipstick are correctly installed.
6. Use a low pressure water jet and soft bristle brush to soak off caked mud or dirt.
7. Apply an approved cleaning and degreasing agent with a brush. Obey the manufacturers instructions.
8. Use a pressure washer to remove the soft dirt and oil. Important: DO NOT aim the water jet directly at oil seals or electrical connectors and electronic components such as ECU (Electronic Control Unit)'s, alternator or fuel injectors. DO NOT place the jet nozzle closer than the specified distance to any part of the engine or exhaust system.

Length/Dimension/Distance: 600mm

9. When the pressure washing is complete move the machine away from the wash area, or alternatively, clean away the material washed from the machine.
10. Before working on specific areas of the engine use a compressed air jet to dry off any moisture. When the area is dry use a soft clean brush to remove any sand or grit particles that remain.
11. When removing components be aware of any dirt or debris that may be exposed. Cover any open ports and clean away the deposits before proceeding.

Additional cleaning must be carried out prior to working on the high pressure fuel system. [Refer to: PIL 18-00-00.](#)

Check (Condition)

Start the engine and check for:

- Excessive smoke
- Excessive vibration
- Excessive noise
- Overheating
- Performance
- Unusual smells.

<https://www.ebooklibonline.com>

Hello dear friend!

Thank you very much for reading.

Enter the link into your browser.

The full manual is available for immediate download.

<https://www.ebooklibonline.com>

Check (Leaks)

Before you start the machine, do a check for oil leaks:

1. Make the machine safe.
2. Get access to the engine compartment (if applicable)
3. Check the engine and the area below for oil leaks.
4. Close the engine cover (if applicable).
5. If necessary, contact your JCB dealer.

Check (Pressure)

Special Tools

Description	Part No.	Qty.
Pressure Gauge (0-70 Bar)	892/00346	1

This test is used to diagnose suspected poor compression in one or more of the engine cylinders. Use ServiceMaster to control the test.

Engine Oil Pressure

Use the following procedures to measure the engine oil pressure. Several factors can influence the engine oil pressure, the following conditions are assumed:

- The correct engine oil has been used. [Refer to: PIL 15-21-00.](#)
- The engine oil level is correct. [Refer to: PIL 75-03-03.](#)

1. Make sure that the engine is safe to work on. If the engine has been running, let it cool before you start the service work.
2. Get access to the engine.
3. Disconnect the electrical connector to the oil pressure switch, remove the switch from the oil cooler housing.
4. Install a suitable adaptor into the vacant pressure switch port (M10 x 1.5mm thread) and a pressure test gauge. Make sure that the gauge has a sealing washer as shown.

[Special Tool: Pressure Gauge \(0-70 Bar\) \(Qty.: 1\)](#)

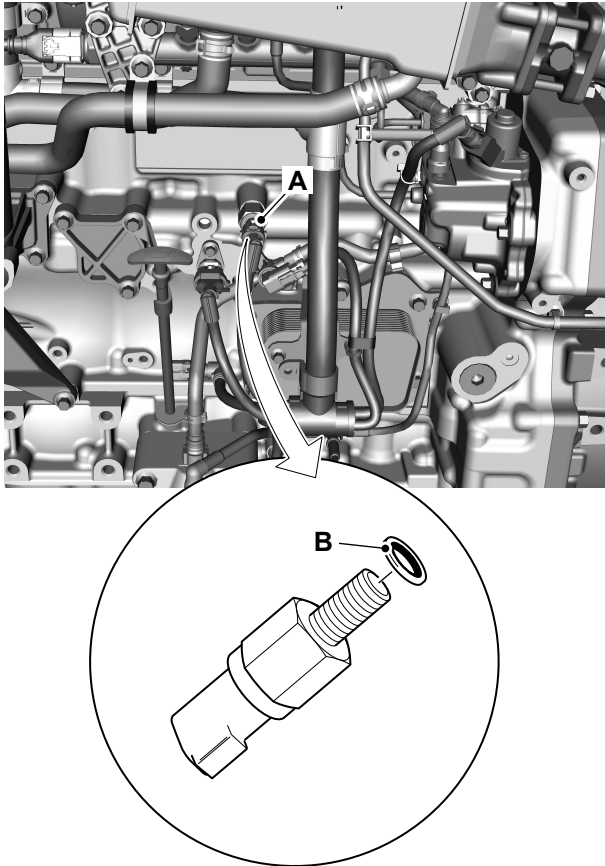
Figure 133.

A Oil pressure switch

B Sealing washer

5. Start the engine and allow a few seconds to gain oil pressure, increase the engine revs to the rated speed. Record the pressure gauge reading. Check that the pressure is within the specified tolerance.

Refer to: [PIL 15-00-00](#).

6. Remove the pressure gauge and install the pressure switch.

High Lubrication Oil Pressure

High oil pressure will be evident when starting in cold conditions. Typically the pressure will be 1 to 2 bar and higher in cold operation, the pressure should drop when the engine reaches normal operating temperature.

If the pressure remains high when operating temperature is achieved, check the oil level, if this is correct, suspect the oil pressure relief valve is at fault.

Low Lubrication Oil Pressure

Several factors can be the cause of low lubricating oil pressure:

- Low oil level - typically evident as a loss of pressure when operating on uneven ground or on a gradient.
- Blocked oil filter - a blocked filter will show as a gradual loss of pressure.
- Blocked suction strainer (pick-up pipe) - typically evident as low pressure on start up, if the blockage frees itself in the sump, the pressure will pick up to normal.
- Coolant in the oil - coolant in the lubricating oil will show as a milky discolouration of the oil and an increase in oil level. Check for damaged core plugs, lubricating oil cooler, cylinder head and/or gasket.
- Fuel in the oil - fuel in the lubricating oil, the oil will also have a diesel fuel smell. Check the fuel injection pump (FIP) shaft seal, piston ring wear, lift pump diaphragm damage or injector leakage if fuel is evident in the oil.
- Damaged oil pump - oil pressure will be high at low oil temperature but fall when oil becomes hotter.

Remove and Install

Special Tools

Description	Part No.	Qty.
Fuel Injector equipment Cap Kit (430 Engine)	320/B9321	1
Lifting Brackets (430 Engine)	320/B9421	1
Engine Lifting Spreader Bar	892/01382	1

Lifting Equipment

You can be injured if you use incorrect or faulty lifting equipment. You must identify the weight of the item to be lifted then choose lifting equipment that is strong enough and suitable for the job. Make sure that lifting equipment is in good condition and complies with all local regulations.

The lifting equipment used must be an approved type and capable of lifting the engine safely. The recommended lifting equipment is shown. Use a spreader bar when lifting the engine. Never attempt to manually lift heavy components on your own. Always use lifting equipment, or obtain the help of an assistant. Inspect the lifting brackets for signs of damage. The brackets must be correctly torqued to the crankcase. Make sure the lifting equipment does not damage any of the engine dressing and the rocker cover.

Component Identification

The following component identification is for a typical engine installation. There will be some component differences depending on the machine variant. Before attempting to remove the engine ensure that all the necessary components have either been removed, or safely disconnected from the engine.

Figure 134.

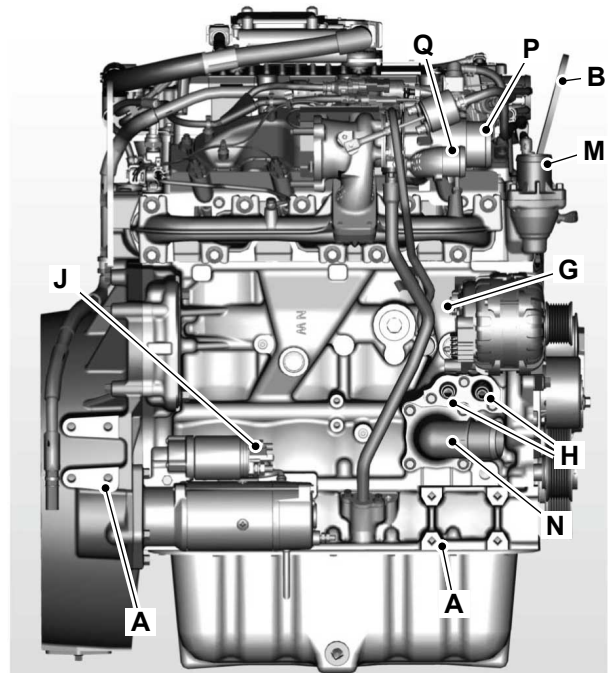

Figure 135.

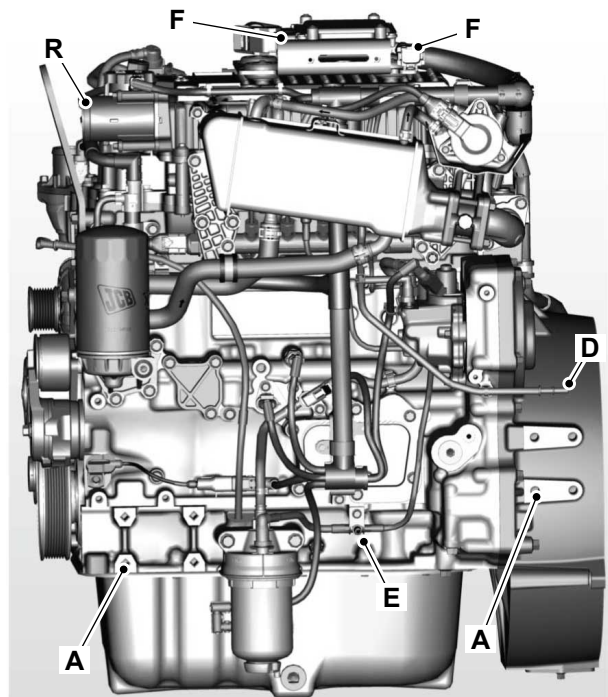
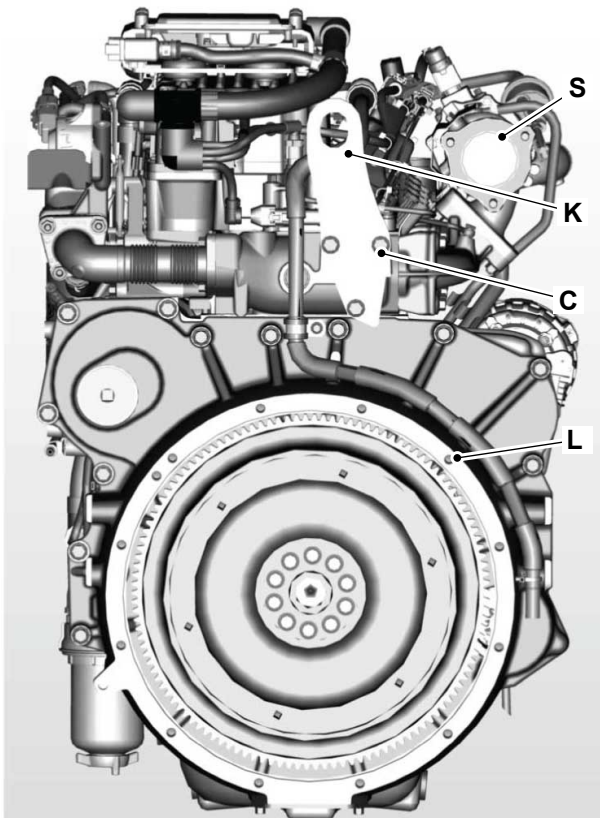

Figure 136.

- A** Engine mounting bolts
- B** Front lifting bracket - front
- C** Lifting bracket fixing bolts
- D** Fuel pipe - return to tank
- E** Fuel pipe - feed from lift pump
- F** Electrical connector - ECM (Engine Control Module)
- G** Electrical connections - alternator
- H** Hose connection - cab heater
- J** Electrical connections - starter motor
- K** Rear lifting bracket
- L** Gearbox/hydraulic pump to engine mounting bolts
- M** Top coolant hose
- N** Bottom coolant hose
- P** Air inlet hose
- Q** Turbocharger outlet hose
- R** Charge air inlet hose
- S** Exhaust pipe

Before Removal

1. Make sure that the engine is safe to work on. If the engine has been running, let it cool before you start the service work.
2. Position the machine on firm level ground. Make the machine safe.
[Refer to: PIL 01-03.](#)
3. Discharge the hydraulic pressure.

4. Get access to the engine.

Remove

1. Disconnect and remove the battery.
2. Drain the engine oil.
[Refer to: PIL 15-21-00.](#)
3. Drain the engine coolant.
[Refer to: PIL 21-00-00.](#)
4. Remove the cooling pack.
5. Disconnect the air inlet hose.
6. Disconnect the turbocharger outlet hose.
7. Disconnect the charge air hose.
8. Disconnect the exhaust system.
9. Label the cab heater hoses at the engine block connectors. Release the hose clips and disconnect the hoses.
10. Disconnect the top coolant hose.
11. Disconnect the bottom coolant hose.
12. Disconnect the wiring connections from the starter motor.
[Refer to: PIL 15-75-00.](#)
13. Disconnect the wiring connections from the alternator.
[Refer to: PIL 15-72-00.](#)
14. Disconnect the fuel supply and return pipes. Plug all the open ports and hoses to prevent contamination.
[Special Tool: Fuel Injector equipment Cap Kit \(430 Engine\) \(Qty.: 1\)](#)
15. Disconnect the electrical harness at the ECM machine side connector. Important: Do not touch the connector pins on the ECM or harness connectors. Cover the connectors to prevent contamination.
16. Make sure that all relevant harnesses and hoses are unclipped from the engine and tied out of the way.
17. If necessary, drain the hydraulic tank. Disconnect and plug the hydraulic suction and delivery lines at the transmission pump and gear pump. Label the hoses to aid installation.
18. Remove the gearbox/hydraulic pump to engine retaining bolts and pull the gearbox/hydraulic pump clear of the engine.

18.1. Make sure that the torque converter stays mounted on the gearbox shaft.

19. Attach slings to the engine lifting eyes.

Special Tool: Lifting Brackets (430 Engine) (Qty.: 1)

Special Tool: Engine Lifting Spreader Bar (Qty.: 1)

20. Take the weight of the engine on the hoist and remove the engine mounting bolts.

21. Raise the engine and lift it clear of the machine.

22. Lower the engine into a suitable stand that is capable of supporting the weight of the engine.

Figure 137.

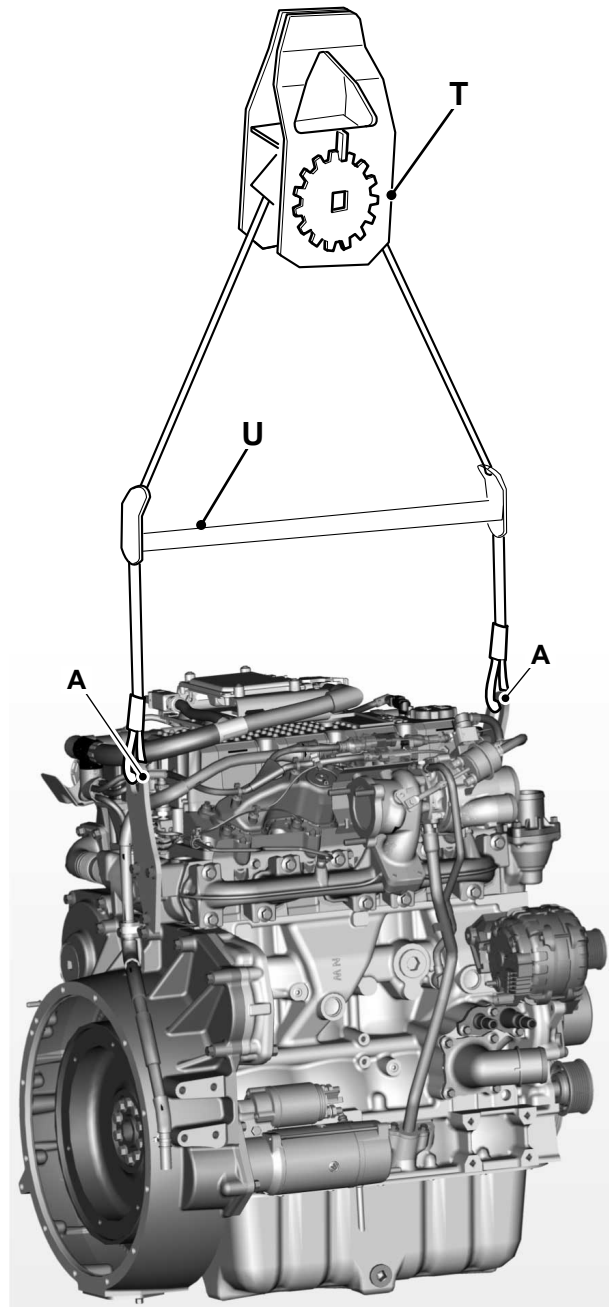

- A** Lifting brackets
- T** Lifting equipment
- U** Spreader bar

Install

1. The installation procedure is the opposite of the removal procedure. Additionally do the following step.
2. It is vitally important that the torque converter is installed at the gearbox and engine flywheel correctly. Failure to locate the torque converter correctly will result in damage to the gearbox oil pump on engine start up.

3. Fill the cooling system.

[Refer to: PIL 21-00-00.](#)

- 3.1. When you fill the cooling system make sure you use the correct water/antifreeze mixture. A 50% mixture should be maintained even if frost protection is not required.

[Refer to: PIL 75-09-03.](#)

4. Fill and check the hydraulic fluid level.
5. Fill and check the engine oil level. Make sure the correct oil is used.
[Refer to: PIL 75-03-03.](#)
6. Check the hydraulic, fuel and cooling systems for leaks.
7. Check the operation of all drive and hydraulic services.

Store and Recommission

Engines should be stored in the original shipping packaging. Damaged or disturbed packaging should be made weatherproof immediately.

If an engine is shipped with oil, it should be stored in the correct (upright) position.

If an engine is shipped dry of oil, after 6 months it should be filled with oil to the correct level and re-inhibited, refer to hot test description.

All floor stock engines should be stored under cover in dry conditions and not subjected to extreme variations in temperature or humidity.

If an engine is to be placed into storage, all external signs of surface coating damage or corrosion should be cleaned and re-coated. Electrical connectors and components should be coated with a protective spray.

Capping Engine Openings

All openings on the engine must be suitably capped to prevent ingress of water and contamination by foreign particles.

Figure 138.

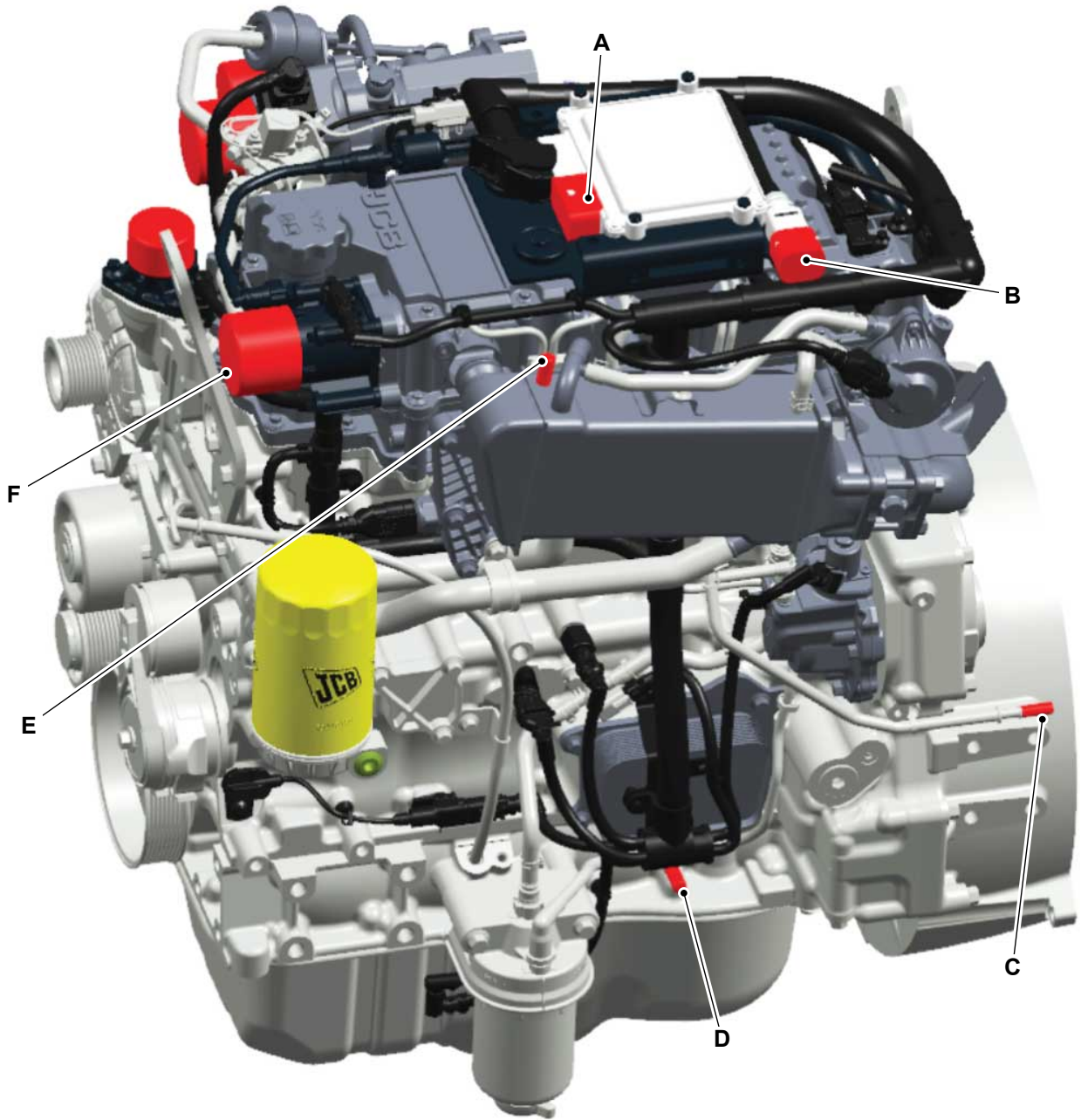

A ECM (Engine Control Module) machine harness connector cap

C Fuel pipe – return to tank cap

E Coolant circuit bleed pipe cap

B Machine harness interconnect connector cap

D Fuel pipe – feed from lift pump cap

F Air intake cap

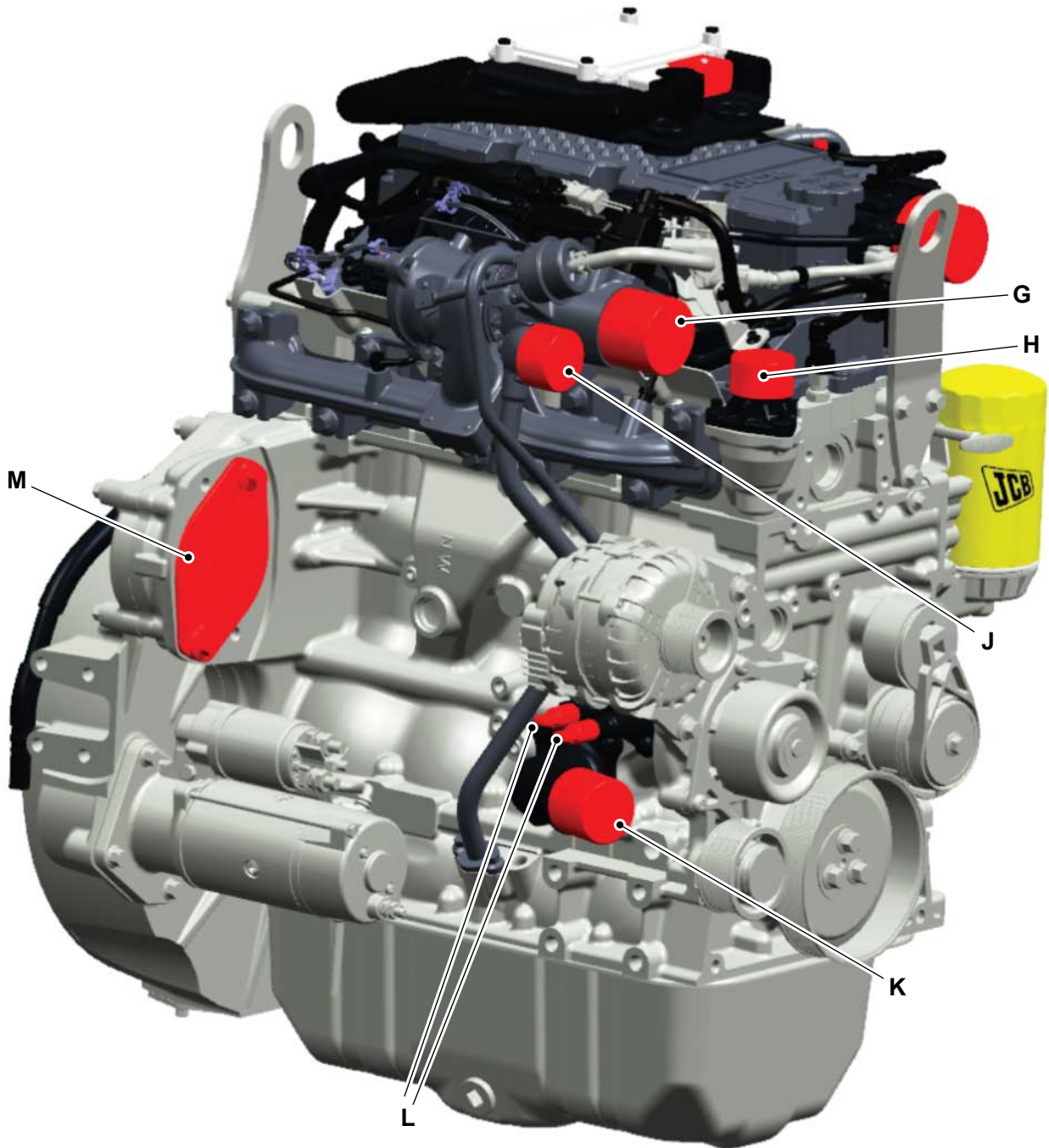
Figure 139.

- G** Turbocharger intake cap
- J** Turbocharger compressor outlet cap
- L** Cab heater feed and return spigots

- H** Coolant top hose cap
- K** Coolant bottom hose cap
- M** Heavy duty PTO (Power Take-Off)

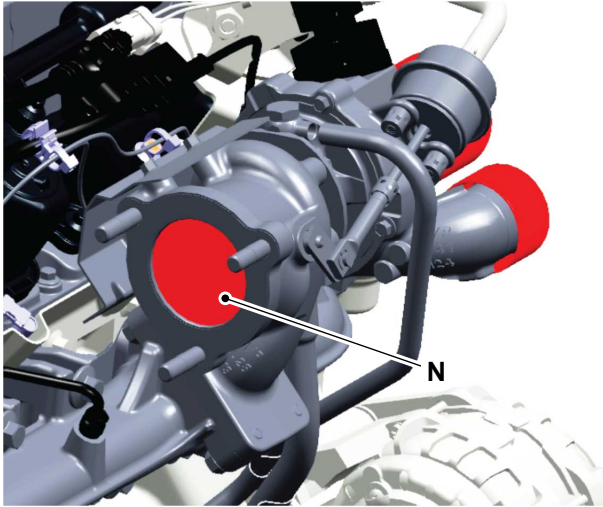
Figure 140.

N Turbocharger exhaust outlet (tape over)

12 Month Revalidation Procedure

1. Pre-inspection:
 - 1.1. Inspect packaging for signs of damage.
 - 1.2. Inspect the caps for signs of damage.
 - 1.3. Inspect openings for signs of water or dirt ingress.
 - 1.4. Inspect the engine for signs of external corrosion.
 - 1.5. Inspect the engine for signs of fluid leaks.
2. From storage:
 - 2.1. Remove the air intake caps.
 - 2.2. Make sure the engine oil level is correct.
 - 2.3. Using a suitable power supply at the correct voltage, crank the engine over for the specified time period.
Duration: 20s
 - 2.4. During cranking, check that the oil pressure switch opens using a multimeter. The switch is closed when there is no or low oil pressure and opens when oil pressure reaches a set point. After three separate cranking periods, If the oil pressure switch does not open (indicating no, or low oil pressure), contact your JCB engine dealer.
 - 2.5. Recap all engine openings.
 - 2.6. Coat any exposed bare metal with a suitable product.
 - 2.7. Electrical connectors and components should be coated with a protective spray if exposed.
 - 2.8. Cover in weatherproof packaging.

- 2.9. Place in storage, under cover on level ground or shelving.
- 2.10. Record details of work as required.
- 2.11. Do not expose to extremes of temperature or humidity.

Notice: Do not operate the starter motor for more than 20s at one time. Let the starter motor cool for at least 2min.

Table 59. Oil Pressure Switch Set Points

Oil pressure switch closed	>0.6bar (8.7psi)
Oil pressure switch open	<0.6bar (8.7psi)

OEM Commissioning Check on Engine Installation After More Than 12 Months

1. Flush the coolant system with proprietary flushing solution.
2. Refill the coolant system with 50/50 mix of long life antifreeze mixture.
3. Hot test engine according to the hot test profile. Refer to Table 60.
4. Drain engine oil and replace engine oil filter.
5. Refill with the correct oil and inhibit the cooling system using the correct product.
6. Record details of work as required.

Hot Test Description

▲ WARNING When using cleaning agents, solvents or other chemicals, you must adhere to the manufacturer's instructions and safety precautions.

All engines despatched from JCB will have been subjected to a hot test (checking items such as oil pressure, engines speeds, torque values etc.) and therefore the interior surfaces will have been coated with engine oil.

All coolant galleries are coated with CRODAFLUID PA75 corrosion inhibitor.

Stored engines will require re-inhibiting every 12 months, this will include hot testing the engine using a dynamometer. The hot test profile is:

Table 60. Hot Test Profile

Stage	Mode	Speed (rpm)	Torque (Nm)	Time (secs)
1	Speed/ Torque	830	0	50
2	Speed/ Torque	1300	50	60

Component Identification

Figure 142.

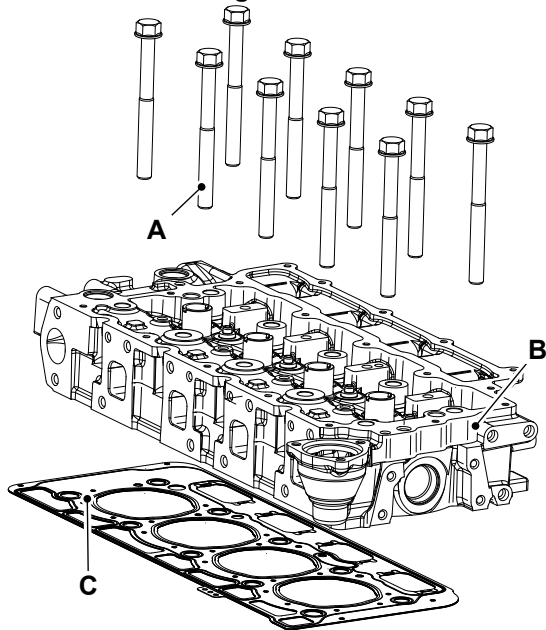

- A Cylinder head bolts
- B Cylinder head
- C Cylinder head gasket

Remove and Install

Special Tools

Description	Part No.	Qty.
Torque Wrench (10-100Nm)	993/70111	1

Consumables

Description	Part No.	Size
Cleaner/Degreaser - General purpose solvent based parts cleaner	4104/1557	0.4L

Before Removal

This procedure requires service parts. Make sure you have obtained the correct parts before you start. Refer to the Parts Catalogue.

1. Make the machine safe.
[Refer to: PIL 01-03.](#)
2. Make sure that the engine is safe to work on. If the engine has been running, let it cool before you start the service work.
3. Get access to the engine.
4. Drain the coolant.
[Refer to: PIL 21-00-00.](#)
5. Remove the engine wiring harness.
6. Remove the ECM (Engine Control Module).
[Refer to: PIL 33-45-06.](#)
7. Remove the thermostat.
[Refer to: PIL 21-12-00.](#)
8. Disconnect the CCV (Crankcase Ventilation) pipes.
[Refer to: PIL 15-28-00.](#)
9. Remove the fuel injector cover.
[Refer to: PIL 18-18-04.](#)
10. Remove the high pressure fuel pipes.
[Refer to: PIL 18-96-03.](#)
11. Remove the injector leak-off, leak-off pipe to fuel filter, and return to tank low pressure fuel pipes.
[Refer to: PIL 18-96-06.](#)
12. Remove the fuel injectors.
[Refer to: PIL 18-18-03.](#)
13. Remove the fuel rail.
[Refer to: PIL 18-18-12.](#)
14. Remove the EGR (Exhaust Gas Recirculation) system.
[Refer to: PIL 18-27-00.](#)
15. Remove the exhaust manifold pressure sensor assembly.
[Refer to: PIL 15-84-16.](#)
16. Remove the exhaust manifold and turbocharger assembly.
[Refer to: PIL 18-24-04.](#)
17. Remove the glow plugs.
[Refer to: PIL 15-80-00.](#)
18. Disconnect the charge air inlet hose.
19. Remove the rocker cover.
[Refer to: PIL 15-42-06.](#)
20. Remove the rocker assembly.
[Refer to: PIL 15-42-00.](#)

Figure 143.

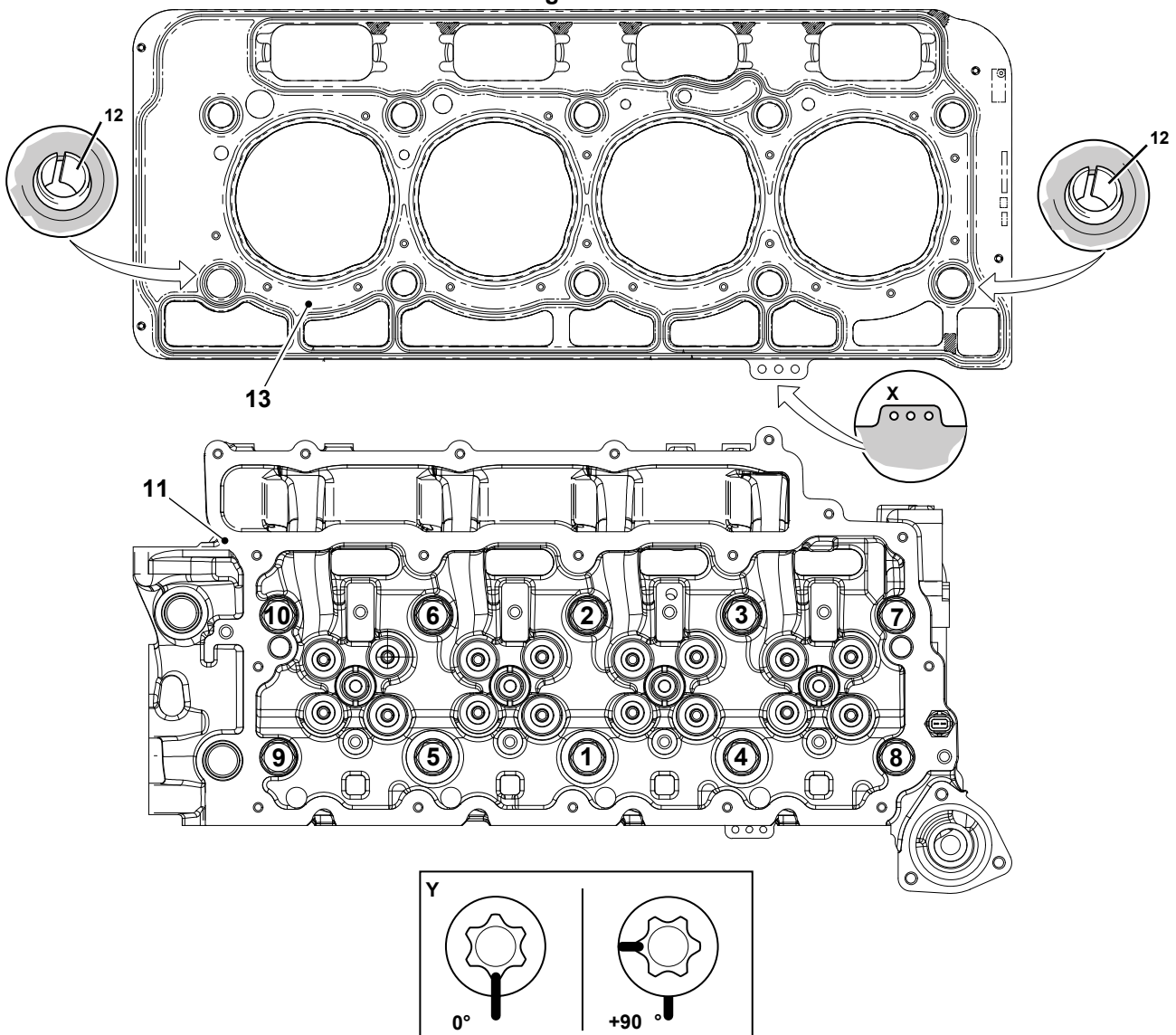

- | | |
|--|--------------------------------|
| 1-10 Cylinder head fixing bolts (x10) | 11 Cylinder head |
| 12 Location dowels (x2) | 13 Cylinder head gasket |
| X Cylinder head gasket identification holes | Y Matchmarks |

21. Remove the push rods. Make a note of the order to make sure that they are installed in their original positions.

Remove

1. Progressively remove the cylinder head bolts in reverse order, starting at bolt 10. The bolts **MUST NOT** be re-used. Discard the bolts.
2. Carefully lift the cylinder head from the crankcase. If necessary use a soft face hammer. **DO NOT** use a lever to separate the cylinder head from the crankcase. Discard the head gasket.

3. Using a suitable cleaning agent, carefully remove all traces of the head gasket material from the cylinder head and crankcase mating faces.

Consumable: [Cleaner/Degreaser - General purpose solvent based parts cleaner](#)

4. Check the cylinder head and crankcase mating faces for signs of damage and distortion.

[Refer to: PIL 15-06-00.](#)

Before Install

1. Obtain the correct new cylinder head bolts. The original bolts **MUST NOT** be re-used.

2. Obtain the correct replacement head gasket. Note the number of cylinder head gasket identification holes.
3. Make sure that all items are clean and free from damage and corrosion.

Install

1. The installation procedure is the opposite of the removal procedure. Additionally do the following steps.
2. Make sure that the location dowels are correctly installed into the crankcase. Use a dowel punch to install the dowels as required.
3. Position a new head gasket on to the crankcase mating face. Make sure that the gasket is installed the correct way around and correctly located over the dowels.
4. Lower the cylinder head on to the crankcase. Make sure that the cylinder head is correctly located on the dowels. Install new cylinder head bolts. Tighten the bolts in three stages, use the torque and angle method.

Refer to: [PIL 72-00-00](#).

- 4.1. Tighten the bolts, starting with the middle pair and working outwards (in sequence 1-10) to the 1st stage pre-torque.

Special Tool: Torque Wrench (10-100Nm)
(Qty.: 1)

- 4.2. Tighten the bolts, starting with the middle pair and working outwards (in sequence 1-10) to the 2nd stage pre-torque.
- 4.3. Repeat the 2nd stage pre-torque. Refer to step 4.2.
- 4.4. Use the angle gauge to angle tighten the bolts, starting with the middle pair and working outwards (in sequence 1-10) to the final stage torque. As a visual check, matchmark the bolts to the cylinder head before you start. When the bolts have been angle tightened, the matchmarks will appear as shown at Y. Refer to Figure 143.

Table 63. Torque Table

Item	Torque Value
1-10 (1st Stage)	50N·m
1-10 (2nd Stage)	115N·m
1-10 (Final Stage)	90°

Check (Condition)

1. Measure the crankshaft journal diameters to confirm they are within service limits.

Refer to: PIL 15-12-00.

Figure 147.

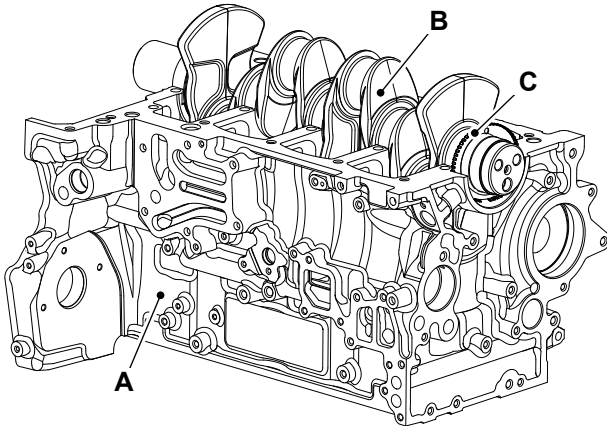

- A** Crankcase
- B** Crankshaft
- C** Crankshaft position sensor target wheel

2. Check the main bearing surfaces for damage and excessive wear.

Figure 148.

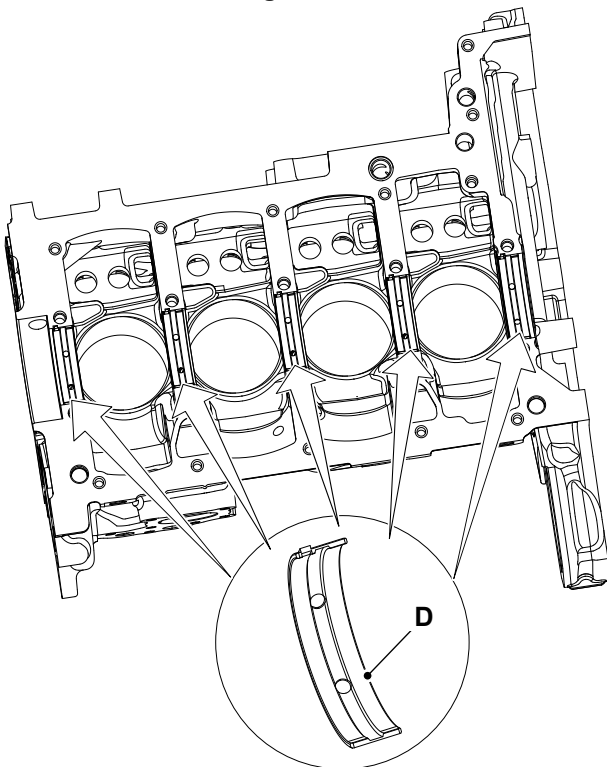

- D** Main bearing shells

3. Check that the oil-way cross drillings in the crankshaft are clear and free from debris.

Blocked or restricted oilways will cause oil starvation at the big end bearings.

4. Check that the piston cooling saddle jets are clear. If the saddle jets cannot be cleared, replace the saddle jets.

Figure 149.

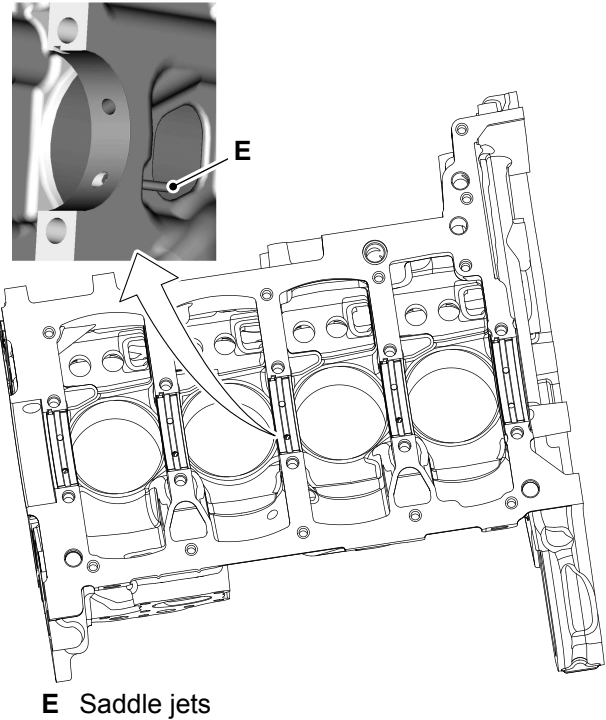

- E** Saddle jets

Remove and Install

Special Tools

Description	Part No.	Qty.
Template for Sealant Bedplate to Crankcase (430 Engine)	320/02333	1
Crankshaft Turning Tool (Major Repair) (430 Engine)	320/A3170	1
Torque Wrench (10-100Nm)	993/70111	1

Consumables

Description	Part No.	Size
Cleaner/Degreaser - General purpose solvent based parts cleaner	4104/1557	0.4L

▲ CAUTION This component is heavy. It must only be removed or handled using a suitable lifting method and device.

Before Removal

- This procedure requires service parts. Make sure you have obtained the correct service parts before you start, refer to the Parts Catalogue.
- Make sure that the engine is safe to work on. If the engine has been running, let it cool before you start the service work.
- Drain the engine oil.
[Refer to: PIL 15-21-00.](#)
- Remove the engine.
[Refer to: PIL 15-00-00.](#)
- Remove the fuel filter.
[Refer to: PIL 18-09-03.](#)
- Remove the drive belt.
[Refer to: PIL 15-18-03.](#)
- Remove the crankshaft pulley.
[Refer to: PIL 15-12-12.](#)
- Remove the front crankshaft oil seal.
[Refer to: PIL 15-12-06.](#)
- Position the engine upside down in a suitable jig or fixture, supported at the front of the crankcase.
- Remove the dipstick.
- Remove the dipstick tube.

[Refer to: PIL 15-45-09.](#)

- Remove the bolts (x2) and disconnect the turbocharger oil drain pipe.
- Remove the oil sump.
[Refer to: PIL 15-45-00.](#)
- It is not necessary to remove the cylinder head assembly to remove the crankshaft. If however the cylinder head needs to be removed for other reasons (for piston and connecting rod removal for example) remove it now.
[Refer to: PIL 15-06-00.](#)
- Remove the starter motor.
[Refer to: PIL 15-75-00.](#)
- Remove the flywheel.
[Refer to: PIL 15-54-00.](#)
- Remove the rear crankshaft oil seal.
[Refer to: PIL 15-12-09.](#)
- Remove the flywheel housing.
[Refer to: PIL 15-54-03.](#)
- Remove the oil pump.
[Refer to: PIL 15-60-00.](#)
- Remove the bolt securing the fuel hose to the bedplate.

Figure 150.

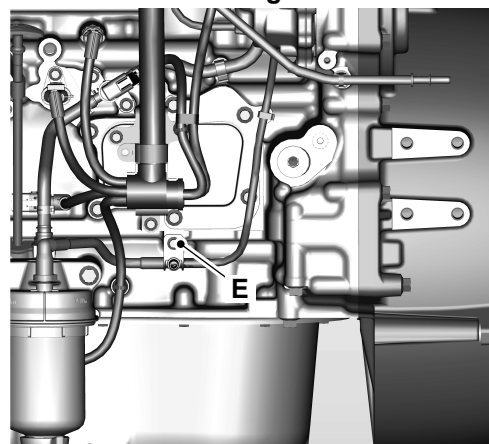

E Fuel pipe retaining bolt

- Remove the main bearing caps.
[Refer to: PIL 15-12-03.](#)
- Set the engine to TDC (Top Dead Centre).

Special Tool: Crankshaft Turning Tool (Major Repair) (430 Engine) (Qty.: 1)

Remove

1. Remove the bedplate peripheral bolts.

Figure 151.

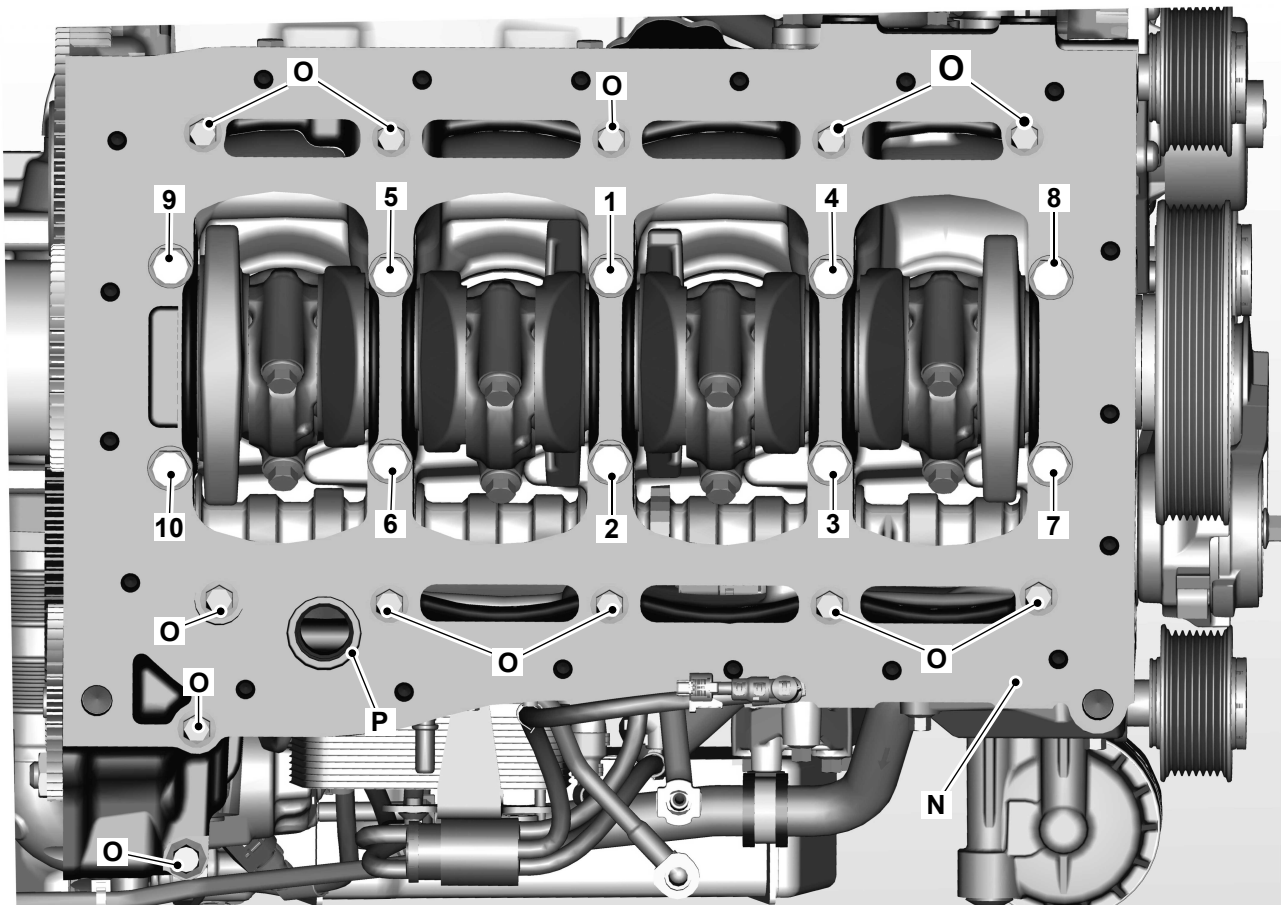

- 1-10 Main bearing bolts (x10)
- O Bedplate peripheral bolts (x12)

- N Bedplate
- P O-ring

2. Progressively remove the main bearing bolts in reverse order starting at bolt 10. The bolts MUST NOT be re-used. Discard the bolts.
3. Install the four temporary lifting bolts. Carefully separate the bedplate from the crankcase. Use suitable lifting equipment (if the bedplate is lifted manually, two people will be required). DO NOT use a lever to separate the bedplate.

Figure 152.

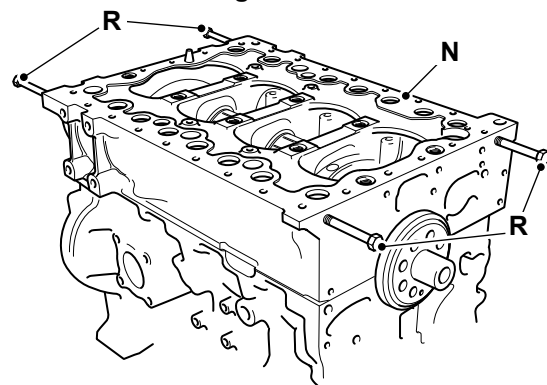

- N Bedplate
- R Lifting bolts (obtain locally)

4. Remove the bedplate.

5. Use suitable lifting equipment to carefully lift the crankshaft from the crankcase (if the crankshaft is lifted manually, two people will be required).
6. Remove the thrust washers between the crankshaft and crankcase rear main bearing.

Figure 153.

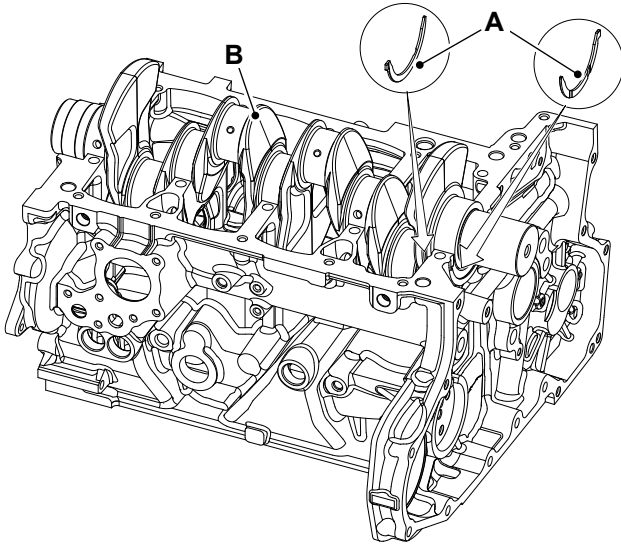

- A** Thrust washers
- B** Crankshaft
- C** Rear main bearing

7. Put labels on the thrust washers to make sure that they are installed in the correct positions during assembly.
8. Carefully lift out the bearing shells.

Figure 154.

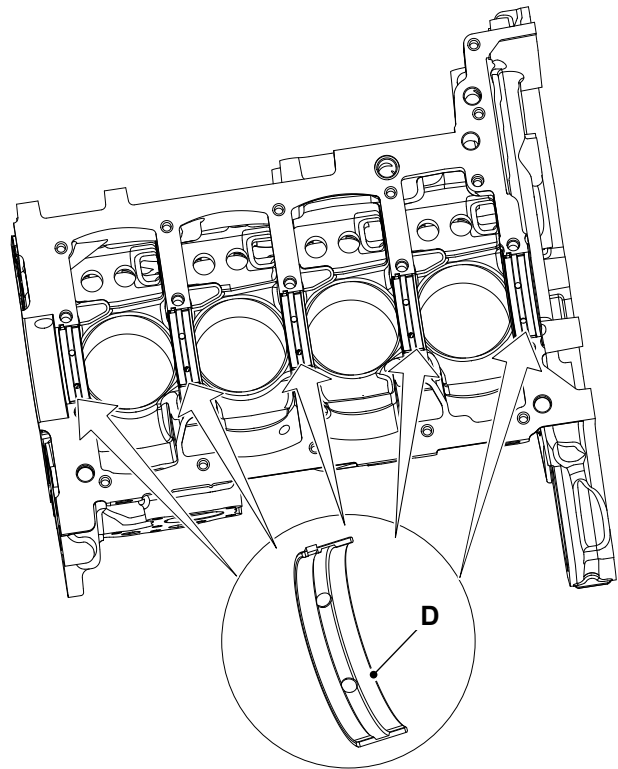

- D** Main bearing shells

9. It is recommended that the bearing shells are replaced. If however they are to be used again, put labels on the shells to make sure that they are installed in their original positions during assembly.
10. Inspect the crankshaft and main bearings for damage and excessive wear.

[Refer to: PIL 15-12-00.](#)

Before Installation

1. Clean off all traces of the old sealant compound from the crankcase and bedplate mating faces.
2. Use a suitable degreasing agent to carefully clean the main bearing saddles in the bedplate and crankcase. Take care not to block the oil ways or the piston cooling jets.

Consumable: [Cleaner/Degreaser - General purpose solvent based parts cleaner](#)

Important: Cleanliness is of the utmost importance. Blocked oil-ways or oil jets will cause engine failure. Before you install the crankshaft make sure that ALL oil-ways and jets are clear and free from debris.

Install

1. The installation procedure is the opposite of the removal procedure. Additionally do the following steps.

2. Make sure that all items are clean and free from damage and corrosion.
3. Install the upper bearing shells as follows:

Figure 155.

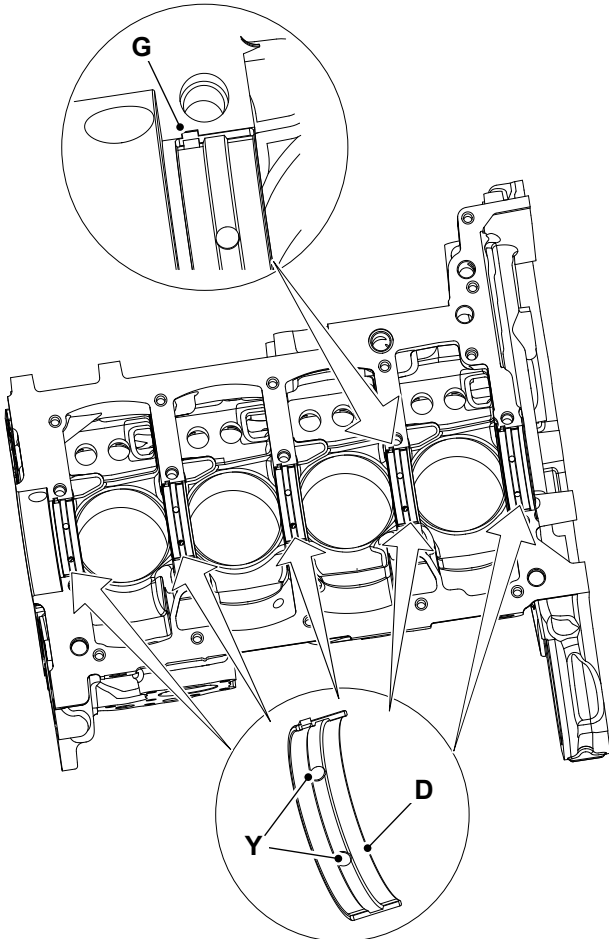

- D** Main bearing shells
- G** Bearing location tab
- Y** Oil-way holes

- 3.1. Use a suitable degreasing agent to make sure that the surfaces of the upper bearing shells are clean.

Consumable: Cleaner/Degreaser - General purpose solvent based parts cleaner

- 3.2. Assemble the bearing shells into the crankcase bearing saddles. Make sure that the location tab engages into the slot as shown.
- 3.3. Make sure that the oil-way holes in the bearing saddles align with the holes in the bearing shell. If the holes are even partially misaligned the piston cooling oil jet will be restricted, causing the engine to fail.
- 3.4. Lubricate the upper bearing shells with clean engine oil.

4. Use suitable lifting equipment (if the crankshaft is lifted manually, two people will be required), to carefully lower the crankshaft into the crankcase. **DO NOT** rotate the crankshaft, the bearing shells can become dislodged. Make sure that the connecting rods are located onto the crankshaft journals.

- 4.1. Make sure that the connecting rods are located onto the crankshaft journals.
- 4.2. Make sure that the crankshaft is installed so that the engine timing is correct. The single mark on the crankshaft drive gear must locate between the two marks on the camshaft drive gear.

Figure 156.

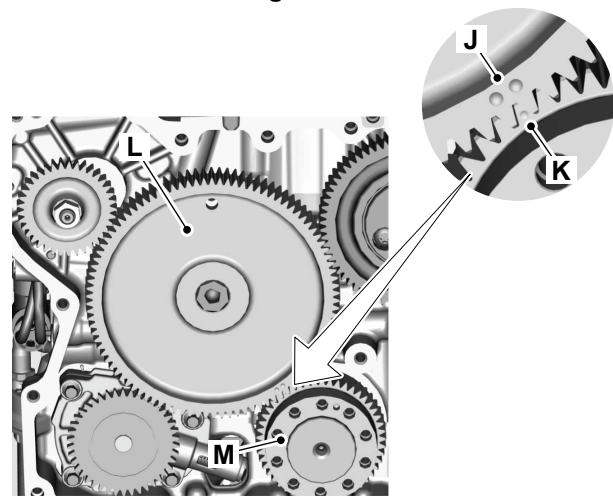

- J** Camshaft drive gear timing marks
- K** Crankshaft drive gear timing mark
- L** Camshaft drive gear
- M** Crankshaft drive gear

5. Install the thrust washers as follows:



Suggest:

If the above button click is invalid.

Please download this document

first, and then click the above link

to download the complete manual.

Thank you so much for reading

Figure 157.

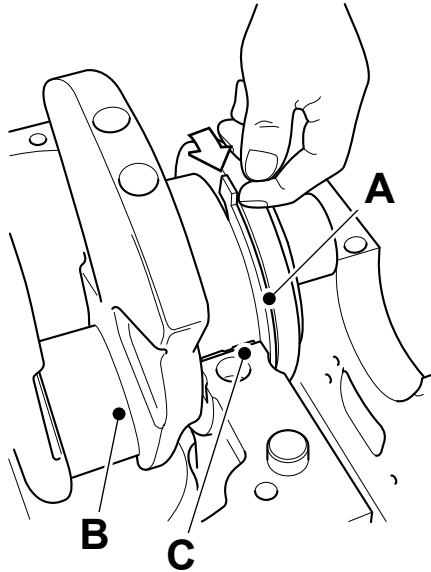
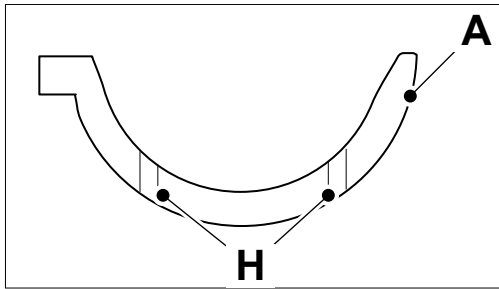

- A** Thrust washer
- B** Crankshaft
- C** Rear main bearing
- H** Oil slot - thrust washers

5.1. Slide the thrust washers between the crankshaft and the crankcase rear main bearing.

- 5.2. Make sure that they are installed in the correct positions, with the two oil slots facing outwards from the bearing saddle.
- 5.3. If necessary, push the crankshaft forward and then backwards to obtain clearance to install the thrust washers.
- 5.4. **DO NOT** rotate the crankshaft, the bearing shells can become dislodged.

6. Check that the crankshaft end float is within service limits.

[Refer to: PIL 15-12-00.](#)

7. Install the four lifting bolts to the bedplate as shown.

8. Lubricate the lower bearing shells with clean engine oil. If the bearings have been removed, make sure that the location tab engages in the slot as shown.

[Consumable: Cleaner/Degreaser - General purpose solvent based parts cleaner](#)

9. The sealant template is used on the crankcase, **NOT** the bedplate.

[Special Tool: Template for Sealant Bedplate to Crankcase \(430 Engine\) \(Qty.: 1\)](#)

10. Locate the location tabs on the template using a location dowel and a fixing bolt. Use the templates as a guide apply a bead of sealant around the crankcase/bedplate mating face as shown to the dimension specified.

Length/Dimension/Distance: 1.5mm

<https://www.ebooklibonline.com>

Hello dear friend!

Thank you very much for reading.

Enter the link into your browser.

The full manual is available for immediate download.

<https://www.ebooklibonline.com>