

# SERVICE MANUAL

LOADER  
422ZX

EN - 9813/8400 - ISSUE 3 - 09/2018

This manual contains original instructions, verified by the manufacturer (or their authorized representative).

Copyright 2018 Â© JCB SERVICE  
All rights reserved. No part of this publication may be reproduced, stored in a retrieval system, or transmitted in any form or by any other means, electronic, mechanical, photocopying or otherwise, without prior permission from JCB SERVICE.

[www.jcb.com](http://www.jcb.com)

## Foreword

### The Operator's Manual

  
You and others can be killed or seriously injured if you operate or maintain the machine without first studying the Operator's Manual. You must understand and follow the instructions in the Operator's Manual. If you do not understand anything, ask your employer or JCB dealer to explain it.

Do not operate the machine without an Operator's Manual, or if there is anything on the machine you do not understand.

Treat the Operator's Manual as part of the machine. Keep it clean and in good condition. Replace the Operator's Manual immediately if it is lost, damaged or becomes unreadable.

### Contents

**01 - Machine**

**03 - Attachments, Couplings and Load Handling**

**06 - Body and Framework**

**09 - Operator Station**

**12 - Heating, Ventilating and Air-Conditioning (HVAC)**

**15 - Engine**

**18 - Fuel and Exhaust System**

**21 - Cooling System**

**24 - Brake System**

**25 - Steering System**

**27 - Driveline**

**30 - Hydraulic System**

**33 - Electrical System**

**72 - Fasteners and Fixings**

**75 - Consumable Products**

**78 - After Sales**

## 00 - General

[Introduction .....](#) 15-63  
[Remove and Install .....](#) 15-64

## Introduction

The bedplate acts as the main strength component of the engine. It maintains the correct alignment and supports the weight of the internal components.

**Figure 124.**

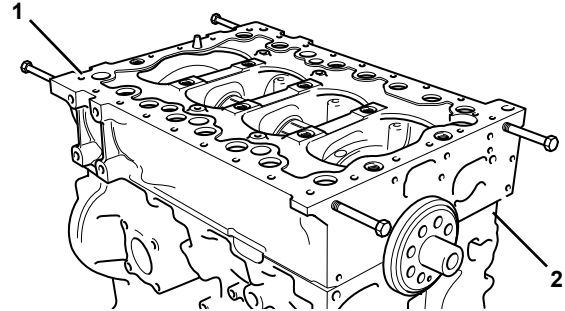

- 1 Bedplate
- 2 Crankcase

## Remove and Install

### Special Tools

Description	Part No.	Qty.
Template for Sealant Bedplate to Crankcase (4 Cyl)	892/12356	1
Torque Wrench (10-100Nm)	993/70111	1

### Consumables

Description	Part No.	Size
Cleaner/Degreaser - General purpose solvent based parts cleaner	4104/1557	0.4 L

**▲ CAUTION** This component is heavy. It must only be removed or handled using a suitable lifting method and device.

### Before Removal

This procedure requires service parts. Make sure you have obtained the correct service parts before you start. Refer to Parts Catalogue.

1. Make sure that the engine is safe to work on. If the engine has been running, let it cool before you start the service work.
2. Remove the engine, refer to (PIL 15-00).
3. Remove the drive belt, refer to (PIL 15-18).
4. Remove the crankshaft pulley, refer to (PIL 15-12).
5. Remove the oil sump, refer to (PIL 15-45).
6. Disconnect and remove the fuel pipes from the injectors, refer to (PIL 18-96).
7. Remove the rocker cover, refer to (PIL 15-42).
8. Remove the fuel injectors, refer to (PIL 18-18).
9. Remove the rocker assembly including the push rods, refer to (PIL 15-42).
10. It is not necessary to remove the cylinder head assembly to remove the crankshaft. If however the cylinder head needs to be removed for other reasons (for piston and connecting rod removal for example) remove it now, refer to (PIL 15-06).
11. Remove the fuel injection pump, refer to (PIL 18-18).
12. Remove the starter motor, refer to (PIL 15-75).

13. Remove the high duty PTO (Power Take-Off) device (if installed).
14. Position the engine upside down in a suitable jig or fixture, supported at the front of the cylinder block.
15. Remove the flywheel, refer to (PIL 15-54).
16. Remove the flywheel housing, refer to (PIL 15-54).
17. Remove the fuel injection pump drive gear, refer to (PIL 15-51).
18. Remove the oil pump, refer to (PIL 15-60).
19. Remove the CCV (Crankcase Ventilation) check valve plug and ball.

**Figure 125.**

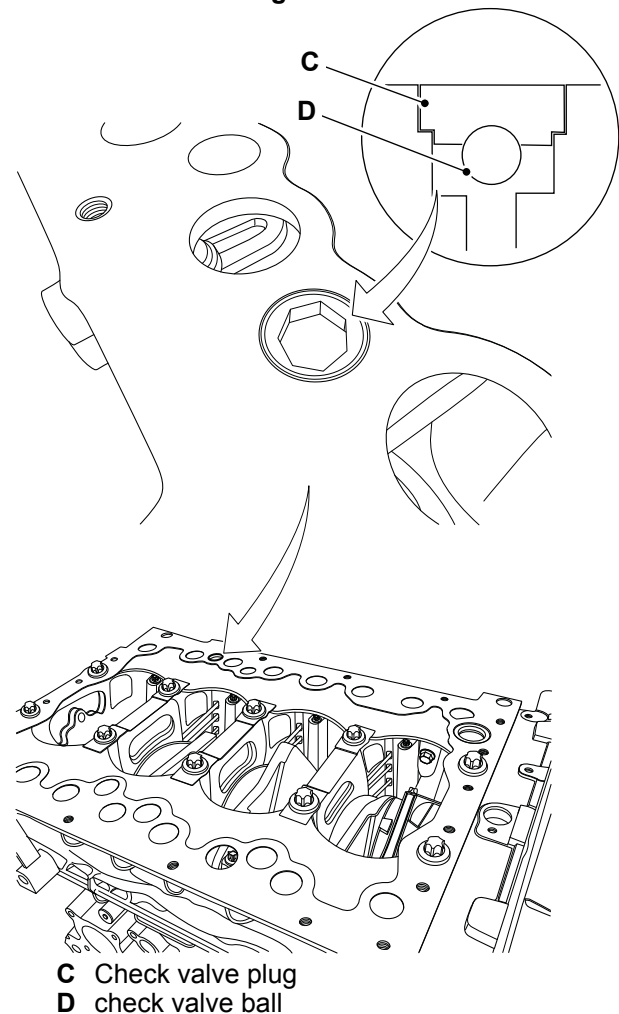

20. Remove the high duty PTO idler drive gear (if installed), refer to (PIL 15-51).

**<https://www.ebooklibonline.com>**

Hello dear friend!

Thank you very much for reading.

Enter the link into your browser.

The full manual is available for immediate download.

**<https://www.ebooklibonline.com>**

21. Remove the crankshaft drive gear, refer to (PIL 15-51).

23. Remove the rear timing case, refer to (PIL 15-51).

22. Remove the camshaft, refer to (PIL 15-15).

24. If the pistons and connecting rods have not been removed, undo and remove the main bearing caps, refer to (PIL 15-12).

**Figure 126.**

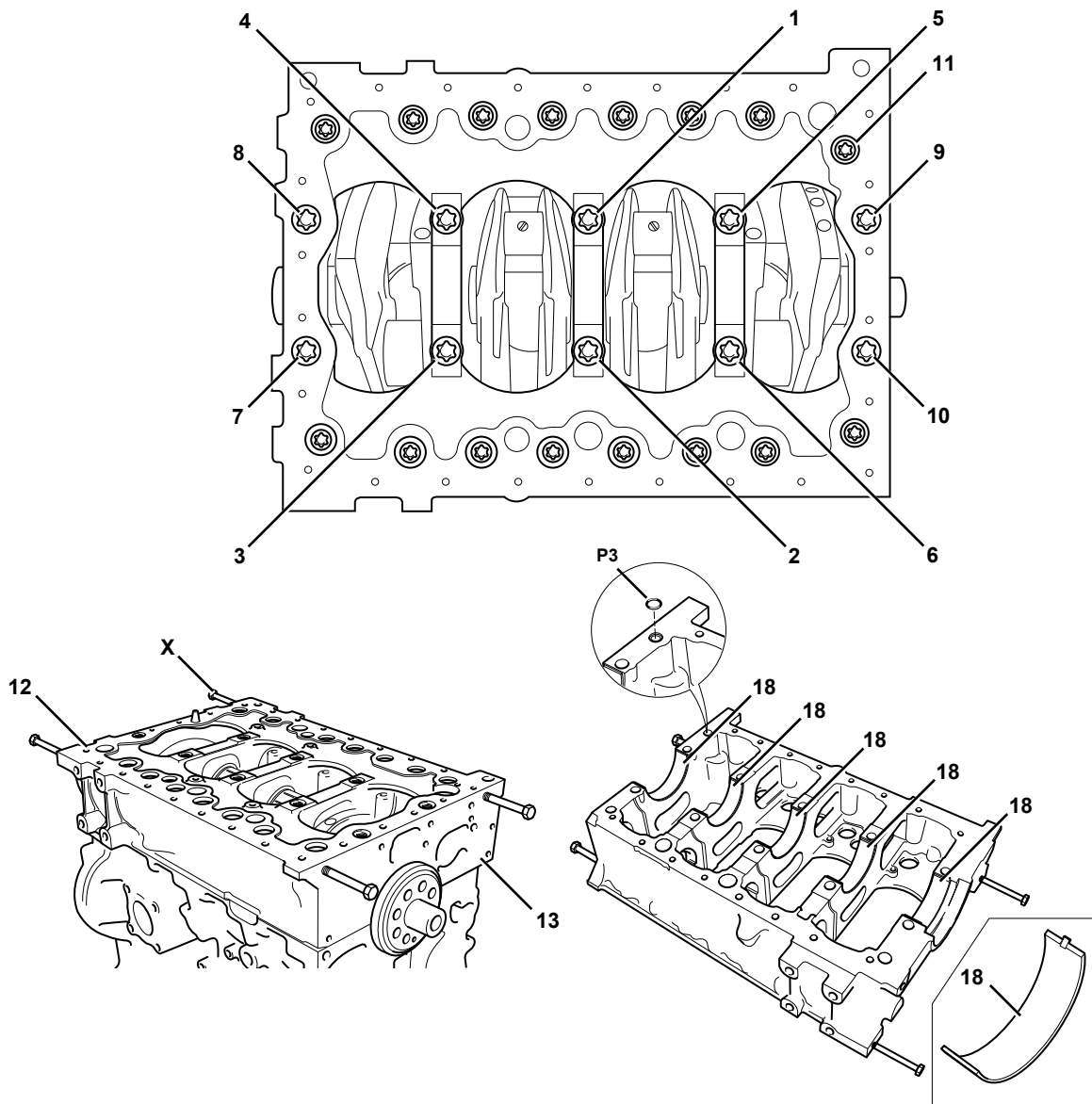

- 1-10** Main bearing bolts (x10)
- 12** Bedplate
- 18** Upper bearing shell (x5)
- T1** Lifting bolts (obtain locally)

- 11** Bedplate peripheral bolts (x16)
- 13** Crankcase
- P3** O-ring (if installed)

**Remove**

1. Remove the bedplate peripheral bolts.
2. Progressively remove the main bearing bolts in reverse order starting at bolt 10. The bolts MUST NOT be re-used. Discard the bolts.
3. Install the four temporary lifting bolts. Carefully separate the bedplate from the crankcase. Use

suitable lifting equipment (if the bedplate is lifted manually, two people will be required). DO NOT use a lever to separate the bedplate.

4. Remove and discard the O-ring.
5. Carefully remove the upper bearing shells from the bedplate, remove the bedplate.

**Figure 127.**

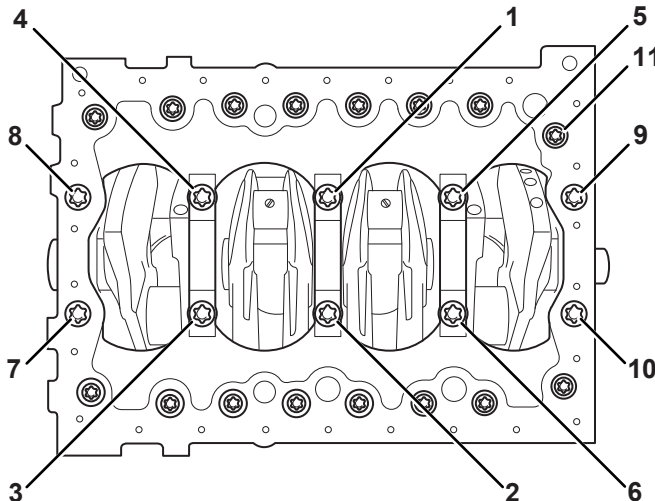
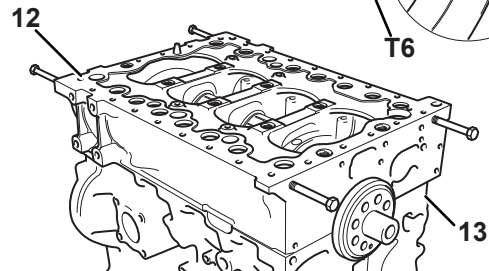
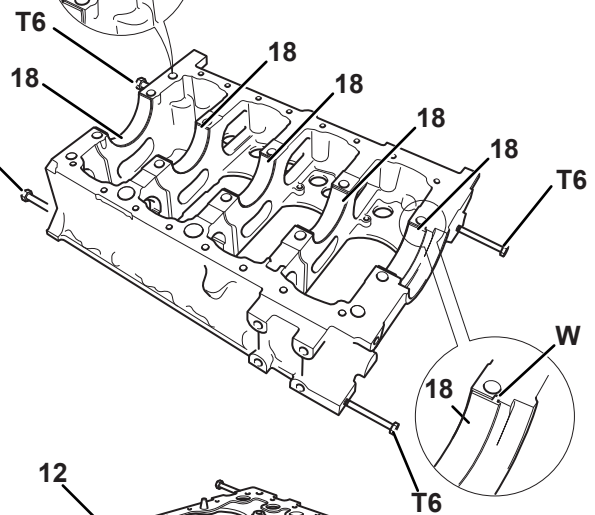
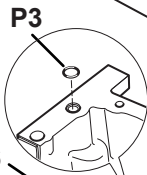
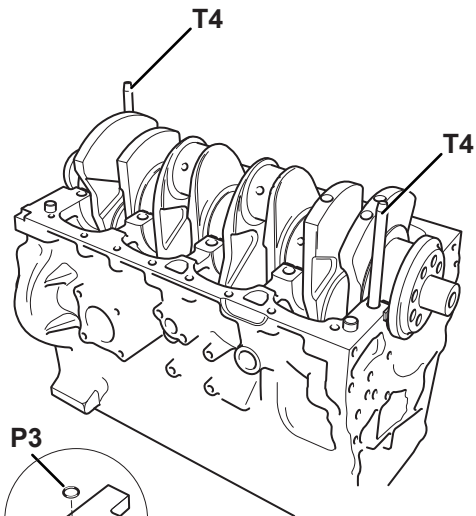
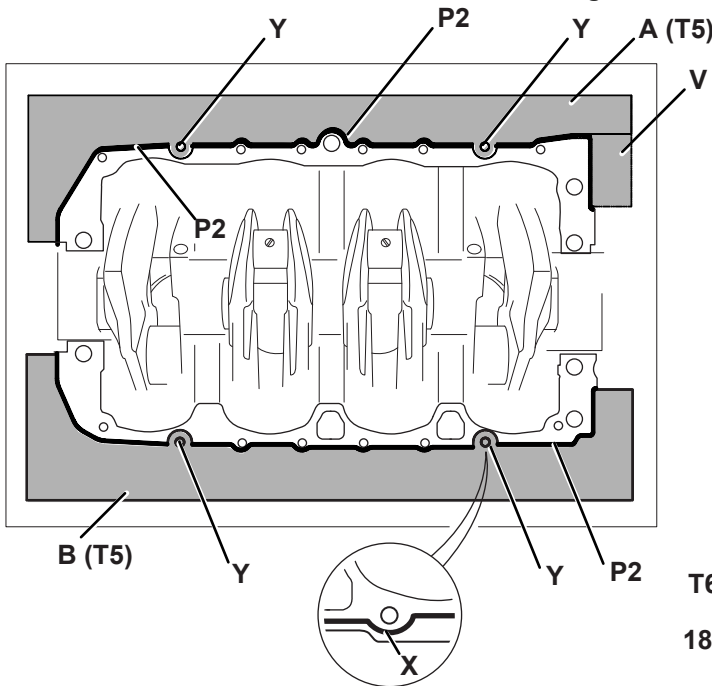

- 1-10 Main bearing bolts
- 12 Bedplate
- 18 Lower bearing shells (x5)
- B Right side template

- 11 Bedplate peripheral bolts (x16)
- 13 Crankcase
- A Left side template
- T3 Angle Gauge (obtain locally)



**T4** Guide pins (x2 obtain locally)  
**T6** Lifting bolts (x4 obtain locally)  
**W** Bearing tab  
**Y** Bearing location tab  
**P3** O-ring

**T5** Sealant template  
**V** Sealant template portion for removal  
**X** Rear main bearing  
**P2** Anaerobic sealant

## Before Installation

1. Clean off all traces of the old sealant compound from the crankcase and bedplate mating faces.
2. Use a suitable degreasing agent to carefully clean the main bearing saddles in the bedplate and crankcase. Take care not to block the oil ways or the piston cooling jets.

**Consumable:** Cleaner/Degreaser - General purpose solvent based parts cleaner

Important: Anaerobic sealant will not start to cure whilst it is open to the atmosphere, however when air is excluded (for instance when the two parts are put together) it will immediately start to harden. Make sure that all the necessary tools, bolts etc. are readily available prior to assembling the components. The parts must be installed and tightened to the correct torque value within 5 minutes (with a maximum permissible time of 15 minutes).

Important: BEFORE installing the bedplate: DO NOT rotate the crankshaft. Make sure that the upper main bearing shells are flush with the bottom face of the crankcase.

## Install

1. The installation procedure is the opposite of the removal procedure. Additionally do the following steps.
2. Make sure that all items are clean and free from damage and corrosion.
3. Install the two guide pins T4 to the crankcase bedplate fixing holes as shown.
4. Install the four lifting bolts T6 to the bedplate as shown.
5. Install a new O-ring at the bedplate.
6. Use a suitable degreasing agent to clean both sides of the lower bearing shells. Assemble the lower bearing shells into the bedplate. Lubricate the lower bearing shells with clean engine oil. Note: Make sure that the location tab W engages in the slot as shown.  
**Consumable:** Cleaner/Degreaser - General purpose solvent based parts cleaner
7. Note: The sealant template T5 is used on the crankcase, NOT the bedplate. The sealant template T5 comprises of two pieces, A and B. Modify the template A by removing portion V.  
**Special Tool:** Template for Sealant Bedplate to Crankcase (4 Cyl) (Qty.: 1)
8. Locate the holes in the templates A and B using four fixing bolts at positions Y. Use the templates

as a guide apply beads of sealant P2 around the crankcase/bedplate mating face as shown to the dimension specified.

Length/Dimension/Distance: 1.5mm

9. Remove the four fixing bolts at positions Y. Remove the templates A and B, make sure you do not smudge the sealant. Discard the templates.
10. Add beads of sealant P2 around the four bolt holes at positions Y, so as to join the sealant beads as shown at X.
11. Make sure that the location guide pins T4 are in position in the crankcase. Assemble the bedplate to the crankcase use the alignment guide pins.
12. Note: The bedplate is heavy. Two people will be required to lift and rotate the bedplate safely on to the crankcase. Install new main bearing bolts 1-10. Tighten the bolts to the correct torque value in pairs, starting in the centre and working outwards (in sequence 1-10) to the 1st stage pre-torque.  
**Special Tool:** Torque Wrench (10-100Nm) (Qty.: 1)
13. Install the bedplate peripheral bolts. Tighten the bolts to the correct torque value.
14. After installation and tightening the bedplate peripheral bolts, further tighten the main bearing bolts in pairs, starting in the centre and working outwards (in sequence 1-10) to the 2nd stage pre-torque.
15. Finally, angle tighten the main bearing bolts in pairs, starting in the centre and working outwards (in sequence 1-10) for the final stage torque. Use the torque and angle method, refer to Fasteners and Fixings, General, Introduction (PIL 72-00).

Important: If the parts have not been tightened to the correct torque value within the maximum 15 minute time period, then the parts must be separated, thoroughly cleaned and fresh sealant applied.

## After Installation

1. Check that the crankshaft can be freely rotated by hand. Remove the bedplate lifting bolts T6.
2. Carry out the procedures listed, before removal in reverse order. Additionally do the following step.
3. Tighten the CCV check valve plug to the correct torque value.

**Table 68. Torque Table**

<b>Item</b>	<b>Torque Value</b>
1-10 (1st Stage)	50N·m
1-10 (2nd Stage)	115N·m
1-10 (Final Stage)	180°
11	24N·m
C	45–55N·m

## Operation

### Lubrication

Oil is fed from the main gallery via five drillings, one to each of the main bearings. A groove around the diameter of the upper main bearing shell allows oil

transfer to cross drillings in the crankshaft to feed each of the big end bearings. Crankshaft gear is 'splash' lubricated. Front and rear crankshaft oil seals prevent oil leakage from, and dirt ingress to, the engine.

Figure 129.

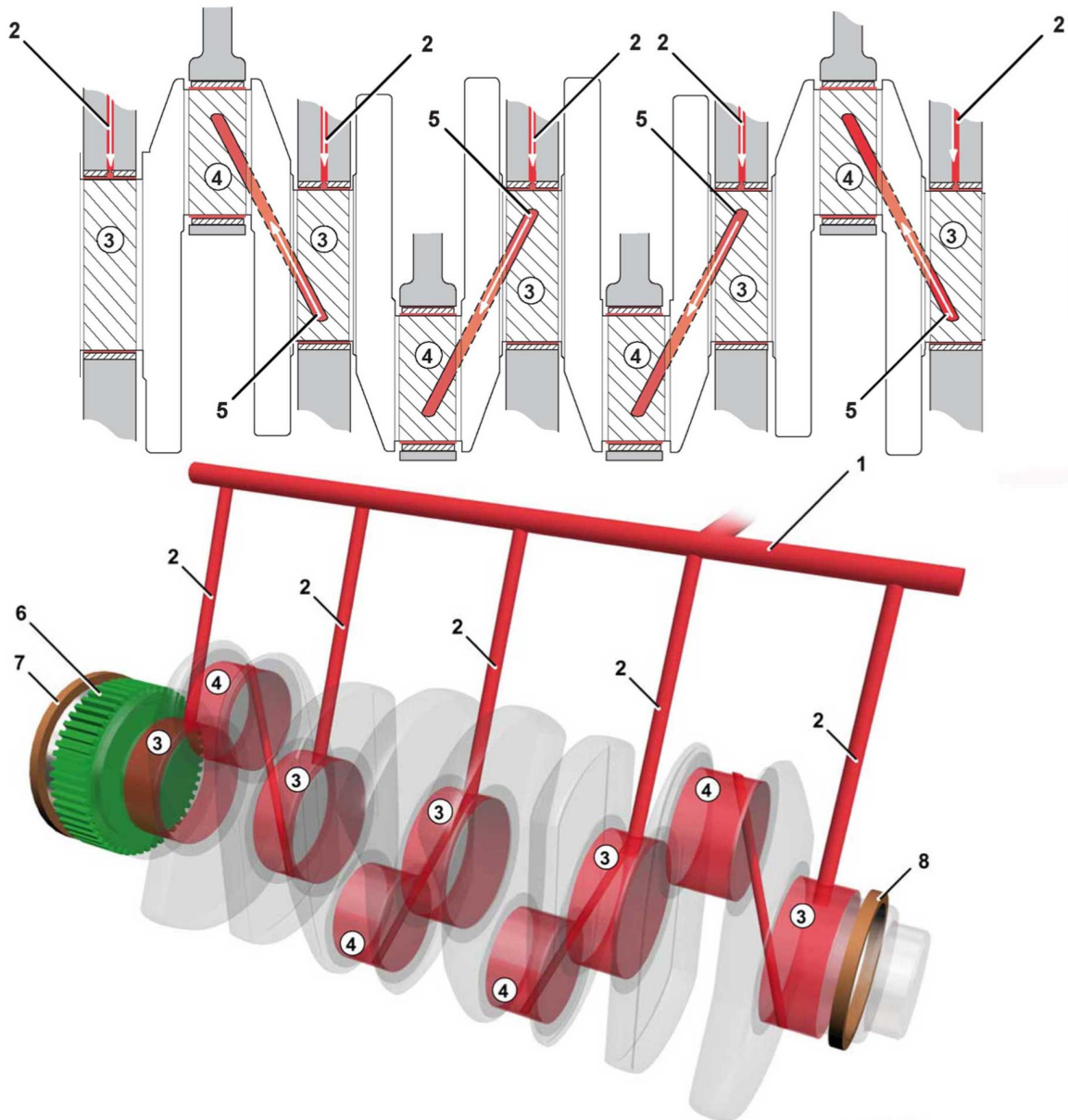

- 1 Main gallery
- 3 Main bearings
- 5 Cross drillings
- 7 Crankshaft oil seal

- 2 Drillings (x5)
- 4 Big end bearings
- 6 Crankshaft gear
- 8 Crankshaft oil seal

## Check (Condition)

1. Check the main bearing surfaces for damage and excessive wear.

**Figure 130.**

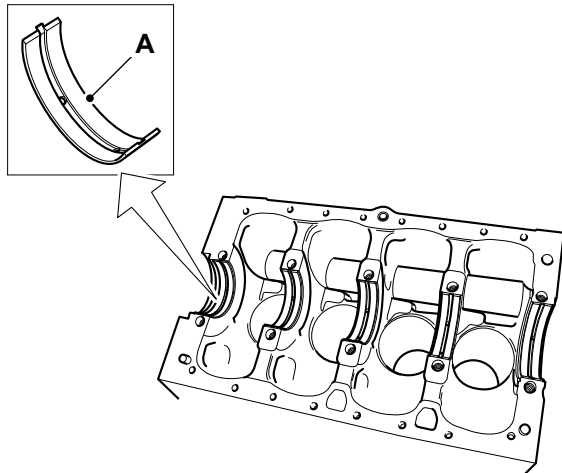

**A** Main bearing shells

2. Measure the crankshaft diameters to confirm they are within service limits, refer to Technical Data (PIL 15-12).

**Figure 131.**

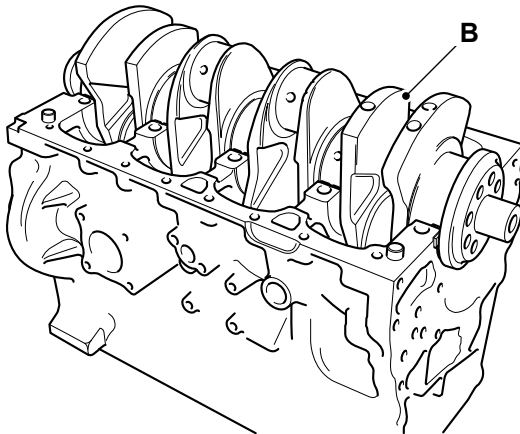

**B** Crankshaft

3. Check that the oil-way cross drillings in the crankshaft are clear and free from debris. Blocked or restricted oil-ways will cause oil starvation at the big end bearings.
4. Check that the piston cooling J-jets are clear. If the J-jets cannot be cleared remove the fixing screws. Remove the J-jets and discard them.
5. Install new J-jets.

**Figure 132.**

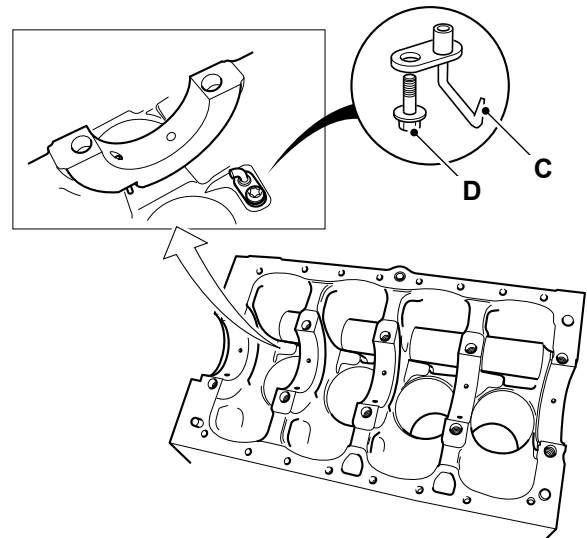

**C** J-jets  
**D** Fixing screws

## Remove and Install

### Consumables

Description	Part No.	Size
Cleaner/Degreaser - General purpose solvent based parts cleaner	4104/1557	0.4 L

**▲ CAUTION** This component is heavy. It must only be removed or handled using a suitable lifting method and device.

### Before Removal

1. This procedure requires service parts. Make sure you have obtained the correct service parts before you start, refer to Parts Catalogue.
2. Make sure that the engine is safe to work on. If the engine has been running, let it cool before you start the service work.
3. Remove the engine, refer to (PIL 15-00).
4. Remove the drive belt, refer to (PIL 15-18).
5. Remove the crankshaft pulley, refer to (PIL 15-12).
6. Remove the oil sump, refer to (PIL 15-45).
7. Disconnect and remove the fuel pipes from the injectors, refer to (PIL 18-96).
8. Remove the rocker cover, refer to (PIL 15-42).
9. Remove the fuel injectors, refer to (PIL 18-18).
10. Remove the rocker assembly including the push rods, refer to (PIL 15-42).
11. It is not necessary to remove the cylinder head assembly to remove the crankshaft. If however the cylinder head needs to be removed for other

reasons (for piston and connecting rod removal for example) remove it now, refer to (PIL 15-06).

12. Remove the fuel injection pump, refer to (PIL 18-18).
13. Remove the starter motor, refer to (PIL 15-75).
14. Remove the high duty PTO device (if installed).
15. Position the engine upside down in a suitable jig or fixture, supported at the front of the cylinder block.
16. Remove the flywheel, refer to (PIL 15-54).
17. Remove the flywheel housing, refer to (PIL 15-54).
18. Remove the fuel injection pump drive gear, refer to (PIL 15-51).
19. Remove the oil pump, refer to (PIL 15-60).
20. Remove the high duty PTO idler drive gear (if installed), refer to (PIL 15-51).
21. Remove the crankshaft drive gear, refer to (PIL 15-51).
22. Remove the camshaft, refer to (PIL 15-15).
23. Remove the rear timing case, refer to (PIL 15-51).
24. If the pistons and connecting rods have not been removed, undo and remove the main bearing caps, refer to (PIL 15-12).
25. Remove the bedplate, refer to (PIL 15-09).

### Remove

1. Remove the thrust washers between the crankshaft and crankcase rear main bearing.

**Figure 133.**

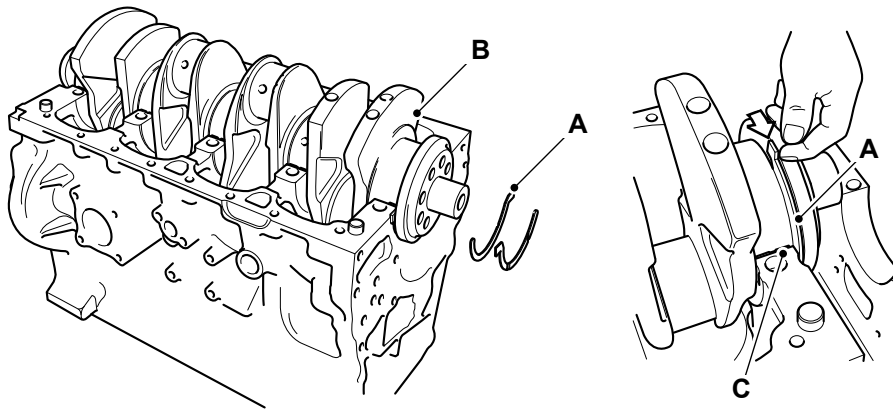

- A** Thrust Washers
- C** Rear main bearing

- B** Crankshaft

2. Put labels on the thrust washers to make sure that they are installed in the correct positions during assembly.
3. Use suitable lifting equipment to carefully lift the crankshaft from the crankcase (if the crankshaft is lifted manually, two people will be required).
4. Carefully lift out the bearing shells.

**Before Installation**

1. Clean off all traces of the old sealant compound from the crankcase and bedplate mating faces.
2. Use a suitable degreasing agent to carefully clean the main bearing saddles in the bedplate and crankcase. Take care not to block the oil ways or the piston cooling jets.

**Consumable:** [Cleaner/Degreaser - General purpose solvent based parts cleaner](#)

**Important:** Cleanliness is of the utmost importance. Blocked oil-ways or oil jets will cause engine failure. Before you install the crankshaft make sure that ALL oil-ways and jets are clear and free from debris.

**Figure 134.**

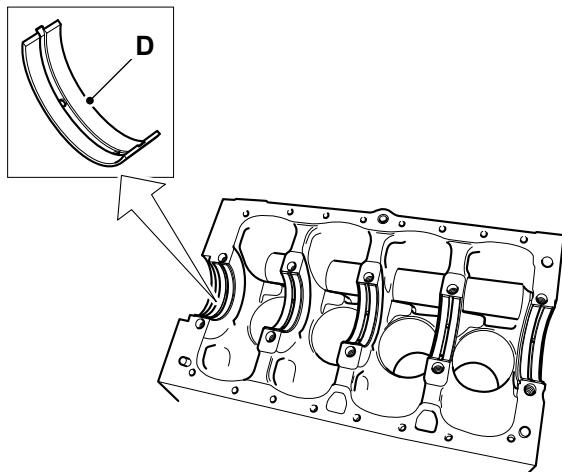

- D** Main bearing shells

5. It is recommended that the bearing shells are replaced. If however they are to be used again, put label on the shells to make sure that they are installed in their original positions during assembly.
6. Inspect the crankshaft and main bearings etc. for damage and excessive wear. Refer to Check Condition (PIL 15-12).

**Install**

1. The installation procedure is the opposite of the removal procedure. Additionally do the following steps.
2. Make sure that all items are clean and free from damage and corrosion.
3. If removed or a new crankcase is being installed then install cooling J jets as follows:

**Figure 135.**

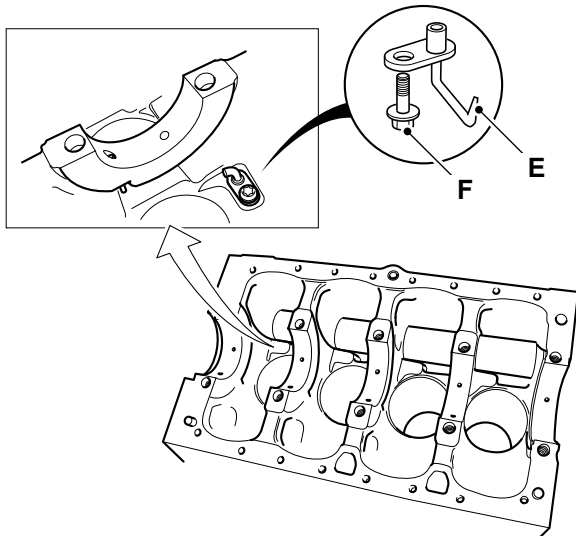

- E** J jets (x4)
- F** Fixing screws

- 3.1. Insert the cooling jets into the crankcase.
- 3.2. Note: There are different types of cooling jets installed depending on the engine application. The jets are colour coded.
- 3.3. Be sure to install the correct jets. Refer to the relevant parts catalogue for the correct cooling jet identification.
- 3.4. Tighten the retaining screws to the correct torque value.

4. Install the upper bearing shells as follows:

**Figure 136.**

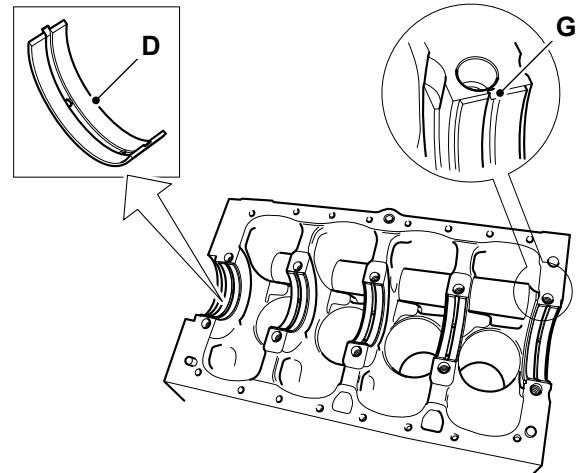

- D** Main bearing shells
- G** Bearing location tab

- 4.1. Use a suitable degreasing agent to make sure that the surface of the upper bearing shells are clean.

[Consumable: Cleaner/Degreaser - General purpose solvent based parts cleaner](#)

- 4.2. Assemble the bearing shells into the crankcase bearing saddles. Make sure that the location tab engages into the slot as shown.
- 4.3. Important: Make sure that the oil-way holes in the bearing saddles align with the holes in the bearing shell. If the holes are even partially misaligned the piston cooling oil jet will be restricted, causing the engine to fail.
- 4.4. Lubricate the upper bearing shells with clean engine oil.
5. Use suitable lifting equipment (if the crankshaft is lifted manually, two people will be required), to carefully lower the crankshaft into the crankcase. DO NOT rotate the crankshaft, the bearing shells can become dislodged, refer to step 4.
6. Install the thrust washers as follows:

**Figure 137.**

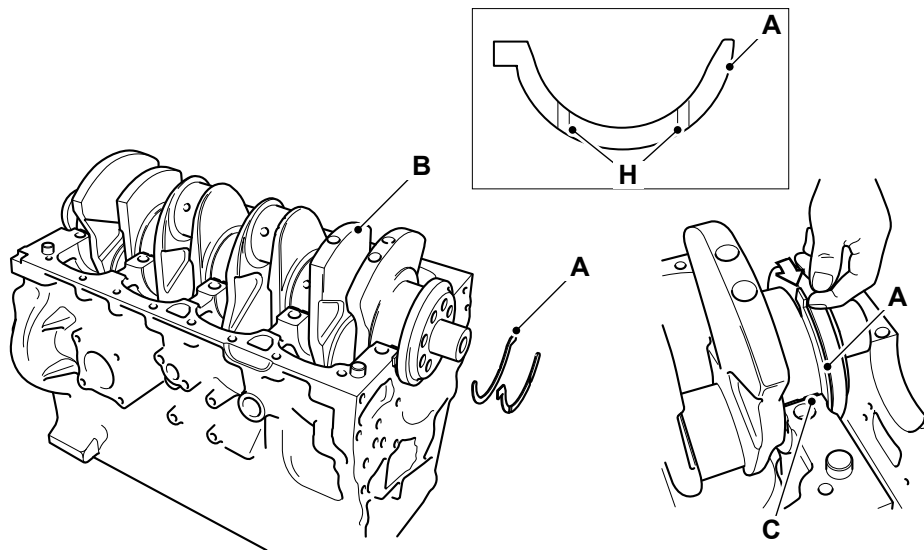

**A** Thrust washers  
**C** Rear main bearing

**B** Crankshaft  
**H** Oil slot - thrust washers

- 6.1. Slide the thrust washers between the crankshaft and the crankcase rear main bearing.
  - 6.2. Make sure that they are installed in the correct positions, with the two slots facing outwards from the bearing saddle.
  - 6.3. If necessary, push the crankshaft forward and then backwards to obtain clearance to install the thrust washers.
  - 6.4. DO NOT rotate the crankshaft, the bearing shells can become dislodged, refer to step 4.
7. Check that the crankshaft end float is within service limits, refer to Technical Data (PIL 15-12).

**Table 70. Torque Values**

Item	Nm
F	24

## 03 - Main Bearing

Introduction .....	15-80
Check (Condition) .....	15-81
Remove and Install .....	15-81

## Introduction

In a piston engine, the main bearings are the bearings on which the crankshaft rotates.

The bearings hold the crankshaft in place and prevent the forces created by the piston and transmitted to the crankshaft by the connecting rods from dislodging the crankshaft, instead forcing the crank to convert the reciprocating movement into rotation.

**Figure 138.**

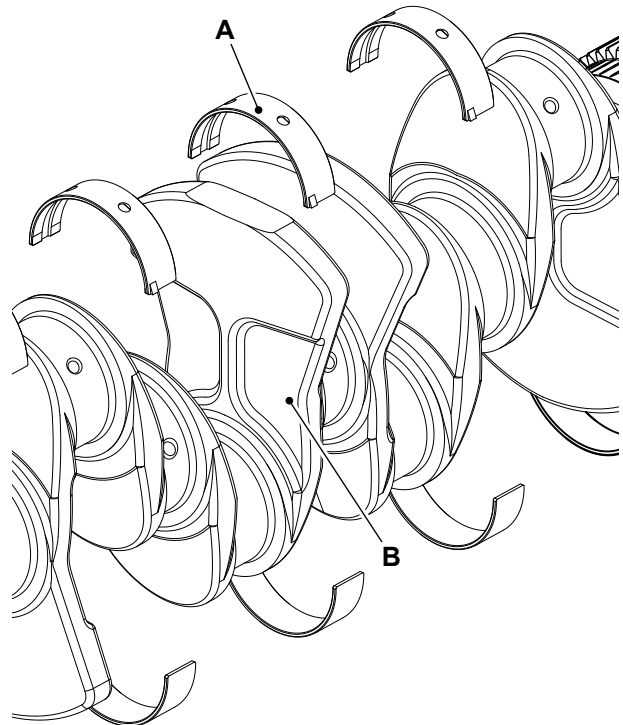

- A** Main bearing
- B** Crankshaft

## Check (Condition)

1. Check the bearing shell surfaces for signs of damage and excessive wear.
2. Measure the crank pin diameters to confirm they are within service limits.  
[Refer to: PIL 15-12-00.](#)
3. Renew any parts that are worn or not within the specified tolerances.

## Remove and Install

[Refer to: PIL 15-12-00.](#)

## 06 - Front Oil Seal

### Remove and Install

(For: JCB Tier 2/3 Elec Engine 4 Cyl)

#### Special Tools

Description	Part No.	Qty.
Crankshaft Front Oil Seal Installation Tool	892/01157	1

#### Before Removal

1. This procedure requires service parts. Make sure you have obtained the correct service parts before you start, refer to Parts Catalogue.
2. Make sure that the engine is safe to work on. If the engine has been running, let it cool before you start the service work.
3. Get access to the engine.
4. Remove the drive belt, refer to (PIL 15-18).
5. Remove the crankshaft pulley, refer to (PIL 15-12-12).

#### Remove

1. Use a suitable lever behind the lip of the seal, carefully prise out the oil seal from the counterbore in the crankcase. Take care not to scratch or damage the counterbore or the crankshaft hub. Damaged or dirty sealing faces will cause the oil seal to fail.

**Figure 139.**

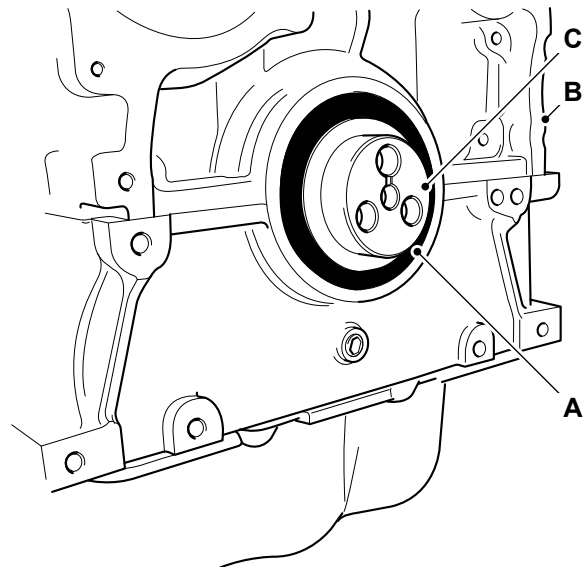

- A** Crankshaft oil seal
- B** Crankcase
- C** Crankshaft hub

#### Install

1. Make sure that the counterbore and the crankshaft hub are clean and free from damage and corrosion. Use a suitable degreasing agent to clean all traces of oil and grease from the counterbore. Important: The oil seal has a special coating and **MUST** be installed dry without lubricant.
2. Dismantle the seal installation tool. Bolt the centre body to the crankshaft hub, using the bolts. Refer to Figure 140.

**Special Tool: Crankshaft Front Oil Seal Installation Tool (Qty.: 1)**

3. Install the oil seal on to the centre body. Make sure that the seal is installed the correct way around. Assemble the outer sleeve on to the centre body and install the screw. Refer to Figure 140.

**Figure 140.**

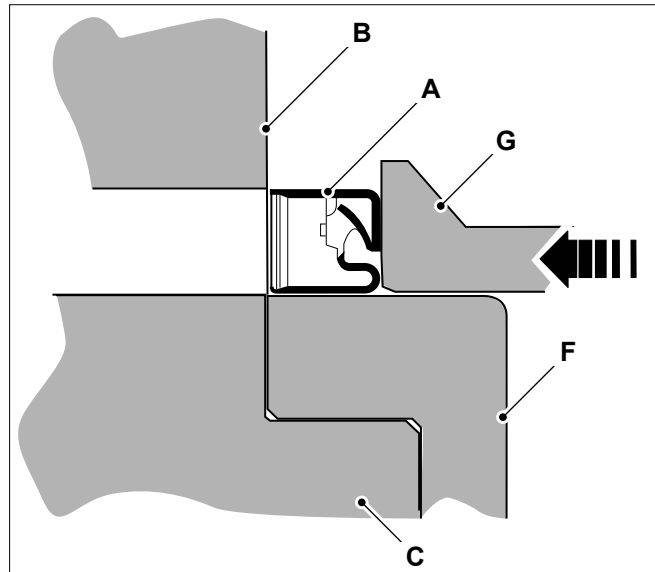
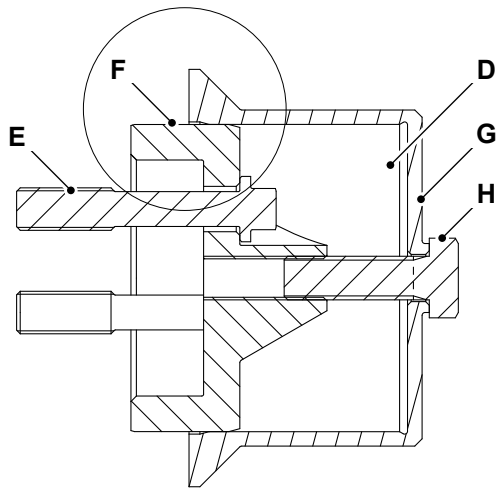

- A** Crankshaft oil seal
- C** Crankshaft hub
- E** Fixing bolts (x3)
- G** Outer sleeve

- B** Crankcase
- D** Seal installation tool
- F** Centre body
- H** Screw

4. Turn the screw to push the seal squarely into the counterbore until the outer sleeve comes up against the front edge of the counterbore. When correctly installed, the front face of the seal should be flush with the edge of the counterbore within the specified tolerance. Refer to Figure 141.

Dimension:  $-0.5 -0/+0.5\text{mm}$

**Figure 141.**

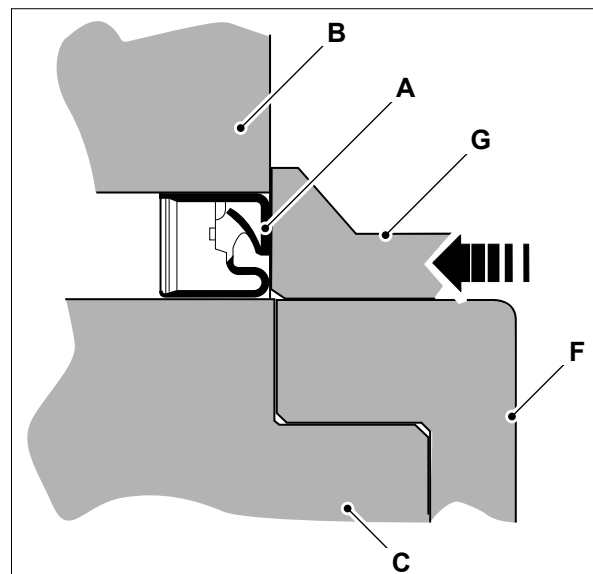

- A** Crankshaft oil seal
- B** Crankcase
- C** Crankshaft hub
- F** Centre body
- G** Outer sleeve

5. Remove the seal installation tool.



### **After Installation**

1. Install the crankshaft pulley, refer to (PIL 15-12-12).
2. Install the drive belt, refer to (PIL 15-18).

## 09 - Rear Oil Seal

### Remove and Install

(For: JCB Tier 2/3 Elec Engine 4 Cyl)

#### Special Tools

Description	Part No.	Qty.
Crankshaft Rear Oil Seal Installation Tool	892/01156	1
Crankshaft Rear Oil Seal Alignment Tool	892/01158	1

Note: The flywheel hub and crankshaft rear oil seal need to be replaced as a pair.

#### Before Removal

1. This procedure requires service parts. Make sure you have obtained the correct service parts before you start, refer to Parts Catalogue.
2. Make sure that the engine is safe to work on. If the engine has been running, let it cool before you start the service work.
3. Get access to the engine.
4. Remove the flywheel, refer to (PIL 15-54).

#### Remove

1. Use a suitable lever behind the lip of the seal to carefully prise out the rear oil seal from the counterbore in the flywheel housing. Take care not to scratch or damage the counterbore or the flywheel hub. Damaged or dirty sealing faces will cause the oil seal to fail.

**Figure 142. 24mm Hub**

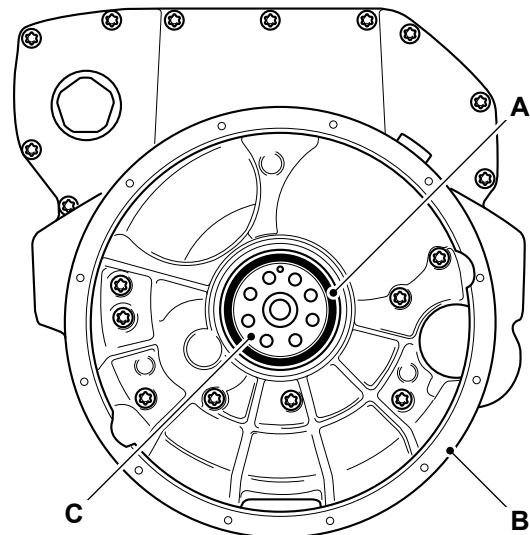

- A Crankshaft rear oil seal
- B Flywheel housing
- C Flywheel hub

**Figure 143. 15mm Hub**

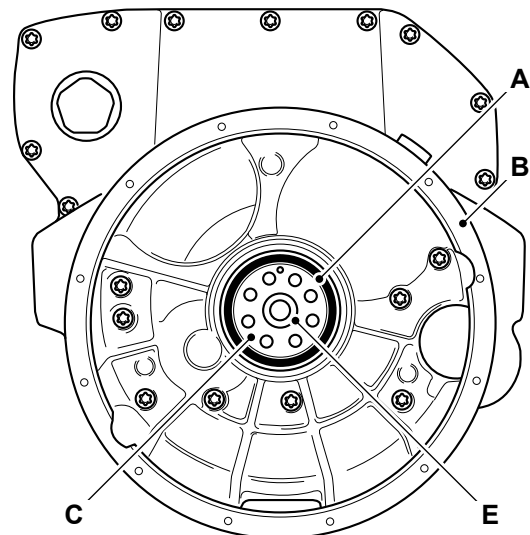

- A Crankshaft rear oil seal
- B Flywheel housing
- C Flywheel hub
- E Fixing bolt

#### Install (24mm Hub)

1. Make sure that the counterbore and the flywheel hub are clean and free from damage and corrosion.

**Figure 144.**

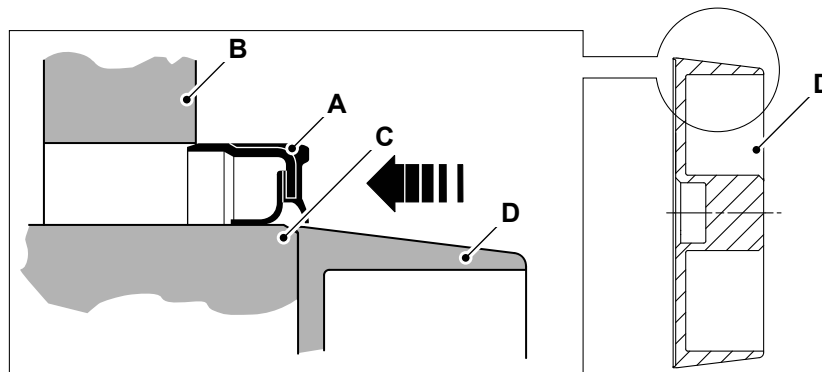

- A** Crankshaft rear oil seal
- C** Flywheel hub

- B** Flywheel housing
- D** Oil seal alignment tool

2. To prevent the seal lip rolling over and becoming damaged, make sure that you use the oil seal alignment tool to initially install the oil seal on to the flywheel hub. Locate the alignment tool over the end of the hub, then carefully push the oil seal over the alignment tool and on to the crankshaft diameter. Make sure that the oil seal is installed the correct way around.

**Special Tool: Crankshaft Rear Oil Seal Installation Tool (Qty.: 1)**

**Special Tool: Crankshaft Rear Oil Seal Alignment Tool (Qty.: 1)**

3. Apply lubricant P80 around the seal outer rubber diameter.
4. Dismantle the oil seal installation tool. Bolt the centre body to the flywheel hub, using the two flywheel bolts. Assemble the outer sleeve on to the centre body and install the screw.

**Figure 145.**

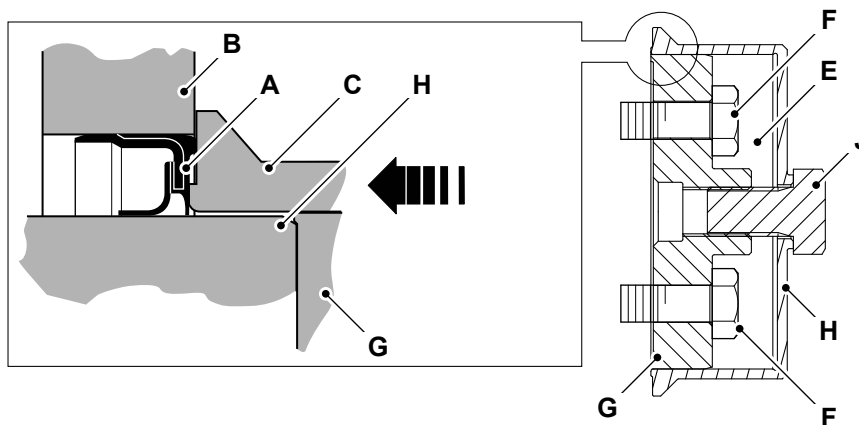

- A** Crankshaft rear oil seal
- C** Outer sleeve
- F** Flywheel bolts
- H** Flywheel hub

- B** Flywheel housing
- E** Oil seal installation tool
- G** Centre body
- J** Screw

5. Turn the screw to push the seal squarely into the counterbore until the outer sleeve comes up against the front edge of the counterbore. When correctly installed, the front face of the seal should be flush with the edge of the counterbore within the tolerance specified.

Length/Dimension/Distance: 0.5mm

6. Remove the oil seal installation tool.

**Install (15mm Hub)**

1. Make sure that the counterbore and the hub are clean and free from damage.

**Figure 146.**

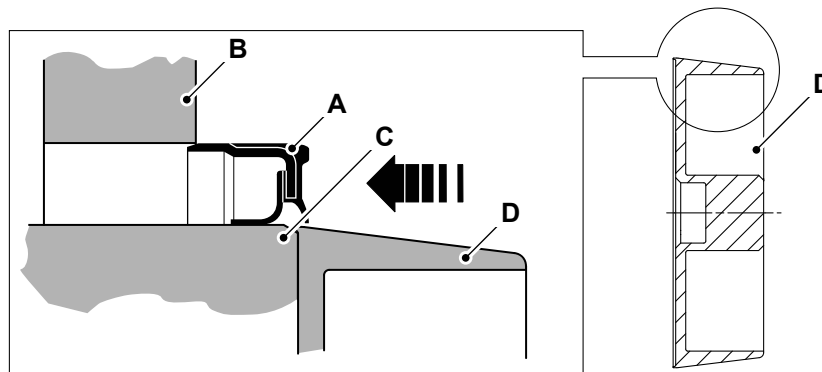

- A** Crankshaft rear oil seal
- C** Flywheel hub

- B** Flywheel housing
- D** Oil seal alignment tool

2. Install the new hub on to the crankshaft gear and install the old hub on the outside of the new hub to create a double thickness flywheel hub, install the fixing bolt as shown at A. Do not touch the PTFE seal lips of the crankshaft oil seal.
3. Make sure that you use the oil seal alignment tool to initially install the oil seal on to the flywheel hub to prevent damage to the seal lip. Locate the alignment tool over the end of the hub, carefully push the oil seal over the alignment tool as far on to the crankshaft hub as possible. Make sure that the seal is installed the correct way around.

[Special Tool: Crankshaft Rear Oil Seal Installation Tool \(Qty.: 1\)](#)  
[Special Tool: Crankshaft Rear Oil Seal Alignment Tool \(Qty.: 1\)](#)

4. Apply the lubricant P80 around the seal outer rubber diameter.
5. Dismantle the oil seal installation tool. Use the two flywheel bolts to attach the centre body on to the flywheel hub. Assemble the outer sleeve on to the centre body include the extension ring and install the screw.

**Figure 147.**

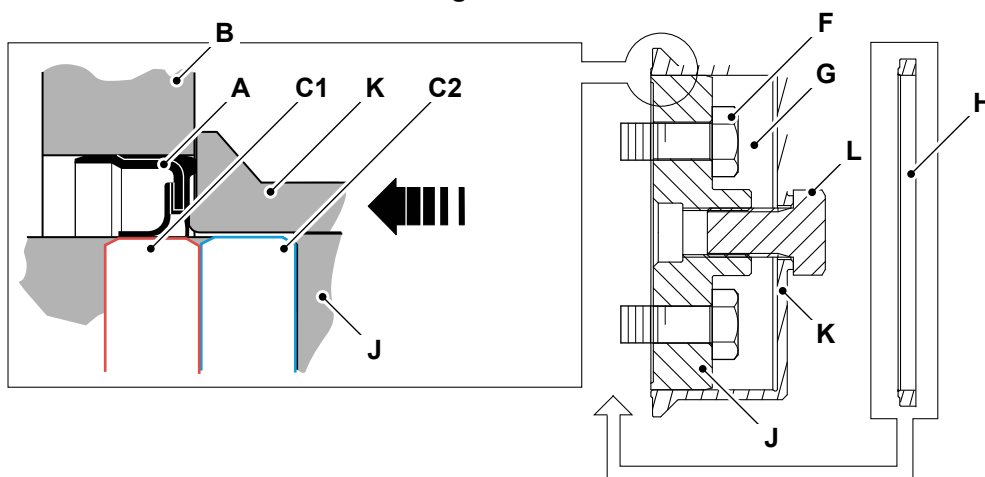

- A** Crankshaft rear oil seal
- C1** New hub
- F** Flywheel bolts
- H** Extension ring
- K** Outer sleeve

- B** Flywheel housing
- C2** Old hub
- G** Oil seal installation tool
- J** Centre body
- L** Screw

6. Turn the screw to push the seal into position in the counterbore so that the screw will not turn.

7. Remove the oil seal installation tool, remove the old hub and install the fixing bolt. Repeat steps 5 and 6 to fully install the rear oil seal.
8. Remove the oil seal installation tool.

### **After Installation**

1. Install the flywheel, refer to (PIL 15-54).

**Table 71. Torque Values**

<b>Item</b>	<b>Nm</b>
E	47



**Suggest:**

**If the above button click is invalid.**

**Please download this document**

**first, and then click the above link**

**to download the complete manual.**

**Thank you so much for reading**

## 12 - Pulley

### Remove and Install

(For: JCB Tier 2/3 Elec Engine 4 Cyl)

#### Special Tools

Description	Part No.	Qty.
Torque Wrench (10-100Nm)	993/70111	1

#### Before Removal

1. This procedure requires service parts. Make sure you have obtained the correct service parts before you start, refer to Parts Catalogue.
2. Make sure that the engine is safe to work on. If the engine has been running, let it cool before you start the service work.
3. Get access to the engine.
4. Remove the drive belt. Refer to (PIL 15-18).

#### Remove

1. Remove the fixing bolts and withdraw the pulley from the crankshaft.

**Figure 148.**

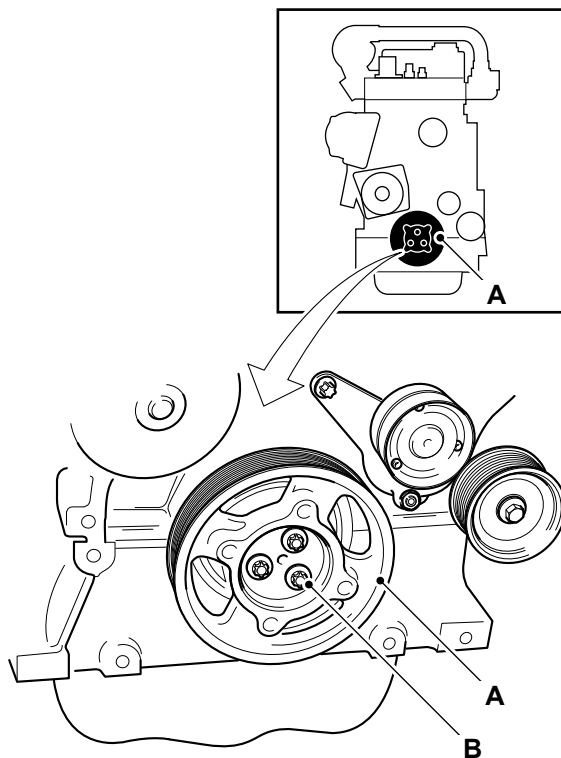

- A Crankshaft pulley
- B Fixing bolts (x3)

2. The bolts must not be reused. Discard the bolts.

#### Install

1. The installation procedure is the opposite of the removal procedure. Additionally do the following steps.
2. Make sure that all items are clean and free from damage and corrosion.
3. Renew the fixing bolts. Tighten the new bolts in three stages to the correct torque value.

**Special Tool: Torque Wrench (10-100Nm) (Qty.: 1)**

4. The bolts are tightened using a torque and angle method. Refer to Fasteners and Fixings, General, Introduction (PIL 72-00).

**Figure 149.**

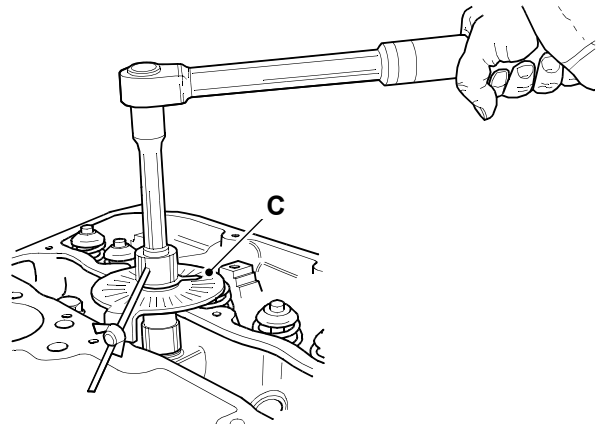

**C** Angle gauge (obtain locally)

#### After Replacement

1. Install the drive belt. Refer to (PIL 15-18).

**Table 72.**

Item	Torque Value (Nm)	Torque Angle (Degrees)
2 (1st stage)	30N·m	
2 (2nd stage)	75N·m	
2 (Final stage)		180°

**<https://www.ebooklibonline.com>**

Hello dear friend!

Thank you very much for reading.

Enter the link into your browser.

The full manual is available for immediate download.

**<https://www.ebooklibonline.com>**