

# SERVICE MANUAL

EXCAVATOR  
210X, 220X

EN - 9813/9600 - ISSUE 2 - 02/2018

This manual contains original instructions, verified by the manufacturer (or their authorized representative).

Copyright 2018 © JCB SERVICE  
All rights reserved. No part of this publication may be reproduced, stored in a retrieval system, or transmitted in any form or by any other means, electronic, mechanical, photocopying or otherwise, without prior permission from JCB SERVICE.

[www.jcb.com](http://www.jcb.com)

## Foreword

### The Operator's Manual

**⚠**  
You and others can be killed or seriously injured if you operate or maintain the machine without first studying the Operator's Manual. You must understand and follow the instructions in the Operator's Manual. If you do not understand anything, ask your employer or JCB dealer to explain it.

Do not operate the machine without an Operator's Manual, or if there is anything on the machine you do not understand.

Treat the Operator's Manual as part of the machine. Keep it clean and in good condition. Replace the Operator's Manual immediately if it is lost, damaged or becomes unreadable.

### Contents

**01 - Machine**

**03 - Attachments, Couplings and Load Handling**

**06 - Body and Framework**

**09 - Operator Station**

**12 - Heating, Ventilating and Air-Conditioning (HVAC)**

**15 - Engine**

**18 - Fuel and Exhaust System**

**21 - Cooling System**

**27 - Driveline**

**30 - Hydraulic System**

**33 - Electrical System**

**72 - Fasteners and Fixings**

**75 - Consumable Products**

**78 - After Sales**

## 00 - General

Introduction ..... 15-39  
Technical Data ..... 15-40

## Introduction

The crankcase is the housing for the crankshaft. The enclosure forms the largest cavity in the engine and is located below the cylinders. It is integral with the cylinder bank and forms an engine block. It has an opening in the bottom to which an oil sump is attached with a gasket and bolted joint.

The crankcase protects the crankshaft and connecting rods from foreign objects it also keeps the engine oil contained and allows the oil to be pressurised and also provide the rigid structure with which to join the engine to the transmission.

**Figure 153.**

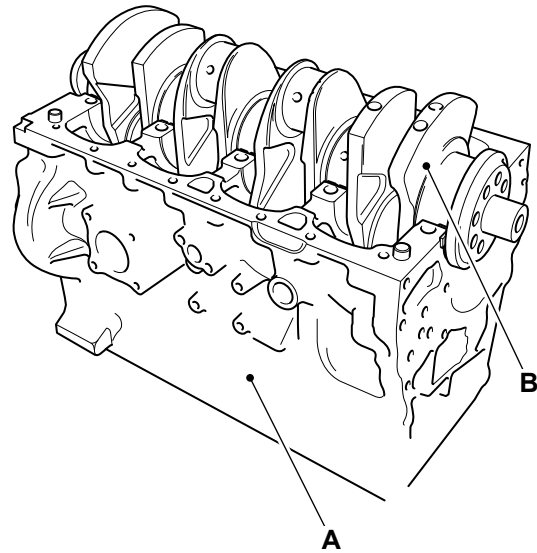

- A** Crankcase
- B** Crankshaft

## Technical Data

**Table 60. Crankcase and Bedplate Data**

	<b>4.4L</b>	<b>4.8L</b>
Cylinder bore <sup>(1)</sup>	103–103.02mm	106–106.02mm
Main bearing bolts torque <sup>(2)</sup>		
First stage	50N·m	50N·m
Second stage	115N·m	115N·m
Final stage	Turn a further 180°	Turn a further 180°
Surface finish for cylinder head joint <sup>(3)</sup>	Rz < 15m, Rmax < 20	Rz < 15m, Rmax < 20
Diameter of first oversize bore	103.5–103.52mm	106.5–106.52mm
Diameter of second oversize bore	104–104.02mm	
Main bearing bore (without bearings)		
Numbers 1 to 4	92–92.02mm	92–92.02mm
Number 5	105–105.02mm	105–105.02mm
Main bearing bore (with bearings)		
Numbers 1 to 4	88.047–88.09mm	88.047–88.09mm
Number 5	100.047–100.09mm	100.047–100.09mm
Camshaft bore		
Numbers 1 to 4	60.04–60.07mm	60.04–60.07mm
Number 5 (bush)	60.29–60.32mm	60.29–60.32mm
Permissible wave profile	wt < 10m (2.5 distance)	wt < 10m (2.5 distance)

(1) Nominal diameter to be measured 63mm below the cylinder head face.

(2) Torque information **MUST** be used in conjunction with the recommended procedures contained in this manual. Failure to use the appropriate and correct removal, replacement, dismantle and assembly procedures may result in an engine failure in service. Refer also to the procedures for the correct bolt tightening sequence.

(3) The crankcase to cylinder head surface may be skimmed and restored using the oversize gaskets (0.25mm and 0.5mm).

**<https://www.ebooklibonline.com>**

Hello dear friend!

Thank you very much for reading.

Enter the link into your browser.

The full manual is available for immediate download.

**<https://www.ebooklibonline.com>**

## Component Identification

Figure 154.

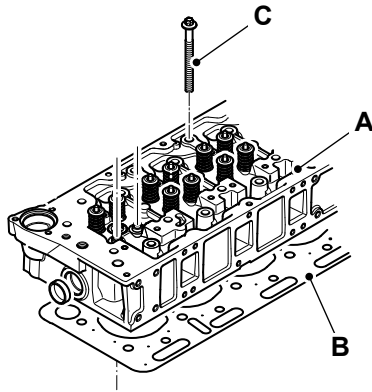

- A Cylinder head
- B Cylinder head gasket
- C Cylinder head bolts

## Remove and Install

### Special Tools

Description	Part No.	Qty.
Torque Wrench (10-100Nm)	993/70111	1

### Consumables

Description	Part No.	Size
Cleaner/Degreaser - General purpose solvent based parts cleaner	4104/1557	0.4L

### Before Removal

1. This procedure requires service parts. Make sure you have obtained the correct parts before you start, refer to Parts Catalogue.
2. Make sure that the engine is safe to work on. If the engine has been running, let it cool before you start the service work.
3. Get access to the engine.
4. Remove the thermostat, refer to (PIL 21-12).
5. Remove the fuel pipes, refer to (PIL 18-96).
6. Remove the rocker cover, refer to (PIL 15-42).
7. Remove the fuel injectors, refer to (PIL 18-18).
8. Remove the rocker assembly, refer to (PIL 15-42).
9. Remove the exhaust manifold, refer to (PIL 18-24).
10. Remove the inlet manifold, refer to (PIL 18-24).

**Figure 155.**

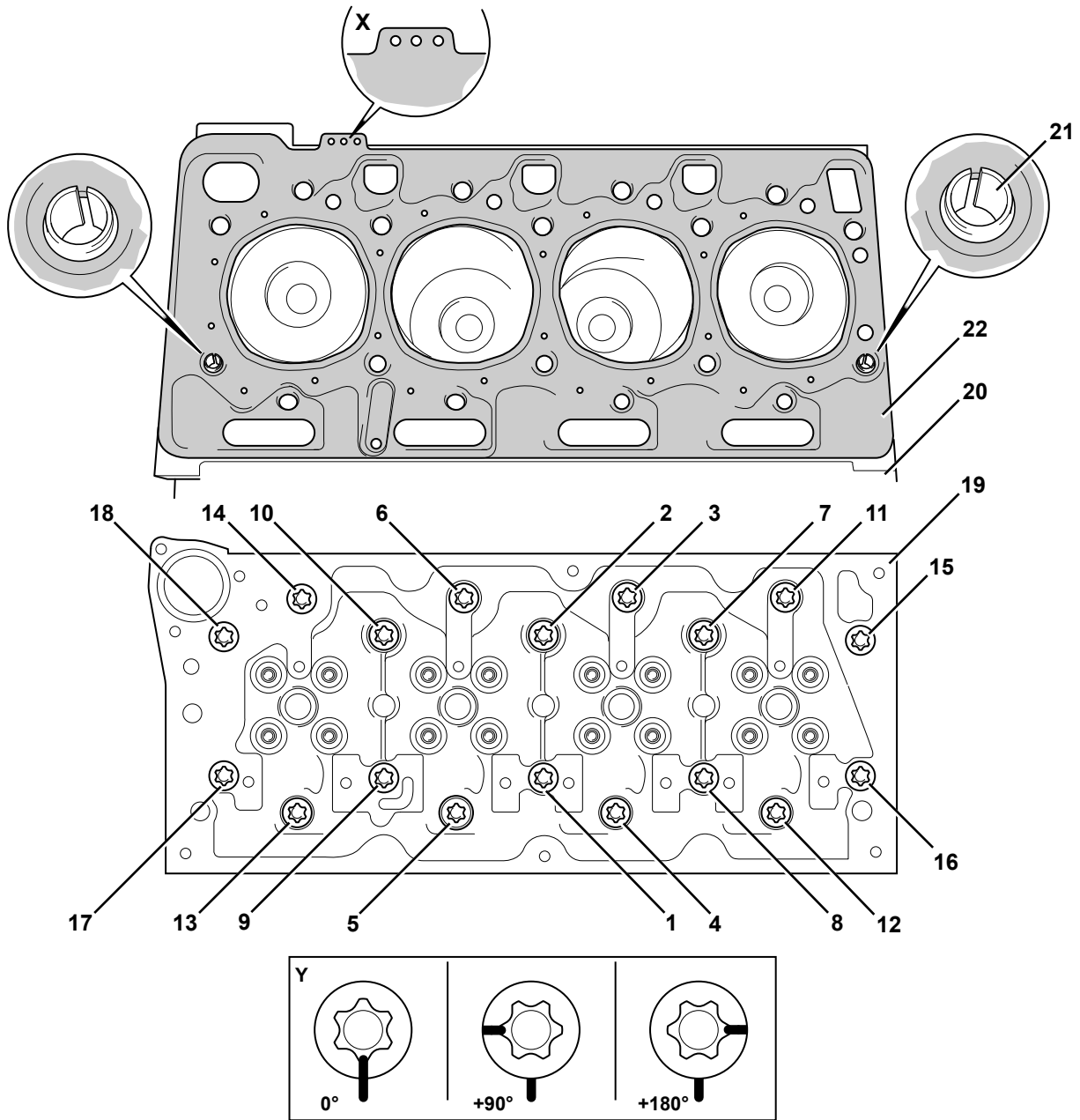

- 1-18** Cylinder head fixing bolts (x18)
- 20** Crankcase
- 22** Cylinder head gasket

- 19** Cylinder head
- 21** Location dowels (x2)

## Remove

1. Progressively remove the cylinder head bolts in reverse order, starting at bolt 18. Note that the bolts **MUST NOT** be re-used. Discard the bolts.
2. Carefully lift the cylinder head from the crankcase. If necessary use a soft face hammer. **DO NOT** use a lever to separate the cylinder head from the crankcase. Discard the head gasket.
3. Using a suitable cleaning agent, carefully remove all traces of the head gasket material from the cylinder head and crankcase mating faces.  
**Consumable: Cleaner/Degreaser - General purpose solvent based parts cleaner**
4. Check the cylinder head and crankcase mating faces for signs of damage and distortion, refer to Technical Data (PIL 15-06).

Special Tool: Torque Wrench (10-100Nm)  
(Qty.: 1)

- 4.2. Then, further tighten the bolts, starting with the middle pair and working outwards (in sequence 1- 18) to the 2nd stage pre-torque.
- 4.3. Then, re-tighten the bolts, starting with the middle pair and working outwards (in sequence 1-18) to the 3rd stage pre-torque.
- 4.4. Use the angle gauge to angle tighten the bolts, starting with the middle pair and working outwards (in sequence 1-18) to the 4th stage pre-torque. As a visual check, matchmark the bolts to the cylinder head before you start. When the bolts have been angle tightened, the matchmarks will appear as shown at Y.
- 4.5. Finally, angle tighten the bolts, starting with the middle pair and working outwards (in sequence 1- 18) for the final stage torque.

## Before Assembly

1. Obtain the correct new cylinder head bolts. Note that the original bolts **MUST NOT** be re-used.
2. Obtain the correct replacement head gasket. Note the number of identification holes as shown at X.
3. Make sure that all items are clean and free from damage and corrosion.

**Table 62.**

Description	Torque Value
Cylinder head to crankcase bolts 1-18	
- first stage torque	40N·m
- second stage torque	75N·m
- third stage torque	75N·m
- fourth stage torque	90°
- final stage torque	180°

## Assemble

The cylinder head bolts are tightened using a torque and angle method, refer to Fasteners and Fixings, General, Introduction (PIL 72-00).

1. Replacement is the reversal of the removal procedure.
2. Make sure that the location dowels are correctly installed into the crankcase. Use a dowel punch to install the dowels as required.
3. Position a new head gasket on to the crankcase mating face. Make sure that the gasket is installed the correct way around and correctly located over the dowels.
4. Lower the cylinder head on to the crankcase. Make sure that the cylinder head is correctly located on the dowels. Install new cylinder head bolts. Tighten the bolts in five stages, use the torque and angle method, refer to Fasteners and Fixings, General, Introduction (PIL 72-00).
  - 4.1. Tighten the bolts, starting with the middle pair and working outwards (in sequence 1-18) to the 1st stage pre-torque.

## 00 - General

[Introduction](#) ..... 15-51  
[Remove and Install](#) ..... 15-52

## Introduction

The bedplate acts as the main strength component of the engine. It maintains the correct alignment and supports the weight of the internal components.

**Figure 156.**

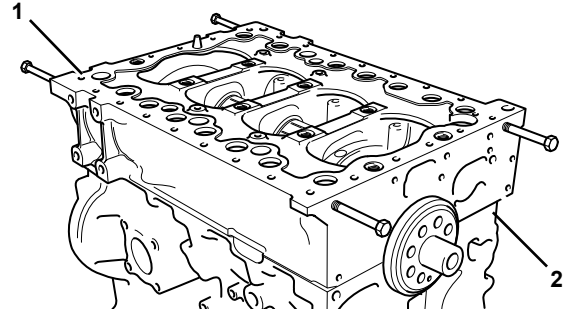

- 1 Bedplate
- 2 Crankcase

## Remove and Install

### Special Tools

Description	Part No.	Qty.
Template for Sealant Bedplate to Crankcase (4 Cyl)	892/12356	1
Torque Wrench (10-100Nm)	993/70111	1

### Consumables

Description	Part No.	Size
Cleaner/Degreaser - General purpose solvent based parts cleaner	4104/1557	0.4L

**▲ CAUTION** This component is heavy. It must only be removed or handled using a suitable lifting method and device.

### Before Removal

- This procedure requires service parts. Make sure you have obtained the correct service parts before you start, refer to Parts Catalogue.
- Make sure that the engine is safe to work on. If the engine has been running, let it cool before you start the service work.
- Remove the engine, refer to (PIL 15-00).
- Remove the drive belt, refer to (PIL 15-18).
- Remove the crankshaft pulley, refer to (PIL 15-12).
- Remove the oil sump, refer to (PIL 15-45).
- Disconnect and remove the fuel pipes from the injectors, refer to (PIL 18-96).
- Remove the rocker cover, refer to (PIL 15-42).
- Remove the fuel injectors, refer to (PIL 18-18).
- Remove the rocker assembly including the push rods, refer to (PIL 15-42).
- It is not necessary to remove the cylinder head assembly to remove the crankshaft. If however the cylinder head needs to be removed for other reasons (for piston and connecting rod removal for example) remove it now, refer to (PIL 15-06).
- Remove the fuel injection pump, refer to (PIL 18-18).
- Remove the starter motor, refer to (PIL 15-75).
- Remove the high duty PTO (Power Take-Off) device (if installed).
- Position the engine upside down in a suitable jig or fixture, supported at the front of the cylinder block.
- Remove the flywheel, refer to (PIL 15-54).
- Remove the flywheel housing, refer to (PIL 15-54).
- Remove the fuel injection pump drive gear, refer to (PIL 15-51).
- Remove the oil pump, refer to (PIL 15-60).
- Remove the high duty PTO idler drive gear (if installed), refer to (PIL 15-51).
- Remove the crankshaft drive gear, refer to (PIL 15-51).
- Remove the camshaft, refer to (PIL 15-15).
- Remove the rear timing case, refer to (PIL 15-51).
- If the pistons and connecting rods have not been removed, undo and remove the main bearing caps, refer to (PIL 15-12).

**Figure 157.**

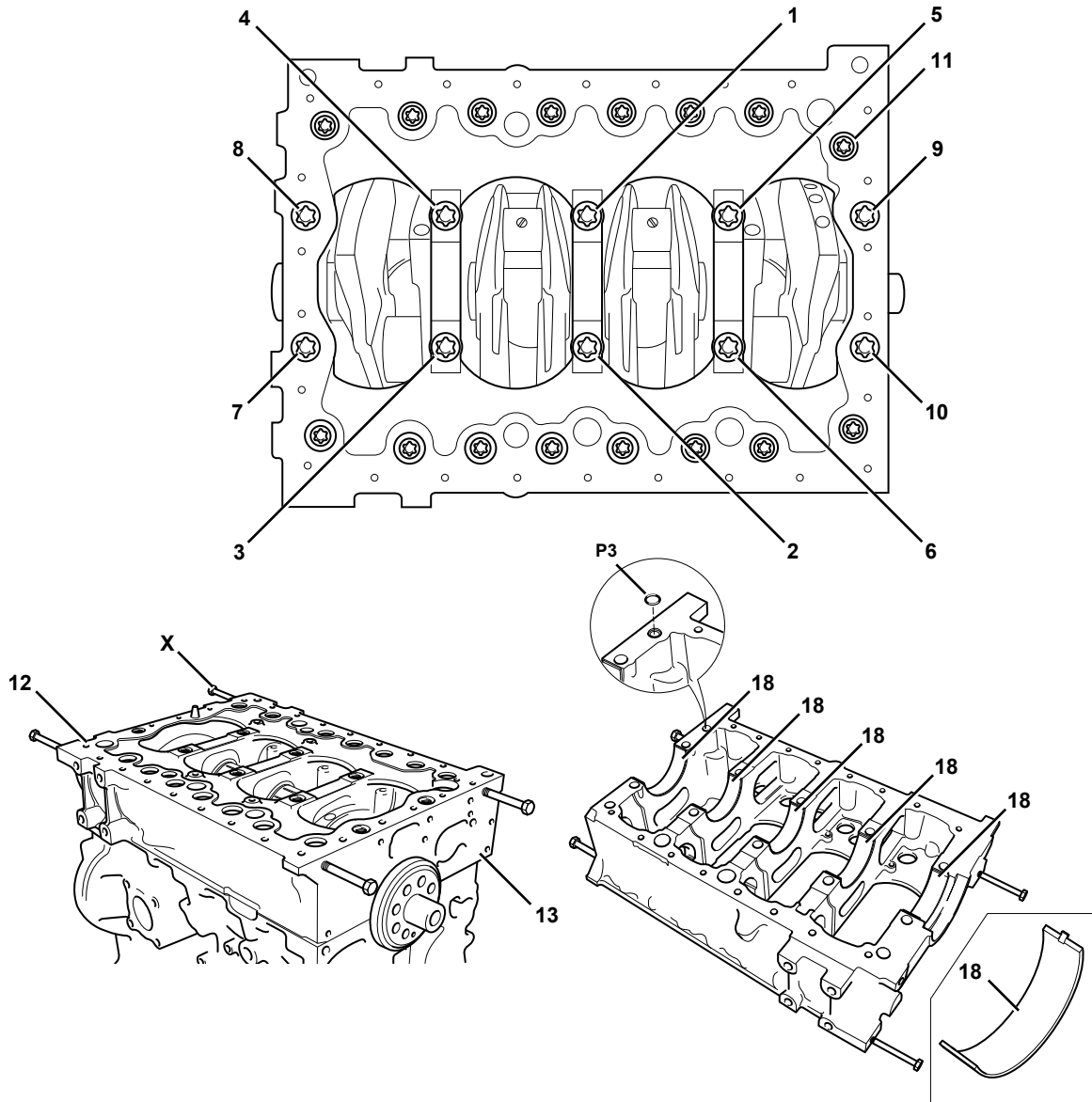

- 1-10** Main bearing bolts (x10)
- 12** Bedplate
- 18** Upper bearing shell (x5)
- T1** Lifting bolts (obtain locally)

- 11** Bedplate peripheral bolts (x16)
- 13** Crankcase
- P3** O-ring (if installed)

**Remove**

1. Remove the bedplate peripheral bolts.
2. Progressively remove the main bearing bolts in reverse order starting at bolt 10. The bolts MUST NOT be re-used. Discard the bolts.
3. Install the four temporary lifting bolts. Carefully separate the bedplate from the crankcase. Use

suitable lifting equipment (if the bedplate is lifted manually, two people will be required). DO NOT use a lever to separate the bedplate.

4. Remove and discard the O-ring.
5. Carefully remove the upper bearing shells from the bedplate, remove the bedplate.

**Figure 158.**

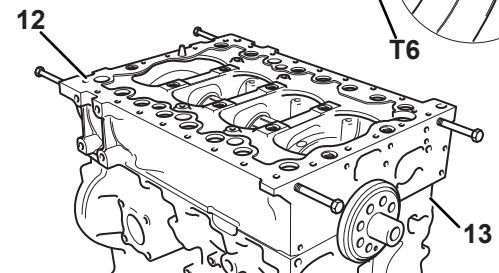
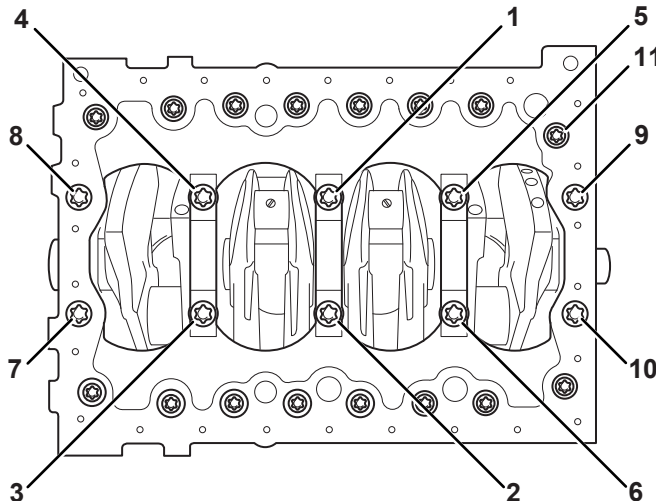
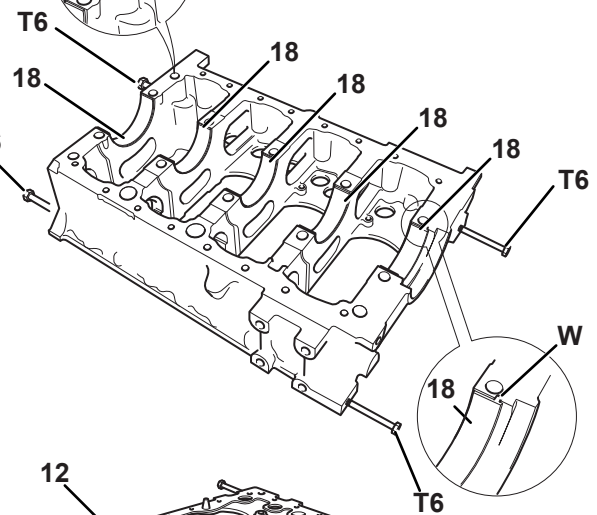
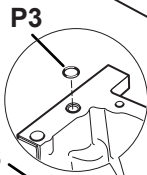
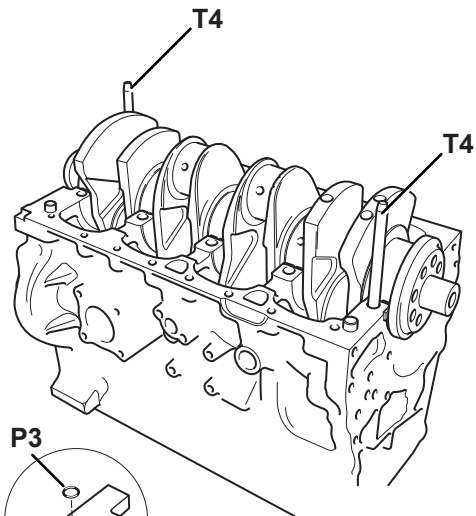
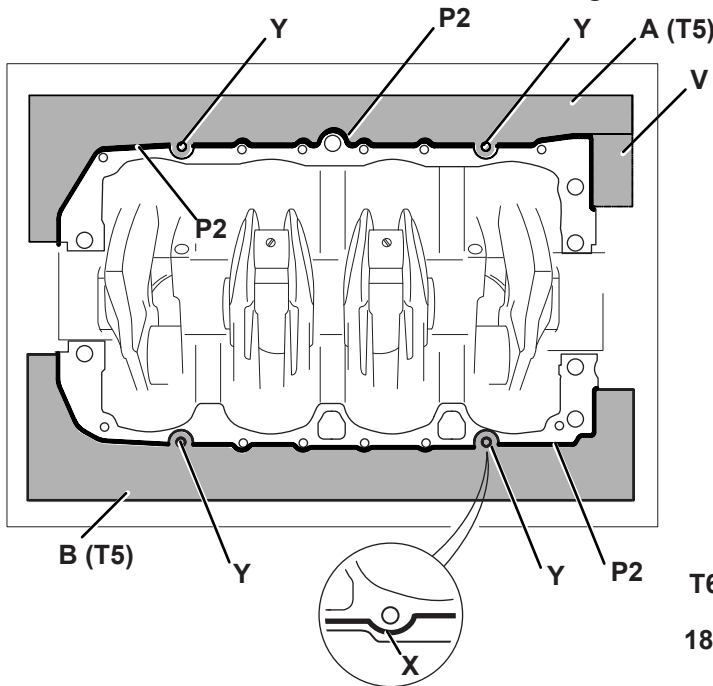

- 1-10 Main bearing bolts
- 12 Bedplate
- 18 Lower bearing shells (x5)
- B Right side template

- 11 Bedplate peripheral bolts (x16)
- 13 Crankcase
- A Left side template
- T3 Angle Gauge (obtain locally)



**T4** Guide pins (x2 obtain locally)  
**T6** Lifting bolts (x4 obtain locally)  
**W** Bearing tab  
**Y** Bearing location tab  
**P3** O-ring

**T5** Sealant template  
**V** Sealant template portion for removal  
**X** Rear main bearing  
**P2** Anaerobic sealant

## Before Installation

1. Clean off all traces of the old sealant compound from the crankcase and bedplate mating faces.
2. Use a suitable degreasing agent to carefully clean the main bearing saddles in the bedplate and crankcase. Take care not to block the oil ways or the piston cooling jets.

**Consumable:** Cleaner/Degreaser - General purpose solvent based parts cleaner

Important: Anaerobic sealant will not start to cure whilst it is open to the atmosphere, however when air is excluded (for instance when the two parts are put together) it will immediately start to harden. Make sure that all the necessary tools, bolts etc. are readily available prior to assembling the components. The parts must be installed and tightened to the correct torque value within 5 minutes (with a maximum permissible time of 15 minutes).

Important: BEFORE installing the bedplate: DO NOT rotate the crankshaft. Make sure that the upper main bearing shells are flush with the bottom face of the crankcase.

## Install

1. The installation procedure is the opposite of the removal procedure. Additionally do the following steps.
2. Make sure that all items are clean and free from damage and corrosion.
3. Install the two guide pins T4 to the crankcase bedplate fixing holes as shown.
4. Install the four lifting bolts T6 to the bedplate as shown.
5. Install a new O-ring at the bedplate.
6. Use a suitable degreasing agent to clean both sides of the lower bearing shells. Assemble the lower bearing shells into the bedplate. Lubricate the lower bearing shells with clean engine oil. Note: Make sure that the location tab W engages in the slot as shown.
7. Note: The sealant template T5 is used on the crankcase, NOT the bedplate. The sealant template T5 comprises of two pieces, A and B. Modify the template A by removing portion V.

**Consumable:** Cleaner/Degreaser - General purpose solvent based parts cleaner

**Special Tool:** Template for Sealant Bedplate to Crankcase (4 Cyl) (Qty.: 1)

8. Locate the holes in the templates A and B using four fixing bolts at positions Y. Use the templates

as a guide apply beads of sealant P2 around the crankcase/bedplate mating face as shown to the dimension specified.

Length/Dimension/Distance: 1.5mm

9. Remove the four fixing bolts at positions Y. Remove the templates A and B, make sure you do not smudge the sealant. Discard the templates.
10. Add beads of sealant P2 around the four bolt holes at positions Y, so as to join the sealant beads as shown at X.
11. Make sure that the location guide pins T4 are in position in the crankcase. Assemble the bedplate to the crankcase use the alignment guide pins.
12. Note: The bedplate is heavy. Two people will be required to lift and rotate the bedplate safely on to the crankcase. Install new main bearing bolts 1-10. Tighten the bolts to the correct torque value in pairs, starting in the centre and working outwards (in sequence 1-10) to the 1st stage pre-torque.

**Special Tool:** Torque Wrench (10-100Nm) (Qty.: 1)

13. Install the bedplate peripheral bolts. Tighten the bolts to the correct torque value.
14. After installation and tightening the bedplate peripheral bolts, further tighten the main bearing bolts in pairs, starting in the centre and working outwards (in sequence 1-10) to the 2nd stage pre-torque.
15. Finally, angle tighten the main bearing bolts in pairs, starting in the centre and working outwards (in sequence 1-10) for the final stage torque. Use the torque and angle method, refer to Fasteners and Fixings, General, Introduction (PIL 72-00).

Important: If the parts have not been tightened to the correct torque value within the maximum 15 minute time period, then the parts must be separated, thoroughly cleaned and fresh sealant applied.

## After Installation

1. Check that the crankshaft can be freely rotated by hand. Remove the bedplate lifting bolts T6.
2. Carry out the procedures listed, Before removal in reverse order.

**Table 63. Torque Table**

Item	Torque Value
1-10 (1st Stage)	50N·m
1-10 (2nd Stage)	115N·m

## Operation

### Lubrication

Oil is fed from the main gallery via five drillings, one to each of the main bearings. A groove around the

diameter of the upper main bearing shell allows oil transfer to cross drillings in the crankshaft to feed each of the big end bearings. Crankshaft gear is 'splash' lubricated. Front and rear crankshaft oil seals prevent oil leakage from, and dirt ingress to, the engine.

Figure 160.

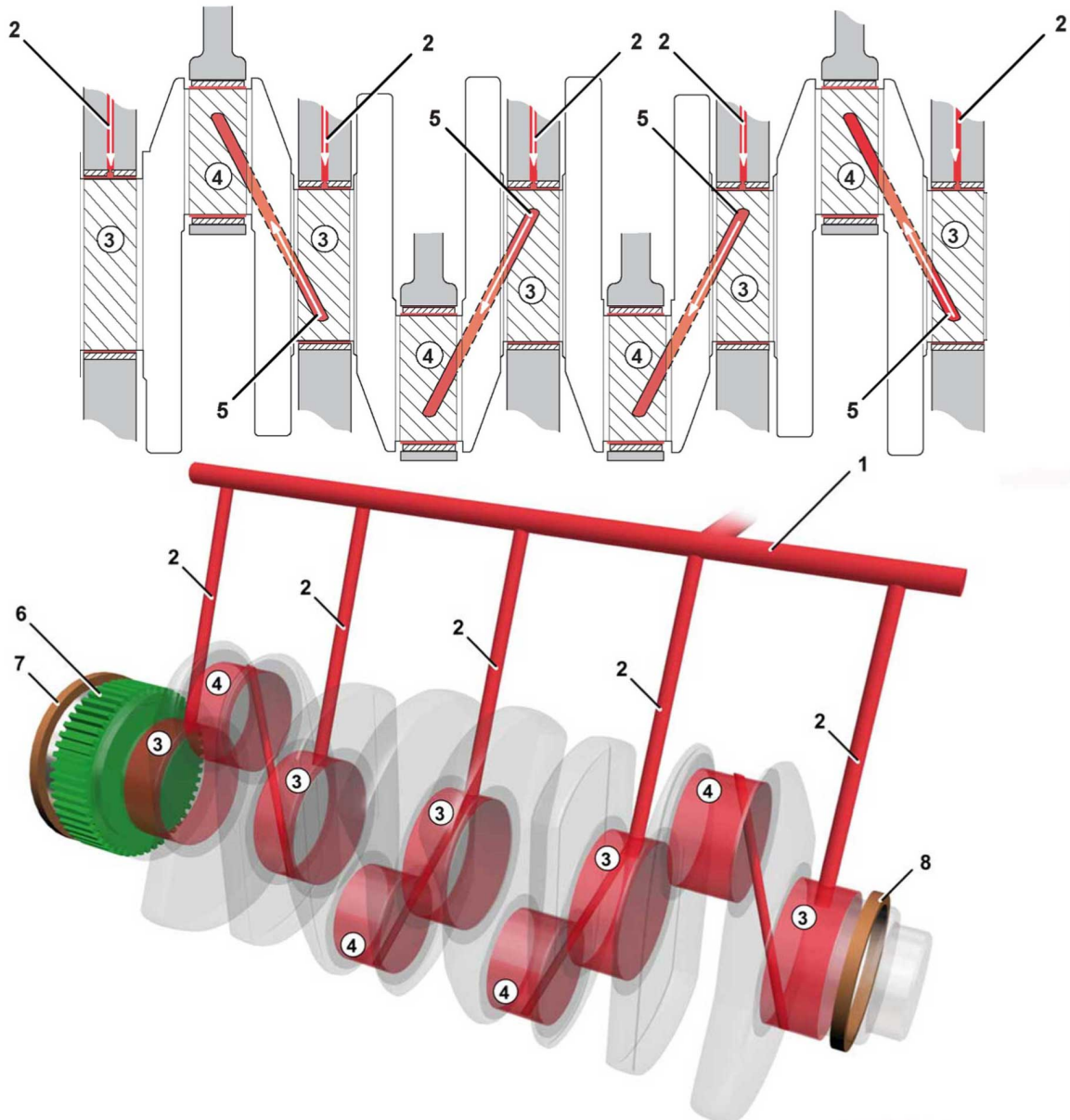

- 1 Main gallery
- 3 Main bearings
- 5 Cross drillings
- 7 Crankshaft oil seal

- 2 Drillings (x5)
- 4 Big end bearings
- 6 Crankshaft gear
- 8 Crankshaft oil seal

## Check (Condition)

1. Check the main bearing surfaces for damage and excessive wear.

**Figure 161.**

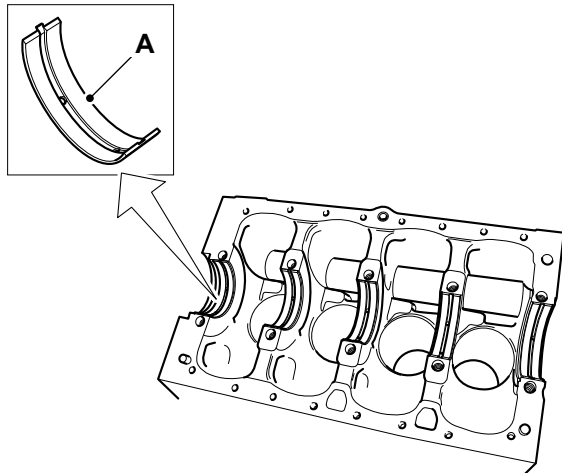

**A** Main bearing shells

2. Measure the crankshaft diameters to confirm they are within service limits, refer to Technical Data (PIL 15-12).

**Figure 162.**

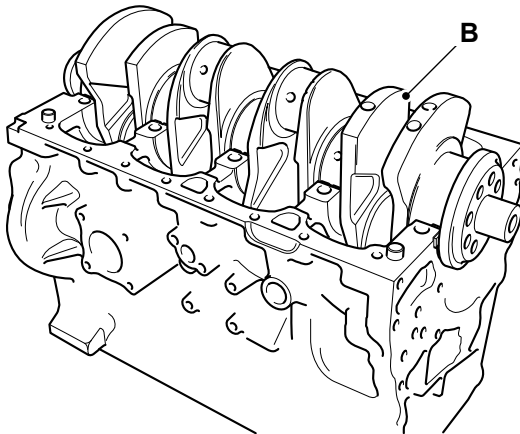

**B** Crankshaft

3. Check that the oil-way cross drillings in the crankshaft are clear and free from debris. Blocked or restricted oil-ways will cause oil starvation at the big end bearings.
4. Check that the piston cooling J-jets are clear. If the J-jets cannot be cleared remove the fixing screws. Remove the J-jets and discard them.
5. Install new J-jets.

**Figure 163.**

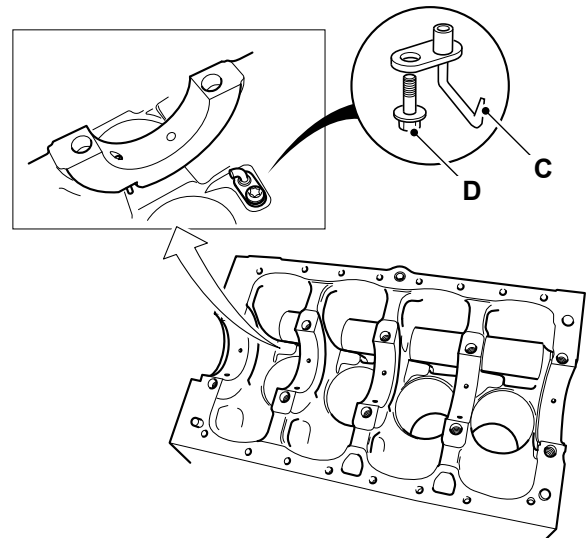

**C** J-jets  
**D** Fixing screws

## Remove and Install

### Consumables

Description	Part No.	Size
Cleaner/Degreaser - General purpose solvent based parts cleaner	4104/1557	0.4L

**▲ CAUTION** This component is heavy. It must only be removed or handled using a suitable lifting method and device.

### Before Removal

1. This procedure requires service parts. Make sure you have obtained the correct service parts before you start, refer to Parts Catalogue.
2. Make sure that the engine is safe to work on. If the engine has been running, let it cool before you start the service work.
3. Remove the engine, refer to (PIL 15-00).
4. Remove the drive belt, refer to (PIL 15-18).
5. Remove the crankshaft pulley, refer to (PIL 15-12).
6. Remove the oil sump, refer to (PIL 15-45).
7. Disconnect and remove the fuel pipes from the injectors, refer to (PIL 18-96).
8. Remove the rocker cover, refer to (PIL 15-42).
9. Remove the fuel injectors, refer to (PIL 18-18).
10. Remove the rocker assembly including the push rods, refer to (PIL 15-42).
11. It is not necessary to remove the cylinder head assembly to remove the crankshaft. If however the cylinder head needs to be removed for other

reasons (for piston and connecting rod removal for example) remove it now, refer to (PIL 15-06).

12. Remove the fuel injection pump, refer to (PIL 18-18).
13. Remove the starter motor, refer to (PIL 15-75).
14. Remove the high duty PTO device (if installed).
15. Position the engine upside down in a suitable jig or fixture, supported at the front of the cylinder block.
16. Remove the flywheel, refer to (PIL 15-54).
17. Remove the flywheel housing, refer to (PIL 15-54).
18. Remove the fuel injection pump drive gear, refer to (PIL 15-51).
19. Remove the oil pump, refer to (PIL 15-60).
20. Remove the high duty PTO idler drive gear (if installed), refer to (PIL 15-51).
21. Remove the crankshaft drive gear, refer to (PIL 15-51).
22. Remove the camshaft, refer to (PIL 15-15).
23. Remove the rear timing case, refer to (PIL 15-51).
24. If the pistons and connecting rods have not been removed, undo and remove the main bearing caps, refer to (PIL 15-12).
25. Remove the bedplate, refer to (PIL 15-09).

### Remove

1. Remove the thrust washers between the crankshaft and crankcase rear main bearing.

**Figure 164.**

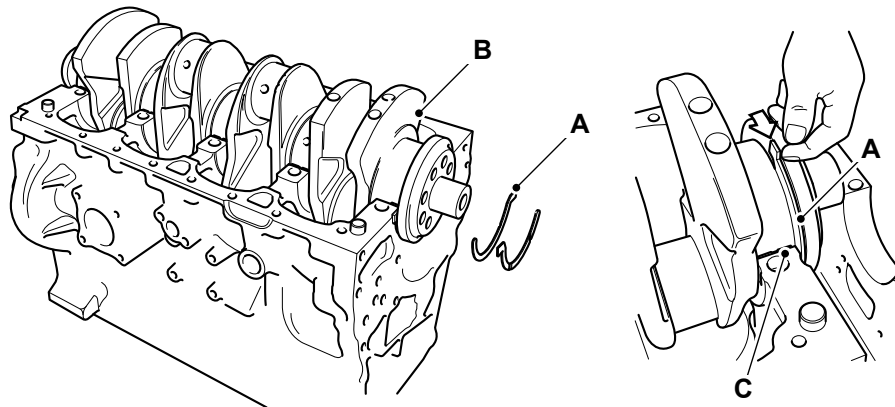

- A** Thrust Washers
- C** Rear main bearing

- B** Crankshaft

2. Put labels on the thrust washers to make sure that they are installed in the correct positions during assembly.
3. Use suitable lifting equipment to carefully lift the crankshaft from the crankcase (if the crankshaft is lifted manually, two people will be required).
4. Carefully lift out the bearing shells.

**Before Installation**

1. Clean off all traces of the old sealant compound from the crankcase and bedplate mating faces.
2. Use a suitable degreasing agent to carefully clean the main bearing saddles in the bedplate and crankcase. Take care not to block the oil ways or the piston cooling jets.

**Consumable:** [Cleaner/Degreaser - General purpose solvent based parts cleaner](#)

**Important:** Cleanliness is of the utmost importance. Blocked oil-ways or oil jets will cause engine failure. Before you install the crankshaft make sure that ALL oil-ways and jets are clear and free from debris.

**Figure 165.**

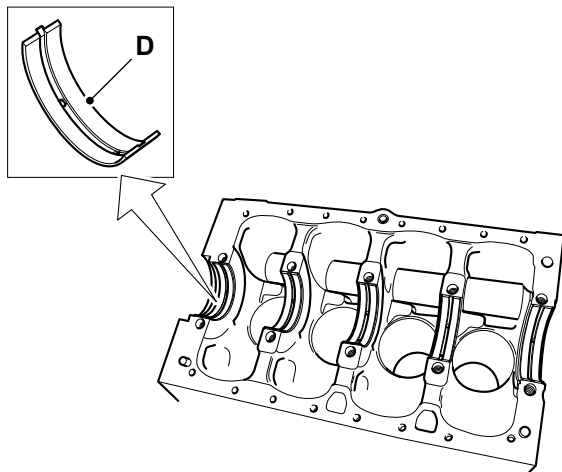

- D** Main bearing shells

5. It is recommended that the bearing shells are replaced. If however they are to be used again, put label on the shells to make sure that they are installed in their original positions during assembly.
6. Inspect the crankshaft and main bearings etc. for damage and excessive wear. Refer to Check Condition (PIL 15-12).

**Install**

1. The installation procedure is the opposite of the removal procedure. Additionally do the following steps.
2. Make sure that all items are clean and free from damage and corrosion.
3. If removed or a new crankcase is being installed then install cooling J jets as follows:

**Figure 166.**

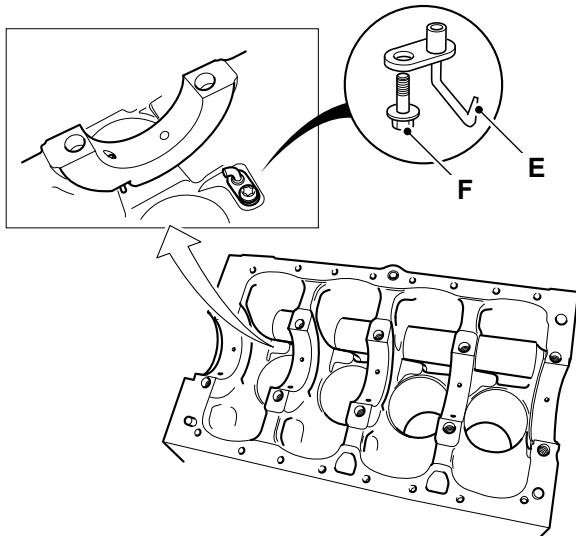

- E** J jets (x4)
- F** Fixing screws

- 3.1. Insert the cooling jets into the crankcase.
- 3.2. Note: There are different types of cooling jets installed depending on the engine application. The jets are colour coded.
- 3.3. Be sure to install the correct jets. Refer to the relevant parts catalogue for the correct cooling jet identification.
- 3.4. Tighten the retaining screws to the correct torque value.

4. Install the upper bearing shells as follows:

**Figure 167.**

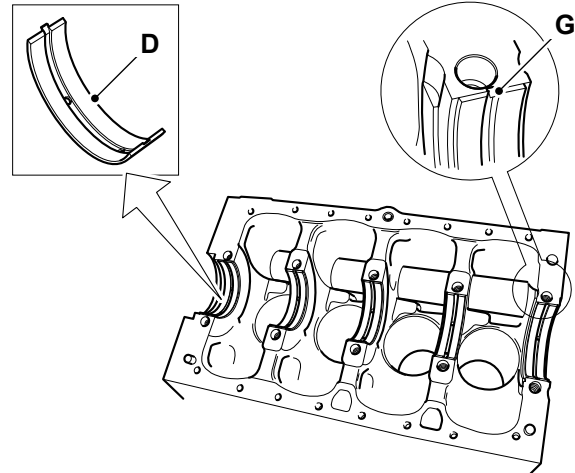

- D** Main bearing shells
- G** Bearing location tab

- 4.1. Use a suitable degreasing agent to make sure that the surface of the upper bearing shells are clean.

[Consumable: Cleaner/Degreaser - General purpose solvent based parts cleaner](#)

- 4.2. Assemble the bearing shells into the crankcase bearing saddles. Make sure that the location tab engages into the slot as shown.
- 4.3. Important: Make sure that the oil-way holes in the bearing saddles align with the holes in the bearing shell. If the holes are even partially misaligned the piston cooling oil jet will be restricted, causing the engine to fail.
- 4.4. Lubricate the upper bearing shells with clean engine oil.
5. Use suitable lifting equipment (if the crankshaft is lifted manually, two people will be required), to carefully lower the crankshaft into the crankcase. DO NOT rotate the crankshaft, the bearing shells can become dislodged, refer to step 4.
6. Install the thrust washers as follows:

**Figure 168.**

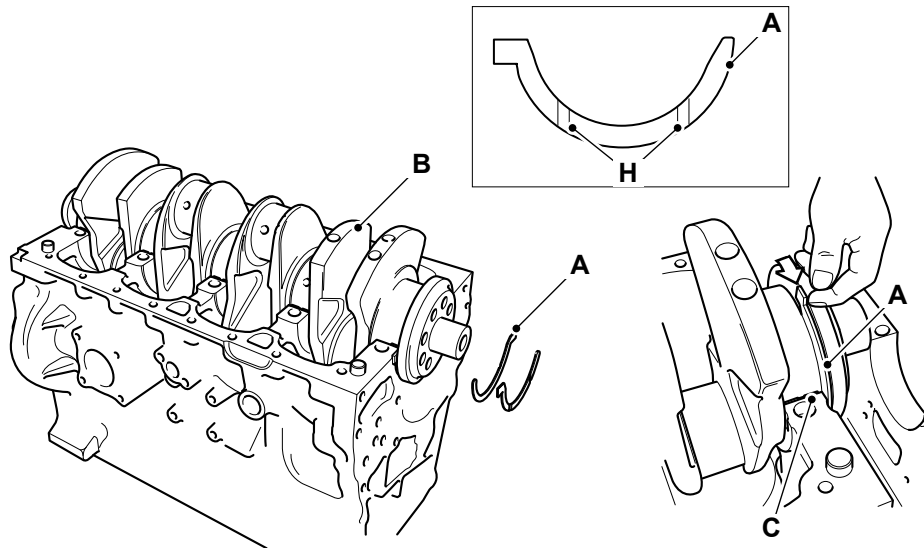

**A** Thrust washers  
**C** Rear main bearing

**B** Crankshaft  
**H** Oil slot - thrust washers

- 6.1. Slide the thrust washers between the crankshaft and the crankcase rear main bearing.
  - 6.2. Make sure that they are installed in the correct positions, with the two slots facing outwards from the bearing saddle.
  - 6.3. If necessary, push the crankshaft forward and then backwards to obtain clearance to install the thrust washers.
  - 6.4. DO NOT rotate the crankshaft, the bearing shells can become dislodged, refer to step 4.
7. Check that the crankshaft end float is within service limits, refer to Technical Data (PIL 15-12).

**Table 65. Torque Values**

Item	Nm
F	24

## 03 - Main Bearing

Introduction .....	15-68
Check (Condition) .....	15-69
Remove and Install .....	15-69

## Introduction

In a piston engine, the main bearings are the bearings on which the crankshaft rotates.

The bearings hold the crankshaft in place and prevent the forces created by the piston and transmitted to the crankshaft by the connecting rods from dislodging the crankshaft, instead forcing the crank to convert the reciprocating movement into rotation.

**Figure 169.**

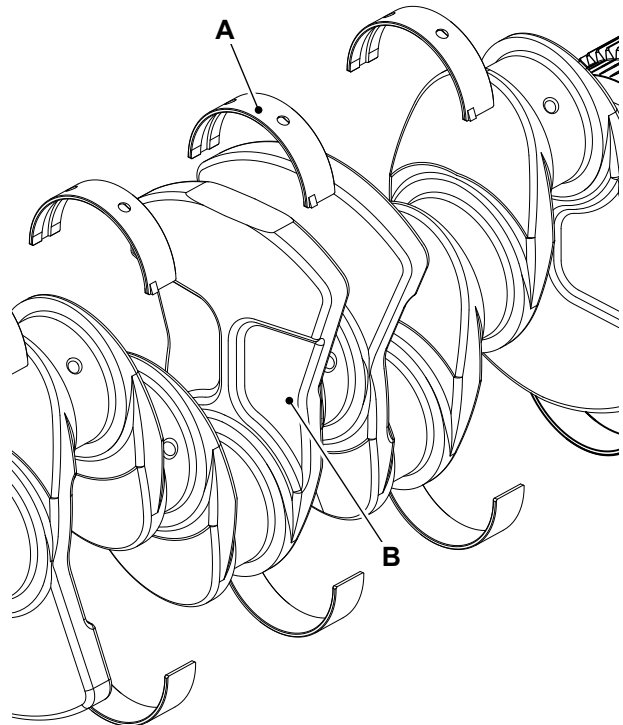

- A** Main bearing
- B** Crankshaft

## Check (Condition)

1. Check the bearing shell surfaces for signs of damage and excessive wear.
2. Measure the crank pin diameters to confirm they are within service limits.  
[Refer to: PIL 15-12-00.](#)
3. Renew any parts that are worn or not within the specified tolerances.

## Remove and Install

[Refer to: PIL 15-12-00.](#)

## 06 - Front Oil Seal

### Remove and Install

#### Special Tools

Description	Part No.	Qty.
Crankshaft Front Oil Seal Installation Tool	892/01157	1

#### Before Removal

1. This procedure requires service parts. Make sure you have obtained the correct service parts before you start, refer to Parts Catalogue.
2. Make sure that the engine is safe to work on. If the engine has been running, let it cool before you start the service work.
3. Get access to the engine.
4. Remove the drive belt, refer to (PIL 15-18).
5. Remove the crankshaft pulley, refer to (PIL 15-12-12).

#### Remove

1. Use a suitable lever behind the lip of the seal, carefully prise out the oil seal from the counterbore in the crankcase. Take care not to scratch or damage the counterbore or the crankshaft hub. Damaged or dirty sealing faces will cause the oil seal to fail.

Figure 170.

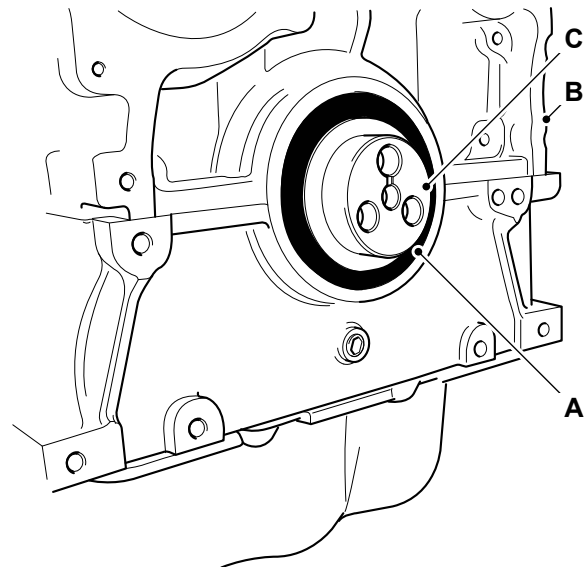

- A Crankshaft oil seal
- B Crankcase
- C Crankshaft hub

#### Install

1. Make sure that the counterbore and the crankshaft hub are clean and free from damage and corrosion. Use a suitable degreasing agent to clean all traces of oil and grease from the counterbore. Important: The oil seal has a special coating and MUST be installed dry without lubricant.
2. Dismantle the seal installation tool. Bolt the centre body to the crankshaft hub, using the bolts. Refer to Figure 171.

**Special Tool: Crankshaft Front Oil Seal Installation Tool (Qty.: 1)**

3. Install the oil seal on to the centre body. Make sure that the seal is installed the correct way around. Assemble the outer sleeve on to the centre body and install the screw. Refer to Figure 171.



**Suggest:**

**If the above button click is invalid.**

**Please download this document**

**first, and then click the above link**

**to download the complete manual.**

**Thank you so much for reading**

**Figure 171.**

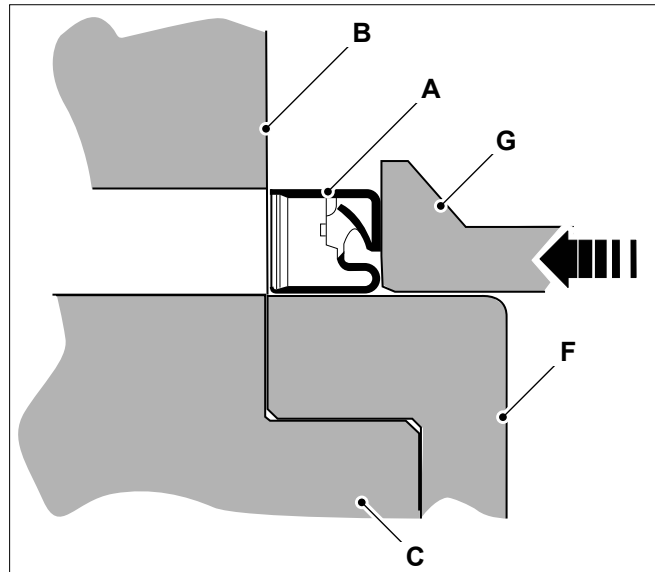
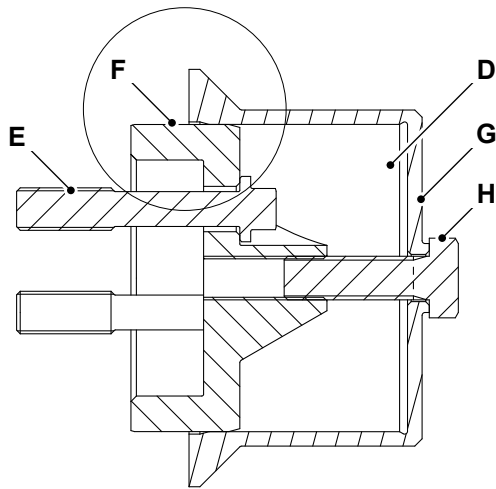

- A** Crankshaft oil seal
- C** Crankshaft hub
- E** Fixing bolts (x3)
- G** Outer sleeve

- B** Crankcase
- D** Seal installation tool
- F** Centre body
- H** Screw

4. Turn the screw to push the seal squarely into the counterbore until the outer sleeve comes up against the front edge of the counterbore. When correctly installed, the front face of the seal should be flush with the edge of the counterbore within the specified tolerance. Refer to Figure 172.

Dimension:  $-0.5 -0/+0.5\text{mm}$

**Figure 172.**

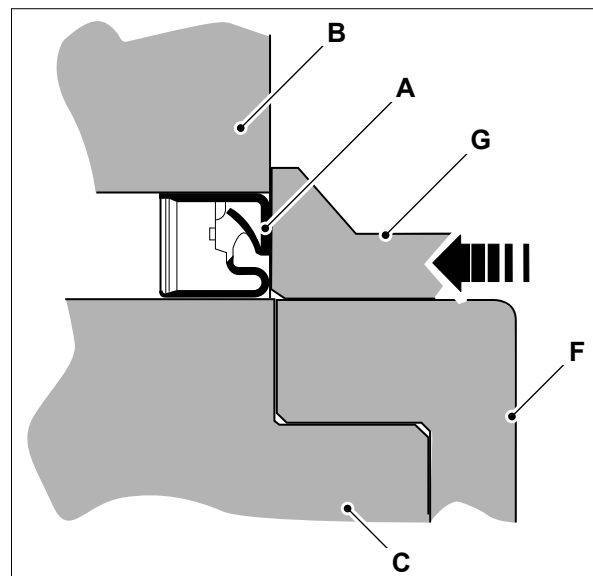

- A** Crankshaft oil seal
- B** Crankcase
- C** Crankshaft hub
- F** Centre body
- G** Outer sleeve

5. Remove the seal installation tool.

**<https://www.ebooklibonline.com>**

Hello dear friend!

Thank you very much for reading.

Enter the link into your browser.

The full manual is available for immediate download.

**<https://www.ebooklibonline.com>**