

SERVICE MANUAL

DUMPER
1T-1 High Tip

EN - 9813/8850 - ISSUE 1 - 07/2018

This manual contains original instructions, verified by the manufacturer (or their authorized representative).

Copyright 2018 Â© JCB SERVICE
All rights reserved. No part of this publication may be reproduced, stored in a retrieval system, or transmitted in any form or by any other means, electronic, mechanical, photocopying or otherwise, without prior permission from JCB SERVICE.

www.jcb.com

Foreword

The Operator's Manual



You and others can be killed or seriously injured if you operate or maintain the machine without first studying the Operator's Manual. You must understand and follow the instructions in the Operator's Manual. If you do not understand anything, ask your employer or JCB dealer to explain it.

Do not operate the machine without an Operator's Manual, or if there is anything on the machine you do not understand.

Treat the Operator's Manual as part of the machine. Keep it clean and in good condition. Replace the Operator's Manual immediately if it is lost, damaged or becomes unreadable.

Contents

01 - Machine

06 - Body and Framework

09 - Operator Station

15 - Engine

18 - Fuel and Exhaust System

21 - Cooling System

24 - Brake System

25 - Steering System

27 - Driveline

30 - Hydraulic System

33 - Electrical System

72 - Fasteners and Fixings

75 - Consumable Products

78 - After Sales

Drain and Fill

▲ CAUTION Oil will gush from the hole when the drain plug is removed. Keep to one side when you remove the plug.

Drain the oil when the engine is warm as contaminants held in suspension will then be drained with the oil.

Drain

1. Make the machine safe.
[Refer to: PIL 01-03-27.](#)
2. Run the engine for the specified duration.
Duration: 5 min
3. Stop the engine.
4. Place a container of suitable size beneath the drain plug.
5. Remove the drain plug.
6. Allow the oil to drain completely.
7. Remove and discard the gasket.
8. Install the drain plug.

Figure 45.

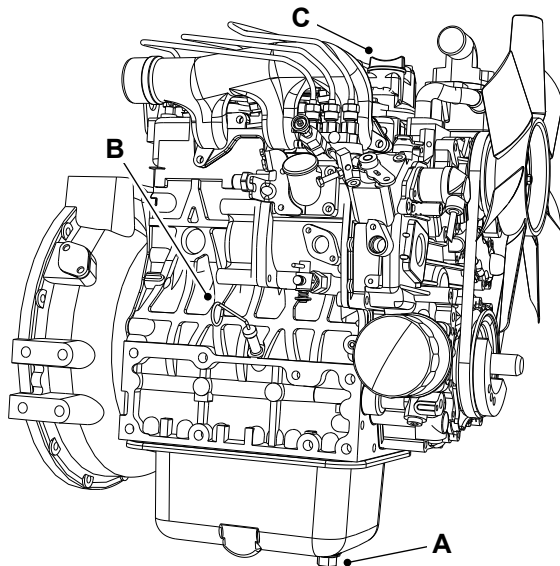

- A** Drain plug
- B** Dipstick
- C** Filler cap

Fill

1. Tighten the drain plug to the correct torque value.
2. Add recommended oil to the engine through the engine filler.

[Refer to: PIL 75-03-03.](#)

3. Check the engine oil level.

Table 26. Torque Values

Item	Description	Nm
A	Drain plug (with Copper gasket)	33–37
A	Drain plug (with Rubber gasket)	45–53

Clean

▲ Notice: Clean the engine before you start engine maintenance. Obey the correct procedures. Contamination of the fuel system will cause damage and possible failure of the engine.

Notice: The engine and other components could be damaged by high pressure washing systems. Special precautions must be taken if the machine is to be washed using a high pressure system.

Make sure that the alternator, starter motor and any other electrical components are shielded and not directly cleaned by the high pressure cleaning system. Do not aim the water jet directly at bearings, oil seals or the engine air induction system.

Before carrying out any service procedures that require components to be removed, the engine must be properly cleaned.

Cleaning must be carried out either in the area of components to be removed or, in the case of major work, or work on the fuel system, the whole engine and surrounding machine must be cleaned.

Stop the engine and allow it to cool for at least one hour. DO NOT attempt to clean any part of the engine while it is running.

1. Make sure that the electrical system is isolated.
2. Make sure that all electrical connectors are correctly coupled. If connectors are open fit the correct caps or seal with water proof tape.
3. Cover the alternator with a plastic bag to prevent water ingress.
4. Seal the engine air intake, exhaust and breather system.
5. Make sure that the oil filler caps and dipstick are correctly installed.
6. Use a low pressure water jet and soft bristle brush to soak off caked mud or dirt.
7. Apply an approved cleaning and degreasing agent with a brush. Obey the manufacturers instructions.
8. Use a pressure washer to remove the soft dirt and oil. Important: DO NOT aim the water jet directly at oil seals or electrical connectors and electronic components such as ECU (Electronic Control Unit)'s, alternator or fuel injectors. DO NOT place the jet nozzle closer than the specified distance to any part of the engine or exhaust system.

Length/Dimension/Distance: 600 mm

9. When the pressure washing is complete move the machine away from the wash area, or alternatively, clean away the material washed from the machine.

10. Before working on specific areas of the engine use a compressed air jet to dry off any moisture. When the area is dry use a soft clean brush to remove any sand or grit particles that remain.

11. When removing components be aware of any dirt or debris that may be exposed. Cover any open ports and clean away the deposits before proceeding.

Additional cleaning must be carried out prior to working on the high pressure fuel system. Refer to: [PIL 18-00-00](#).

<https://www.ebooklibonline.com>

Hello dear friend!

Thank you very much for reading.

Enter the link into your browser.

The full manual is available for immediate download.

<https://www.ebooklibonline.com>

Check (Level)

1. Make the machine safe.
[Refer to: PIL 01-03-27.](#)
2. Make sure that the machine is in a straight and level condition.
3. Open the engine compartment cover.
[Refer to: PIL 06-06-06.](#)
4. Make sure that the engine is safe to work on. If the engine has been running, let it cool before you start the service work.
5. Remove the dipstick.
6. Clean the dipstick.
7. Install the dipstick.
8. Remove the dipstick again.
9. Check that the oil level is between the two marks on the dipstick.
10. If necessary, add recommended oil through one of the filler points.

Figure 46.

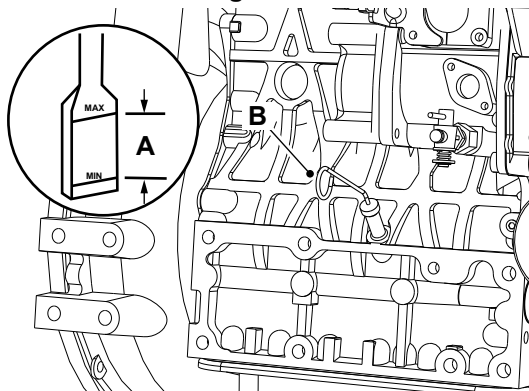

- A** Oil level
B Dipstick

Check (Pressure)

Compression Pressure

This test is used to diagnose suspected poor compression in one or more of the engine cylinders. Use a dummy injector to do the test.

1. Make the machine safe.
[Refer to: PIL 01-03-27.](#)
2. Run the engine until it is warmed up to its operating temperature.
3. Stop the engine.
4. Set a compression tester with the adaptor to the suitable plug hole.
[Refer to: PIL 78-94-14.](#)
5. After making sure that the stop lever is set at the stop position (non-injection), run the engine with the starter and measure the compressor pressure.
6. Repeat the above steps for each cylinder.
7. If the measurement is below the allowable limit, apply a small amount of oil to the cylinder wall through the suitable plug hole and measure the compression pressure again.
8. If the compression pressure is still less than the allowable limit, check the top clearance, valve clearance and cylinder head.
9. If the compression pressure increases after applying oil, check the cylinder wall and piston rings.
10. Check the compression pressure with the specified valve clearance.
11. Always use a fully charged battery for performing this test.
12. Variances in cylinder compression values should be under the specified value.

Percentage: 10 %

Figure 47.

Engine Oil Pressure

1. Make the machine safe.
Refer to: [PIL 01-03-27](#).
2. Remove the engine oil pressure switch, and set an oil pressure tester.
3. Start the engine. After warming up, measure the oil pressure at idle and rated speed.
4. If the oil pressure is less than the allowable limit, check the following:
 - Engine oil insufficient.
 - Oil pump defective.
 - Oil strainer clogged.
 - Oil filter cartridge clogged.
 - Oil gallery clogged.
 - Excessive oil clearance.
 - Foreign matter in the relief valve.

Figure 48.



After checking the engine oil pressure, tighten the engine oil pressure switch to the specified torque value.

Table 27. Torque Values

Item	Description	Nm
1	Oil Pressure switch	17.53

Calibrate

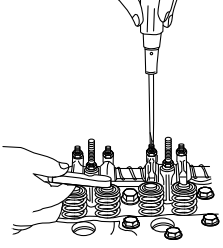
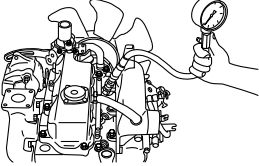
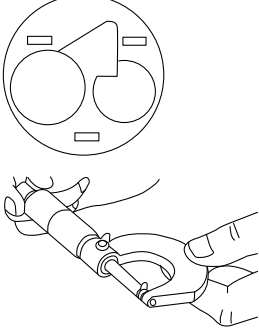
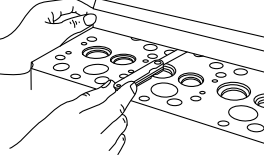
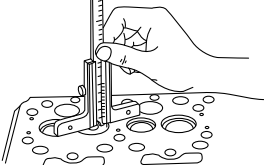
Table 28. Engine Parts Calibration Data

Component		Calibration Data	
Illustration	Description	Factory Specification	Allowable limits
	Cold valve clearance	0.145 –0.185 mm	-
	Compression pressure	37.2 –41.2 bar (539.1 – 597.1 psi) at 290 RPM (Revolutions Per Minute)	22.5 bar (326.1 psi)
		Difference among cylinders	10 % or less
	Top clearance	0.55 –0.7 mm	-
	Cylinder head surface flatness	-	0.05 mm
	Valve recessing	-0.05 –0.25 mm	0.4 mm

Component		Calibration Data	
Illustration	Description	Factory Specification	Allowable limits
	Valve stem to valve guide clearance	0.035 –0.065 mm	0.1 mm
	Valve stem outside diameter	6.96 –6.975 mm	-
	Valve guide inside diameter	7.01 –7.025 mm	-
Valve and valve seat			
	Inlet valve face angle (A)	60 °	-
	Exhaust valve face angle (A)	45 °	-
	Inlet valve seat angle (B)	60 °	-
	Exhaust valve seat angle (B)	45 °	-
	Inlet valve seat width (C)	2.12 mm	-
	Exhaust valve seat width (C)	2.12 mm	-
Valve spring			

Component		Calibration Data	
Illustration	Description	Factory Specification	Allowable limits
	Free length (K)	37 –37.5 mm	36.5 mm
	Tilt (L)	-	1 mm
	Setting load / setting length	117.4 N / 31 mm	100 N / 31 mm
Rocker arm			
	Clearance between rocker arm shaft and rocker arm	0.016 –0.045 mm	0.1 mm
	Rocker arm shaft outside diameter	11.973 –11.984 mm	-
	Rocker arm inside diameter	12 –12.018 mm	-
Push rod			
	Push rod alignment	-	0.25 mm
Valve tappet			
	Clearance between tappet and tappet guide	0.02 –0.062 mm	0.07 mm
	Tappet outside diameter	19.959 –19.98 mm	-
	Tappet guide inside diameter	20 –20.021 mm	-
Timing gear			
	Backlash between crankshaft gear and idler gear 1	0.032 –0.115 mm	0.15 mm
	Backlash between idler gear 1 and camshaft gear	0.036 –0.114 mm	0.15 mm
	Backlash between idler gear 1 and injection pump gear	0.034 –0.116 mm	0.15 mm
	Backlash between idler gear 1 and idler gear 2	0.033 –0.117 mm	0.15 mm
	Backlash between idler gear 2 and governor	0.03 –0.117 mm	0.15 mm
Governor gear	Backlash between governor gear and Injection pump gear	0.03 –0.117 mm	0.15 mm
Idler gear shaft and bushing			
	Clearance between idler gear 1 shaft and idler gear 1 bushing	0.02 –0.054 mm	0.1 mm
	Idler gear 1 shaft outside diameter	25.967 –25.98 mm	-
	Idler gear 1 bushing inside diameter	26 –26.021 mm	-
	Clearance between idler gear 2 shaft and idler gear 2 bushing	0.02 –0.054 mm	0.1 mm

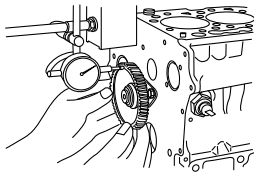
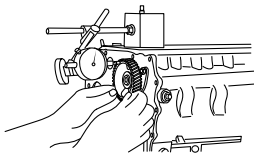
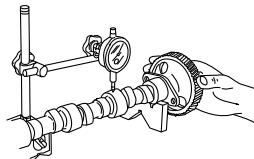
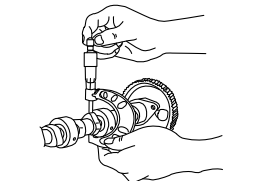
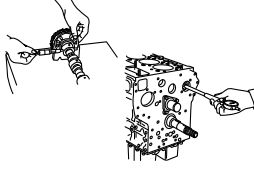
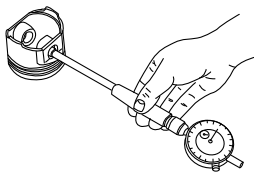
Component		Calibration Data	
Illustration	Description	Factory Specification	Allowable limits
	Idler gear 2 shaft outside diameter	25.967 –25.98 mm	-
	Idler gear 2 bushing inside diameter	26 –26.021 mm	-
Idler gears			
	Idler gear 1 side clearance	0.2 –0.51 mm	0.8 mm
	Idler gear 2 side clearance	0.2 –0.51 mm	0.8 mm
Camshaft			
	Camshaft side clearance	0.07 –0.22 mm	0.3 mm
	Camshaft alignment	-	0.01 mm
Camshaft lobe			
	Camshaft lobe height (In-take)	28.8 mm	28.75 mm
	Camshaft lobe height (Exhaust)	29 mm	28.95 mm
Camshaft journal and crankcase bore			
	Clearance between camshaft journal and crankcase bore	0.05 –0.091 mm	0.15 mm
	Camshaft journal outside diameter	35.934 –35.95 mm	-
	Crankcase bore inside diameter	36 –36.025 mm	-
Piston pin bore			
	Piston pin bore inside diameter	22 –22.013 mm	22.05 mm
Piston rings			

Component		Calibration Data	
Illustration	Description	Factory Specification	Allowable limits
	Clearance between second piston ring groove and second piston ring	0.085 –0.112 mm	0.2 mm
	Clearance between oil ring groove and oil ring	0.02 –0.055 mm	0.15 mm
	Top piston ring gap	0.25 –0.4 mm	1.25 mm
	Second piston ring gap	0.25 –0.4 mm	1.25 mm
	Oil ring gap	0.25 –0.4 mm	1.25 mm
Connecting rod			
	Connecting rod alignment	-	0.05 mm
Piston pin and small end bushing			
	Clearance between piston pin and small end bushing	0.014 –0.038 mm	0.15 mm
	Piston pin outside diameter	22.002 –22.011 mm	-
	Small end bushing inside diameter	22.025 –22.04 mm	-
Crankshaft			
	Crankshaft alignment	-	0.02 mm
Crankshaft journal and crankshaft bearing 1			
	Oil clearance between crankshaft journal and crankshaft bearing 1	0.034 –0.114 mm	0.2 mm
	Crankshaft journal outside diameter	47.934 –47.95 mm	-
	Crankshaft bearing 1 inside diameter	47.984 –48.048 mm	-
Crankshaft journal and crankshaft bearing 2			

Component		Calibration Data	
Illustration	Description	Factory Specification	Allowable limits
	Oil clearance between crankshaft journal and crankshaft bearing 2	0.034 –0.095 mm	0.2 mm
	Crankshaft journal outside diameter	47.934 –47.95 mm	-
	Crankshaft bearing 2 inside diameter	47.984 –48.029 mm	-
Crankshaft journal and crankshaft bearing 3			
	Oil clearance between crankshaft journal and crankshaft bearing 3	0.034 –0.098 mm	0.2 mm
	Crankshaft journal outside diameter	51.921 –51.94 mm	-
	Crankshaft bearing 3 inside diameter	51.974 –52.019 mm	-
Crankpin and crankpin bearing			
	Oil clearance between crankpin and crankpin bearing	0.029 –0.091 mm	0.2 mm
	Crankpin outside diameter	39.959 –39.975 mm	-
	Crankpin bearing inside diameter	40.004 –40.05 mm	-
Crankshaft			
	Crankshaft side clearance	0.15 –0.31 mm	0.5 mm
Cylinder			
	Cylinder bore inside diameter (Standard size)	72 –72.019 mm	72.15 mm
	Cylinder bore inside diameter (Oversize)	72.5 –72.519 mm	72.65 mm

(1) A = Valve face angle, B = Valve seat angle, C = Valve seat width.

(2) D = TDC, E = BDC, F = Inlet valve open, G = Exhaust valve open, H = Exhaust valve close, J = Inlet valve close.

(3) K = Valve spring length, L = Valve spring tilt.

Table 29. Lubrication System Calibration Data

Component		Calibration Data	
Illustration	Description	Factory Specification	Allowable limits
	Engine oil pressure at idle speed	More than 0.49 bar (7.1 psi)	-
	Engine oil pressure at rated speed	1.96 –4.41 bar (28.4 –63.9 psi)	1.47 bar (21.3 psi)

Component		Calibration Data	
Illustration	Description	Factory Specification	Allowable limits
	Clearance between inner rotor and outer rotor	0.06 –0.18 mm	-
	Clearance between outer rotor and pump body	0.1 –0.18 mm	-
	Clearance between inner rotor and cover	0.025 –0.075 mm	-

Table 30. Cooling System Calibration Data

Component		Calibration Data	
Illustration	Description	Factory Specification	Allowable limits
Thermostat			
	Valve opening temperature (At beginning)	69.5 –72.5 °C (157.0 – 162.4 °F)	-
	Valve opening temperature (At completion)	85 °C (184.9 °F)	-
Fan drive belt			
	Fan drive belt tension ⁽¹⁾	7 –9 mm	-

(1) M = Deflection.

Table 31. Fuel System Calibration Data

Component		Calibration Data	
Illustration	Description	Factory Specification	Allowable limits
Fuel injection pump ⁽¹⁾			
	Injection timing (At 3000RPM)	17 –19 ° before TDC (Top Dead Centre)	-
	Injection timing (At 3600RPM)	20 –22 ° before TDC	-
Fuel tightness ⁽²⁾			

Component		Calibration Data	
Illustration	Description	Factory Specification	Allowable limits
	Fuel tightness at pump element	-	137.3 bar (1,989.8 psi)
	Fuel tightness at delivery valve	From 137.3 bar (1,989.8 psi) to 127.5 bar (1,847.8 psi) in 10 s	From 137.3 bar (1,989.8 psi) to 127.5 bar (1,847.8 psi) in 5 s
Injection nozzle			
	Injection nozzle pressure	137.3 –147.1 bar (1,989.8 –2,131.9 psi)	
	Valve seat tightness	When the pressure is 127.5 bar (1,847.8 psi), valve seat must be fuel tight	

(1) N = Timing line, P = Alignment mark.

(2) Q = Injection pump pressure tester, R = Injection nozzle, S = Protection cover for jetted fuel

Table 32. Engine Electrical System Calibration Data

Component		Calibration Data	
Illustration	Description	Factory Specification	Allowable limits
Glow plug resistance		Approximately 0.9 Ω	-
Starter Motor			
	Commutator outside diameter (For: Planetary gear reduction type)	30 mm	29 mm
	Commutator outside diameter (For: Electromagnetic drive type)	28 mm	27 mm
	Difference outside diameter (For: Planetary gear reduction type)	Less than 0.02 mm	0.05 mm
	Difference outside diameter (For: Electromagnetic drive type)	Less than 0.05 mm	0.4 mm
	Mica undercut	0.5 –0.8 mm	0.2 mm
	Brush length	16 mm	10.5 mm
Alternator			
	Stator resistance	Less than 1 Ω	-

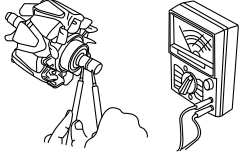
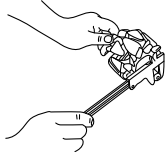
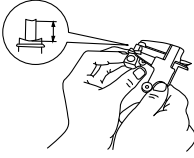
Component		Calibration Data	
Illustration	Description	Factory Specification	Allowable limits
	Rotor resistance	2.9 Ω	-
	Slip ring outside diameter	14.4 mm	14 mm
	Brush length	10 mm	8.4 mm

Remove and Install

▲ CAUTION This component is heavy. It must only be removed or handled using a suitable lifting method and device.

Remove

1. Make the machine safe.
[Refer to: PIL 01-03-27.](#)
2. Isolate the battery.
[Refer to: PIL 33-03-03.](#)
3. Remove the floorplate.
[Refer to: PIL 09-78-00.](#)
4. Remove the engine compartment cover.
[Refer to: PIL 06-06-06.](#)
5. Remove the radiator.
[Refer to: PIL 21-03-03.](#)
6. Remove the air filter assembly.
 - 6.1. Loosen the clamps 1.
 - 6.2. Disconnect the air inlet hoses.
 - 6.3. Remove the bolt 1.

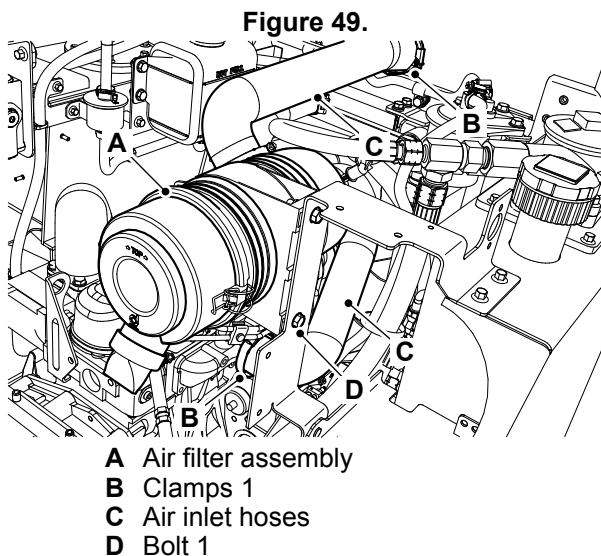

7. Remove the expansion tank.
[Refer to: PIL 21-06-00.](#)
8. Remove the fuel filter.
 - 8.1. Disconnect the fuel pipe from the filter.
 - 8.2. Remove the bolt 2 and nut 1.

Figure 50.

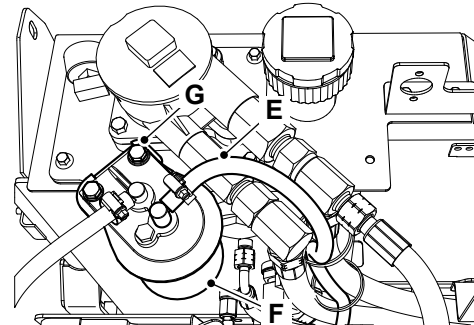

E Fuel hoses
F Fuel filter
G Bolt 2

9. Disconnect the electrical connections from the alternator.
[Refer to: PIL 15-72-00.](#)
10. Disconnect the electrical connections from the starter motor.
[Refer to: PIL 15-75-00.](#)
11. Working underneath the machine, remove the exhaust clamp and disconnect the exhaust pipe.

Figure 51.

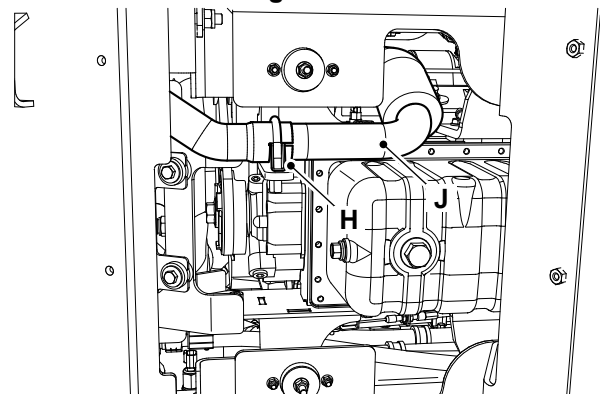

H Exhaust clamp
J Exhaust pipe

12. Remove the heat shield from the exhaust pipe.
13. Remove the bolt 3 from the exhaust pipe.
14. Remove the exhaust pipe from the machine.

Figure 52.

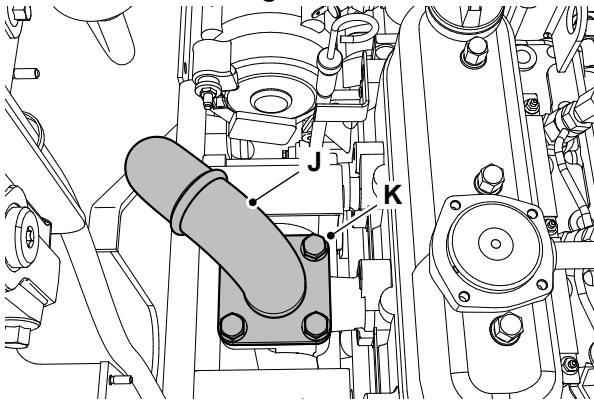

J Exhaust pipe
K Bolt 3

15. Disconnect the fuel pipes.
16. Disconnect the throttle cable.

Figure 53.

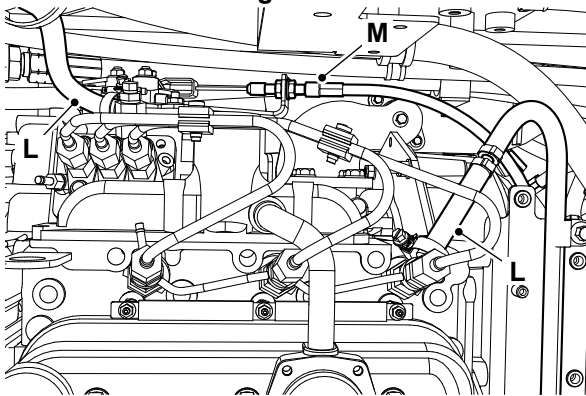

L Fuel pipes
M Throttle cable

17. Remove the wheel drive pump.
[Refer to: PIL 27-31-00.](#)
18. Support the engine with suitable lifting equipment at the engine lifting eye.

Figure 54.

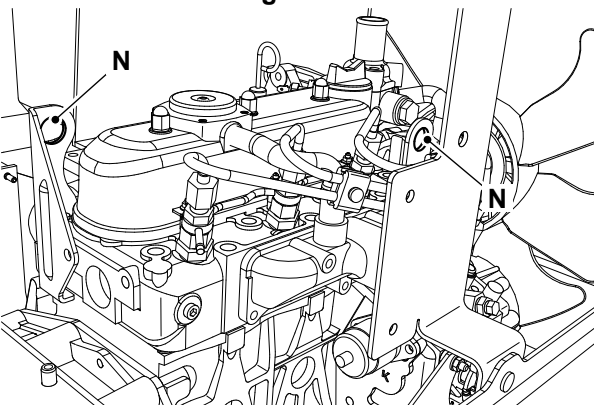

N Lifting eye

19. Remove the nut and bolts from the engine mounts.
20. Slowly remove the engine from the machine.

Figure 55.

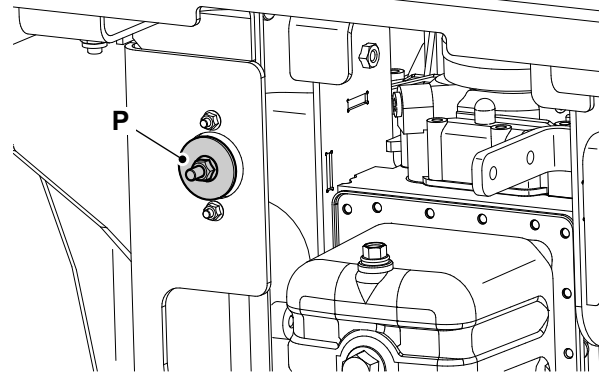

P Engine mounts

Install

1. The installation procedure is the opposite of the removal procedure.



Suggest:

If the above button click is invalid.

Please download this document

first, and then click the above link

to download the complete manual.

Thank you so much for reading

Disassemble and Assemble

Disassemble

1. Make the machine safe.
[Refer to: PIL 01-03-27.](#)
2. Drain the coolant.
[Refer to: PIL 21-00-00.](#)
3. Drain the engine oil.
[Refer to: PIL 15-00-00.](#)
4. Disconnect all the hoses and electrical connectors from the engine.
 - 4.1. Put a label on the hoses and electrical connectors to help installation.
 - 4.2. Plug all the open ports and hoses to prevent contamination.
5. Remove the air filter assembly.
[Refer to: PIL 15-24-00.](#)
6. Remove the engine from the machine.
[Refer to: PIL 15-00-00.](#)
7. Remove the fan belt.
[Refer to: PIL 15-18-06.](#)
8. Remove the alternator.
[Refer to: PIL 15-72-00.](#)
9. Remove the starter motor.
[Refer to: PIL 15-75-00.](#)
10. Remove the turbocharger (if installed).
[Refer to: PIL 18-35-00.](#)
11. Remove the cylinder head cover.
[Refer to: PIL 15-42-06.](#)
12. Remove the fuel injections pipes.
[Refer to: PIL 18-96-03.](#)
13. Remove the injector seal.
[Refer to: PIL 18-18-07.](#)
14. Remove the rocker arm.
[Refer to: PIL 15-42-01.](#)
15. Remove the cylinder head.
[Refer to: PIL 15-06-00.](#)
16. Remove the valve tappets.
[Refer to: PIL 15-42-21.](#)

17. Remove the valves.
[Refer to: PIL 15-30-00.](#)
18. Remove the thermostat.
[Refer to: PIL 21-12-00.](#)
19. Remove the fan drive pulley.
[Refer to: PIL 15-18-27.](#)
20. Remove the timing gear case.
[Refer to: PIL 15-51-00.](#)
21. Remove the boost compensator (if installed).
[Refer to: PIL 18-35-21.](#)
22. Remove the speed control plates.
[Refer to: PIL 18-18-21.](#)
23. Remove the injection pump.
[Refer to: PIL 18-18-15.](#)
24. Remove the camshaft gear, idle gears and governor gear.
[Refer to: PIL 15-51-00.](#)
25. Remove the oil sump.
[Refer to: PIL 15-45-00.](#)
26. Remove the connecting rod.
[Refer to: PIL 15-33-00.](#)
27. Remove the piston.
[Refer to: PIL 15-36-00.](#)
28. Remove the piston rings.
[Refer to: PIL 15-36-00.](#)
29. Remove the flywheel.
[Refer to: PIL 15-54-00.](#)
30. Remove the crankshaft and the main bearings.
[Refer to: PIL 15-12-00.](#)

Assemble

1. The assembly procedure is the opposite of the disassembly procedure. Additionally do the following steps.
2. Check the condition of each component.
3. Tighten all the fasteners to the correct torque value.

<https://www.ebooklibonline.com>

Hello dear friend!

Thank you very much for reading.

Enter the link into your browser.

The full manual is available for immediate download.

<https://www.ebooklibonline.com>