



Service Repair Manual

Models

324D L and 324D LN Excavator

Disassembly Procedure

Table 1

Required Tools			
Tool	Part Number	Part Description	Qty
A	1P-2420	Transmission Repair Stand	1
B	138-7573	Link Bracket	2
C	1P-1863	Retaining Ring Pliers	1
D	194-3878	Spanner Socket	1
E	138-7574	Link Bracket	2
F	5F-7366	Forcing Screw	1
	1P-5546	Crossblock	1
	1U-9889	Crossblock	1
	1P-0520	Driver Group	1
	6V-7888	Puller Leg	2
	1H-3112	Puller Assembly	1
	1P-5551	Adjustable Screw Assembly	1
G	1U-7600	Slide Hammer Puller Gp	1
	8T-0266	Bolt	1

Start By:

- a. Remove the final drive. Refer to Disassembly and Assembly, "Final Drive - Remove".

Note: Cleanliness is an important factor. Before the disassembly procedure, the exterior of the component should be thoroughly cleaned. This will prevent dirt from entering the internal mechanism.

Note: Some of the images that are in this procedure do not show the sprocket assembly that is attached to the final drive housing. If necessary, the weights that are given include the weight of the sprocket assembly.

1. Put an alignment mark across the sections of the final drive for assembly purposes. The parts must be reinstalled in the part's original locations.
-



Illustration 1

g00708089

2. Fasten the final drive to Tooling (A), as shown. The weight of the final drive assembly is approximately 312 kg (688 lb).
3. Remove bolts (1) and the washers that hold the cover in position.

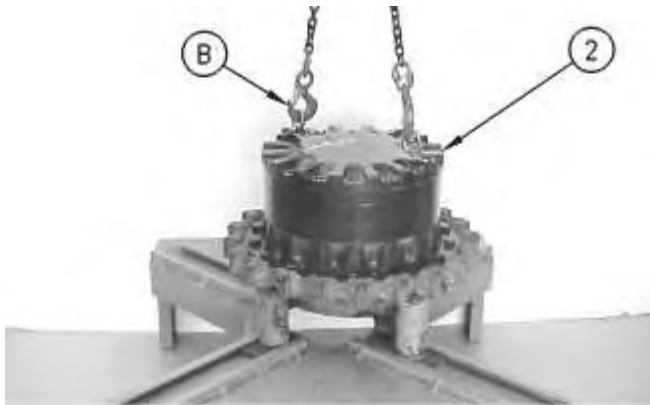

Illustration 2

g00708090

4. Remove the setscrews from the cover. Fasten Tooling (B) and a suitable lifting device to cover (2), as shown. Remove the cover. The weight of the cover is approximately 32 kg (70 lb).

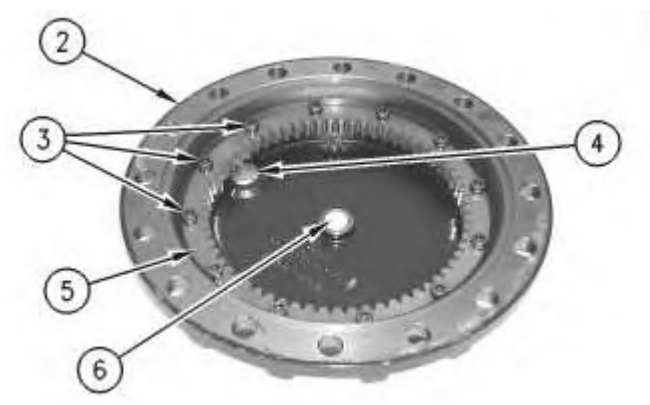

Illustration 3

g00879362

<https://www.ebooklibonline.com>

Hello dear friend!

Thank you very much for reading.

Enter the link into your browser.

The full manual is available for immediate download.

<https://www.ebooklibonline.com>

5. Remove bolts (3). Remove gear (5). Check plate (6). Replace plate (6) if wear is shown. Remove plugs (4) from cover (2).

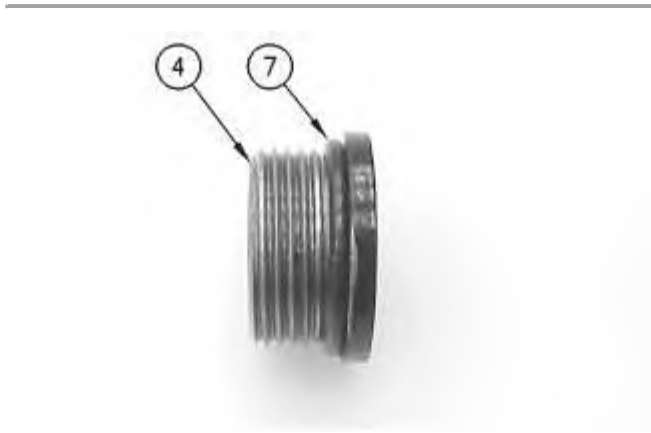

Illustration 4

g00879365

6. Remove O-ring seal (7) from plugs (4).

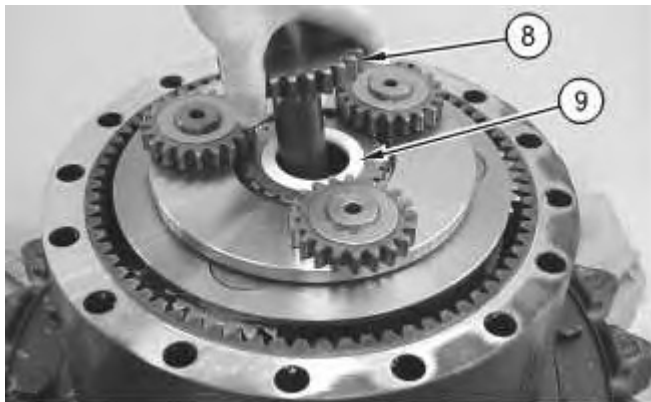

Illustration 5

g00780428

7. Remove gear (8). Remove spacer (9).



Illustration 6

g00780432

8. Remove retaining ring (10) with Tooling (C). Remove washer (11). Remove gear (12). Remove bearing assembly (13). Remove second washer (11).
9. Repeat Step 8 for the remaining two gear assemblies.

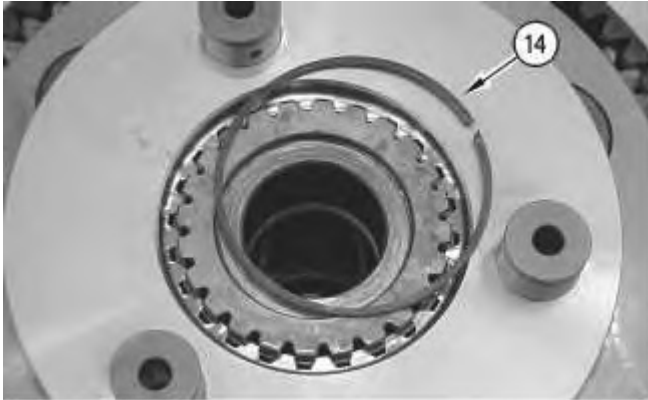

Illustration 7

g00781401

10. Remove retaining ring (14).



Illustration 8

g00781407

11. Remove carrier assembly (15).
-

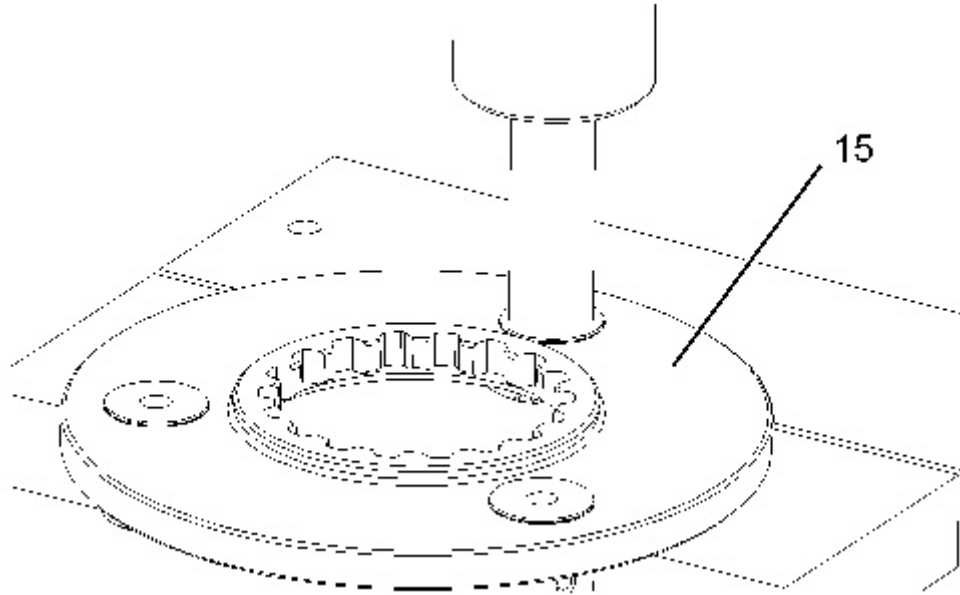

Illustration 9

g01389593

12. Use a suitable press in order to remove the shafts from carrier assembly (15).

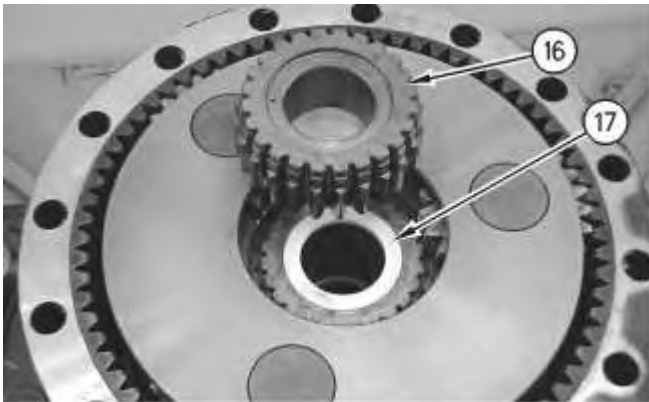

Illustration 10

g00781412

13. Remove gear (16). Remove spacer (17).



Illustration 11

g00781466

14. Remove retaining ring (18).

15. Remove carrier assembly (19).

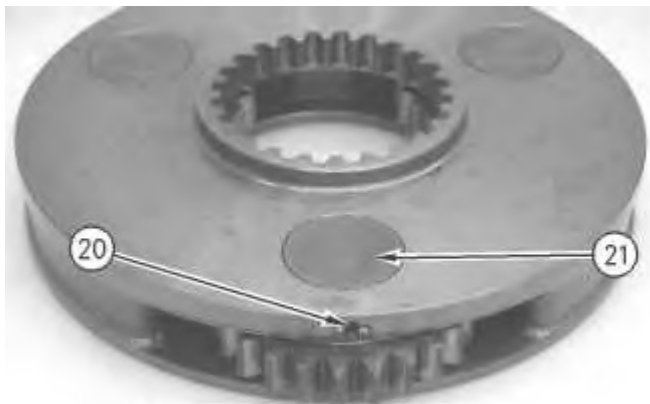

Illustration 12

g00879368

16. Disassemble carrier assembly (19), as follows.

a. Drive spring pin (20) into planetary shaft (21) with a hammer and a punch.

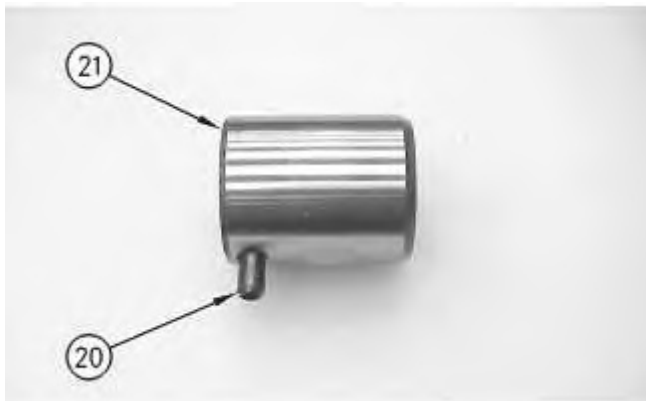
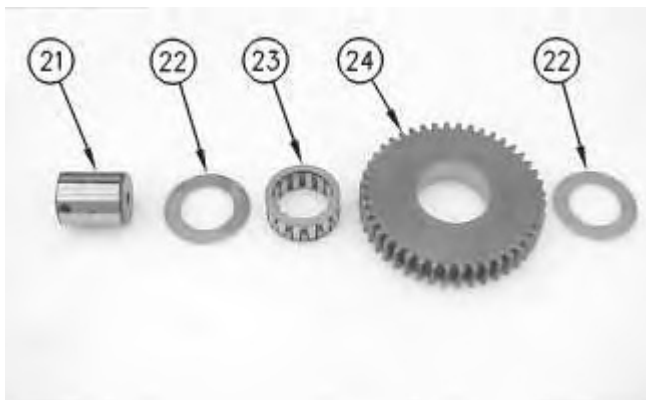

Illustration 13

g00781476

b. Remove planetary shaft (21).

c. Remove spring pin (20) from planetary shaft (21) with a hammer and a punch.



- d. Remove thrust washers (22) and planetary gear (24) from the carrier assembly.
 - e. Remove bearing (23) from planetary gear (24).
17. Repeat Steps 16.a through 16.e for the other two planetary.

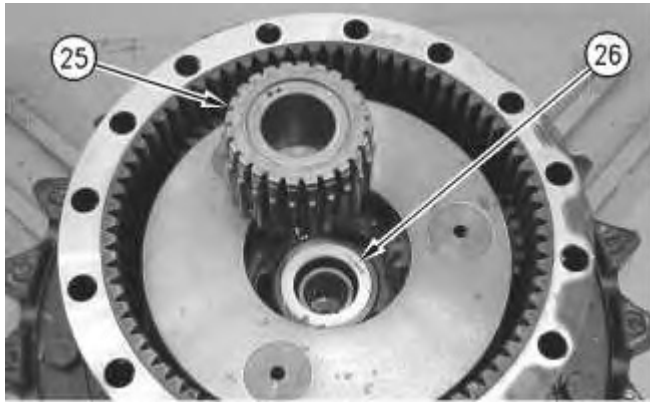

Illustration 15

g00781529

18. Remove gear (25). Remove spacer (26).

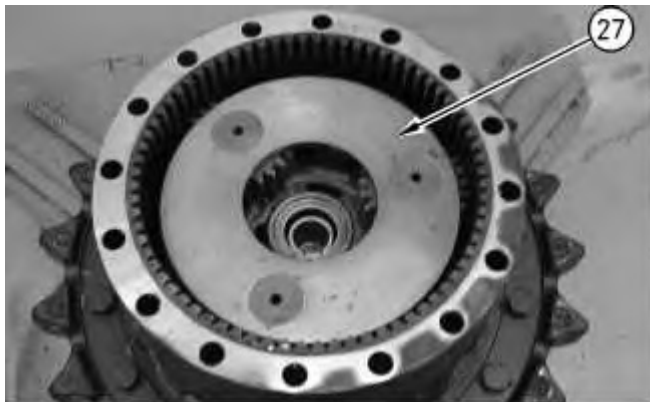

Illustration 16

g00781559

19. Remove carrier assembly (27).
20. Use two people to remove carrier assembly (27). The weight of the carrier assembly is approximately 38 kg (85 lb).
21. Disassemble carrier assembly (27), as follows.



Illustration 17

g00781719

- a. Drive spring pin (29) into planetary shaft (28) with a hammer and a punch.



Illustration 18

g00781601

- b. Remove planetary shaft (28).
- c. Remove spring pin (29) from planetary shaft (28) with a hammer and a punch.

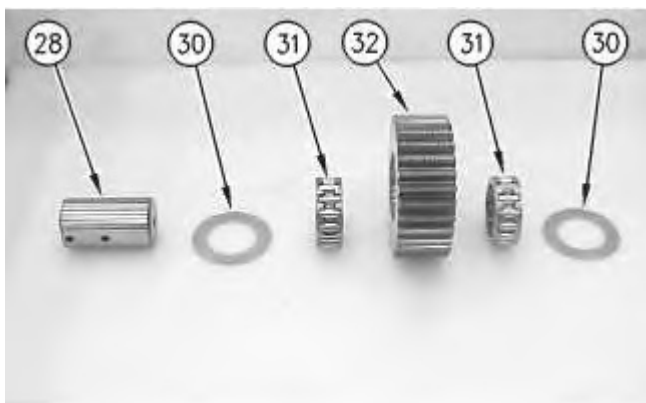

Illustration 19

g00781607

- d. Remove thrust washers (30) and planetary gear (32) from the carrier assembly.
- e. Remove two bearings (31) from the planetary gear.

22. Repeat Steps 21.a through 21.e for the other two planetary gears.



Illustration 20

g00781730

23. Use two people to remove gear (33). The weight of gear is approximately 41 kg (90 lb).



Illustration 21

g00781807

24. Remove O-ring seal (34).



Illustration 22

g01147650

25. Remove bolts (35A) and plates (35B).

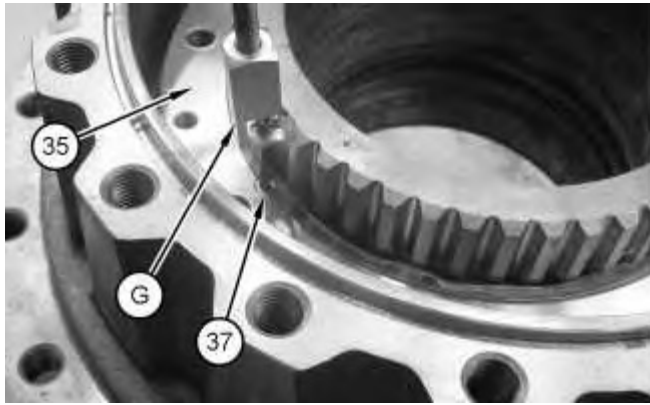

Illustration 23

g01147651

26. Use Tooling (G) to remove dowel (37) from stopper plate (35).

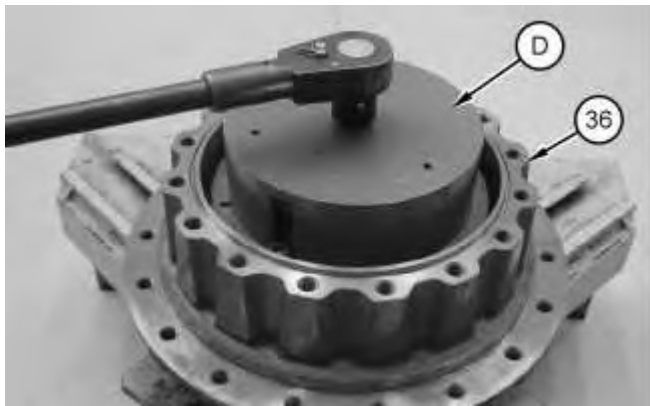

Illustration 24

g01147759

27. Secure Tooling (D) to stopper plate (35). Use Tooling (D) to remove stopper plate (35).



Illustration 25

g01147930

28. Use Tooling (E) and a suitable lifting device to remove housing (36). The weight of housing (36) is approximately 100 kg (220 lb).

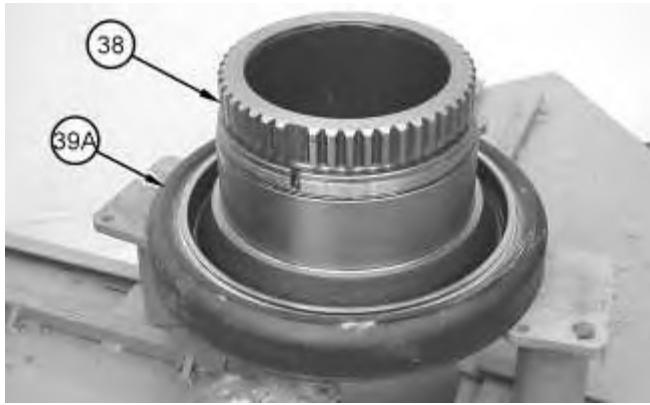

Illustration 26

g01147951

29. Remove Duo-Cone seal (39A) from housing (38).



Illustration 27

g01147975

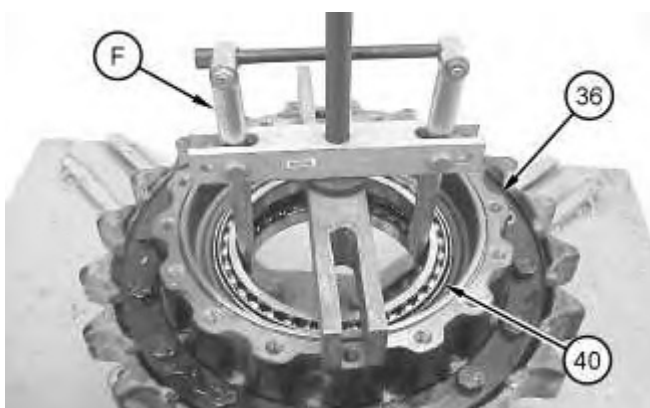

Illustration 28

g01147934

30. Remove Duo-Cone seal (39B) from housing (36).
31. Use Tooling (F) in order to remove bearings (40) and (41) from housing (36).
32. If necessary, remove the final drive sprocket from the sprocket housing. Refer to Disassembly and Assembly, "Final Drive Sprocket - Remove and Install".

[Previous Screen](#)

Product: EXCAVATOR

Model: 324D L EXCAVATOR SYM

Configuration: 324D L & LN Excavator SYM00001-UP (MACHINE) POWERED BY C-7 Engine

Disassembly and Assembly**324D, 325D, 326D and 329D Excavators and 329D MHPU Mobile Hydraulic Power Unit Machine Systems**

Media Number -REN8646-22

Publication Date -01/02/2015

Date Updated -12/09/2018

i03508206

Final Drive - Disassemble

SMCS - 4050-015

S/N - A3R1022-UP

S/N - BFC1-UP

S/N - BYS1-UP

S/N - CYW1-UP

S/N - CZF1-UP

S/N - DBH380-UP

S/N - DJF1-UP

S/N - DTZ1-UP

S/N - EBM1-UP

S/N - EJC644-UP

S/N - GPB802-UP

S/N - J8D1-UP

S/N - J9D1-UP

S/N - JAT1-UP

S/N - JHJ1-UP

S/N - JJG814-UP

S/N - JZR1-UP

S/N - KBE241-UP

S/N - L5G1-UP

S/N - LAB416-UP

S/N - LAL251-UP

S/N - MCL202-UP

S/N - MNB1-UP

S/N - MND1-UP

S/N - NAC251-UP

S/N - PKE815-UP

S/N - PYT1-UP

S/N - RSK1-UP

S/N - SCR775-UP

S/N - SCY1-UP

S/N - SYM618-UP

S/N - T2D323-UP

S/N - TPM1-UP

S/N - TRH1-UP

S/N - TSN1-UP

S/N - WDK1-UP

S/N - WLT1-UP

S/N - XDB1-UP

S/N - YFW1-UP

Disassembly Procedure

Table 1

Required Tools

Tool	Part Number	Part Description	Qty
A	1P-2420	Transmission Repair Stand	1
B	138-7573	Link Bracket	2
C	1P-1863	Retaining Ring Pliers	1
D	138-7575	Link Bracket	3
E	4C-8359	Eyebolt	2
F	138-7574	Link Bracket	2
G	138-7576	Link Bracket	2

Start By:

- a. Start by removing the final drive. Refer to Disassembly and Assembly, "Final Drive - Remove".

Note: Cleanliness is an important factor. Before the disassembly procedure, the exterior of the component should be thoroughly cleaned. This will prevent dirt from entering the internal mechanism.

1. Put an alignment mark across the sections of the final drive for assembly purposes. The parts must be reinstalled to the original locations.



Illustration 1

g00892878

2. Use Tooling (G) and a suitable lifting device to position the final drive assembly onto Tooling (A). The weight of the final drive assembly is approximately 550 kg (1200 lb).
3. Remove bolts (1).

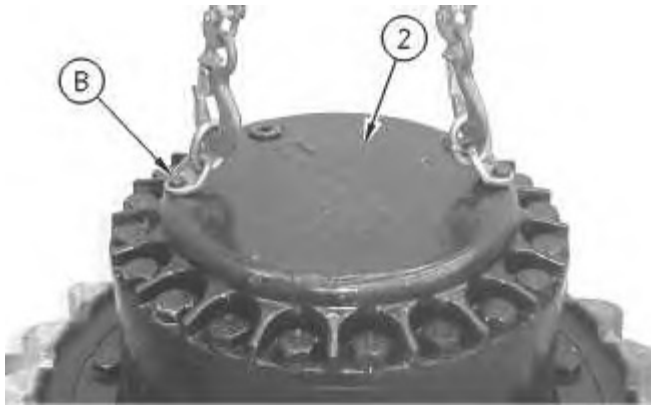

Illustration 2

g00892883

4. Use Tooling (B) and a suitable lifting device to remove cover (2). The weight of cover (2) is approximately 32 kg (70 lb).

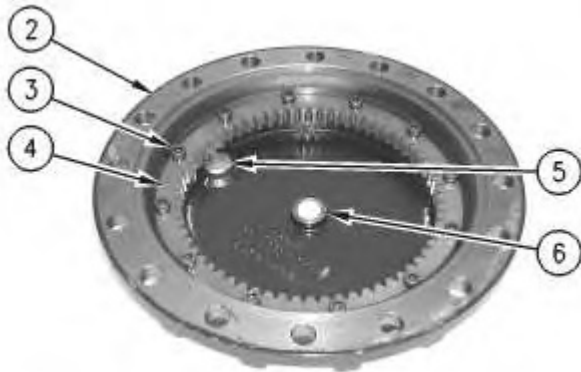

Illustration 3

g00892888

5. Remove bolts (3) and gear (4). Check plate (6). Replace plate (6) if plate (6) is worn. Remove plugs (5) from cover (2).



Illustration 4

g00892906

6. Remove O-ring seals (7) from plugs (5).



Illustration 5

g00892930

7. Remove gear (8) and spacer (9).



Illustration 6

g00892965

8. Use Tooling (C) to remove retaining ring (10). Remove washer (11) and gear (12). Remove bearing assembly (13) and washer (14).
9. Repeat Step 8 for the other two gear assemblies.

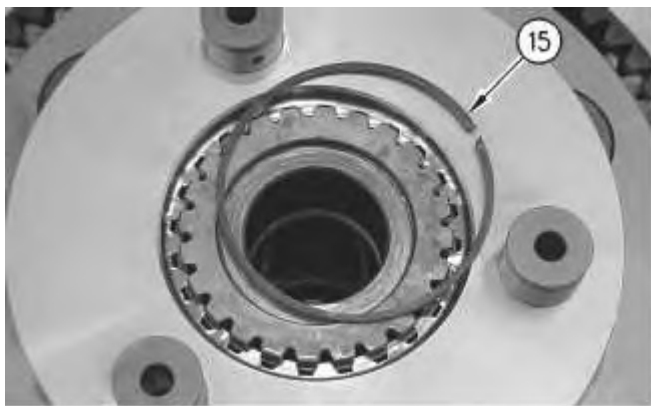

Illustration 7

g00892968

10. Remove retaining ring (15).

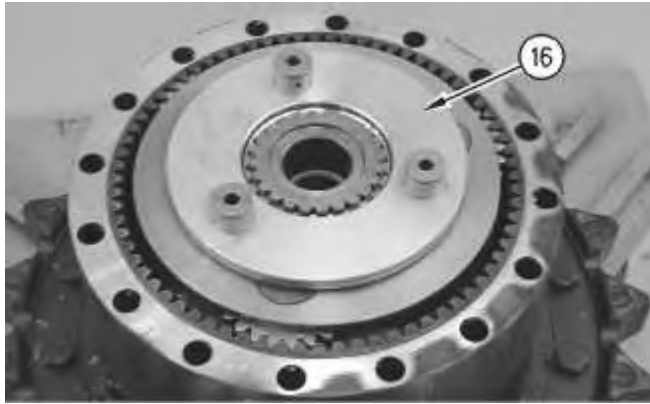

Illustration 8

g00892975

11. Remove carrier assembly (16).

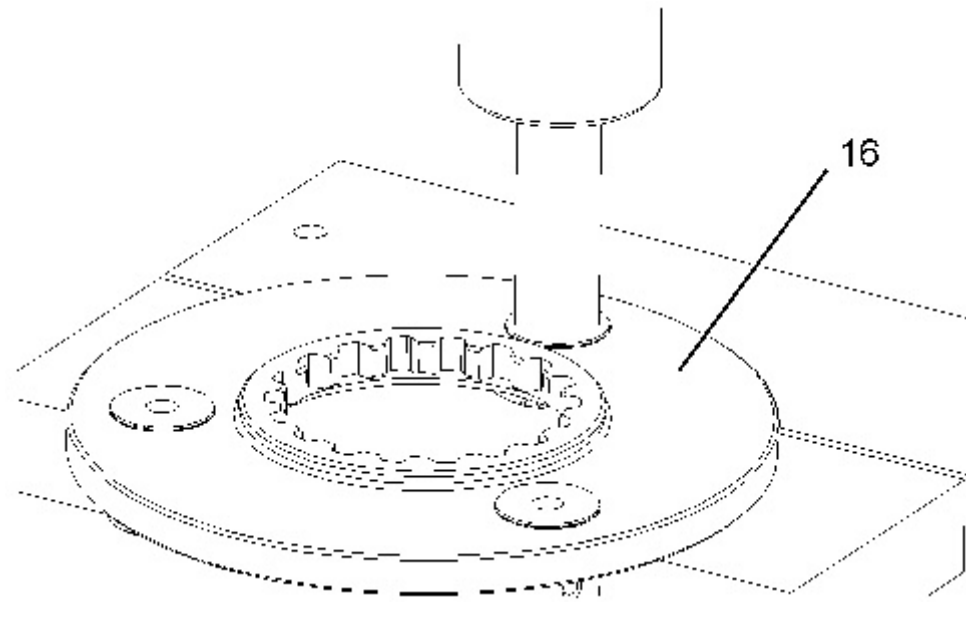

Illustration 9

g01389804

12. Use a suitable press to remove the shafts from carrier assembly (16).

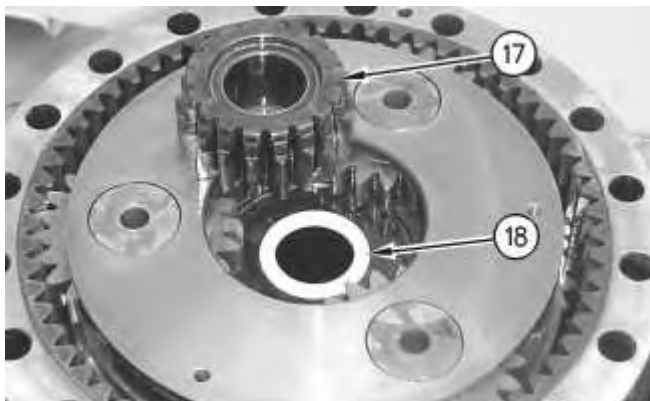

Illustration 10

g00892977

13. Remove gear (17) and spacer (18).

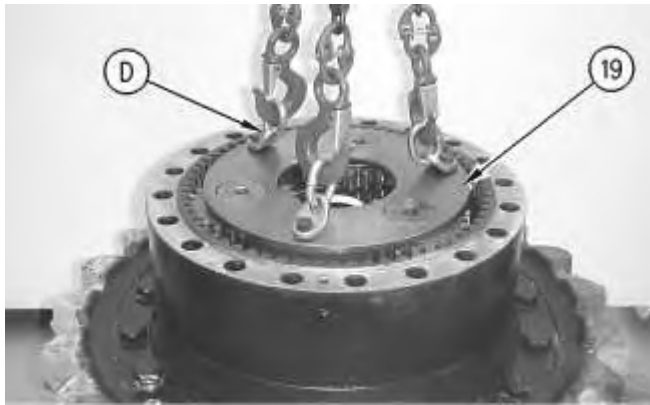

Illustration 11

g00892997

14. Use Tooling (D) and a suitable lifting device to remove planetary carrier (19). The weight of planetary carrier (19) is approximately 48 kg (105 lb).

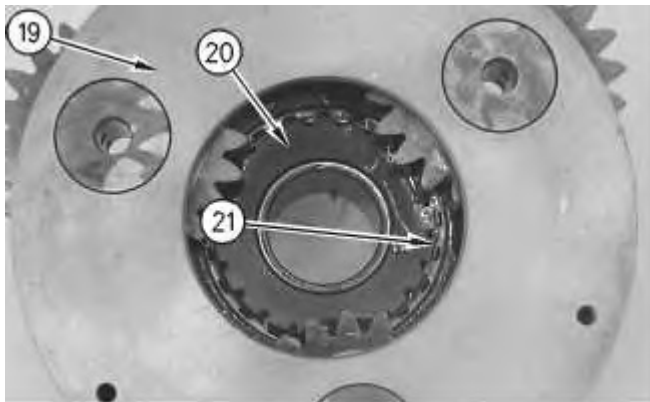

Illustration 12

g00893019

15. Remove retaining ring (21). Lift planetary carrier (19) off sun gear (20).



Illustration 13

g00896860

16. Drive spring pin (23) into planetary shaft (22).



Illustration 14

g00893043

17. Remove planetary shaft (22). Use a suitable punch to remove spring pin (23) from planetary shaft (22).

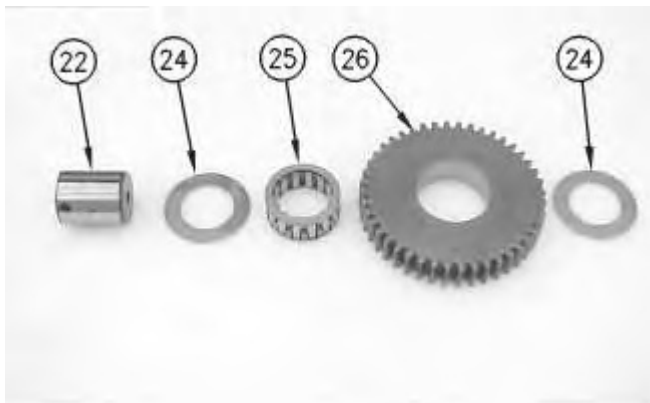

Illustration 15

g00896863

18. Remove washers (24) and bearing (25) from planetary gear (26).
19. Repeat Steps 16 through 18 for the other two planetary gears.

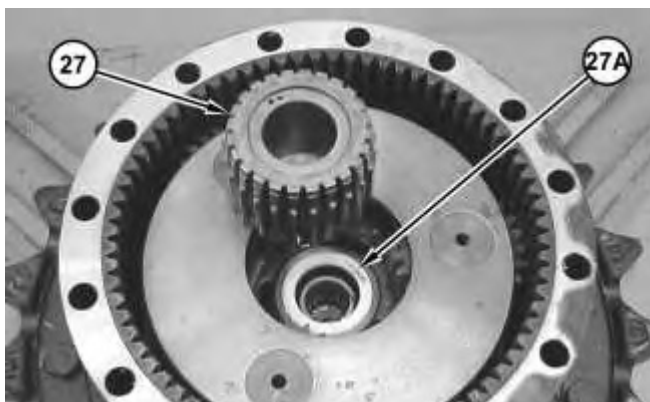

Illustration 16

g01842853

20. Remove gear (27). Remove spacer (27A).

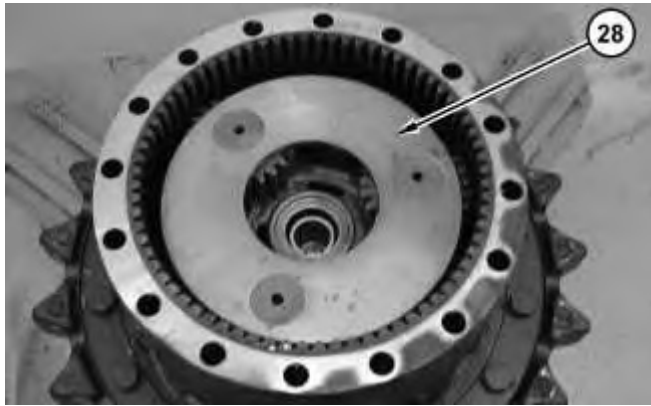

Illustration 17

g01842974

21. Use two people to remove carrier assembly (28). The weight of carrier assembly (28) is approximately 38 kg (85 lb).



Illustration 18

g01843140

22. Drive spring pin (30) into shaft (29).



Illustration 19

g00893658

23. Remove shaft (29). Use a suitable punch to remove spring pin (30) from shaft (29).
-

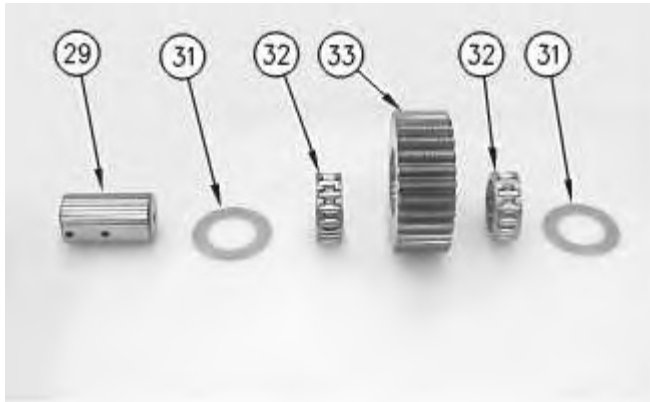

Illustration 20

g00893674

24. Remove washers (31) and bearings (32) from planetary gear (33).
25. Repeat Steps 22 through 24 for the other three planetary gears.



Illustration 21

g01208300

26. Fasten Tooling (E) and a suitable lifting device to ring gear (34), as shown. Remove ring gear (34) from sprocket housing (35). The weight of ring gear (34) is approximately 66 kg (146 lb).



Illustration 22

g01208542

27. Remove O-ring seal (36) from sprocket housing (35).

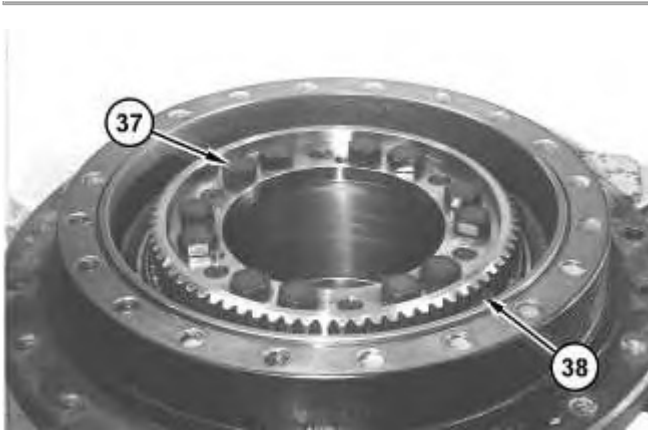

Illustration 23

g01208553

28. Remove bolts (37) from coupling gear (38).

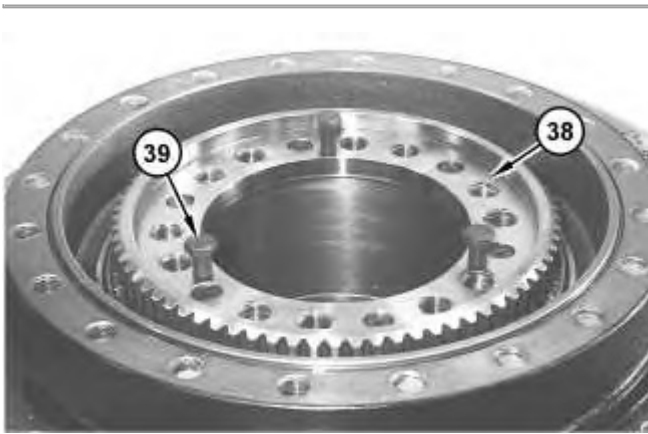

Illustration 24

g01208572

29. Install suitable forcing bolts (39) in coupling gear (38). Tighten the forcing bolts evenly in order to loosen coupling gear (38). Remove the coupling gear from the motor housing.



Illustration 25

g01208578



Illustration 26

g01208625

30. Remove shims (40) from the motor housing.

Note: Inner cones and outer bearing cones (42) are a slip fit on the motor housing. While you remove sprocket housing (35) from the motor housing, inner bearing cone (42) may stay with the sprocket housing or the inner bearing cone may stay on the motor housing.

31. Fasten Tooling (F) and a suitable lifting device to sprocket housing (35). Separate the sprocket housing from the motor housing. The weight of sprocket housing (35) is approximately 109 kg (240 lb).



Illustration 27

g01208626

32. Remove the locating pins from the motor housing.
 33. Remove Duo-Cone seal (41) from the motor housing.
 34. If inner bearing cone (42) remained on the motor housing, then remove the inner bearing cone.
-



Suggest:

If the above button click is invalid.

Please download this document

first, and then click the above link

to download the complete manual.

Thank you so much for reading



Illustration 28

g01208633

35. Remove Duo-Cone seal (43) from the sprocket housing.
36. If inner bearing cone (42) remained on the sprocket housing, then remove the inner bearing cone.
37. Remove the bearing cups from the sprocket housing.

<https://www.ebooklibonline.com>

Hello dear friend!

Thank you very much for reading.

Enter the link into your browser.

The full manual is available for immediate download.

<https://www.ebooklibonline.com>