



# Service Repair Manual

## **Models**

320D2 GC Excavator

---

[Previous Screen](#)

Product: EXCAVATOR

Model: 320D2 GC EXCAVATOR ZBH

Configuration: 320D2 GC Excavator ZBH00001-UP (MACHINE) POWERED BY C4.4 Engine

## Disassembly and Assembly

### C4.4 Engines for Caterpillar Built Machines

Media Number -UENR4525-09

Publication Date -01/06/2015

Date Updated -22/05/2018

i05740846

## Idler Gear - Remove

SMCS - 1206-011

### Removal Procedure (Standard Idler Gear)

Table 1

Required Tools			
Tool	Part Number	Part Description	Qty
A	230-6284	Timing Pin (Camshaft)	1
B	230-6283	Timing Pin (Crankshaft)	1

#### Start By:

- a. If the engine is equipped with an air compressor, remove the air compressor. Refer to Disassembly and Assembly, "Air Compressor - Remove and Install".
- b. If the engine is equipped with a vacuum pump, remove the vacuum pump. Refer to Disassembly and Assembly, "Vacuum Pump - Remove and Install".
- c. If the engine is equipped with an accessory drive, remove the accessory drive. Refer to Disassembly and Assembly, "Accessory Drive - Remove and Install".
- d. Remove the fuel injection pump gear. Refer to Disassembly and Assembly, "Fuel Pump Gear - Remove".
- e. Remove the valve mechanism cover. Refer to Disassembly and Assembly, "Valve Mechanism Cover - Remove and Install".

**Note:** Care must be taken in order to ensure that the fuel injection pump timing is not lost during the removal of the fuel pump gear. Carefully follow the procedure in order to remove the fuel pump gear.

## NOTICE

**Keep all parts clean from contaminants.**

**Contaminants may cause rapid wear and shortened component life.**

---

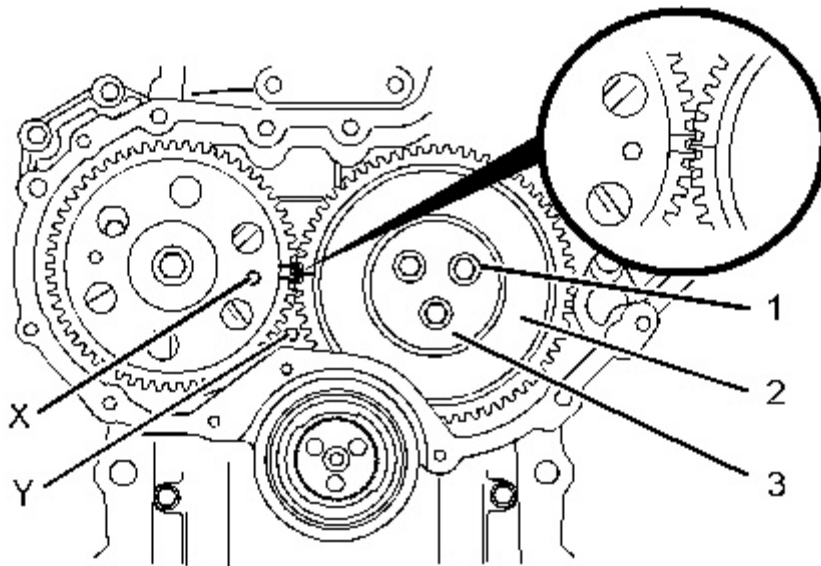

Illustration 1

g01343975

Alignment of timing marks

1. Ensure that Tooling (A) is installed into hole (X) in the camshaft gear. Use Tooling (A) in order to lock the camshaft in the correct position.

**Note:** Ensure that the gears are marked in order to show alignment. Refer to Illustration 1.

2. Ensure that Tooling (B) is installed in hole (Y) in the front housing. Use Tooling (B) in order to lock the crankshaft in the correct position.
-

**<https://www.ebooklibonline.com>**

Hello dear friend!

Thank you very much for reading.

Enter the link into your browser.

The full manual is available for immediate download.

**<https://www.ebooklibonline.com>**

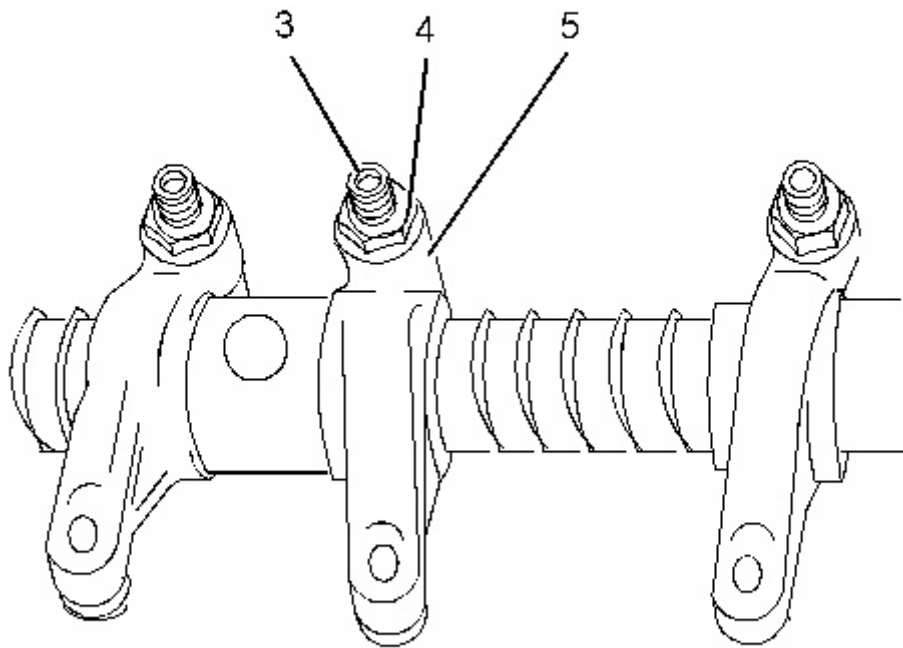

---

Illustration 2

g01348926

Typical example

3. Loosen nuts (4) on all rocker arms (5). Unscrew adjusters (3) on all rocker arms (5) until all valves are fully closed.

**Note:** Failure to ensure that ALL adjusters are fully unscrewed can result in contact between the valves and pistons.

4. Mark plate (3) in order to show orientation. Refer to Illustration 1.

**Note:** Identification will ensure that the plate can be installed in the original orientation.

5. Remove bolts (1). Refer to Illustration 1.

6. Remove plate (3).
-

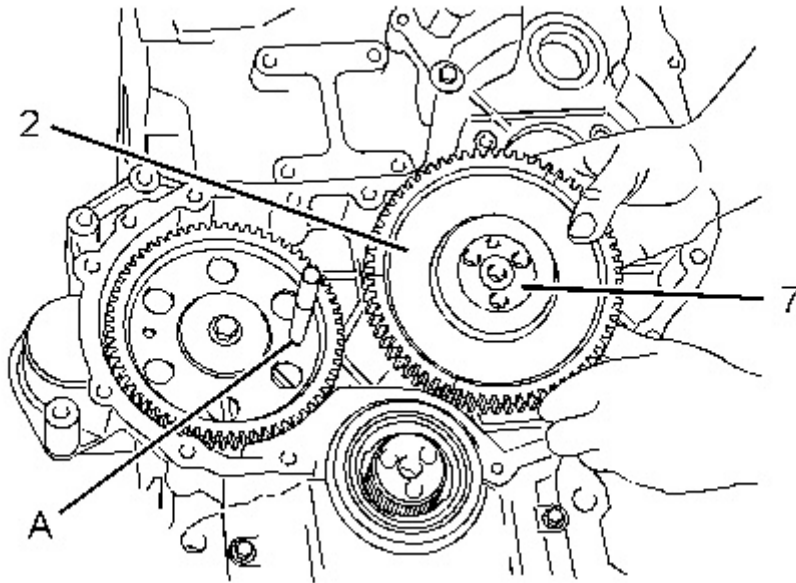

Illustration 3

g01269930

Typical example

7. Remove the assembly of idler gear (2) and hub (7) from the recess in the front housing.

**Note:** The idler gear must be tilted during removal.

8. Remove hub (7) from idler gear (2).

## Removal Procedure (Heavy-Duty Idler Gear)

Table 2

Required Tools			
Tool	Part Number	Part Description	Qty
A	230-6284	Timing Pin (Camshaft)	1
B	230-6283	Timing Pin (Crankshaft)	1
C	-	Bolt (M8x80mm)	1

### Start By:

- a. If the engine is equipped with an air compressor, remove the air compressor. Refer to Disassembly and Assembly, "Air Compressor - Remove and Install".
- b. If the engine is equipped with a vacuum pump, remove the vacuum pump. Refer to Disassembly and Assembly, "Vacuum Pump - Remove and Install".
- c. If the engine is equipped with an accessory drive, remove the accessory drive. Refer to Disassembly and Assembly, "Accessory Drive - Remove and Install".

- d. Remove the fuel injection pump gear. Refer to Disassembly and Assembly, "Fuel Pump Gear - Remove".
- e. Remove the valve mechanism cover. Refer to Disassembly and Assembly, "Valve Mechanism Cover - Remove and Install".

**Note:** Care must be taken in order to ensure that the fuel injection pump timing is not lost during the removal of the fuel pump gear. Carefully follow the procedure in order to remove the fuel pump gear.

---

## NOTICE

**Keep all parts clean from contaminants.**

**Contaminants may cause rapid wear and shortened component life.**

---

**Note:** The assembly of heavy-duty idler gear is not serviceable. Do not disassemble the heavy-duty idler gear.

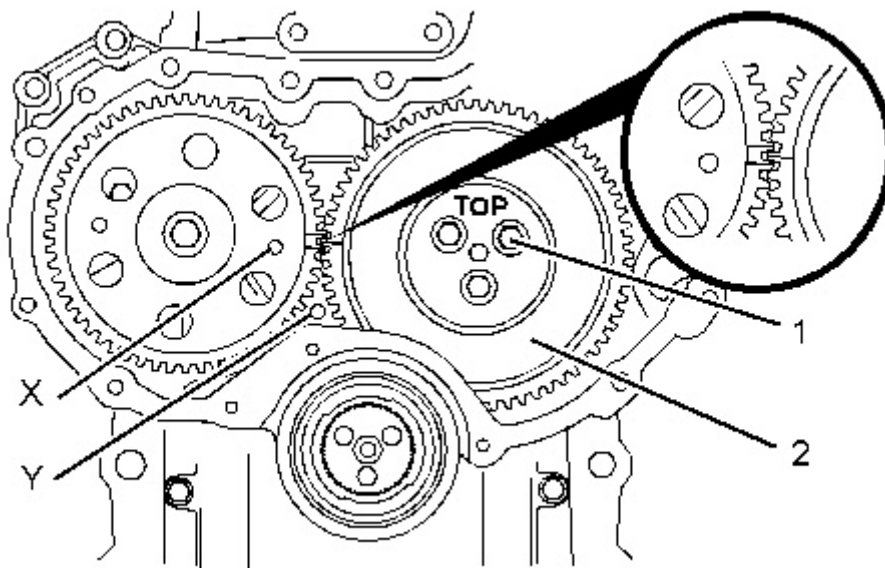

Illustration 4

g01343977

Alignment of timing marks

1. Ensure that Tooling (A) is installed into hole (X) in the camshaft gear. Use Tooling (A) in order to lock the camshaft in the correct position.

**Note:** Ensure that the gears are marked in order to show alignment. Refer to Illustration 4.

2. Ensure that Tooling (B) is installed in hole (Y) in the front housing. Use Tooling (B) in order to lock the crankshaft in the correct position.
-

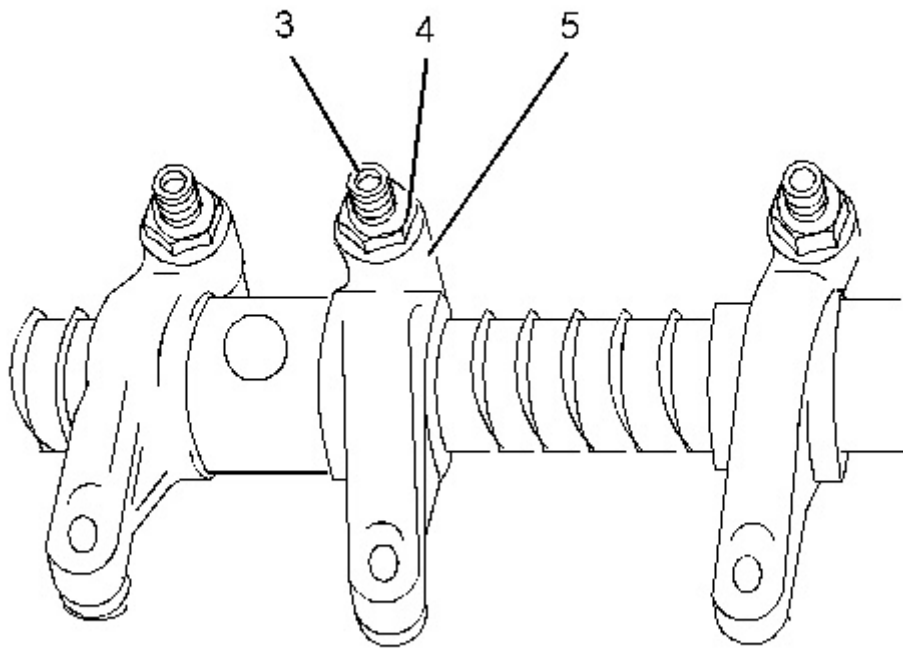

---

Illustration 5  
Typical example

g01348930

3. Loosen nuts (4) on all rocker arms (5). Unscrew adjusters (3) on all rocker arms (5) until all valves are fully closed.

**Note:** Failure to ensure that ALL adjusters are fully unscrewed can result in contact between the valves and pistons.

4. Remove bolts (1) from the assembly of heavy-duty idler gear (2). Refer to Illustration 4.
-

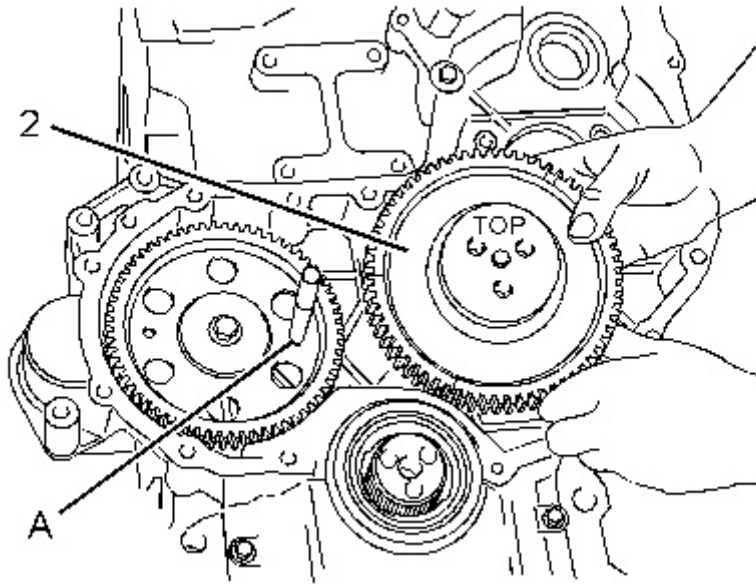

Illustration 6  
Typical example

g01269933

5. Remove the assembly of idler gear (2) from the recess in the front housing.

**Note:** The idler gear must be tilted during removal.

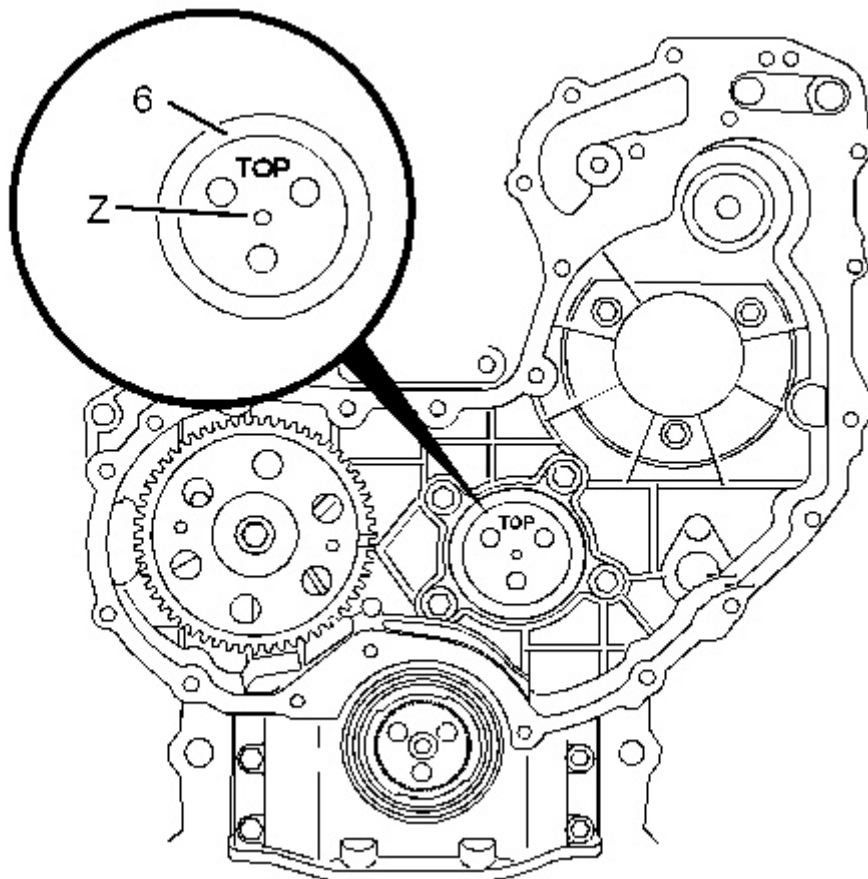

Illustration 7  
Typical example

g01348835

6. If necessary, remove plate (6). Install Tooling (C) into threaded hole (Z) in order to remove plate (6).

---

[Copyright 1993 - 2020 Caterpillar Inc.](#)

Fri Jun 5 10:43:09 UTC+0800 2020

[All Rights Reserved.](#)

[Private Network For SIS Licensees.](#)

Previous Screen

Product: EXCAVATOR

Model: 320D2 GC EXCAVATOR ZBH

Configuration: 320D2 GC Excavator ZBH00001-UP (MACHINE) POWERED BY C4.4 Engine

**Disassembly and Assembly**  
**C4.4 Engines for Caterpillar Built Machines**

Media Number -UENR4525-09

Publication Date -01/06/2015

Date Updated -22/05/2018

i05740850

## Idler Gear - Install

SMCS - 1206-012

### Installation Procedure (Standard Idler Gear)

Table 1

Required Tools			
Tool	Part Number	Part Description	Qty
A	230-6284	Timing Pin (Camshaft)	1
B	230-6283	Timing Pin (Crankshaft)	1
C	9U-7324	Indicator Bracket	1
	7H-1942	Dial Indicator	1
	3S-3268	Indicator Contact Point	1
	7H-1940	Universal Attachment	1

---

#### NOTICE

**Keep all parts clean from contaminants.**

**Contaminants may cause rapid wear and shortened component life.**

---

1. Ensure that number one piston is at the top center position on the compression stroke. Refer to the Systems Operation, Testing and Adjusting, "Finding Top Center Position for No. 1 Piston".
-

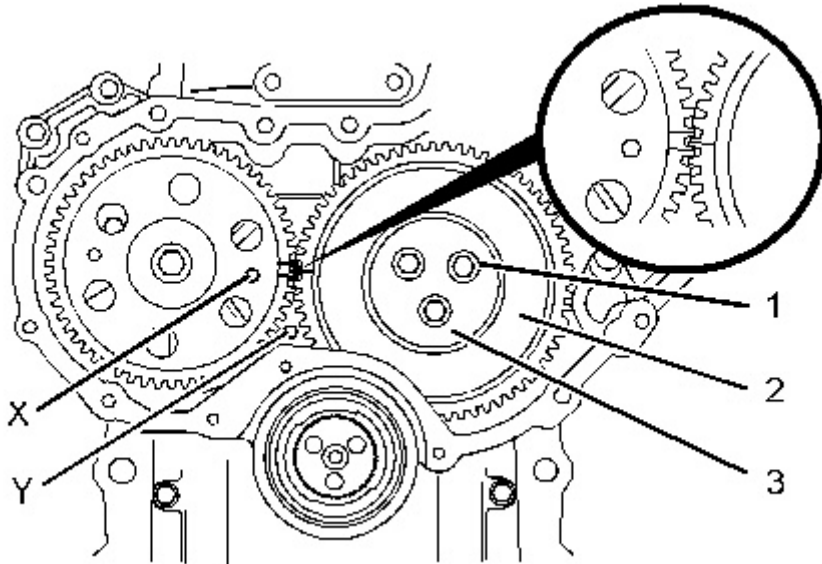

Illustration 1

g01343975

Alignment of timing marks

2. Ensure that Tooling (A) is installed into hole (X) in camshaft gear (1).
3. Ensure that Tooling (B) is installed in hole (Y) in the front housing. Use Tooling (B) in order to lock the crankshaft in the correct position. Refer to Systems Operation, Testing and Adjusting, "Finding Top Center Position for No.1 Piston".

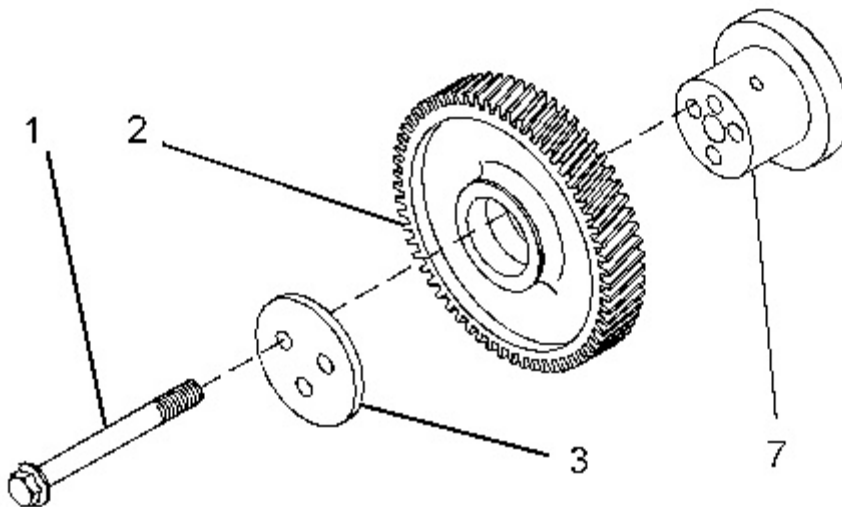
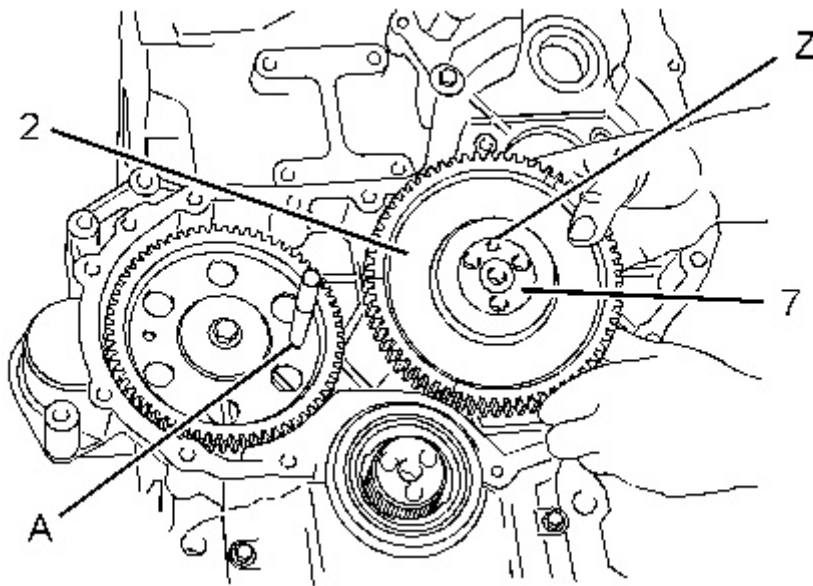

Illustration 2

g01269934

4. Clean idler gear (2) and inspect the idler gear for wear or damage. Refer to Specifications, "Gear Group (Front)" for more information. If necessary, replace the idler gear.
5. Clean hub (7) and inspect the hub for wear or damage. Refer to Specifications, "Gear Group (Front)" for more information. If necessary, replace the hub.

- Lubricate hub (7) with clean engine oil. Slide the hub into idler gear (2). Ensure that the timing marks are toward the front of the idler gear.
- 



---

Illustration 3

g01269935

Typical example

- Align the timing mark on idler gear (2) with the timing mark on the camshaft gear. Refer to the Illustration 1. Install the assembly of idler gear (2) and hub (7) into the recess in the timing case. Ensure that oil hole (Z) is to the top of the hub.
- Note:** The idler gear must be tilted during installation. Ensure that the holes in the hub are aligned with the holes in the cylinder block.
- Clean plate (3) and inspect the plate for wear or damage. If necessary, replace the plate.
  - Lubricate plate (3) with clean engine oil. A used plate should be installed in the original orientation. If a new plate is installed, ensure that the holes in plate (3) are aligned with the holes in hub (7). Install plate (3) to hub (7).
  - Install bolts (1). Tighten bolts (1) to a torque of 44 N·m (32 lb ft).
-

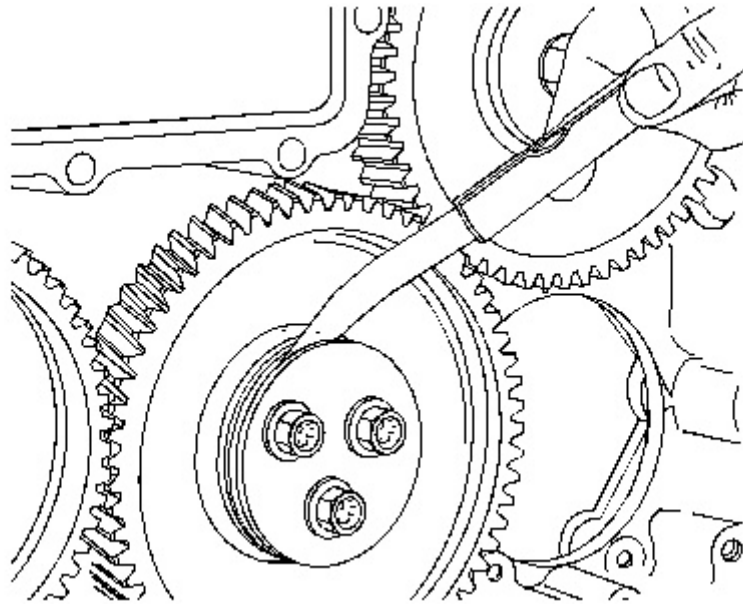

Illustration 4

g01269936

Checking end play by using a set of feeler gauges

11. Use a set of feeler gauges in order to check the end play for the idler gear. Refer to Specifications, "Gear Group (Front)" for more information.
12. Use Tooling (C) in order to check the backlash between the idler gear and the camshaft gear. Refer to Specifications, "Gear Group (Front)" for more information.
13. Use Tooling (C) in order to check the backlash between the idler gear and the crankshaft gear. Refer to Specifications, "Gear Group (Front)" for more information.
14. Lightly lubricate all of the gears with clean engine oil.

**End By:**

- a. Install the fuel injection pump gear. Refer to Disassembly and Assembly, "Fuel Pump Gear - Install".
- b. If the engine is equipped with an air compressor, install the air compressor. Refer to Disassembly and Assembly, "Air Compressor - Remove and Install".
- c. If the engine is equipped with a vacuum pump, install the vacuum pump. Refer to Disassembly and Assembly, "Vacuum Pump - Remove and Install".
- d. If the engine is equipped with an accessory drive, install the accessory drive. Refer to Disassembly and Assembly, "Accessory Drive - Remove and Install".

## Installation Procedure (Heavy-Duty Idler Gear)

Table 2

Required Tools			
Tool	Part Number	Part Description	Qty

A	230-6284	Timing Pin (Camshaft)	1
B	230-6283	Timing Pin (Crankshaft)	1
C	9U-7324	Indicator Bracket	1
	7H-1942	Dial Indicator	1
	3S-3268	Indicator Contact Point	1
	7H-1940	Universal Attachment	1

---

## NOTICE

**Keep all parts clean from contaminants.**

**Contaminants may cause rapid wear and shortened component life.**

---

1. Ensure that number one piston is at the top center position on the compression stroke. Refer to Systems Operation, Testing and Adjusting, "Finding Top Center Position for No. 1 Piston".

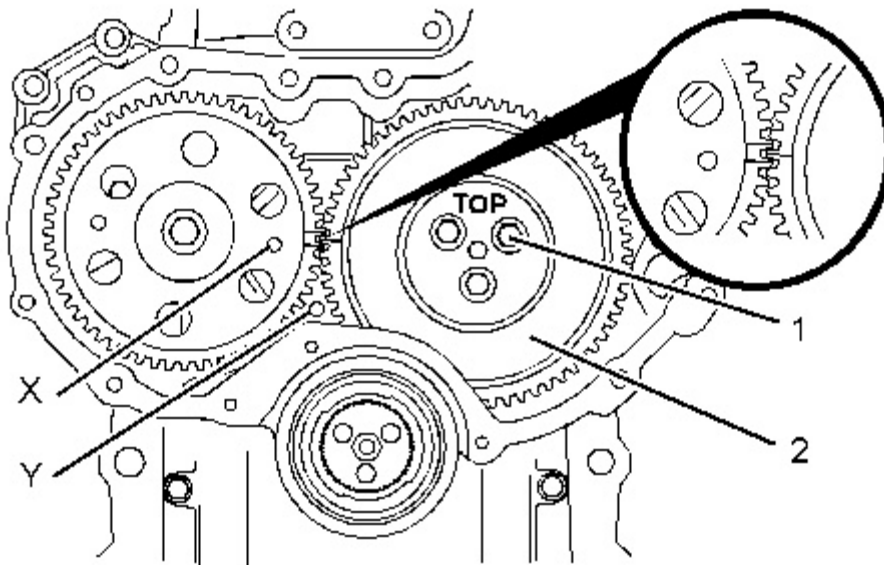
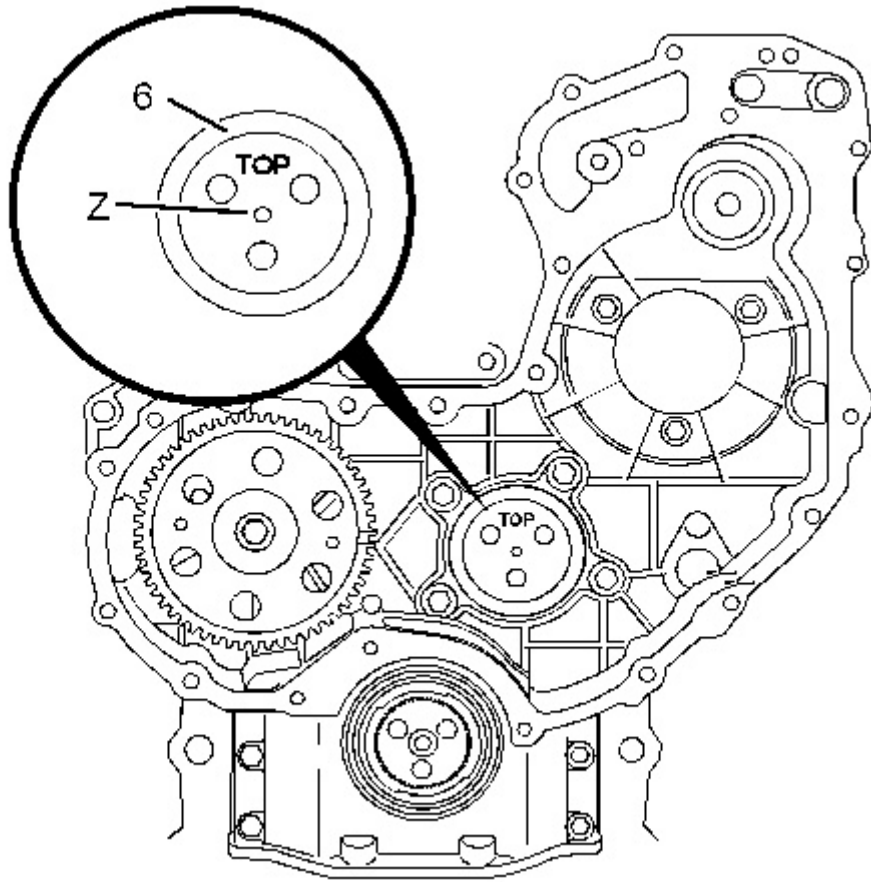

Illustration 5

g01343977

Alignment of timing marks

2. Ensure that Tooling (A) is installed into hole (X) in the camshaft gear.
  3. Ensure that Tooling (B) is installed in hole (Y) in the cylinder block. Use Tooling (B) in order to lock the crankshaft in the correct position. Refer to Systems Operation, Testing and Adjusting, "Finding Top Center Position for No.1 Piston".
-



---

Illustration 6  
Typical example

g01348946

4. Install plate (6) into the recess in the front housing.

**Note:** Ensure that the identification mark TOP is upward.

5. Clean the assembly of idler gear (2) and inspect the assembly of the idler gear for wear or damage. Refer to Specifications, "Gear Group (Front)" for more information. If necessary, replace the assembly of the idler gear.
  6. Lubricate the bearings in the assembly of idler gear (2) with clean engine oil.
-

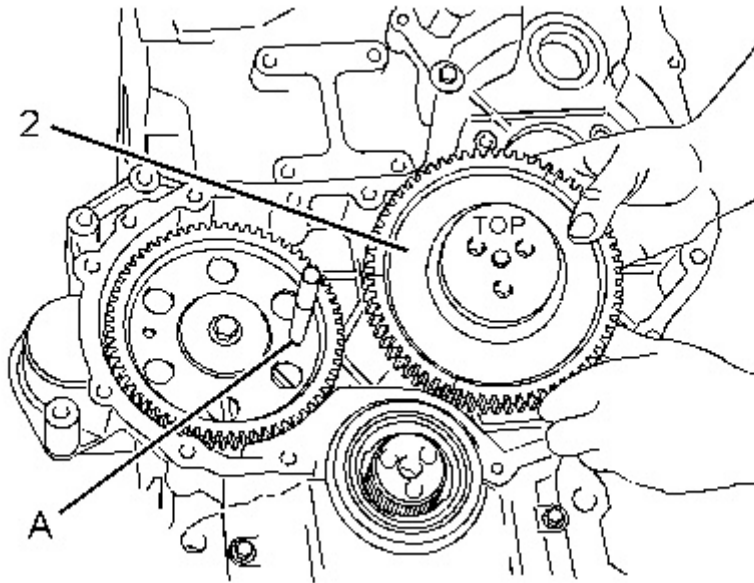

Illustration 7

g01269933

7. Align the timing mark on idler gear (2) with the timing mark on the camshaft gear. Refer to Illustration 5. Install the assembly of idler gear (2) into the recess in the timing case. Ensure that the identification mark TOP is upward.

**Note:** The idler gear must be tilted during installation. Ensure that the holes in the assembly of the idler gear are aligned with the holes in the cylinder block.

8. Install bolts (1). Tighten bolts (1) to a torque of 44 N·m (32 lb ft).

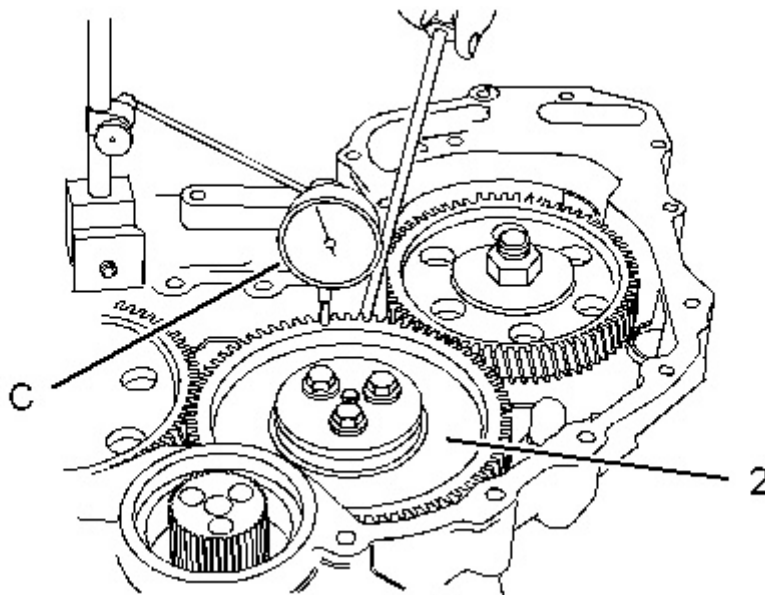

Illustration 8

g01269937

Checking end play by using a dial indicator group

9. Use Tooling (C) in order to check the end play of the idler gear. Refer to Specifications, "Gear Group (Front)" for more information.

10. Use Tooling (C) in order to check the backlash between the idler gear and the camshaft gear. Refer to Specifications, "Gear Group (Front)" for more information.
11. Use Tooling (C) in order to check the backlash between the idler gear and the crankshaft gear. Refer to Specifications, "Gear Group (Front)" for more information.
12. Lightly lubricate all of the gears with clean engine oil.

**End By:**

- a. Install the fuel injection pump gear. Refer to Disassembly and Assembly, "Fuel Pump Gear - Install".
- b. If the engine is equipped with an air compressor, install the air compressor. Refer to Disassembly and Assembly, "Air Compressor - Remove and Install".
- c. If the engine is equipped with a vacuum pump, install the vacuum pump. Refer to Disassembly and Assembly, "Vacuum Pump - Remove and Install".
- d. If the engine is equipped with an accessory drive, install the accessory drive. Refer to Disassembly and Assembly, "Accessory Drive - Remove and Install".

[Previous Screen](#)

Product: EXCAVATOR

Model: 320D2 GC EXCAVATOR ZBH

Configuration: 320D2 GC Excavator ZBH00001-UP (MACHINE) POWERED BY C4.4 Engine

## Disassembly and Assembly

### C4.4 Engines for Caterpillar Built Machines

Media Number -UENR4525-09

Publication Date -01/06/2015

Date Updated -22/05/2018

i05740852

## Housing (Front) - Remove

SMCS - 1151-011

### Removal Procedure

#### Start By:

- a. Remove the fan. Refer to Disassembly and Assembly, "Fan - Remove and Install".
- b. Remove the alternator. Refer to Disassembly and Assembly, "Alternator - Remove".
- c. Remove the crankshaft pulley. Refer to Disassembly and Assembly, "Crankshaft Pulley - Remove and Install".
- d. Remove the engine oil pan. Refer to Disassembly and Assembly, "Engine Oil Pan - Remove and Install".
- e. Remove the timing gears. Refer to Disassembly and Assembly, "Gear Group (Front) - Remove and Install".
- f. Remove the fuel injection pump. Refer to Disassembly and Assembly, "Fuel Injection Pump - Remove".

---

#### NOTICE

**Keep all parts clean from contaminants.**

**Contaminants may cause rapid wear and shortened component life.**

---

---

#### NOTICE

**Care must be taken to ensure that fluids are contained during performance of inspection, maintenance, testing, adjusting and repair of the product. Be prepared to collect the fluid with suitable containers before opening any compartment or disassembling any component containing fluids.**

**Dispose of all fluids according to local regulations and mandates.**

---

1. Ensure that the coolant is drained into a suitable container for storage or disposal. Refer to Operation and Maintenance Manual, "Cooling System Coolant - Change" for the correct procedure.
- 

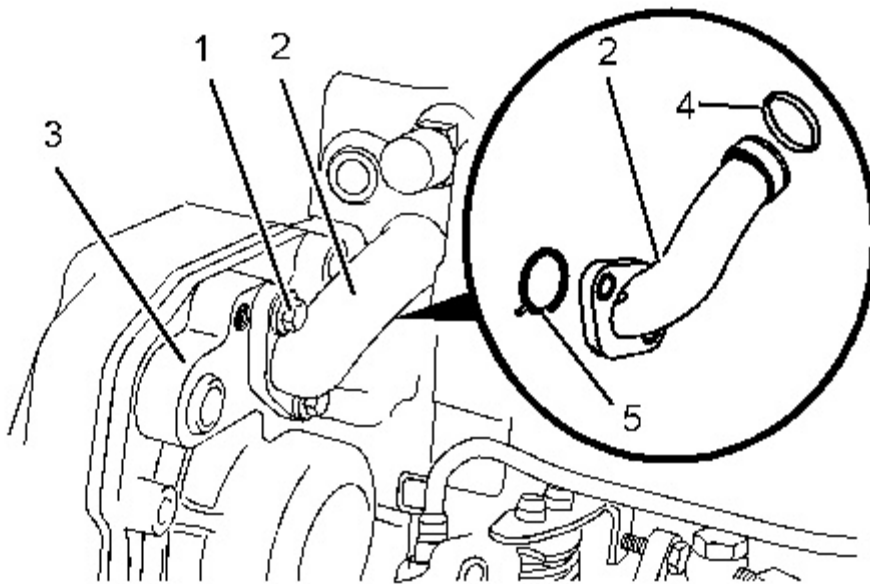

---

Illustration 1

g01337982

Typical example

2. Remove bolts (1) that secure bypass tube (2) to front housing (3). Note the position of any brackets that are secured by the bolts. Remove bypass tube (2). Remove O-ring seals (4) and (5) from bypass tube (2).
-

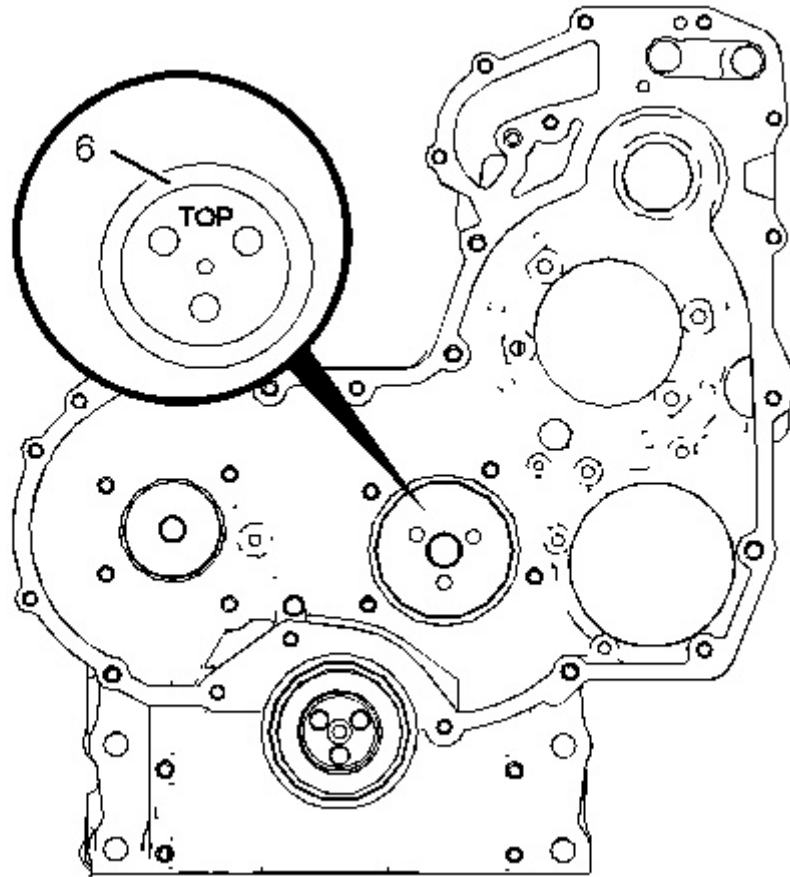

---

Illustration 2

g03663329

3. If the engine is equipped with a heavy duty idler gear. Remove plate (6). Refer to Disassembly and Assembly, "Idler Gear - Remove" for the correct procedure.
-

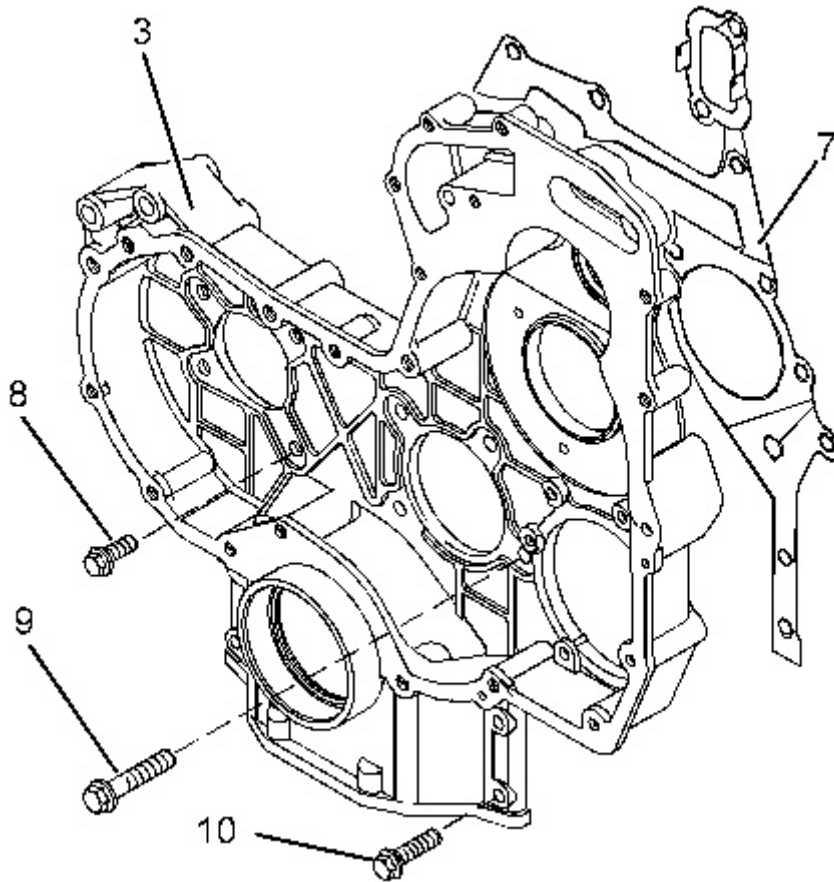

---

Illustration 3  
Typical example

g01350336

4. Remove bolts (8), (9) and (10) from front housing (3).

**Note:** The bolts are three different lengths. Note the positions of the different bolts.

5. Remove front housing (3) from the cylinder block.

6. Remove joint (7).
-

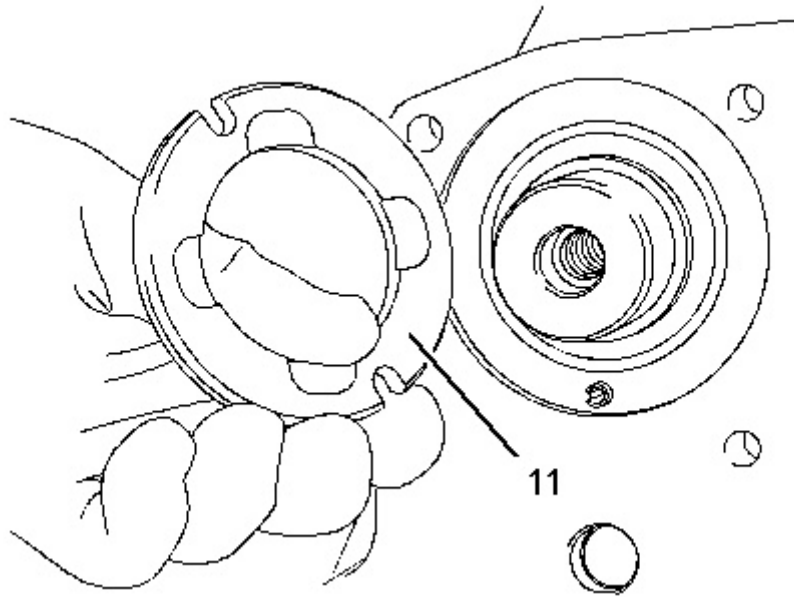

---

Illustration 4  
Typical example

g01350337

7. Remove thrust washer (11) from the cylinder block.

[Previous Screen](#)

Product: EXCAVATOR

Model: 320D2 GC EXCAVATOR ZBH

Configuration: 320D2 GC Excavator ZBH00001-UP (MACHINE) POWERED BY C4.4 Engine

## Disassembly and Assembly

### C4.4 Engines for Caterpillar Built Machines

Media Number -UENR4525-09

Publication Date -01/06/2015

Date Updated -22/05/2018

i05740857

## Housing (Front) - Install

SMCS - 1151-012

### Installation Procedure

Table 1

Required Tools			
Tool	Part Number	Part Description	Qty
A	6V-6640	Sealant	1
B	-	Guide Bolt (M8 by 80 mm)	2
C	319-6486	Alignment Tool	1
	-	Bolts (M10 by 50 mm)	3
D	-	Straight Edge	1
E	1U-6396	O-Ring Assembly Compound	1

---

### NOTICE

**Keep all parts clean from contaminants.**

**Contaminants may cause rapid wear and shortened component life.**

---

1. Ensure that the front housing is clean and free from damage. If necessary, replace the front housing.

If necessary, install blanking plugs to a new front housing. Use Tooling (A) to seal all D-plugs.

2. Check the condition of the crankshaft front seal. If the front seal is damaged, remove the front seal from the front housing.
3. Clean the mating surfaces of the cylinder block.

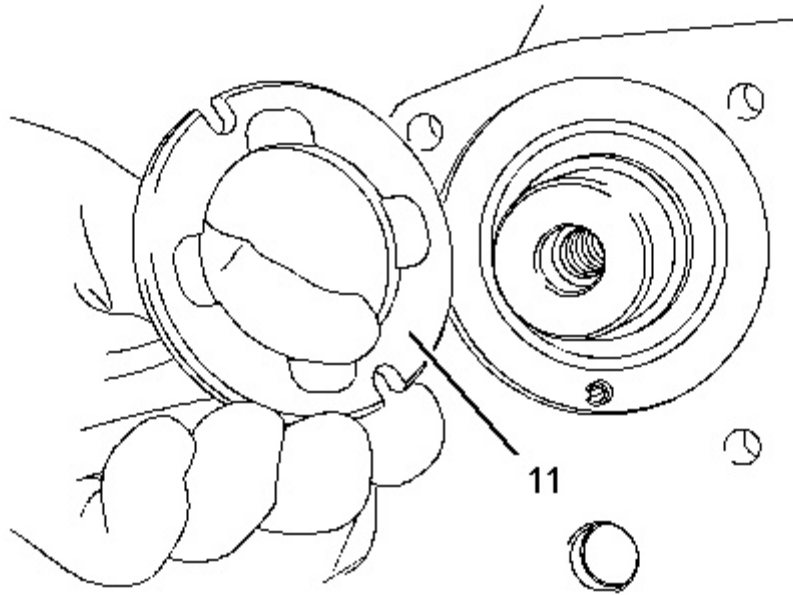

Illustration 1  
Typical example

g01350337

4. Install thrust washer (11) into the recess in the cylinder block. Refer to Disassembly and Assembly, "Camshaft - Install" for more information.
-



**Suggest:**

**If the above button click is invalid.**

**Please download this document**

**first, and then click the above link**

**to download the complete manual.**

**Thank you so much for reading**

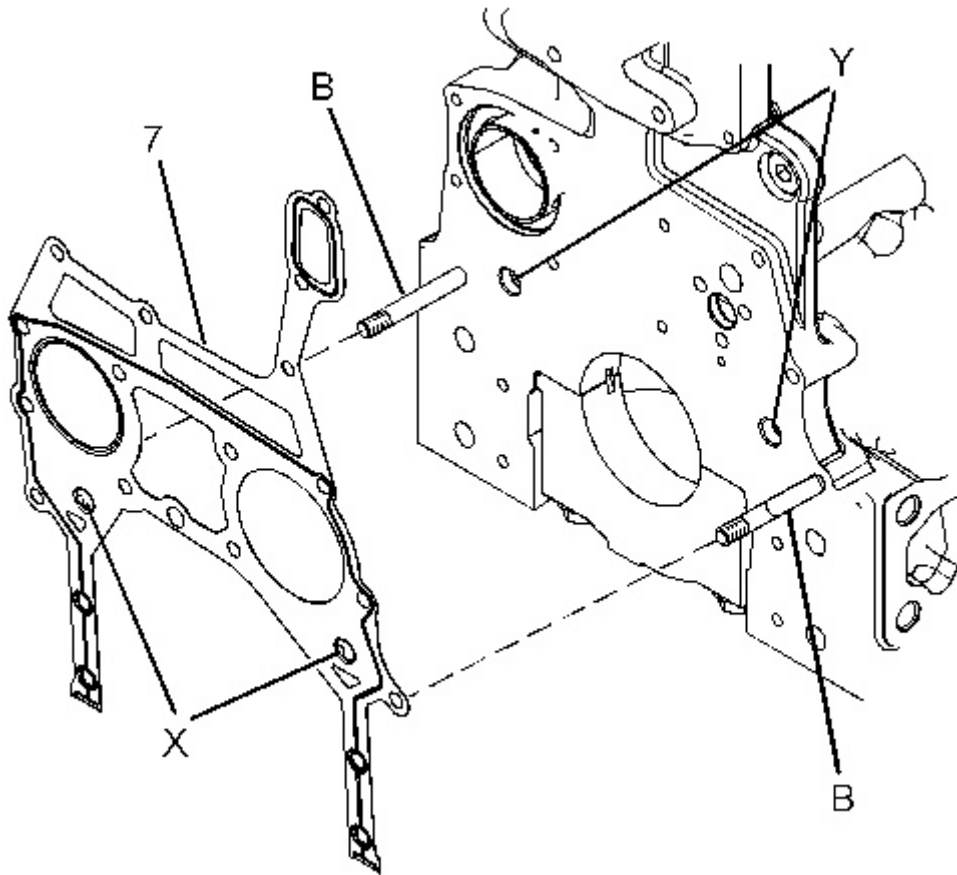

---

Illustration 2  
Typical example

g01350343

5. Install Tooling (B) to the cylinder block. Refer to Illustration 2.
6. Install Tooling (C) to the cylinder block.
7. Align a new joint (7) with Tooling (B). Install the joint to the cylinder block.

**Note:** Ensure that tabs (X) on the joint are engaged in holes (Y) in the cylinder block.

---

**<https://www.ebooklibonline.com>**

Hello dear friend!

Thank you very much for reading.

Enter the link into your browser.

The full manual is available for immediate download.

**<https://www.ebooklibonline.com>**