



# Service Repair Manual

## **Models**

318C Excavator

---

[Previous Screen](#)

Product: EXCAVATOR

Model: 318C EXCAVATOR BTG

Configuration: 318C Excavators BTG00001-UP (MACHINE) POWERED BY 3066 Engine

## Disassembly and Assembly 318C Excavator Machine Systems

Media Number -REN6647-04

Publication Date -01/03/2009

Date Updated -05/03/2009

i02275023

## Final Drive - Disassemble

SMCS - 4050-015

S/N - BTG1-UP

S/N - DAH1-UP

S/N - FAA1-UP

## Disassembly Procedure

Table 1

Required Tools			
Tool	Part Number	Part Description	Qty
A	1P-2420	Transmission Repair Stand	1
B	154-6360	Forcing Bolt	2
C	1P-2320	Combination Puller	1
D	138-7576	Link Bracket	2
	8B-7554	Bearing Cup Puller Gp	1
E	7S-7786	Puller Leg	2
	8B-7560	Step Plate	1
F	246-7504	Socket	1
G	6V-6080	Torque Multiplier Gp	1
	9U-5006	Torque Wrench	1
H	FT-2993	Reaction Bar	1

J	154-9316	Metric Thread File	1
K	1P-1864	Retaining Ring Pliers As	1
L	1U-8151	Drill Bit (5 mm)	1

**Start By:**

- A. Remove the final drive. Refer to Disassembly and Assembly, "Final Drive - Remove".

---

**NOTICE**

**Care must be taken to ensure that fluids are contained during performance of inspection, maintenance, testing, adjusting and repair of the product. Be prepared to collect the fluid with suitable containers before opening any compartment or disassembling any component containing fluids.**

**Refer to Special Publication, NENG2500, "Caterpillar Tools and Shop Products Guide" for tools and supplies suitable to collect and contain fluids on Caterpillar products.**

**Dispose of all fluids according to local regulations and mandates.**

---

1. Drain the final drive into a suitable container. Refer to Operation and Maintenance Manual, "Capacities (Refill)".

**Note:** Cleanliness is an important factor. Before the disassembly procedure, the exterior of the component should be thoroughly cleaned. This will prevent dirt from entering the internal mechanism.

2. Put an alignment mark across the sections of the final drive for assembly purposes. The parts must be reinstalled in the part's original locations.

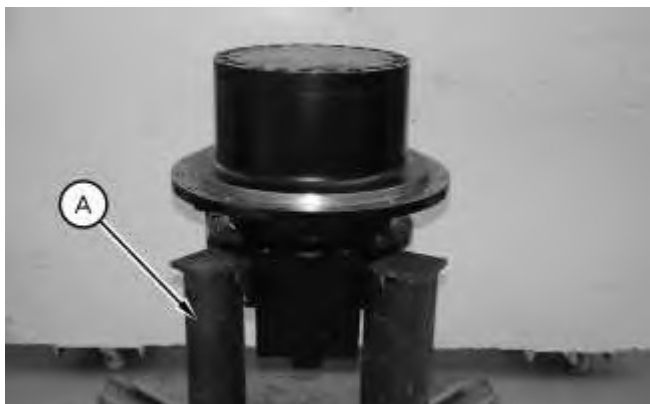

---

Illustration 1

g01139499

**<https://www.ebooklibonline.com>**

Hello dear friend!

Thank you very much for reading.

Enter the link into your browser.

The full manual is available for immediate download.

**<https://www.ebooklibonline.com>**

3. Fasten the final drive to Tooling (A), as shown. If necessary, remove the final drive sprocket. Refer to Disassembly and Assembly, "Final Drive Sprocket - Remove and Install". The weight of the final drive is approximately 250 kg (550 lb).

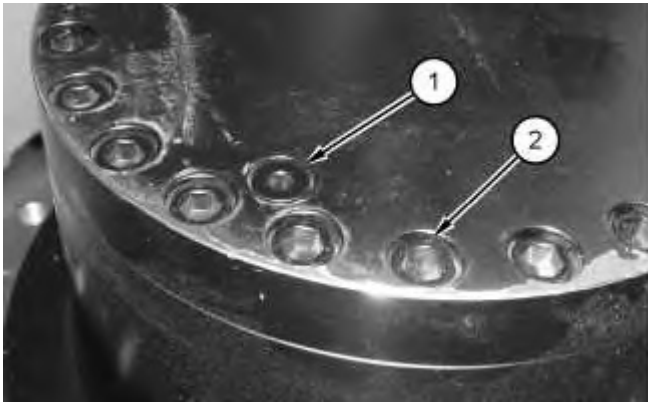

Illustration 2

g01139500

4. Remove drain plugs (1) .
5. Remove bolts (2) .

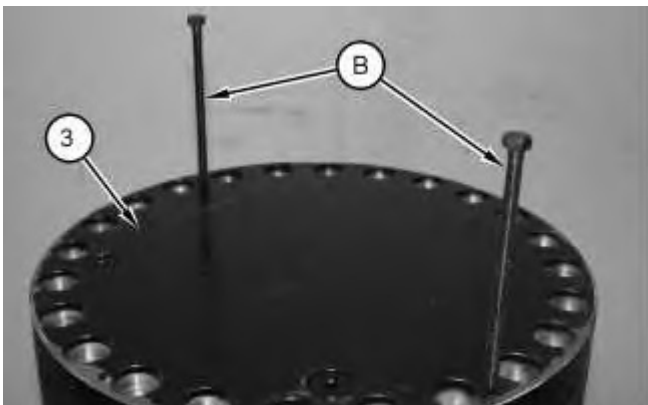

Illustration 3

g01139501

6. Use Tooling (B) to separate cover (3) from the final drive. Remove cover (3) .
-



Illustration 4

g01139502

7. Remove planetary assembly (4) .
8. Remove O-ring seal (5) .



Illustration 5

g01139503

9. Remove retaining ring (6) (not shown).
10. Use Tooling (C) in order to remove planetary gear (7) .



11. Remove retaining ring (8) and bearing (9) .
12. Repeat Steps 9 through 11 for the remaining planetary gears.

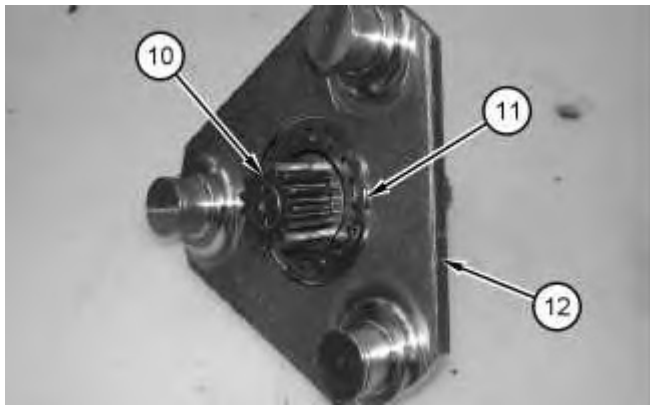

Illustration 7

g01139506

13. Remove retaining ring (11) and shaft (10) from carrier (12) .

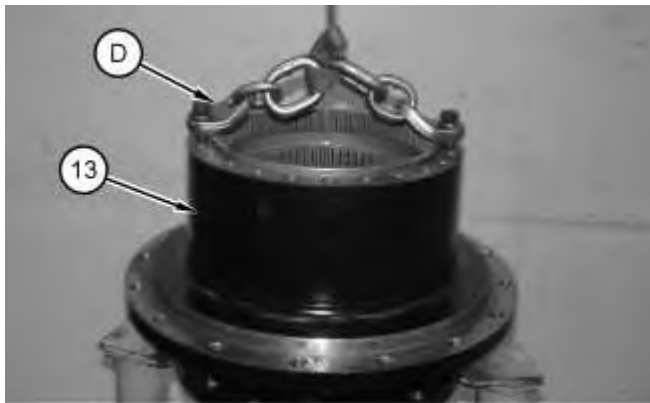

Illustration 8

g01139507

14. Use Tooling (D) to remove ring gear (13). The weight of ring gear (13) is approximately 32 kg (70 lb).
-

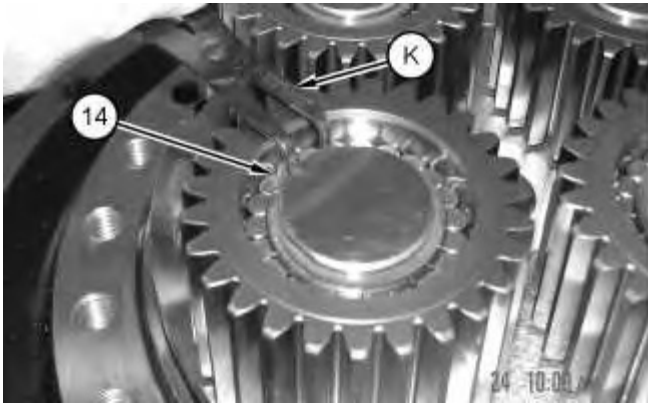

Illustration 9

g01139508

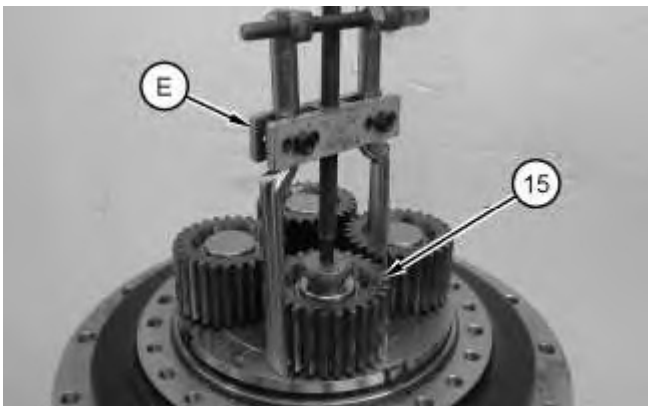

Illustration 10

g01139509

15. Use Tooling (K) in order to remove retaining ring (14) .
16. Use Tooling (E) in order to remove planetary gear (15) .

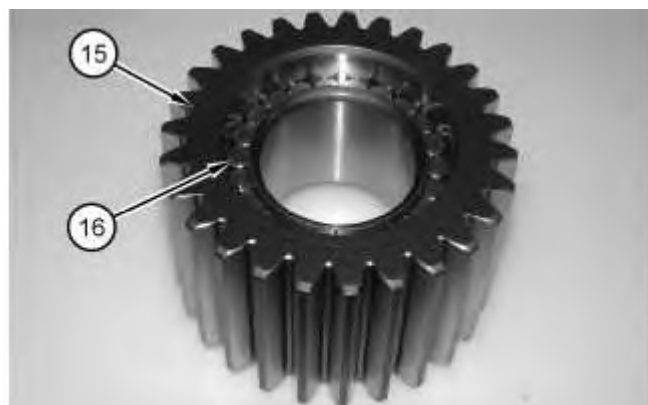

Illustration 11

g01139510

17. Use a suitable press in order to remove bearings (16) from gear (15) .

**Note:** If the bearings are removed, the bearings must be replaced with new bearings.

18. Repeat Steps 15 through 17 for the remaining planetary gears.

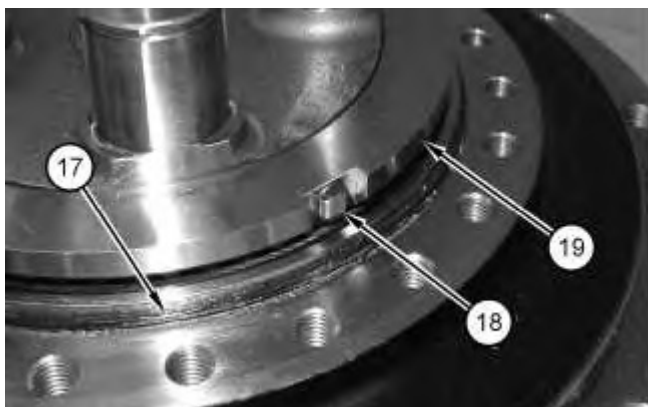

Illustration 12

g01139511

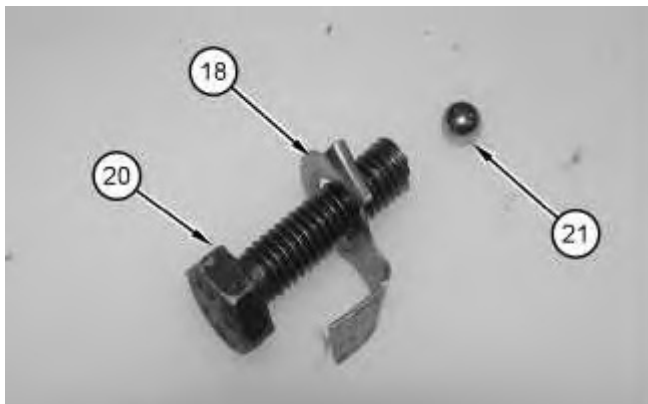

Illustration 13

g01139513

19. Remove O-ring seal (17) .

20. Straighten the tab on lock washers (18) .

21. Remove bolts (20), lock washers (18), and balls (21) from bearing retainer nut (19) .

---

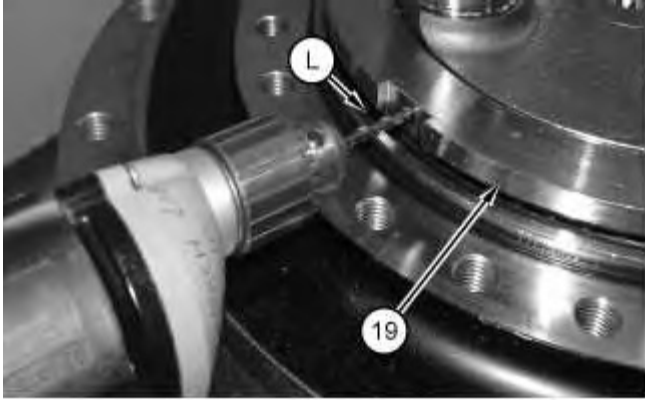

Illustration 14

g01139514

22. Use Tooling (L) to clean the threads in the housing. Remove approximately 2.0 mm (0.08 inch) of material from the housing. This is done in order to prevent the retaining nut threads from being damaged when retaining nut (19) is removed.

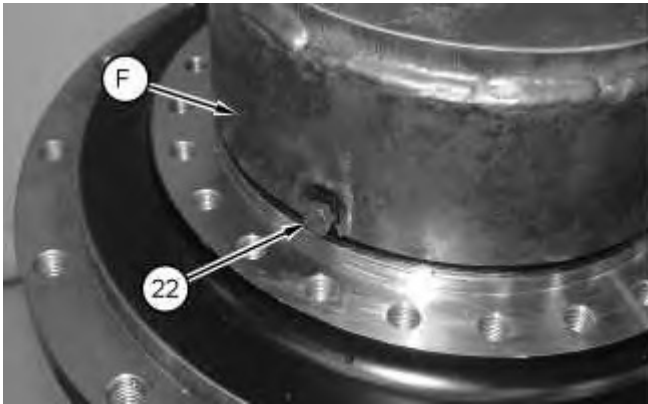
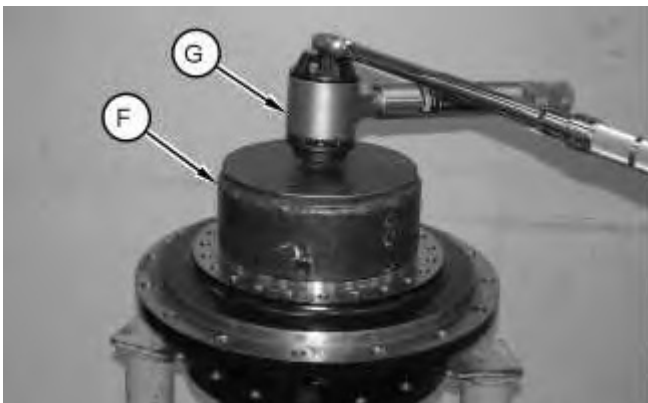

Illustration 15

g01139515

23. Install Tooling (F) on retainer nut (19). Install bolts (22) through Tooling (F) and into the drilled holes in retainer nut (19) .



24. Install Tooling (F), (G), and (H) (not shown).

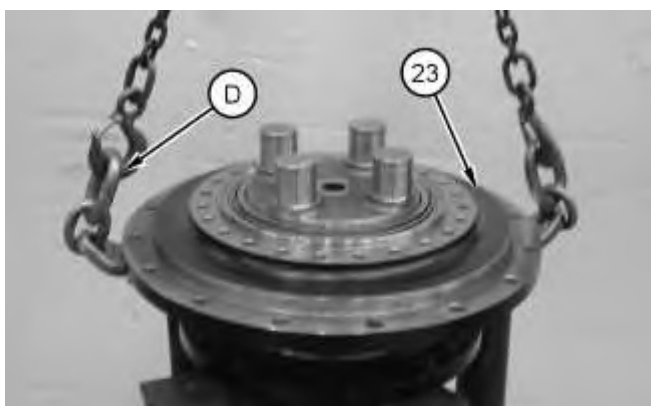

Illustration 17

25. Use Tooling (D) and a suitable lifting device in order to remove support ring (23). The weight of support ring (23) is approximately 23 kg (50 lb).



Illustration 18

26. Remove bearing cone (24) from support ring (23) .
-



Illustration 19

g01139775

27. Remove Duo-Cone seal (25) from support ring (23) .



Illustration 20

g01139776

28. Remove bearing cups (26) .



Illustration 21

g01139777

29. Remove bearing cone (27) from housing (28) .



Illustration 22

g01139778

30. Remove Duo-Cone seal (29) from housing (28) .

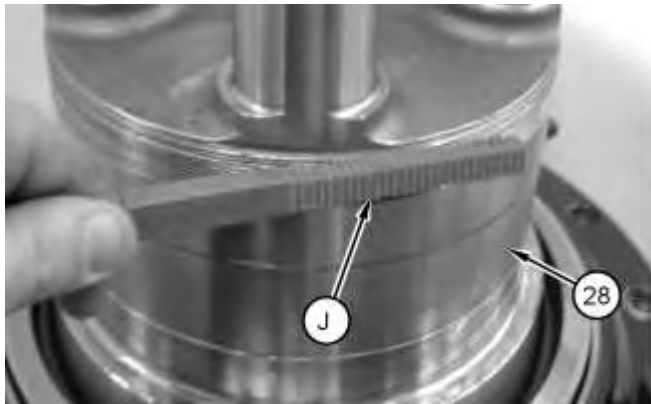

Illustration 23

g01139779

31. Use Tooling (J) in order to repair any damaged threads on housing (28) .

[Previous Screen](#)

Product: EXCAVATOR

Model: 318C EXCAVATOR BTG

Configuration: 318C Excavators BTG00001-UP (MACHINE) POWERED BY 3066 Engine

## Disassembly and Assembly 318C Excavator Machine Systems

Media Number -REN6647-04

Publication Date -01/03/2009

Date Updated -05/03/2009

i02275024

## Final Drive - Assemble

SMCS - 4050-016

S/N - BTG1-UP

S/N - DAH1-UP

S/N - FAA1-UP

## Assembly Procedure

Table 1

Required Tools			
Tool	Part Number	Part Description	Qty
A	1P-2420	Transmission Repair Stand	1
D	138-7576	Link Bracket	2
F	246-7504	Socket	1
G	6V-6080	Torque Multiplier Gp	1
	9U-5006	Torque Wrench	1
H	FT-2993	Reaction Bar	1
K	1P-1864	Retaining Ring Pliers As	1
M	1U-6396	O-Ring Assembly Compound	1
N	1U-6434	Duo-Cone Seal Installer As	1
P	246-7503	Punch	1

**Note:** Cleanliness is an important factor. Before assembly, all parts should be thoroughly cleaned in cleaning fluid. Allow the parts to air dry. Wiping cloths or rags should not be used to dry parts. Lint may be deposited on the parts which may cause later trouble. Inspect all parts. If any parts are worn or damaged, use new parts for replacement. All disassembly and all assembly procedures must be performed on a clean work surface and in a clean hydraulic area. Keep cleaned parts covered and protected at all times.

**Note:** O-rings, gaskets, and seals should always be replaced. A used O-ring seal may not have the same sealing properties as a new O-ring seal. Use Tooling (M) during the assembly procedure.



Illustration 1

g01139778

1. Use Tooling (N) to install Duo-Cone seal (29) onto housing (28) .



Illustration 2

g01139777

2. Install bearing cone (27) onto housing (28) .
-

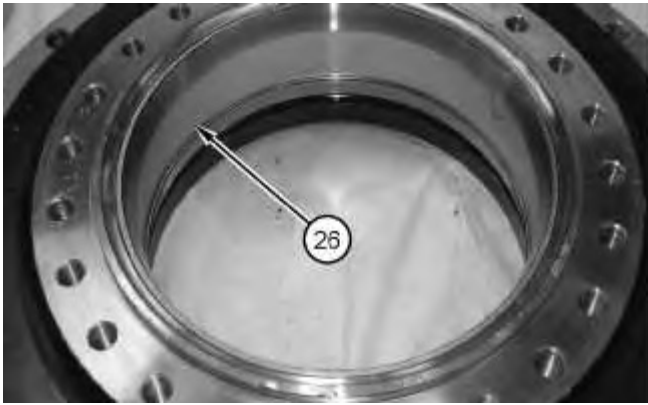

Illustration 3

g01139776

3. Lower the temperature of bearing cups (26). Install bearing cups (26) into support ring (23) .



Illustration 4

g01139775

4. Use Tooling (N) to install Duo-Cone seal (25) into support ring (23) .

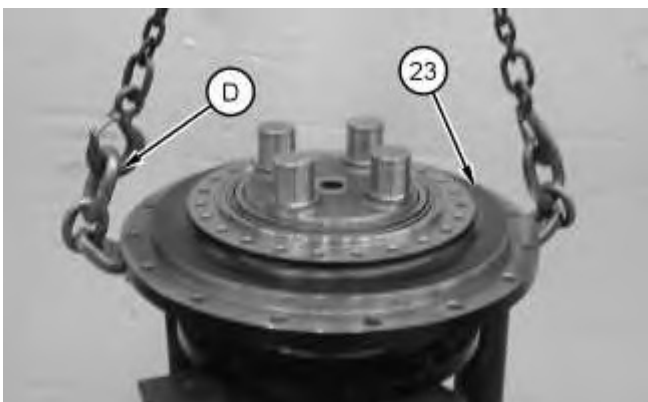

Illustration 5

g01139519

5. Use Tooling (D) and a suitable lifting device in order to install support ring (23) onto housing (28) .



Illustration 6

g01140214

6. Install bearing cone (24), as shown.



Illustration 7

g01140215

7. Install retainer nut (19) .
-

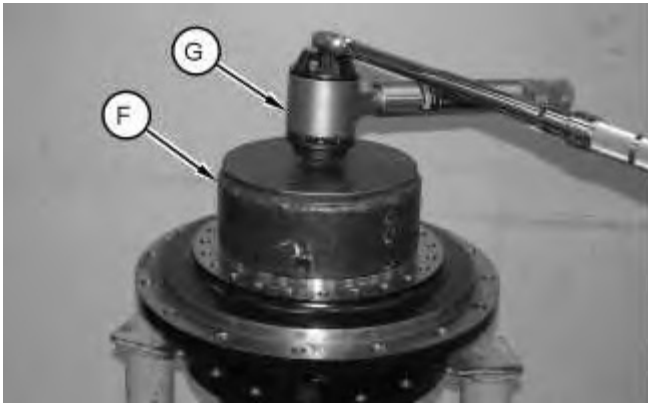

Illustration 8

g01139518

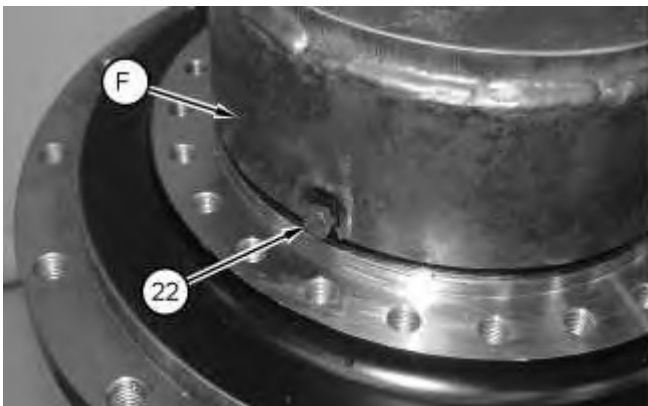

Illustration 9

g01139515

8. Install Tooling (F), (G), and (H) (not shown).
9. Install bolts (22) through Tooling (F) and into retainer nut (19). Tighten retainer nut (19) to a torque of 3500 N·m (2581 lb ft).



Illustration 10

g01140089

10. Use Tooling (P) and a suitable hammer to make a dimple 0.9 mm to 1.25 mm (0.04 to 0.050 inch) deep in housing (28) .

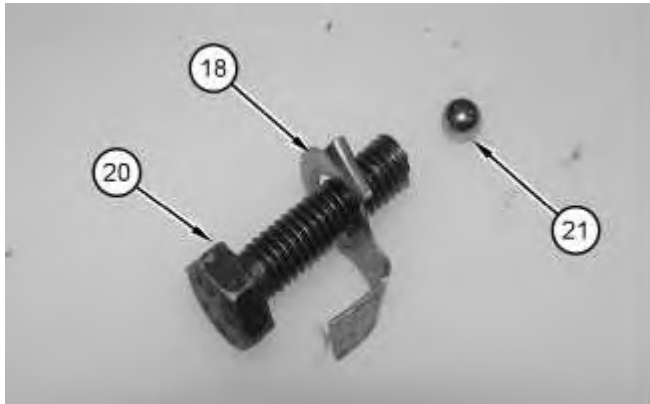

Illustration 11

g01139513

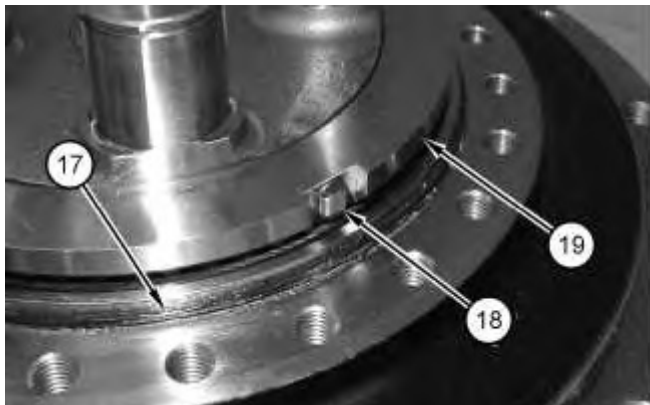

Illustration 12

g01139511

11. Install balls (21), lock washers (18), and bolts (20) .
  12. Fold the tab on lock washers (18) over bolts (20), as shown.
  13. Install O-ring seal (17) .
-

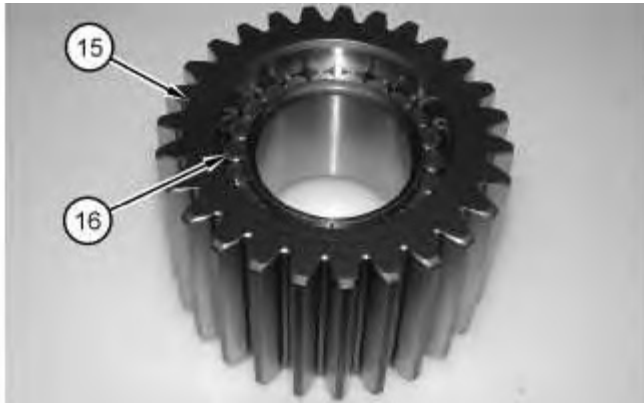

Illustration 13

g01139510

14. Install bearing (16) into gear (15) .



Illustration 14

g01140222

15. Raise the temperature of gear (15). Install gear (15) onto housing (28) .

**Note:** Make sure that the chamfered side of the bearing is installed against the carrier.

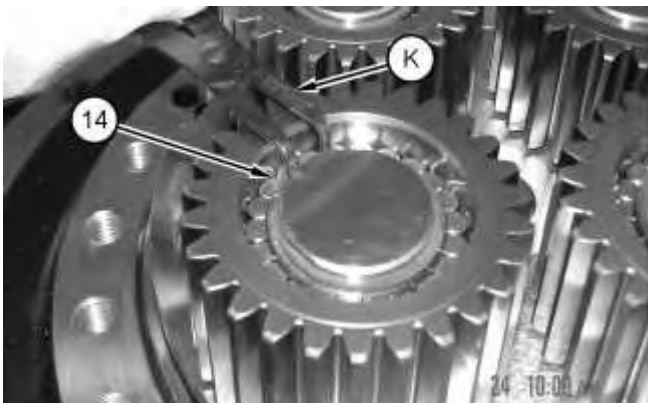

Illustration 15

g01139508

16. Use Tooling (K) to install retaining ring (14) .
17. Repeat Steps 14 through 16 for the other two gears.

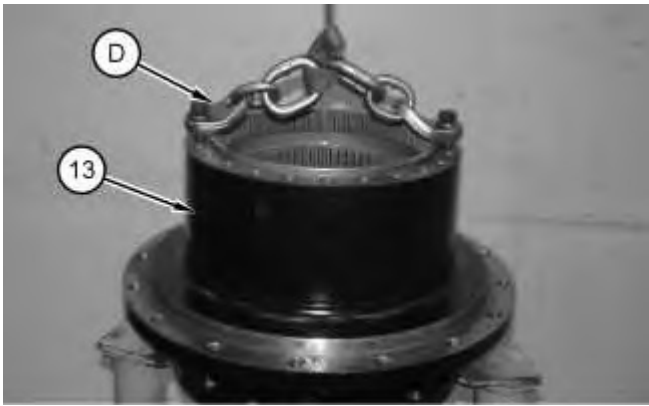

Illustration 16

g01139507

18. Use Tooling (D) and a suitable lifting device in order to install ring gear (13) onto housing (28). The weight of ring gear (13) is approximately 32 kg (70 lb).

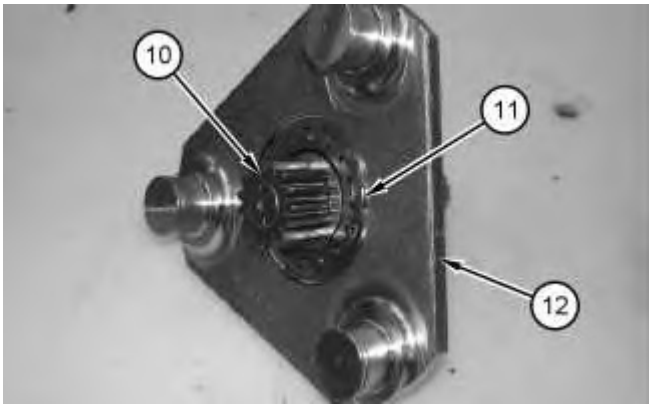

Illustration 17

g01139506

19. Install shaft (10) and retaining ring (11) onto carrier (12) .
-



Illustration 18

g01139504

20. Install bearing (9) and retaining ring (8) into the planetary gear.

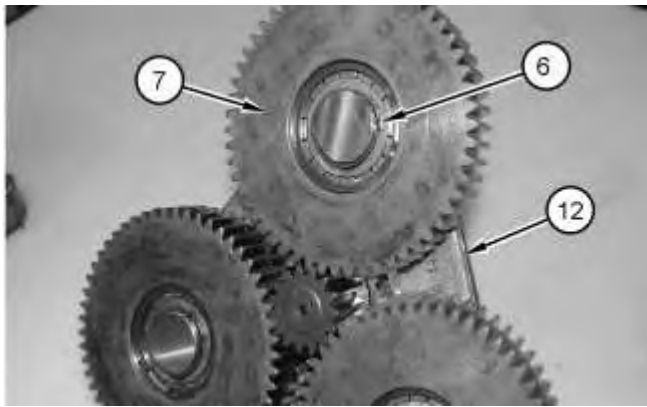

Illustration 19

g01139889

21. Raise the temperature of planetary gear assembly (7). Install planetary gear assembly (7) onto carrier (12) and install retaining ring (6) .
22. Repeat Steps 20 through 21 for the remaining two gears.



23. Install planetary assembly (4) into the final drive housing.
24. Install O-ring seal (5) .

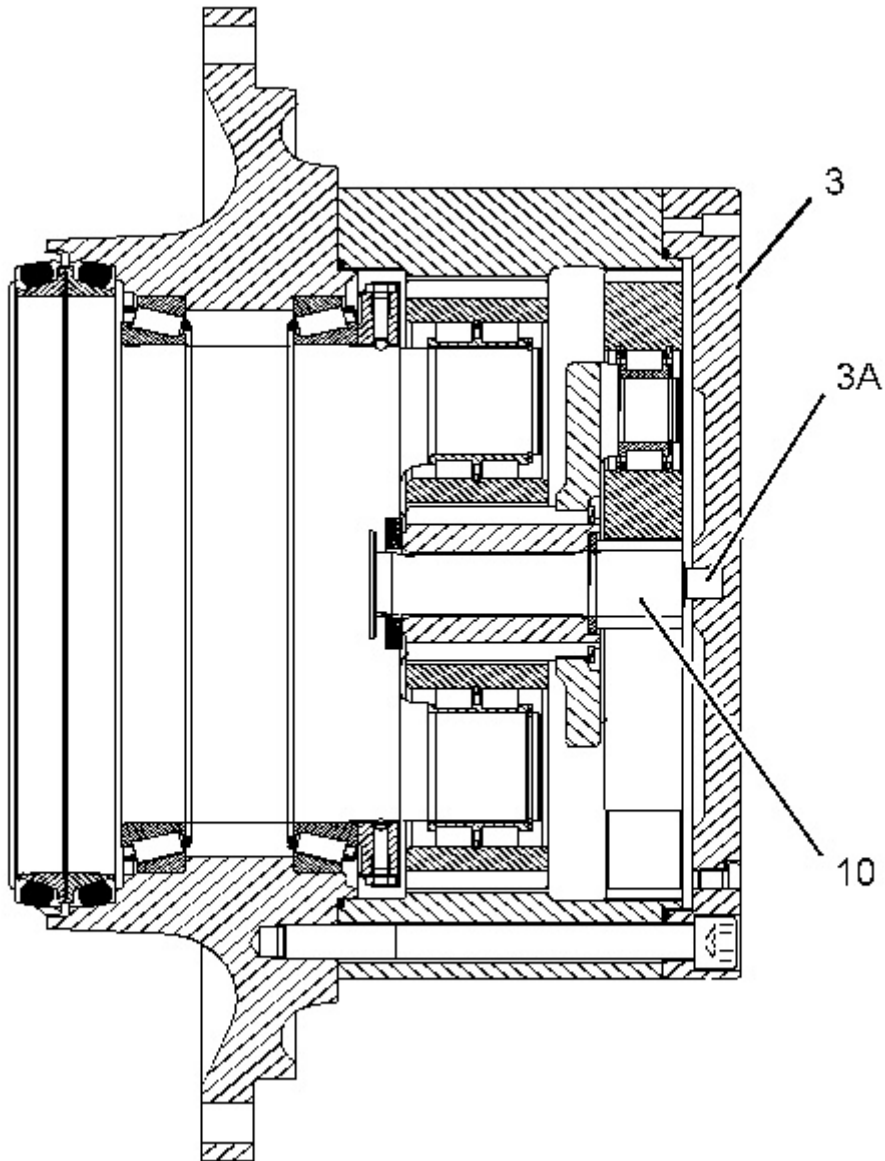

25. Measure the distance between thrust button (3A) and shaft (10). The distance between shaft (10) and thrust button (3A) should be  $1.0 \pm 0.5$  mm ( $0.04 \pm 0.02$  inch).
-

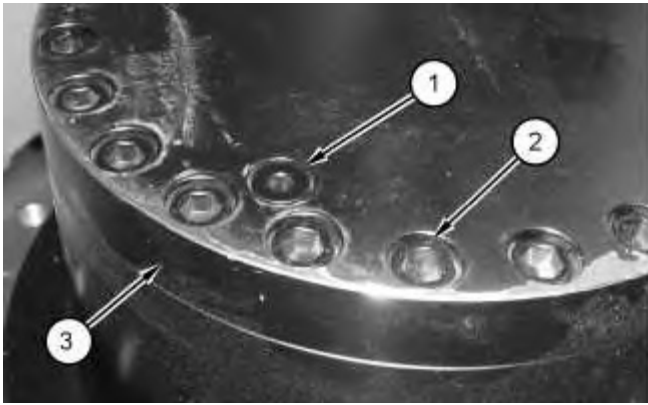

Illustration 22

g01139910

26. Install cover (3) and bolts (2). Tighten bolts (2) evenly to a torque of  $295 \pm 50 \text{ N}\cdot\text{m}$  ( $218 \pm 37 \text{ lb ft}$ ).
27. Install drain plugs (1). Tighten drain plugs (1) to a torque of  $40 \pm 5 \text{ N}\cdot\text{m}$  ( $30 \pm 4 \text{ lb ft}$ ).
28. Make sure that the final drive is filled with oil before the final drive is put back into service. Refer to Operation and Maintenance Manual, "Capacities (Refill)".
29. Install the final drive sprocket if the sprocket was removed from the main housing. Refer to Disassembly and Assembly, "Final Drive Sprocket - Remove and Install" in this manual for the installation of the final drive sprocket.
30. Remove the final drive from Tooling (A). The weight of the final drive is approximately 250 kg (550 lb).

**End By:** Install the final drive. Refer to Disassembly and Assembly, "Final Drive - Install".

[Previous Screen](#)

Product: EXCAVATOR

Model: 318C EXCAVATOR BTG

Configuration: 318C Excavators BTG00001-UP (MACHINE) POWERED BY 3066 Engine

## Disassembly and Assembly 318C Excavator Machine Systems

Media Number -REN6647-04

Publication Date -01/03/2009

Date Updated -05/03/2009

i07192988

# Final Drive - Install

SMCS - 4050-012

## Installation Procedure

Table 1

Required Tools			
Tool	Part Number	Part Description	Qty
A	8S-7611	Handle As	2
	8S-7615	Pin As	2
	283-1495	Stand Assembly	2
B	439-3939	Link Bracket As	2
C	-	Loctite C5A Copper Anti-Seize	-

Table 2

Torque Values of Bolts (3)	
Bolt Size	Torque
M16	90 ± 15 N·m (66 ± 11 lb ft) and turn an additional angle of 60 ± 5 degrees.
M20	150 ± 25 N·m (111 ± 18 lb ft) and turn an additional angle of 55 ± 5 degrees.
M24	250 ± 25 N·m (184 ± 18 lb ft) and turn an additional angle of 45 ± 5 degrees.
M30	500 ± 50 N·m (369 ± 37 lb ft) and turn an additional angle of 50 ± 5 degrees.



**Suggest:**

**If the above button click is invalid.**

**Please download this document**

**first, and then click the above link**

**to download the complete manual.**

**Thank you so much for reading**

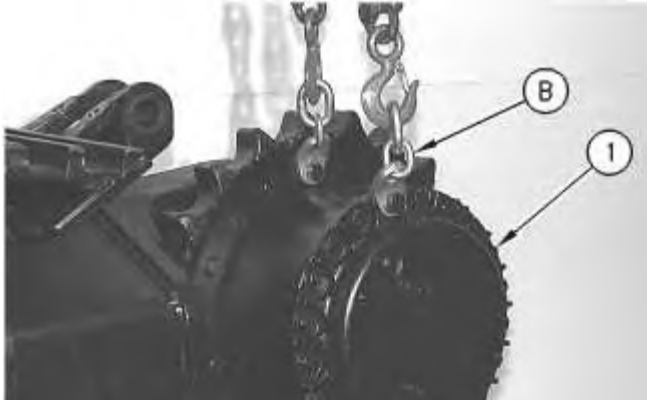

Illustration 1

g00712767

1. Attach Tooling (B) and a suitable lifting device to final drive (1). The weight of final drive (1) and the sprocket is approximately 312 kg (688 lb). Position the final drive in the frame.

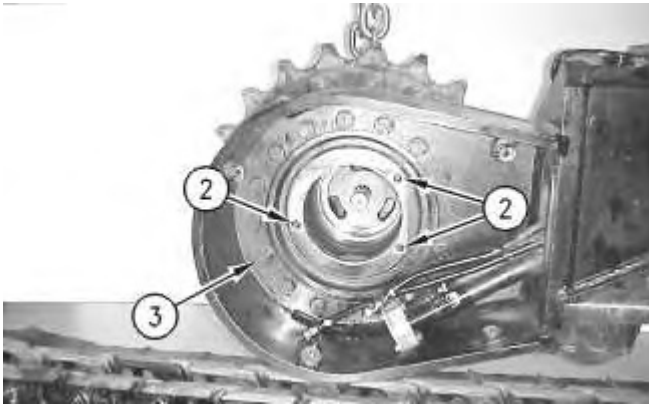

Illustration 2

g00712737

**Note:** Make sure that bolt holes (2) for the travel motor are in the correct position.

**Note:** Make sure that bolts (3), the washers, the motor housing, and the frame are clean and free of protective coating and oil.

2. Before assembly remove all compounds, oil, and dust from the female threads.
3. Apply Tooling (C) to the threads of bolt (3). Install bolts (3) and the washers in the final drive. Tighten bolts (3) to a torque specified in Table 2.
4. Refer to Service Magazine, M0083843, "An Improved Bolt Tightening Procedure for the Critical Joints Is Now Used on All Excavators" for more detail information.
5. Remove Tooling (B) and the suitable lifting device from the final drive.

**<https://www.ebooklibonline.com>**

Hello dear friend!

Thank you very much for reading.

Enter the link into your browser.

The full manual is available for immediate download.

**<https://www.ebooklibonline.com>**