



Service Repair Manual

Models

316F L Excavator

Previous Screen

Product: EXCAVATOR

Model: 316F L EXCAVATOR YDL

Configuration: 316F L Excavator YDL00001-UP (MACHINE) POWERED BY C4.4 Engine

Disassembly and Assembly
316F, 318F Excavator Machine Systems

Media Number -UENR5585-06

Publication Date -01/08/2015

Date Updated -12/09/2018

i07186488

Final Drive

SMCS - 4050

Specifications

Note: Callouts in the Specifications section do not match the callouts in the Remove and Install sections.

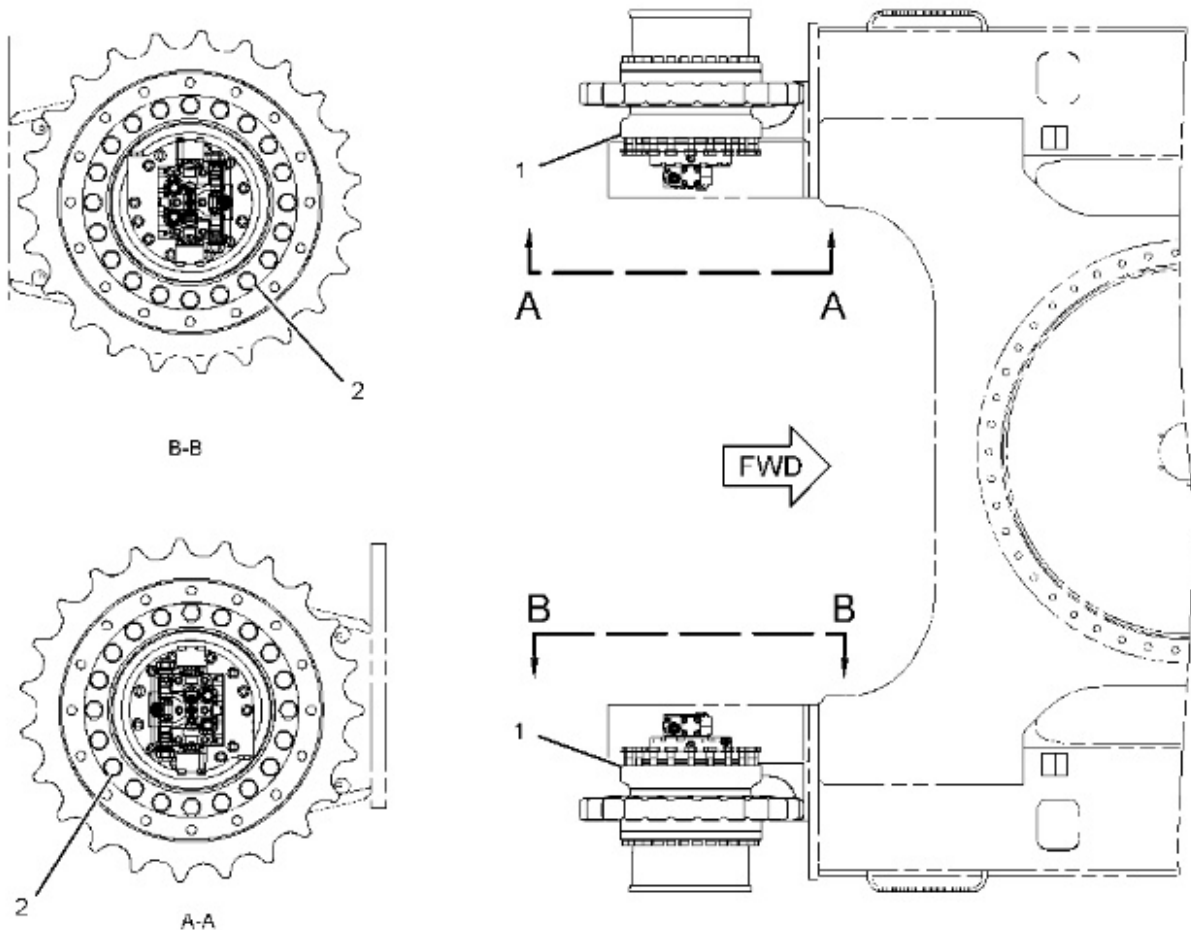

Top view

Table 1

Specification for 333-3002 Final Drive and Mounting Gp			
Item	Qty	Part	Specification Description
1	-	-	Before assembly, the surfaces must be clean and free of any protective coating.
2	40	461-3873 Bolt	Apply Loctite C5A Copper Anti-Seize to threads. Torque to $90 \pm 15 \text{ N}\cdot\text{m}$ ($66 \pm 11 \text{ lb ft}$). Turn an additional angle of 60 ± 5 degrees.

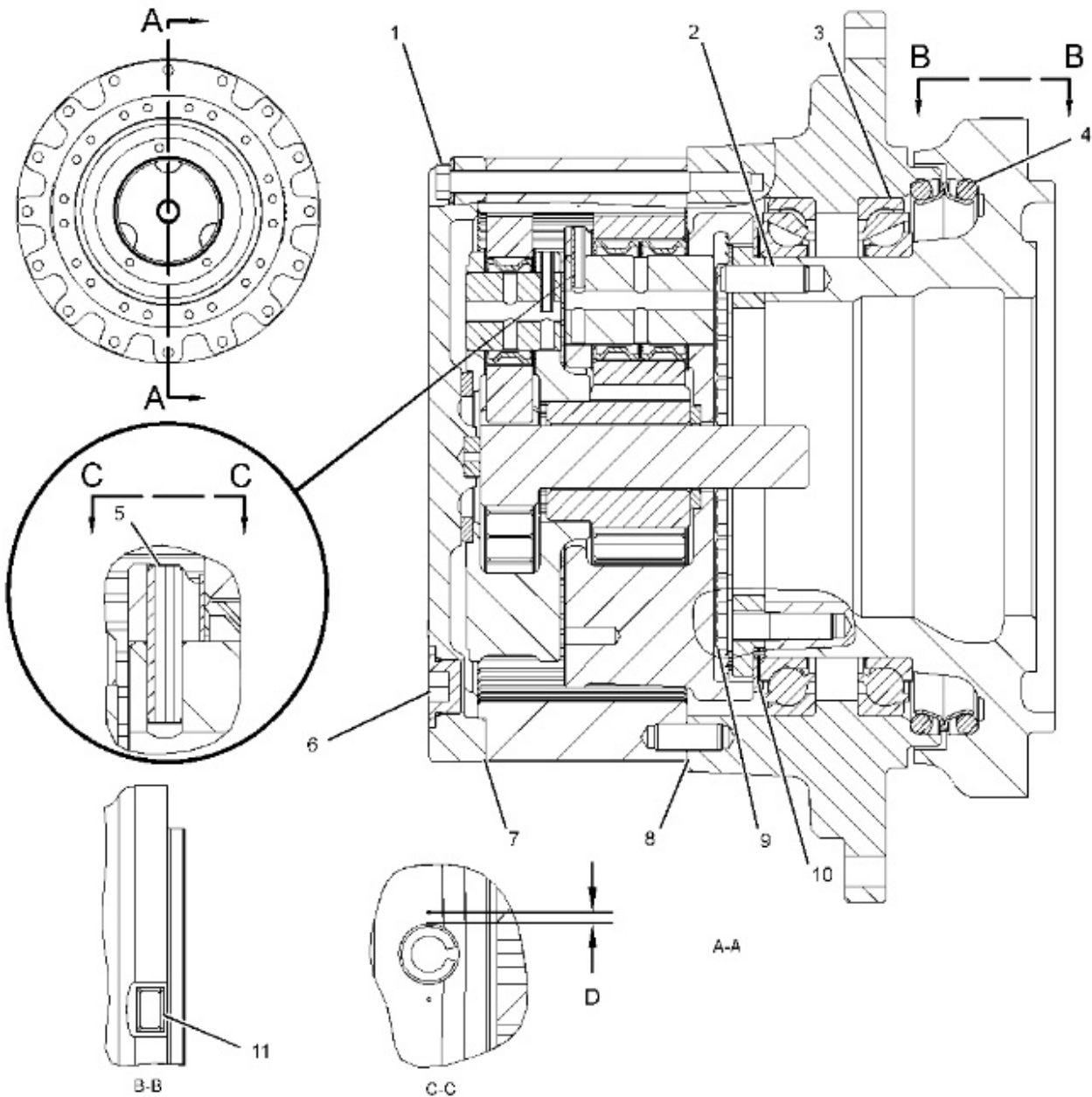

<https://www.ebooklibonline.com>

Hello dear friend!

Thank you very much for reading.

Enter the link into your browser.

The full manual is available for immediate download.

<https://www.ebooklibonline.com>

Table 2

Specification for 350-0452 Final Drive Gp			
Item	Qty	Part	Specification Description
1	16	8T-7929 Bolt	Apply red Loctite 271 to the threads. Torque to 105 ± 20 N·m (929 ± 177 lb in).
2	4	114-1539 Dowel Pin	Apply Loctite C5A Copper Anti-Seize to the inside diameter and outside diameter of the mating parts.
3	2	296-6220 Ball Bearing	Apply Loctite C5A Copper Anti-Seize to the inside diameter and outside diameter of the mating parts.
4	1	174-4874 Duo-Cone Seal Gp	Rubber toric seals and all surfaces that in contact with the seals must be clean and dry at assembly. Prior to assembly apply, a thin layer of 6V-4876 Lubricant to the surfaces that are in contact with the metal seals. The metal seal must be assembled square with the bore. The rubber toric seals must not bulge. The rubber toric seals must not be twisted.
5	6	095-0891 Spring Pin	After installation of the spring pins (5), create two stake marks for each pin slightly near the hole of spring pins. Refer to Illustration 2 for the locations of the stake marks.
6	2	3E-2338 Pipe Plug	Torque to 80 ± 10 N·m (59 ± 7 lb ft).
7	1	165-5790 Cover	Before assembly, apply 8C-8422 Sealant to the mating surfaces of the cover.
8	1	165-3892 Ring Gear	Before assembly, apply 8C-8422 Sealant to the mating surfaces of the ring gear.
9	16	227-6034 Bolt	Torque to 270 ± 40 N·m (199 ± 30 lb ft).
10	As required, use the following shims to achieve the correct clearance between the ball bearing and the coupling gear. If two shims (10) are required, install the thinnest shim next to the coupling gear:		
	1	096-1773 Shim	Thickness is 0.15 mm (0.006 inch).
	1	096-1774 Shim	Thickness is 0.30 mm (0.012 inch).
	1	096-1775 Shim	Thickness is 0.40 mm (0.016 inch).
	1	096-1776 Shim	Thickness is 0.50 mm (0.020 inch).
	1	096-1777 Shim	Thickness is 0.60 mm (0.024 inch).
	1	096-1778 Shim	Thickness is 0.70 mm (0.028 inch).

	1	096-1779 Shim	Thickness is 0.80 mm (0.031 inch).
	1	096-1780 Shim	Thickness is 1.00 mm (0.039 inch).
	1	096-1781 Shim	Thickness is 1.60 mm (0.063 inch).
D	-	-	The distance from the edge of the spring pin hole to the stake mark is 1.5 mm (0.06 inch).
11	1	354-4318 Nameplate	Apply Loctite 330 or activator 738 to the surface of the nameplate.

Removal Procedure

Table 3

Required Tools			
Tool	Part Number	Part Description	Qty
A	8S-7640	Stand	2
	8S-7611	Tube	2
	8S-7615	Pin	2
B	439-3939	Link Bracket As	2
C	154-6184	Forcing Bolt (M 20)	2

Start By:

- a. Separate the track assembly. Refer to Disassembly and Assembly, "Track - Separate".
- b. Remove the travel motor. Refer to Disassembly and Assembly, "Travel Motor - Remove".



Illustration 3

g00489826

Note: Adjust the height of Tooling (A) so that there is sufficient clearance between the sprocket and the track for the removal of the final drive.

1. Lift the side of the machine to install Tooling (A) under the frame, as shown.

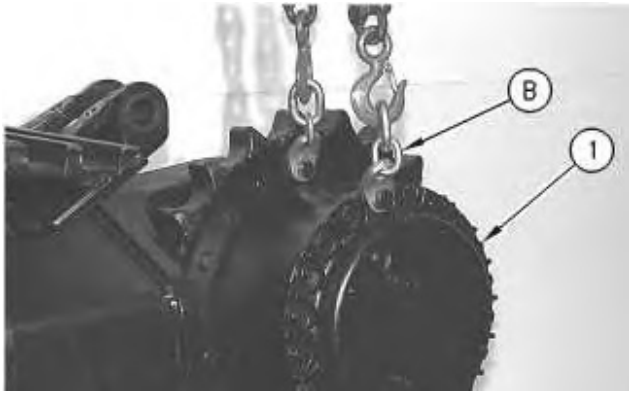

Illustration 4

g00712767

2. Fasten Tooling (B) and a suitable lifting device to final drive (1), as shown. Put a slight lifting tension on the final drive.

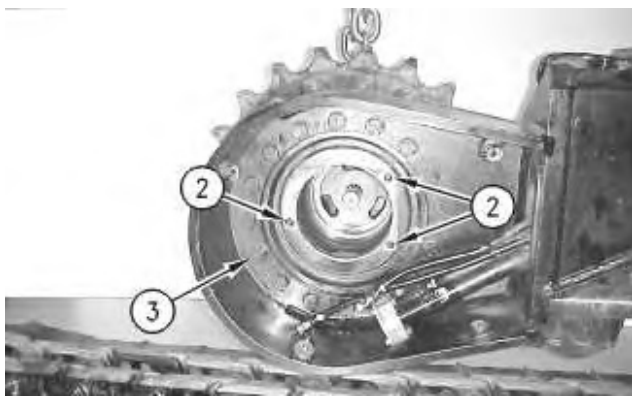

Illustration 5

g00712737

Note: Mark the orientation of bolt holes (2) for the travel motor for installation purposes.

3. Remove bolts (3) and the washers from the final drive.

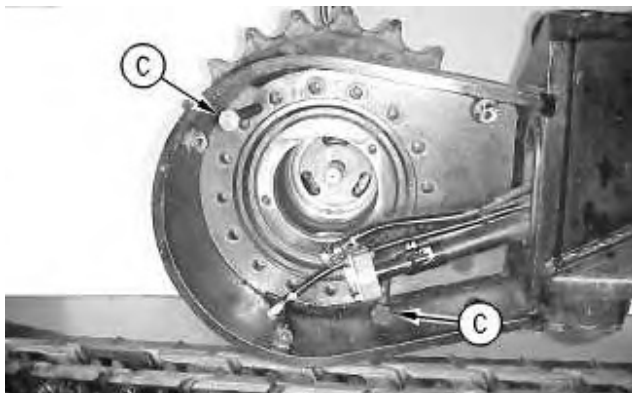

Illustration 6

g00712749

4. Use Tooling (C) to remove the final drive from the frame.

5. Carefully remove final drive (1). The weight of final drive (1) and the sprocket is approximately 312 kg (688 lb).
6. Remove Tooling (C) from the frame.

Disassembly Procedure

Table 4

Required Tools			
Tool	Part Number	Part Description	Qty
A	1P-2420	Transmission Repair Stand	1
B	439-3938	Link Bracket	2
C	1P-1863	Retaining Ring Pliers	1
D	439-3940	Bracket As	3
E	4C-8359	Eyebolt	2
F	439-3939	Link Bracket As	2
G	439-3941	Link Bracket As	2

Start By:

- a. Remove the final drive.

Note: Cleanliness is an important factor. Before the disassembly procedure, the exterior of the component should be thoroughly cleaned. This will prevent dirt from entering the internal mechanism.

1. Put an alignment mark across the sections of the final drive for assembly purposes. The parts must be reinstalled to the original locations.



Illustration 7

g00892878

2. Use Tooling (G) and a suitable lifting device to position the final drive assembly onto Tooling (A). The weight of the final drive assembly is approximately 550 kg (1200 lb).
3. Remove bolts (1).

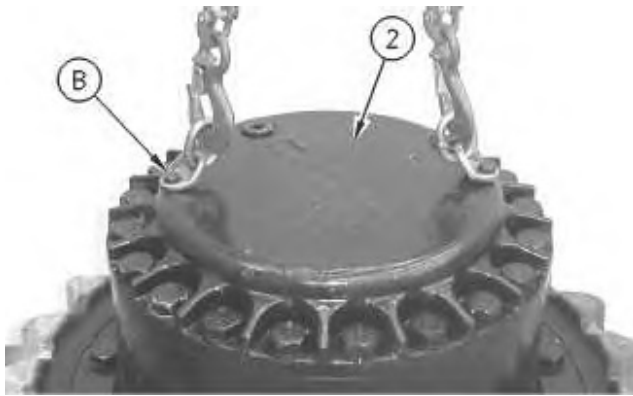

Illustration 8

g00892883

4. Use Tooling (B) and a suitable lifting device to remove cover (2). The weight of cover (2) is approximately 32 kg (70 lb).

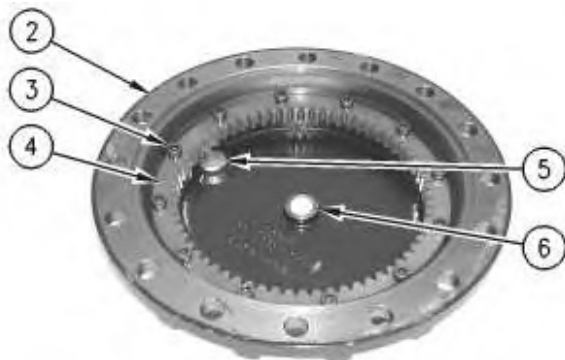

Illustration 9

g00892888

5. Remove bolts (3) and gear (4). Check plate (6). Replace plate (6) if plate (6) is worn. Remove plugs (5) from cover (2).



Illustration 10

g00892906

6. Remove O-ring seals (7) from plugs (5).
-



Illustration 11

g00892930

7. Remove gear (8) and spacer (9).



Illustration 12

g00892965

8. Use Tooling (C) to remove retaining ring (10). Remove washer (11) and gear (12). Remove bearing assembly (13) and washer (14).
9. Repeat Step 8 for the other two gear assemblies.

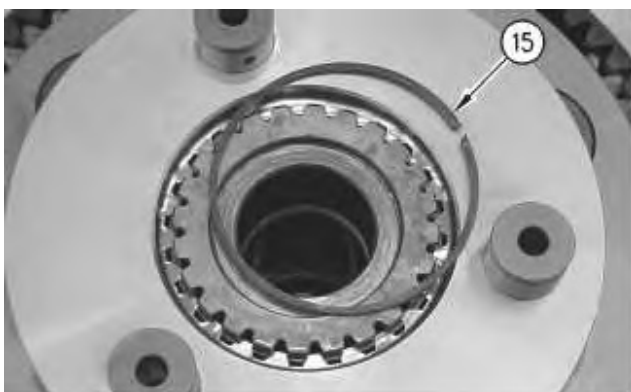

Illustration 13

g00892968

10. Remove retaining ring (15).

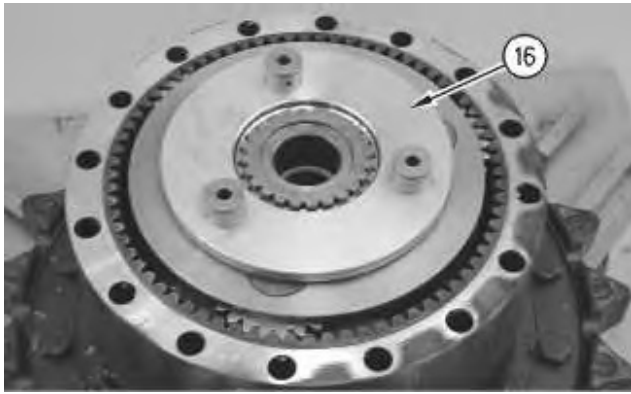

Illustration 14

g00892975

11. Remove carrier assembly (16).

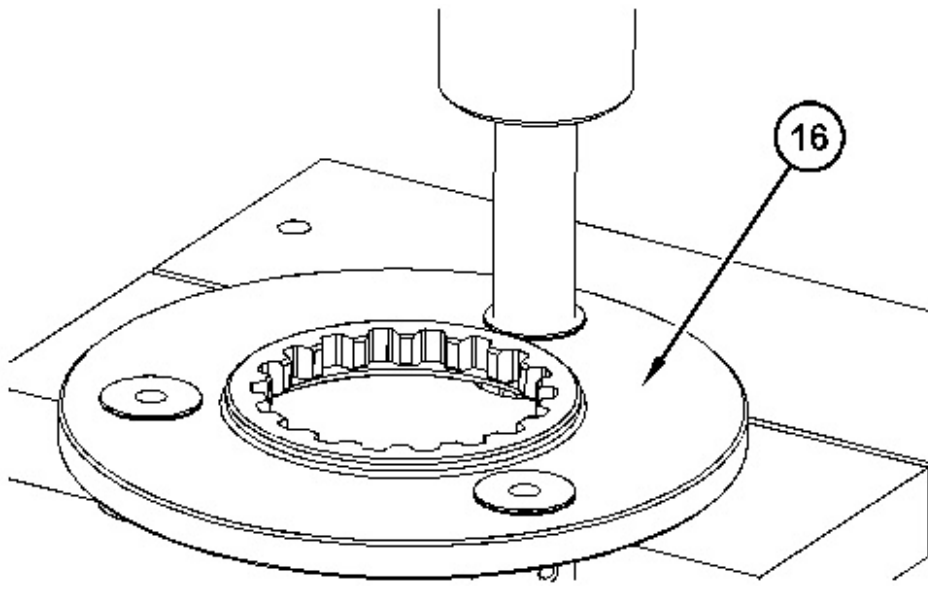

Illustration 15

g02408860

12. Use a suitable press to remove the shafts from carrier assembly (16).

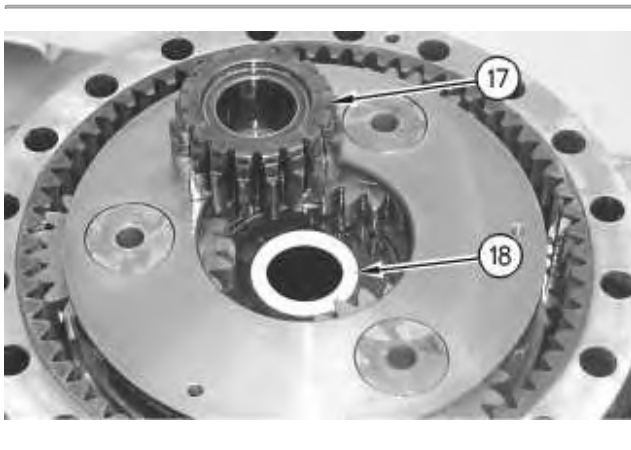

Illustration 16

g00892977

13. Remove gear (17) and spacer (18).

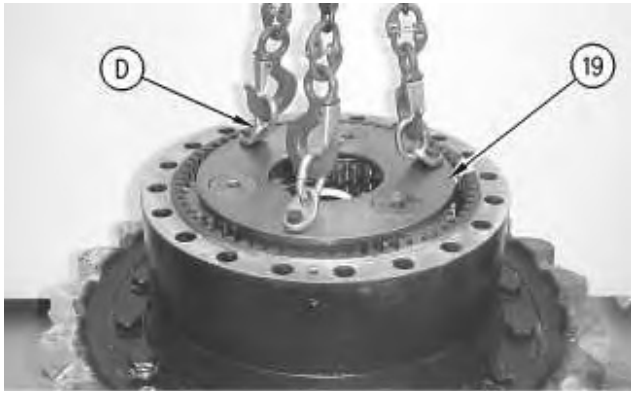

Illustration 17

g00892997

14. Use Tooling (D) and a suitable lifting device to remove planetary carrier (19). The weight of planetary carrier (19) is approximately 48 kg (105 lb).

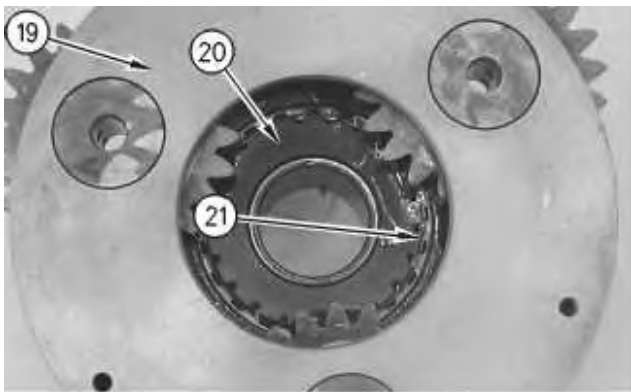

Illustration 18

g00893019

15. Remove retaining ring (21). Lift planetary carrier (19) off sun gear (20).



Illustration 19

g00896860

16. Drive spring pin (23) into planetary shaft (22).
-

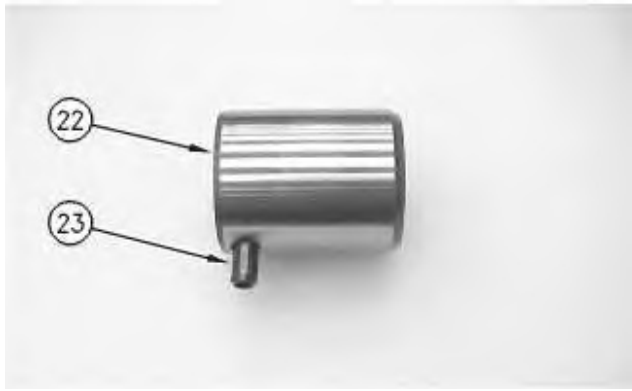

Illustration 20

g00893043

17. Remove planetary shaft (22). Use a suitable punch to remove spring pin (23) from planetary shaft (22).

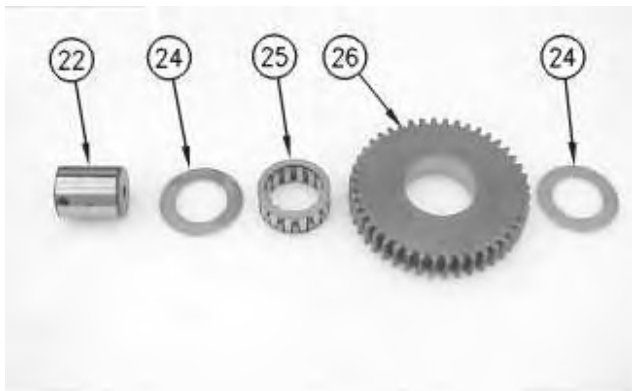

Illustration 21

g00896863

18. Remove washers (24) and bearing (25) from planetary gear (26).
19. Repeat Steps 16 through 18 for the other two planetary gears.

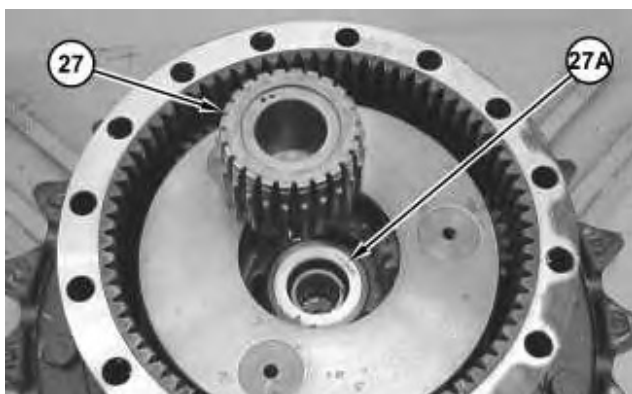

Illustration 22

g01842853

20. Remove gear (27). Remove spacer (27A).

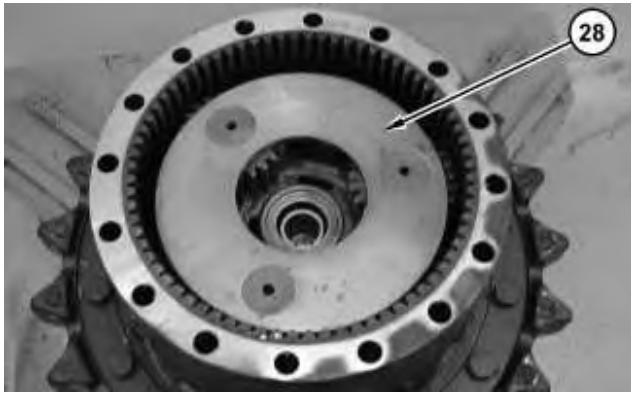

Illustration 23

g01842974

21. Use two people to remove carrier assembly (28). The weight of carrier assembly (28) is approximately 38 kg (85 lb).



Illustration 24

g01843140

22. Drive spring pin (30) into shaft (29).



Illustration 25

g00893658

23. Remove shaft (29). Use a suitable punch to remove spring pin (30) from shaft (29).

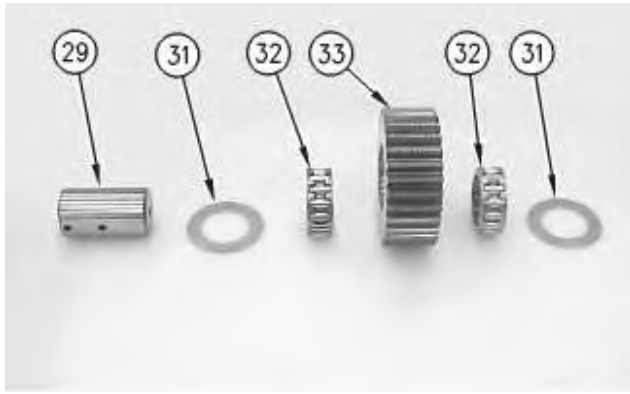

Illustration 26

g00893674

24. Remove washers (31) and bearings (32) from planetary gear (33).
25. Repeat Steps 22 through 24 for the other three planetary gears.



Illustration 27

g01208300

26. Fasten Tooling (E) and a suitable lifting device to ring gear (34), as shown. Remove ring gear (34) from sprocket housing (35). The weight of ring gear (34) is approximately 66 kg (146 lb).



Illustration 28

g01208542

27. Remove O-ring seal (36) from sprocket housing (35).



Illustration 29

g01208553

28. Remove bolts (37) from coupling gear (38).

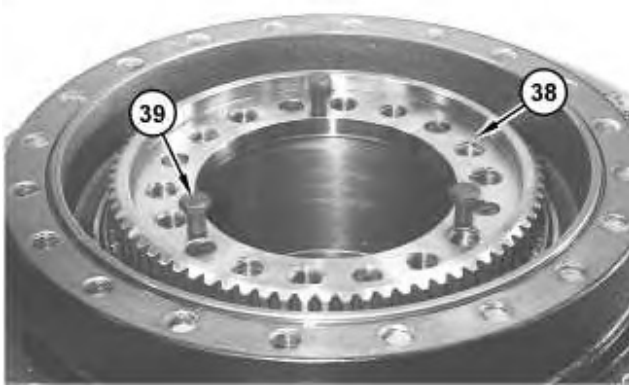

Illustration 30

g01208572

29. Install suitable forcing bolts (39) in coupling gear (38). Tighten the forcing bolts evenly to loosen coupling gear (38). Remove the coupling gear from the motor housing.



Illustration 31

g01208578



Illustration 32

g01208625

30. Remove shims (40) from the motor housing.

Note: Inner cones and outer bearing cones (42) are a slip fit on the motor housing. While you remove sprocket housing (35) from the motor housing, inner bearing cone (42) may stay with the sprocket housing or the inner bearing cone may stay on the motor housing.

31. Fasten Tooling (F) and a suitable lifting device to sprocket housing (35). Separate the sprocket housing from the motor housing. The weight of sprocket housing (35) is approximately 109 kg (240 lb).



Illustration 33

g01208626

32. Remove the locating pins from the motor housing.
 33. Remove Duo-Cone seal (41) from the motor housing.
 34. If inner bearing cone (42) remained on the motor housing, then remove the inner bearing cone.
-



Illustration 34

g01208633

35. Remove Duo-Cone seal (43) from the sprocket housing.
36. If inner bearing cone (42) remained on the sprocket housing, then remove the inner bearing cone.
37. Remove the bearing cups from the sprocket housing.

Assembly Procedure

Table 5

Required Tools			
Tool	Part Number	Part Description	Qty
A	1P-2420	Transmission Stand Group	1
B	439-3938	Link Bracket	2
C	1P-1863	Retaining Ring Pliers	1
D	439-3940	Bracket As	3
E	4C-8359	Eyebolt	2
F	439-3939	Link Bracket As	2
G	8T-9206	Duo-Cone Seal Installer As	1
	169-0503	Installation Kit	1
H	4C-5599	Anti-Seize Compound	-
J	9S-3263	Thread Lock Compound	-
K	8C-8422	Sealant	-
L	FT-2770	Leak down Test Tool	1
M	439-3941	Link Bracket As	2

1. Make sure that all parts of the final drive are thoroughly clean and free of dirt and debris prior to assembly. Check the condition of all O-ring seals that are used in the final drive. If any of

the seals are damaged, use new parts for replacement. Reassemble the final drive on Tooling (A).



Illustration 35

g01208879

2. Apply Tooling (H) to the surfaces inside sprocket housing (35) which comes in contact with the bearing cups. Install a bearing cup that is in each side of the sprocket housing with a press. Make sure that the bearing cups are properly seated.
3. Apply Tooling (H) to the surfaces inside the motor housing that comes in contact with bearing cones (42).
4. Install inner bearing cone (42) on the motor housing.



Illustration 36

g01208625

5. Attach Tooling (F) and a suitable lifting device to sprocket housing (35). The weight of sprocket housing (35) is approximately 109 kg (240 lb). Install sprocket housing (35) on the motor housing. Carefully install outer bearing cone (42) on the sprocket housing.
-



Illustration 37

g01208578

6. Adjust the bearing preload of the final drive. Determine the correct number of shims (40) that are required for the proper bearing preload, as follows:



Illustration 38

g01208987

- Use a depth micrometer to measure the step height of coupling gear (38) at several locations around the gear. Find the average for the measured dimensions around the gear and record the dimension. Call this Dimension (X).
- Apply a load of 4000 kg (8820 lb) to bearing cones (42).
- Rotate sprocket housing (35) several times to seat the bearing cones.
- Reduce the load to 3000 ± 300 kg (6615 ± 660 lb).



- e. While the load is still on the bearing cones, measure the distance between the top face of the motor housing and the top face of bearing cone (42). Take measurements in several locations around the motor housing. Find the average of the measured dimensions, and record the dimensions. Call this Dimension (Y).
- f. Determine the correct thickness of shims (40) which are used between bearing cone (42) and coupling gear (38). Use the following equation to determine the shim pack thickness.

Shim pack thickness ... $(Y) - (X) \pm 0.05 \text{ mm (0.002 inch)}$

Note: If two shims (40) are required, install the thinnest shim next to coupling gear (38) during final assembly.

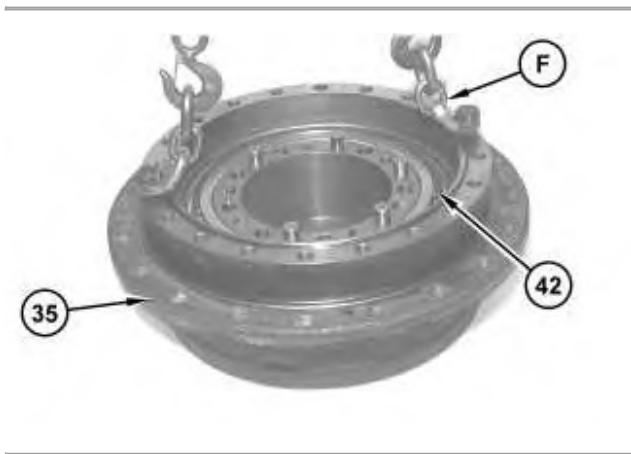

Illustration 40

g01208625

7. Attach Tooling (F) and a suitable lifting device to sprocket housing (35). Separate sprocket housing (35) from the motor housing.

Reference: Refer to Disassembly and Assembly, "Duo-Cone Conventional Seals - Install".

Note: The rubber seals and all surfaces that comes in contact with the seals must be clean and dry. After installation of the seals, put clean SAE 30 oil on the contact surfaces of the metal seals.



Illustration 41

g00631006



Illustration 42

g01208999

8. Use Tooling (G) to install Duo-Cone seal (43) in the sprocket housing.



Illustration 43

g00631014



Illustration 44

g01208626

9. Use Tooling (G) to install Duo-Cone seal (41) in the motor housing.
10. Apply Tooling (H) in the bores for the locating pins that are in the motor housing. Reinstall the locating pins in the motor housing.
-



Illustration 45

g01208625

11. Make sure that inner bearing cone (42) is seated properly on the motor housing.

Note: Do not scratch Duo-Cone seal (41) or damage the Duo-Cone seal in the main housing, or the motor housing during assembly of the two components. After installation of the main housing on the motor housing, there will be a small gap between the components. The gap between the components is caused by the Duo-Cone seal. The gap will be eliminated during the installation of coupling gear (40).

12. Fasten Tooling (F) and a suitable lifting device to sprocket housing (35). Carefully install the sprocket housing on the motor housing.
13. Install outer bearing cone (42) on the sprocket housing. Make sure that the outer bearing cone is properly seated.



Illustration 46

g01208578

14. Install shims (40) that were determined in Steps 6.a through 6.f on the end of the sprocket housing. If shims were required, make sure that the thinnest shim is installed on top.
-



Illustration 47

g01208553

15. Put coupling gear (38) in the original position on the motor housing.
16. Apply Tooling (J) on the threads of bolts (37) that hold coupling gear (38) in position. Tighten bolts (37) evenly and tighten the bolts in diagonally opposite pairs.



Illustration 48

g01208542

17. Install O-ring seal (36) in sprocket housing (35).



Illustration 49

g01208300

18. Thoroughly clean the mating surface of sprocket housing (35) and the mating surface of ring gear (34).

19. Apply a bead of Tooling (K) on the mating surface of ring gear (34).
20. Attach Tooling (E) and a suitable lifting device to ring gear (34). Put ring gear (34) in position on the sprocket housing. The weight of ring gear (34) is approximately 66 kg (146 lb). Make sure that the alignment mark on the sprocket housing and the ring gear line up with each other.



Illustration 50

g01843479

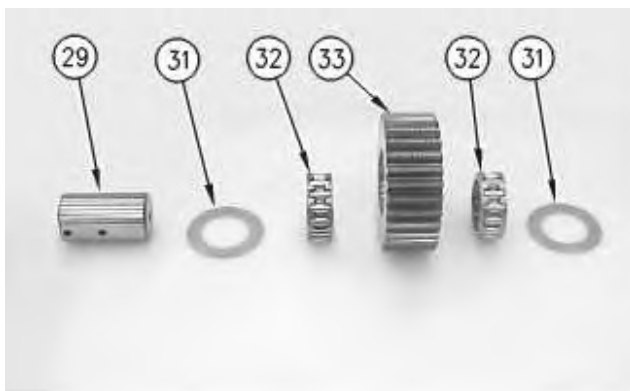

Illustration 51

g00893674

21. Assemble carrier assembly (28), as follows.
 - a. Install bearings (32) in planetary gear (33).
 - b. Install thrust washers (31) and planetary gear (33) in the carrier assembly.
 - c. Use a deburring tool to remove the metal burr from the openings in the carrier. Install planetary shaft (29) in the carrier assembly.
 - d. Drive spring pin (30) into planetary shaft (29).
-

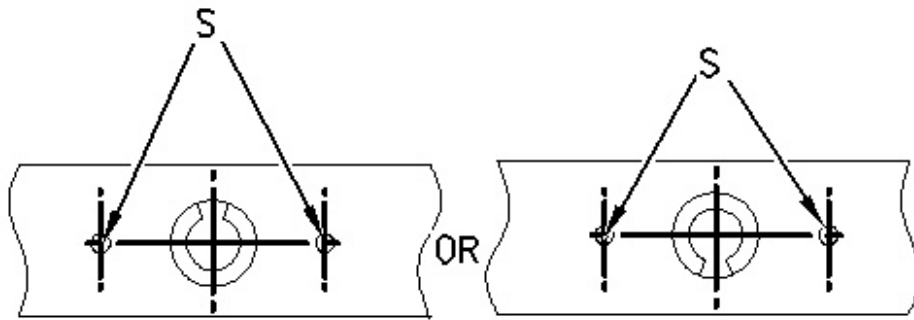

Illustration 52

g00941047

The stake mark is at position (S).

- e. Orient the split in spring pin (30) vertically to the carrier. Align the split in the spring pin to the top or to the bottom. Make a stake mark on each side of the spring pin hole in the carrier. Each stake mark should be approximately 1.5 mm (0.06 inch) from the outside diameter of the spring pin hole.
22. Repeat Steps 21.a through 21.e to install the other two planetary gears in the carrier assembly.



Illustration 53

g01842974

23. Use two people to install carrier assembly (28). The weight of carrier assembly (28) is approximately 38 kg (85 lb).



Suggest:

If the above button click is invalid.

Please download this document

first, and then click the above link

to download the complete manual.

Thank you so much for reading

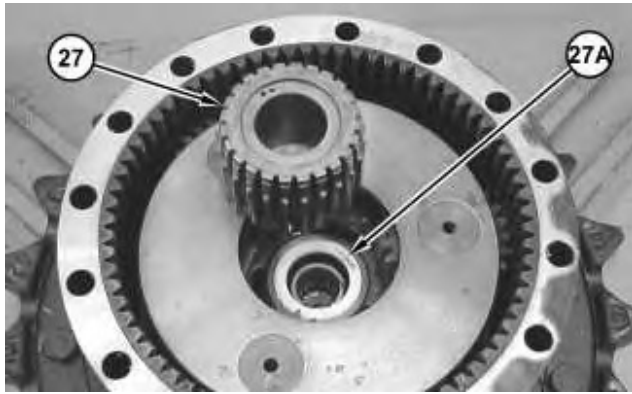

Illustration 54

g01842853

24. Install spacer (27A). Install gear (27).

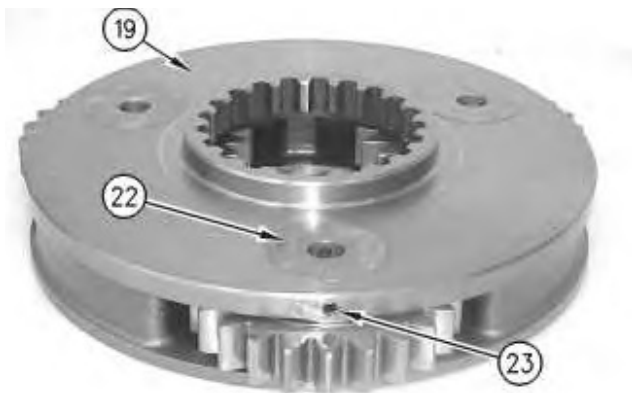

Illustration 55

g00897548

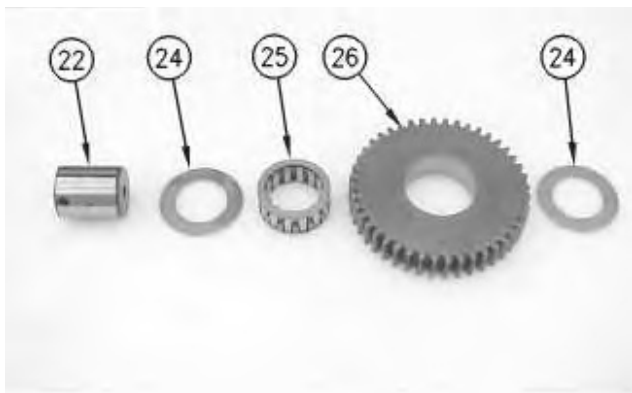

Illustration 56

g00896863

25. Assemble planetary carrier (19), as follows.

- a. Install bearing (25) in planetary gear (26).
- b. Install thrust washers (24) and planetary gear (26) in the planetary carrier.
- c. Use a deburring tool to remove the metal burr from the openings in the carrier. Install planetary shaft (22) in planetary carrier (19).

<https://www.ebooklibonline.com>

Hello dear friend!

Thank you very much for reading.

Enter the link into your browser.

The full manual is available for immediate download.

<https://www.ebooklibonline.com>