



Service Repair Manual

Models

315D L Excavator

[Previous Screen](#)

Product: EXCAVATOR

Model: 315D L EXCAVATOR NCM

Configuration: 315D L Excavator NCM00001-UP (MACHINE) POWERED BY C4.2 Engine

Disassembly and Assembly 315D, 318D and 319D Excavators Machine Systems

Media Number -KENR5272-13

Publication Date -01/09/2017

Date Updated -06/09/2017

i05453130

Final Drive - Disassemble

SMCS - 4050-015

Disassembly Procedure

Table 1

Required Tools			
Tool	Part Number	Part Description	Qty
A	1P-2420	Transmission Repair Stand	1
B	439-3938	Link Bracket	2
C	154-6181	Forcing Bolt	1
D	439-3940	Link Bracket	2
E	5F-7366	Forcing Bolt	1
	1P-5546	Crossblock	1
	1U-9889	Crossblock	1
	1P-0520	Driver Group	1
	6V-7888	Puller Leg	2
	1H-3112	Puller Assembly	1
	1P-5551	Adjustable Screw Assembly	1
F	-	Loctite 5127	1

Start By:

- a. Remove the final drive.

Note: Cleanliness is an important factor. Before the disassembly procedure, thoroughly clean the exterior of the component. This action will prevent dirt from entering the internal mechanism.

1. Put an alignment mark across the sections of the final drive for assembly purposes. The parts must be reinstalled in the original locations.



Illustration 1

g00708089

2. Fasten the final drive to Tooling (A), as shown. The combined weight of the final drive and final drive sprocket is approximately 312 kg (688 lb).
3. Remove bolts (1) and the washers that hold the cover in position.

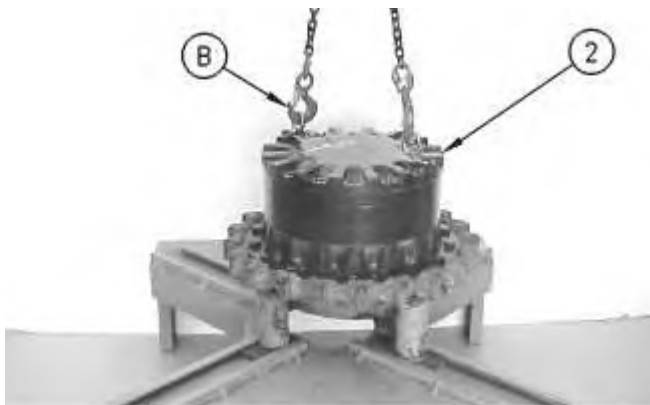

Illustration 2

g00708090

4. Remove the setscrews from cover (2), and fasten Tooling (B) and a suitable lifting device to cover (2), as shown. The weight of cover (2) is approximately 32 kg (70 lb). Remove cover (2).
-

<https://www.ebooklibonline.com>

Hello dear friend!

Thank you very much for reading.

Enter the link into your browser.

The full manual is available for immediate download.

<https://www.ebooklibonline.com>

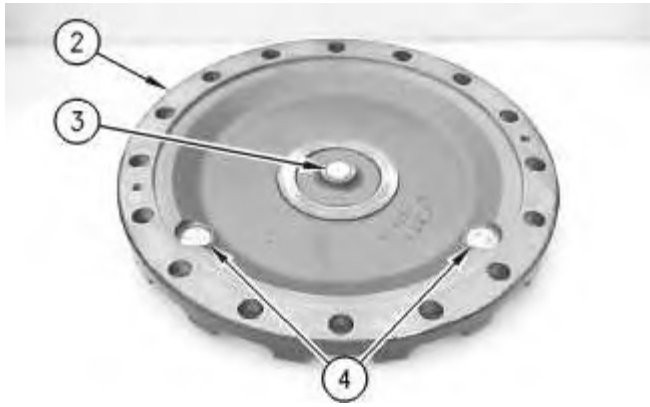

Illustration 3

g00708091

5. Remove thrust plate (3) from cover (2).
6. Remove plugs (4) from cover (2).

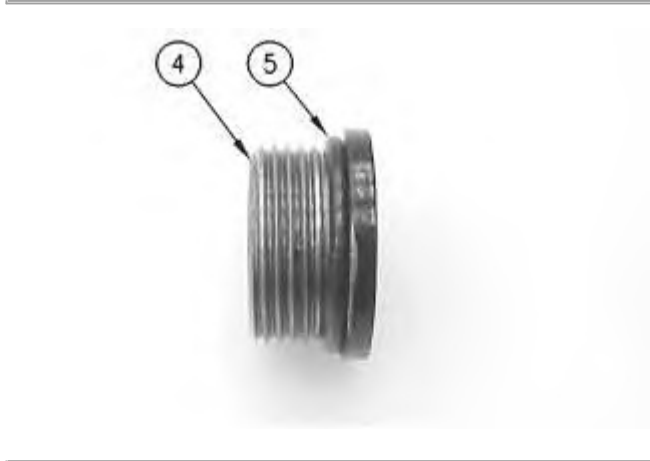

Illustration 4

g00708235

7. Remove O-ring seals (5) from both plugs (4) that were in the cover.

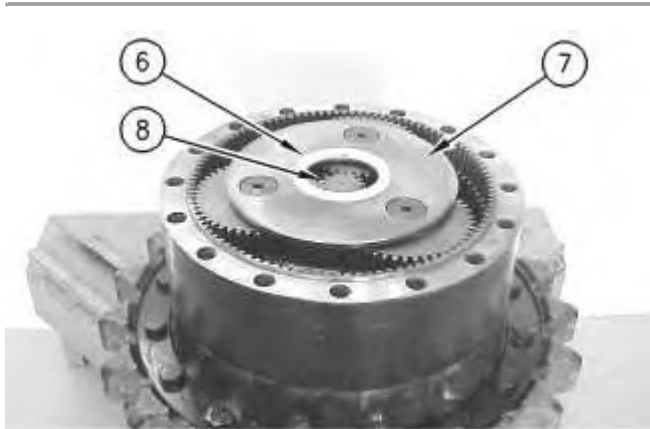

Illustration 5

g00708092

8. Remove spacer (6) from carrier assembly (7).
9. Remove sun gear (8) from carrier assembly (7).

10. Remove carrier assembly (7) by lifting the carrier assembly straight up. The weight of carrier assembly (7) is approximately 14 kg (30 lb).

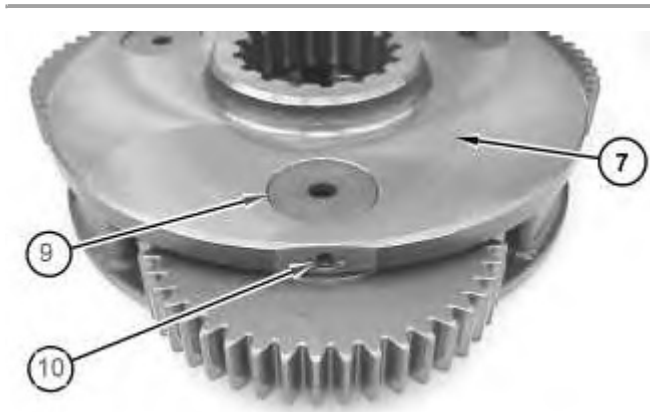

Illustration 6

g01304883

11. Disassemble carrier assembly (7), as follows.

- a. Drive spring pin (10) into planetary shaft (9) with a hammer and a punch.



Illustration 7

g00708144

- b. Remove planetary shaft (9) with spring pin (10) from the carrier assembly.
c. Remove spring pin (10) from planetary shaft (9) with a hammer and a punch.

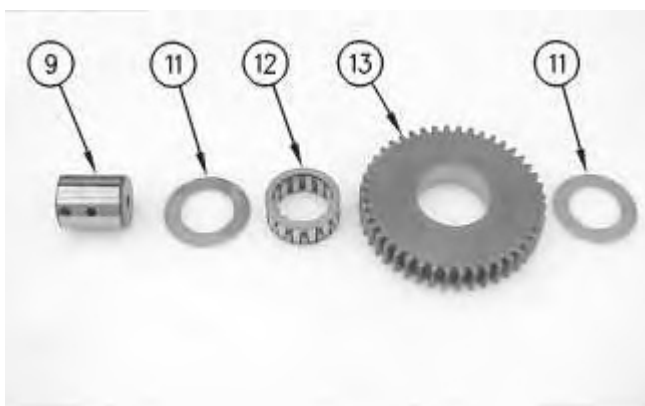

- d. Remove thrust washers (11) and planetary gear (13) from the carrier assembly.
 - e. Remove bearing (12) from planetary gear (13).
12. Repeat Steps 11.a through 11.e in order to remove the remaining planetary gears from the carrier assembly.



Illustration 9

g00708162

13. Remove sun gear (14) from carrier assembly (15).

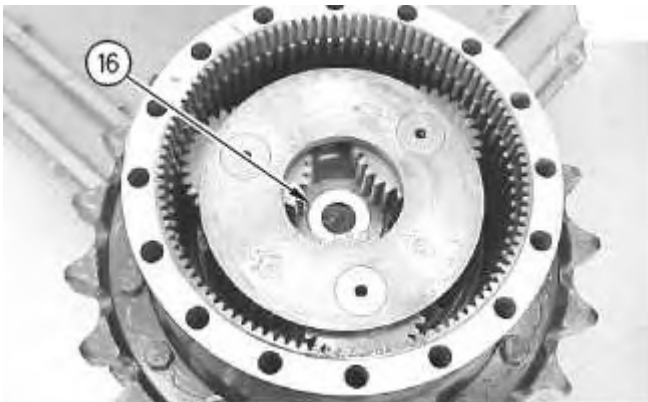

Illustration 10

g00708325

14. Remove spacer (16).
-

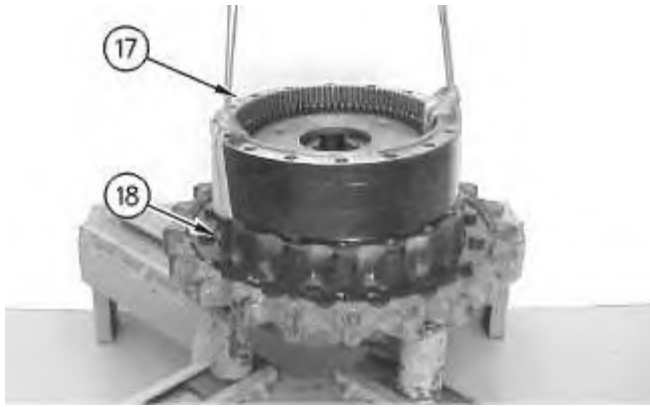

Illustration 11

g00708184

Note: It will be necessary to pry ring gears (17) away from main housing (18) in order to install the lifting slings.

15. Fasten a suitable lifting device to ring gears (17), as shown. Remove the ring gears from main housing (18). The weight of ring gears (17) is approximately 45 kg (100 lb).



Illustration 12

g00708360

16. Use a screwdriver or a chisel in order to separate two ring gears (17).

Note: Two ring gears (17) are held together with Tooling (F). It may be necessary to heat ring gears (17) in order to soften the sealant. Do not heat over 135 °C (275 °F) for more than thirty minutes.

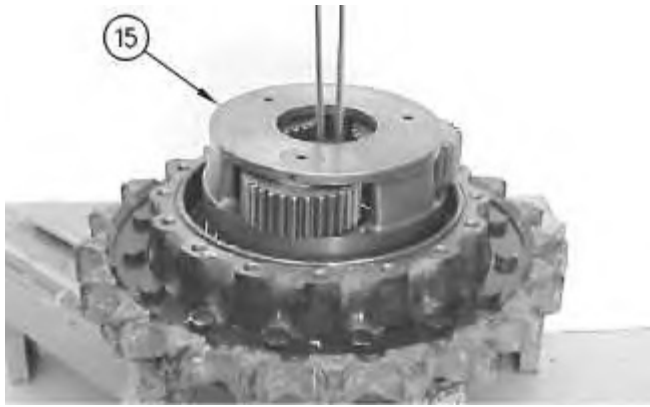

Illustration 13

g00708172

17. Position a 12.7 mm (0.50 inch) shackle under carrier assembly (15).
18. Fasten a suitable lifting device to the shackle.
19. Slowly lift carrier assembly (15) from the final drive. The weight of carrier assembly (15) is approximately 39 kg (85 lb).
20. Disassemble carrier assembly (15), as follows.



Illustration 14

g00708175

- a. Drive spring pin (20) into planetary shaft (19) with a hammer and a punch.



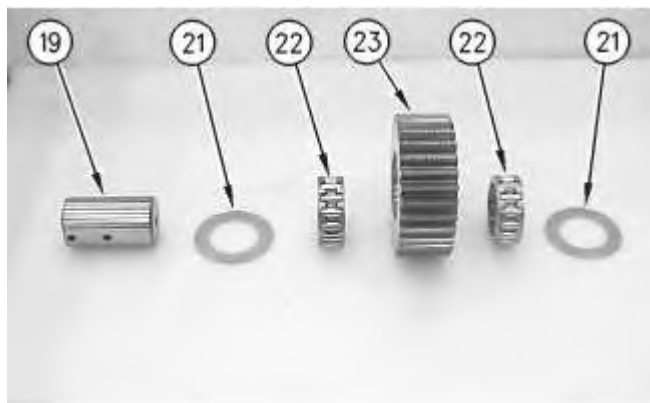

Illustration 16

- b. Remove planetary shaft (19) with spring pin (20) from the carrier assembly.
 - c. Remove spring pin (20) from planetary shaft (19) with a hammer and a punch.
 - d. Remove thrust washers (21) and planetary gear (23) from the carrier assembly.
 - e. Remove bearings (22) from planetary gear (23).
21. Repeat Steps 20.a through 20.e in order to remove the remaining planetary gears from the carrier.

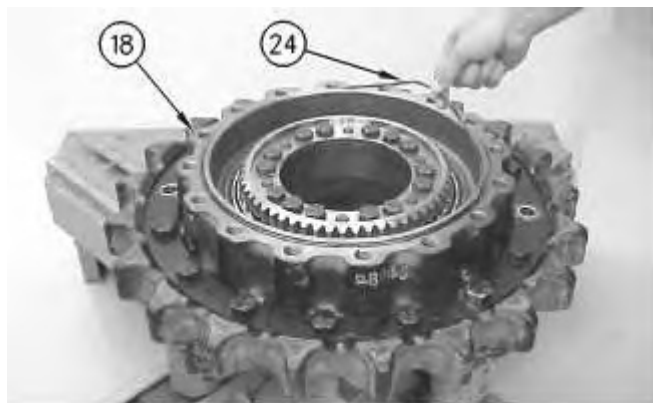

Illustration 17

22. Remove O-ring seal (24) from main housing (18).
-



Illustration 18

g00708187

23. Remove bolts (25) from gear (26).

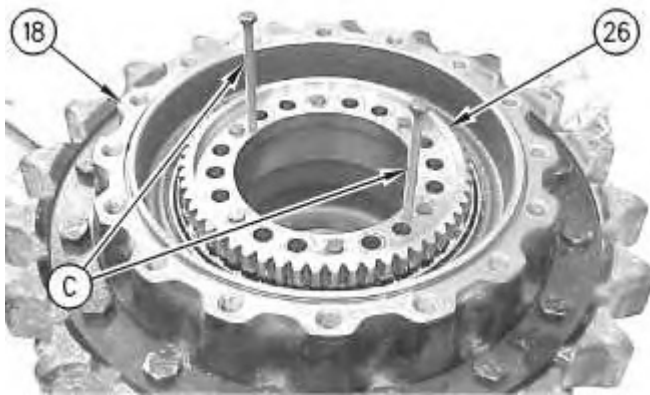

Illustration 19

g00708202

24. Use Tooling (C) in order to remove gear (26) from main housing (18).

Note: The motor housing will separate from main housing (18) once gear (26) is removed. Make sure that the motor housing is supported.



Illustration 20

g00708211

25. Remove shims (27) from the main housing.

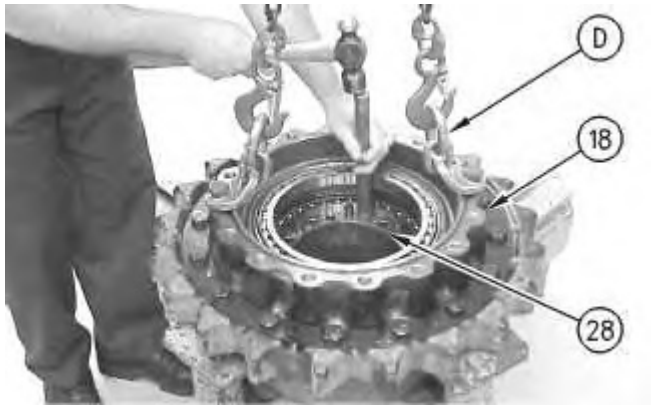

Illustration 21

g00708212

26. Fasten Tooling (D) and a suitable lifting device to main housing (18), as shown.
27. Use a hammer and a punch in order to separate main housing (18) and the final drive sprocket from motor housing (28). The combined weight of main housing (18) and the final drive sprocket is approximately 82 kg (180 lb).

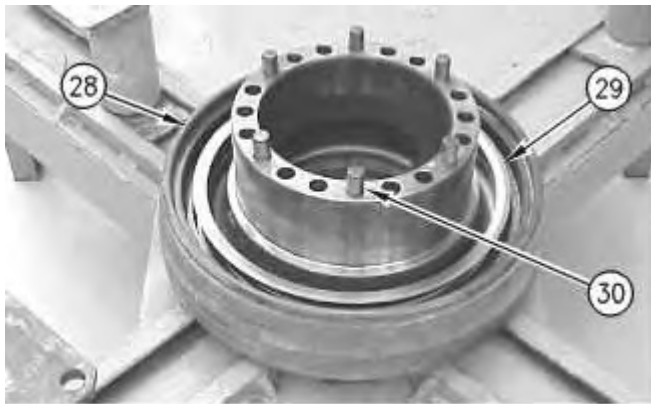

Illustration 22

g00708214

28. Remove Duo-Cone seal (29) from motor housing (28).
29. Remove alignment pins (30).

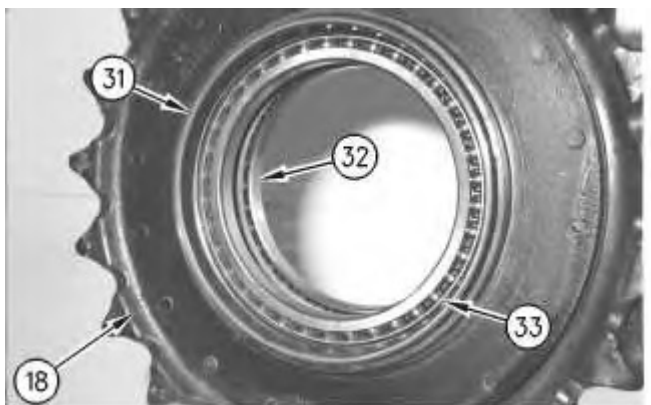

Illustration 23

g00708215

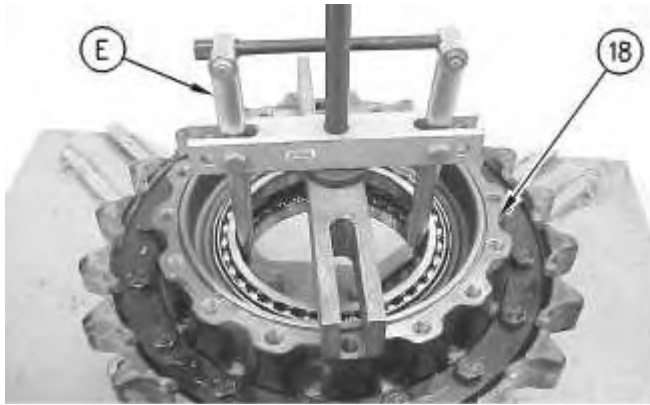

Illustration 24

30. Remove Duo-Cone seal (31) from main housing (18).
31. Use Tooling (E) in order to remove bearings (32) and (33) from the main housing.
32. If necessary, remove the final drive sprocket from the main housing.
33. Refer to Disassembly and Assembly, "Final Drive Sprocket - Remove and Install".

[Previous Screen](#)

Product: EXCAVATOR

Model: 315D L EXCAVATOR NCM

Configuration: 315D L Excavator NCM00001-UP (MACHINE) POWERED BY C4.2 Engine

Disassembly and Assembly 315D, 318D and 319D Excavators Machine Systems

Media Number -KENR5272-13

Publication Date -01/09/2017

Date Updated -06/09/2017

i05453369

Final Drive - Assemble

SMCS - 4050-016

Assembly Procedure

Table 1

Required Tools			
Tool	Part Number	Part Description	Qty
A	1P-2420	Transmission Repair Stand	1
B	439-3938	Link Bracket	2
D	439-3940	Link Bracket	2
G	126-3994	Duo-Cone Seal Installer	1
H	-	Loctite C5-A Anti-Seize Lubricant	
F	-	Loctite High Flex From-In-Place Gasket	

Note: Cleanliness is an important factor. Before assembly, all parts should be cleaned in cleaning fluid. Allow the parts to air dry. Wiping cloths or rags should not be used to dry parts. Lint may be deposited on the parts which may cause later trouble. Inspect all parts. If any parts are worn or damaged, use new parts for replacement. All disassembly and all assembly procedures must be performed on a clean work surface and in a clean hydraulic area. Keep cleaned parts covered and protected at all times.

Note: O-rings, gaskets, and seals should always be replaced. A used O-ring may not have the same sealing properties as a new O-ring. Use **1U-6396** O-Ring Assembly Compound during the assembly procedure.

Note: Apply a light film of hydraulic oil to all components before assembly.

1. Install the final drive sprocket if the sprocket was removed from the main housing.

2. Refer to Disassembly and Assembly, "Final Drive Sprocket - Remove and Install".

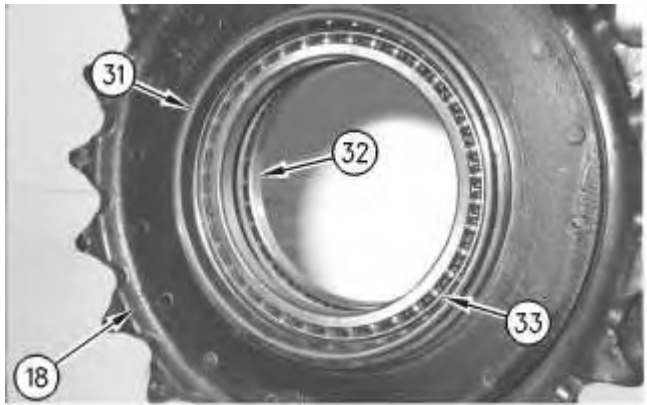

Illustration 1

g00708215

3. Apply Tooling (H) to the outer diameter of the bearings.
4. Install bearings (32) and (33) in main housing (18) with a suitable press.
5. Make sure that bearing (32) and bearing (33) contact the counter bore in the main housing.
6. Use the following procedure to preload the bearings and determine the correct thickness of shims.

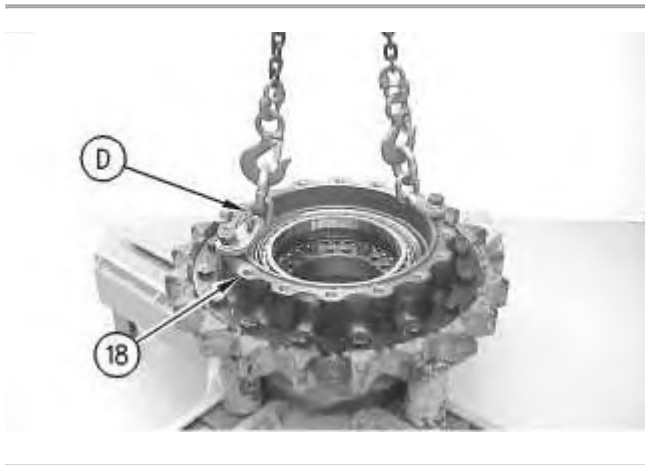

Illustration 2

g00713058

- a. Fasten Tooling (D) and a suitable lifting device to main housing (18). Install the main housing on the motor housing.
 - b. Put the main housing and the motor housing in a suitable press.
-

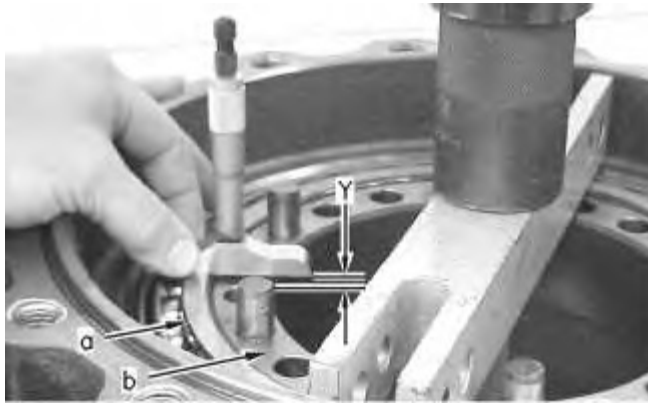

Illustration 3

g00709278

- (a) Bearing surface
- (b) Housing surface

- c. Use a suitable press and a spacer in order to apply a load of 4000 kg (8819 lb) on the bearings. Rotate the housing in order to seat the bearings.
- d. Reduce the load on the bearings to 1000 ± 100 kg (2205 ± 221 lb).
- e. Use a depth micrometer in order to measure the step length between the bearing surface and the housing surface. Take measurements at several different locations around the housing. Compute the average of the measured dimensions and record the number. Call this Dimension (Y).

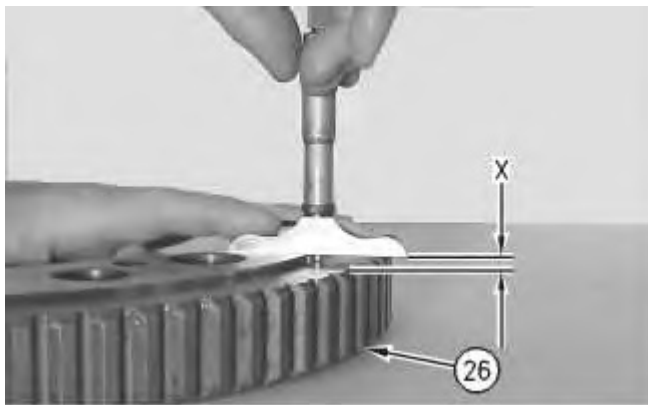

Illustration 4

g00709276

- f. Use a depth micrometer in order to measure the step length of gear (26). Take measurements at several different locations around the gear. Compute the average of the measured dimensions and record the number. Call this Dimension (X).
 - g. The thickness of the shims is equal to $(X - Y) \pm 0.05$ mm (0.002 inch).
- Note:** Use no more than two shims. If two shims are required, install the thinner shim next to the gear.
- h. Remove the main housing from the motor housing.

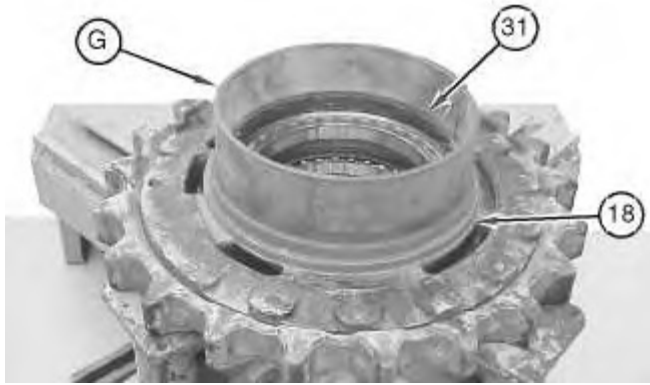

Illustration 5

g01021370

7. Use Tooling (G) in order to install Duo-Cone seal (31) in main housing (18). Refer to Disassembly and Assembly, "Duo-Cone Conventional Seals - Install".

Note: The rubber seals and all surfaces that contact the seals must be clean and dry. After installation of the seals, put clean SAE 30 oil on the contact surfaces of the metal seals.



Illustration 6

g01021371

8. Use Tooling (G) in order to install Duo-Cone seal (29) in motor housing (28).



Illustration 7

g00708214

9. Apply Tooling (H) to the surfaces that contact pins (30).

10. Install alignment pins (30).

Note: Do not damage the Duo-Cone seals in the main housing or in the motor housing during the assembly of the two components. After installation of the main housing on the motor housing, there will be a small gap between the components. The gap is caused by the Duo-Cone seals. This gap will be eliminated during installation of gear (26).

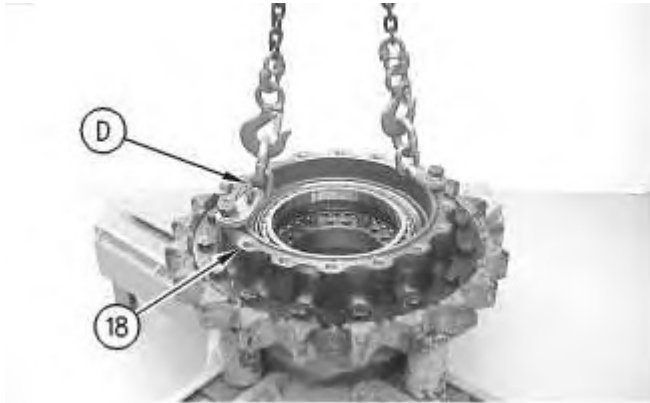

Illustration 8

g00713058

11. Fasten Tooling (D) and a suitable lifting device to main housing (18). Install the main housing on the motor housing.



Illustration 9

g00708211

12. Install shims (27) that were determined in Step 6.g in the main housing.

Note: If two shims are required, install the thinner shim next to the gear.



Illustration 10

g00708187

13. Install gear (26).
14. Install bolts (25) in gear (26). Install the bolts in an even pattern until the gear is seated against the bearing. Tighten bolts (25) in a crisscross pattern.

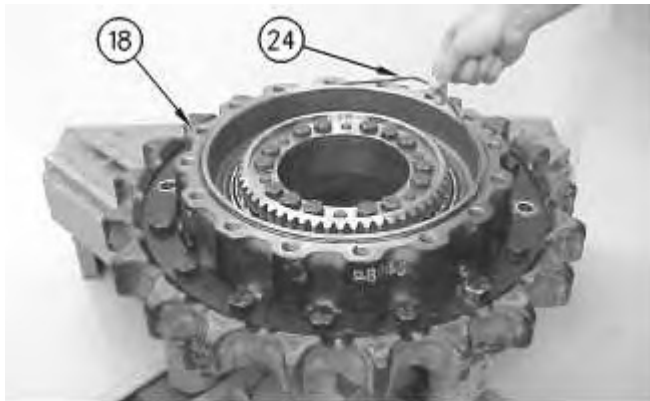

Illustration 11

g00708186

15. Install O-ring seal (24) to main housing (18).



Illustration 12

g00708175

16. Assemble carrier assembly (15), as follows.

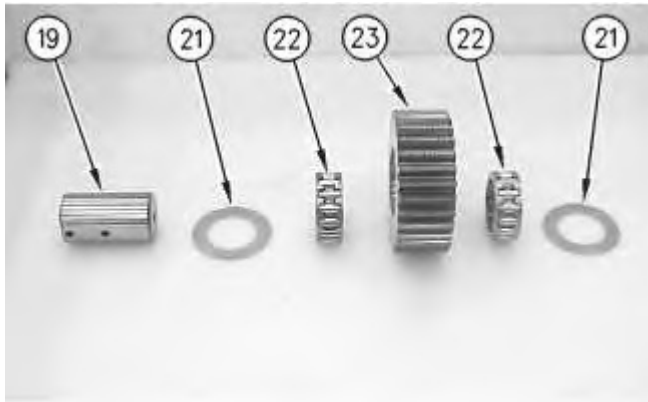

Illustration 13

g00708220

- a. Install bearings (22) in planetary gear (23).
- b. Install thrust washers (21) and planetary gear (23) in the carrier assembly.
- c. Use a deburring tool in order to remove the metal burr from the openings in the carrier. Install planetary shaft (19) in the carrier assembly.
- d. Drive spring pin (20) into planetary shaft (19) with a hammer and a punch.

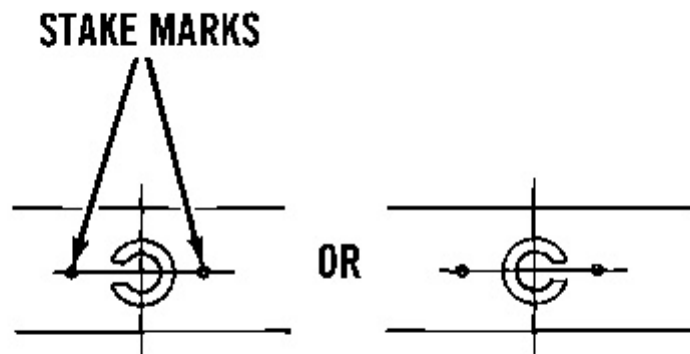

Illustration 14

g00513451

- e. Orient the split in spring pin (20) vertically to the carrier. Align the split in the spring pin to the top or to the bottom. Make a stake mark on each side of the spring pin hole in the carrier. Each stake mark should be approximately 1.50 mm (0.059 inch) from the outside diameter of the spring pin hole.
17. Repeat Steps 16.a through 16.e in order to install the remaining planetary gears in the carrier assembly.

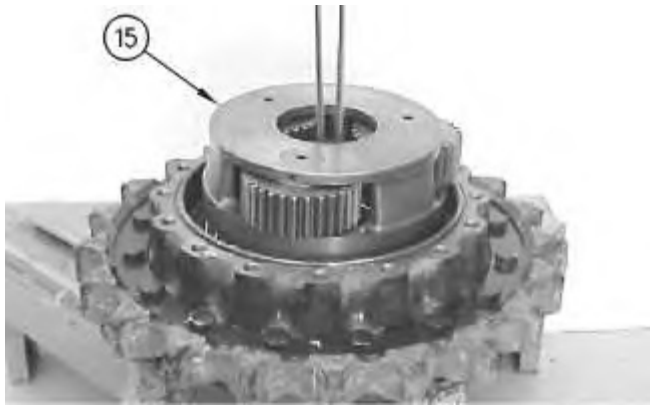

Illustration 15

g00708172

18. Install a lifting sling through the middle of carrier assembly (15). Fasten a 12.7 mm (0.50 inch) shackle to the suitable lifting device.
19. Install carrier assembly (15) on the final drive. The weight of carrier assembly (15) is approximately 39 kg (85 lb).
20. Remove the shackle and the suitable lifting device.



Illustration 16

g00713148

21. Apply Tooling (F) to the mating surface of ring gear (17b).
22. Install ring gear (17a) on ring gear (17b).

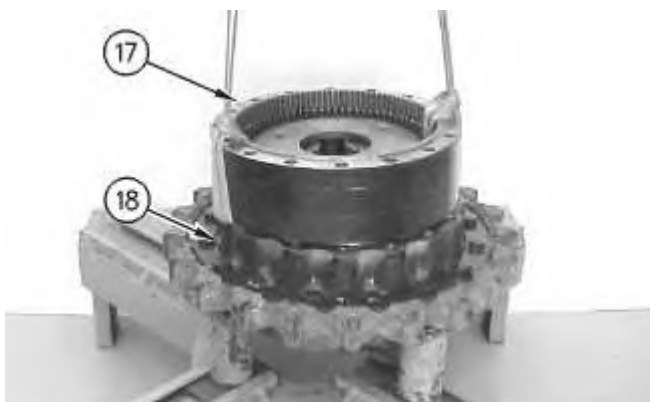

23. Fasten a suitable lifting device to ring gears (17), as shown. Install the ring gears to main housing (18). The weight of ring gears (17) is approximately 45 kg (100 lb).
-

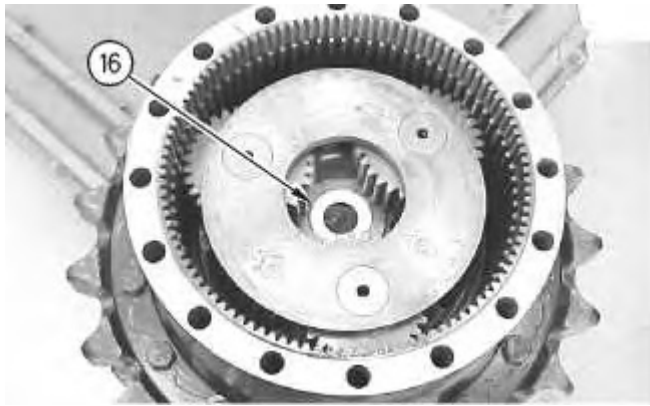

Illustration 18

24. Install spacer (16) in the carrier assembly.
-



Illustration 19

25. Install sun gear (14) in carrier assembly (15).
-

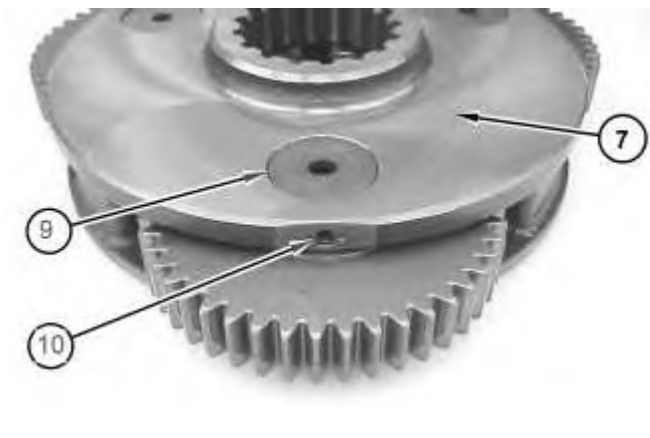

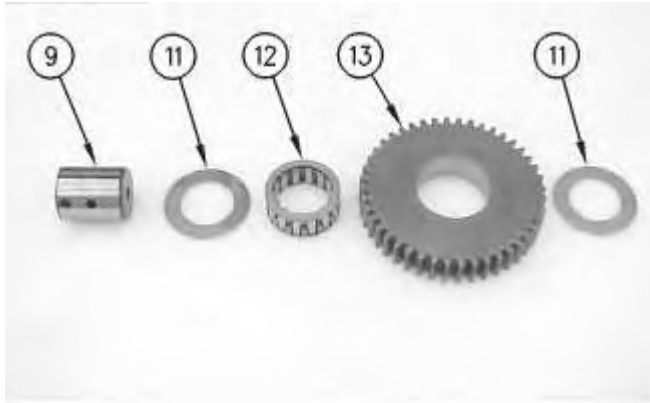

Illustration 21

26. Assemble carrier assembly (7), as follows.

- a. Install bearing (12) in planetary gear (13).
- b. Install thrust washers (11) and planetary gear (13) in the carrier assembly.
- c. Install planetary shaft (9) in the carrier assembly.
- d. Drive spring pin (10) into planetary shaft (9) with a hammer and a punch.

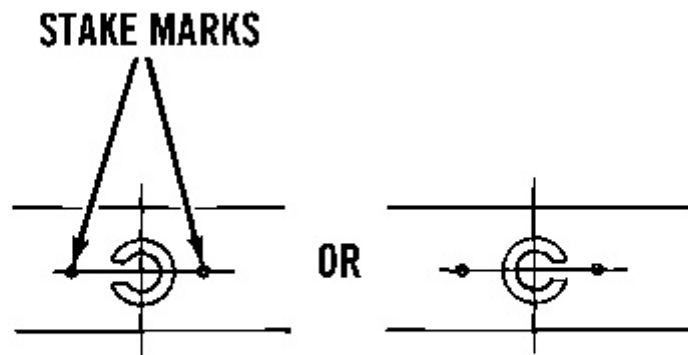

Illustration 22

- e. Orient the split in spring pin (10) vertically to the carrier. Align the split in the spring pin to the top or to the bottom. Make a stake mark on each side of the spring pin hole in the carrier. Each stake mark should be approximately 1.50 mm (0.059 inch) from the outside diameter of the spring pin hole.

27. Repeat Steps 26.a through 26.e in order to install the remaining planetary gears in the carrier assembly.

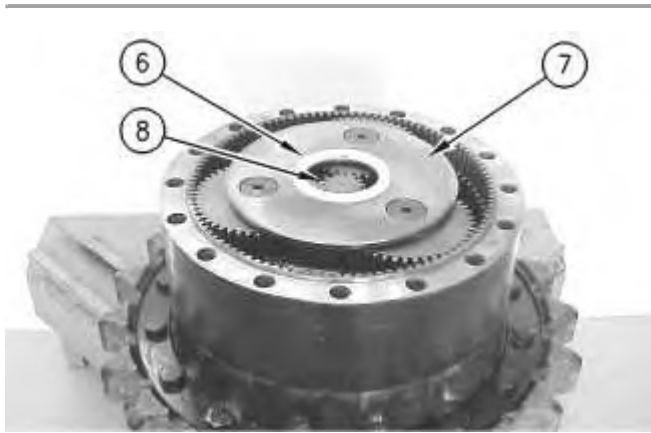

Illustration 23

g00708092

28. Install carrier assembly (7) in the ring gear. The weight of carrier assembly (7) is approximately 14 kg (30 lb).
29. Install sun gear (8) in carrier assembly (7).
30. Install spacer (6) in carrier assembly (7).

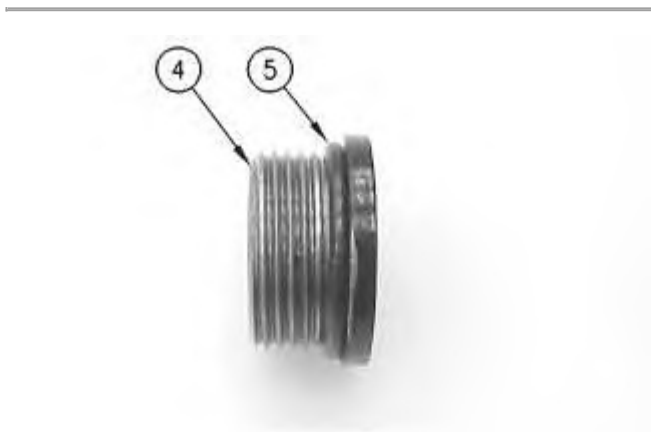
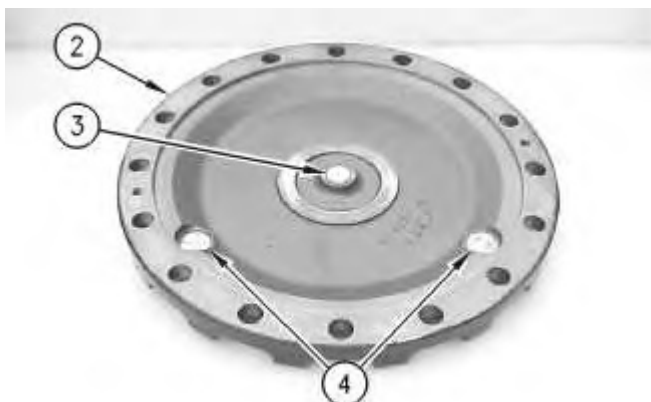

Illustration 24

g00708235

31. Install new O-ring seals (5) on plugs (4) that were in the cover.





Suggest:

If the above button click is invalid.

Please download this document

first, and then click the above link

to download the complete manual.

Thank you so much for reading

32. Install plugs (4) in cover (2). Tighten plugs (4) to a torque of 80 ± 10 N·m (59 ± 7 lb ft).
33. Install thrust plate (3) in cover (2).
34. Apply Tooling (F) to the mating surface of the ring gear.

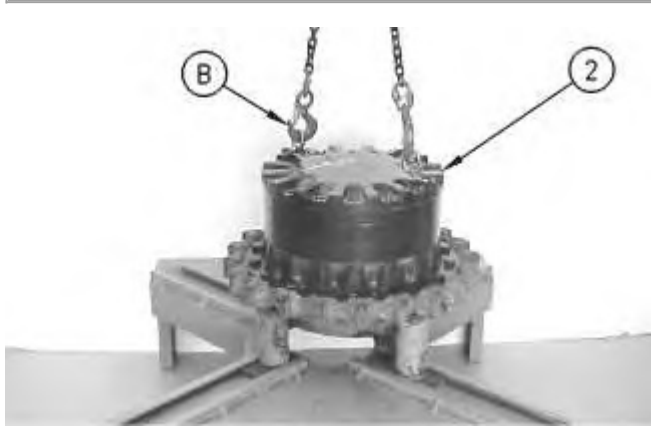

Illustration 26

g00708090

35. Fasten Tooling (B) and a suitable lifting device to cover (2), as shown. The weight of cover (2) is approximately 32 kg (70 lb). Install cover (2).
36. Remove Tooling (B) and install the setscrews in cover (2).



Illustration 27

g00708089

37. Install bolts (1) and the washers that hold the cover in position. Tighten bolts (1) in a crisscross pattern.
38. Remove the final drive from Tooling (A). The combined weight of the final drive and final drive sprocket is approximately 310 kg (683 lb).

End By:

- a. Install the final drive.
-

<https://www.ebooklibonline.com>

Hello dear friend!

Thank you very much for reading.

Enter the link into your browser.

The full manual is available for immediate download.

<https://www.ebooklibonline.com>